

漏液センサ LIQUID LEAK SENSORS

WL10

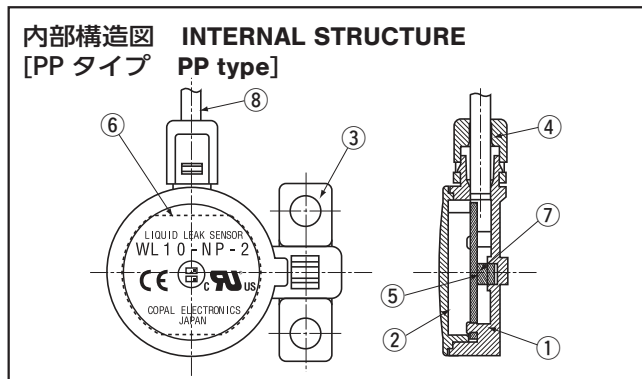
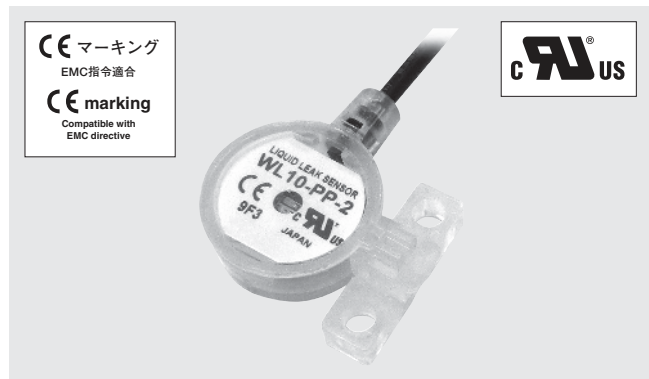

■特長 FEATURES

- 独自の光学技術により様々な分野で使用可能
- 遮光板と増幅回路がなくても漏洩検知可能
- PFA 材ハウジングにより、腐食性液漏れ検知も可能
- 小型、薄型 (φ 25 mm、t = 10 mm)
- 鉛フリー対応、UL / CE マーキング対応
- Operable in various area thanks to unique optical technology
- Can detect leakage without a douser and additional amplifying circuit
- PFA casing available for detecting leakage of corrosive liquid
- Compact and Slim size (φ 25 mm, t = 10 mm)
- Lead-free Soldering, UL standard, CE Marking

名称 Part name	材料 Material
① 本体ケース Housing	PP
② フタ Cover	
③ 取付具 Mounting plate	
④ 締付具 Sealing cap	
⑤ 基板 P.C. board	グラスエポキシ Glass-Epoxy
⑥ ラベル Label	ポリエステルフィルム Polyester film
⑦ フォトインタラプタ Photo-interrupter	-
⑧ ケーブル Cable	PVC

■型式表示 MODEL NUMBER DESIGNATION

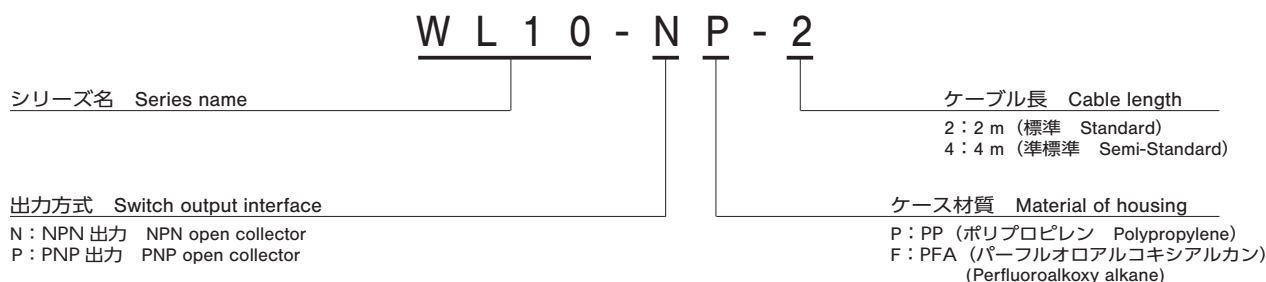

■型式一覧表 LIST OF MODEL NUMBERS

出力方式 Switch output interface		型式 Model number			
		NPN		PNP	
ケース材質 Material of housing		PP	PFA	PP	PFA
ケーブル長 Cable length	2 m	WL10-NP-2	WL10-NF-2	WL10-PP-2	WL10-PF-2
	4 m	Ⓢ WL10-NP-4	Ⓢ WL10-NF-4	Ⓢ WL10-PP-4	Ⓢ WL10-PF-4

※ご注文に際しては、上記型式をご確認ください。
Verify the above model numbers when placing orders.

Ⓢ 印の型式は受注生産となります。
The products marked Ⓢ are manufactured upon receipt of order basis.

WL10

LIQUID LEAK SENSORS

標準仕様 STANDARD SPECIFICATIONS

- 特記ない場合、周囲温度 25 ± 5 °C、駆動電圧 24 V DC で規定します。
Unless otherwise specified, the specs are defined at an ambient temperature of 25 ± 5 °C and excitation voltage of 24 V DC.

項目 Item		型式 Model number	WL10	
			NPN	PNP
一般仕様 General specifications	使用温度 Operating temp. range	°C	- 10 ~ 60	
	使用湿度 Operating humidity	%RH	35 ~ 85 (結露ないこと No condensation)	
	保存温度 Storage temp.	°C	- 20 ~ 70 (大気圧、65 %RH 以下 Atmospheric pressure, humidity 65 %RH maximum)	
	適用媒体 Pressure medium		水 (PP) / PFA を腐食させない液体 Water (PP) / Corrosive fluids compatible with PFA	
	ケース材質 Material of housing		PP/PFA	
	質量 Net weight	g	Approx. 30 (WL10- * P-2)	Approx. 50 (WL10- * P-4, WL10- * F-2)
電源 Power	駆動電圧 Supply voltage	V DC	12 ~ 24 \pm 10 %	
	消費電流 Consumption current	mA maximum	10 (Except open collector output)	
出力仕様 Output	スイッチ容量 Switching capacity		シンク電流 : 50 mA 以下 耐電圧 : 30 VDC (過電流保護回路あり) Voltage endurance : 30 VDC Sink current : 50 mA maximum (Over current protection)	ソース電流 : 50 mA 以下 耐電圧 : 24 VDC (過電流保護回路あり) Voltage endurance : 24 VDC Sourced current : 50 mA maximum (Over current protection)
	残量電圧 Residual voltage	V maximum	1.0 V 以下 1.0 V maximum	2.0 V 以下 2.0 V maximum
	動作 Operation grade		正常時 : 出力 ON、緑色 LED 点灯 漏液検出時 : 出力 OFF、赤色 LED 点灯 Normal condition : Switch output is ON / Green LED is ON Leakage detection : Switch output is OFF / Red LED is ON	

環境特性 ENVIRONMENTAL CHARACTERISTICS

試験項目 Test item	試験方法 Test conditions	規格 Specification
振動 Vibration	10 ~ 500 Hz, 1.5 mm maximum / 98.1 m / S ² , 3 directions for 2 hours each	標準仕様内容を満足する Meets standard specifications
衝撃 Shock	490 m/s ² , 3 directions for 3 times each	
保護構造 Protection grade	IP67	
EMC	EMI : EN55011: 2007, A2 : 2007 Group 1, class B EMS : EN61326-1: 2006 Table 2	

内部電気回路 INTERNAL ELECTRICAL SCHEMATICS

● NPN

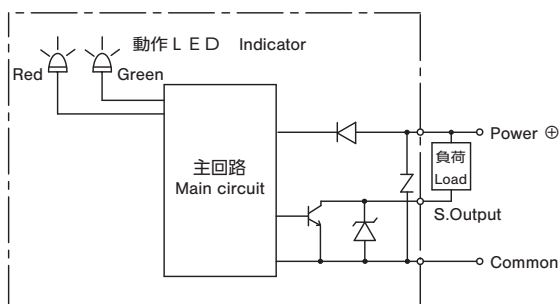

● PNP

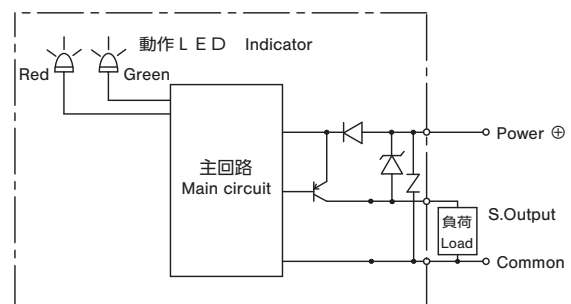

WL10

LIQUID LEAK SENSORS

外形寸法図 OUTLINE DIMENSION

Unless otherwise specified, tolerance: ± 0.5 (Unit: mm)

● ケース素材 PP タイプ Material of housing - PP

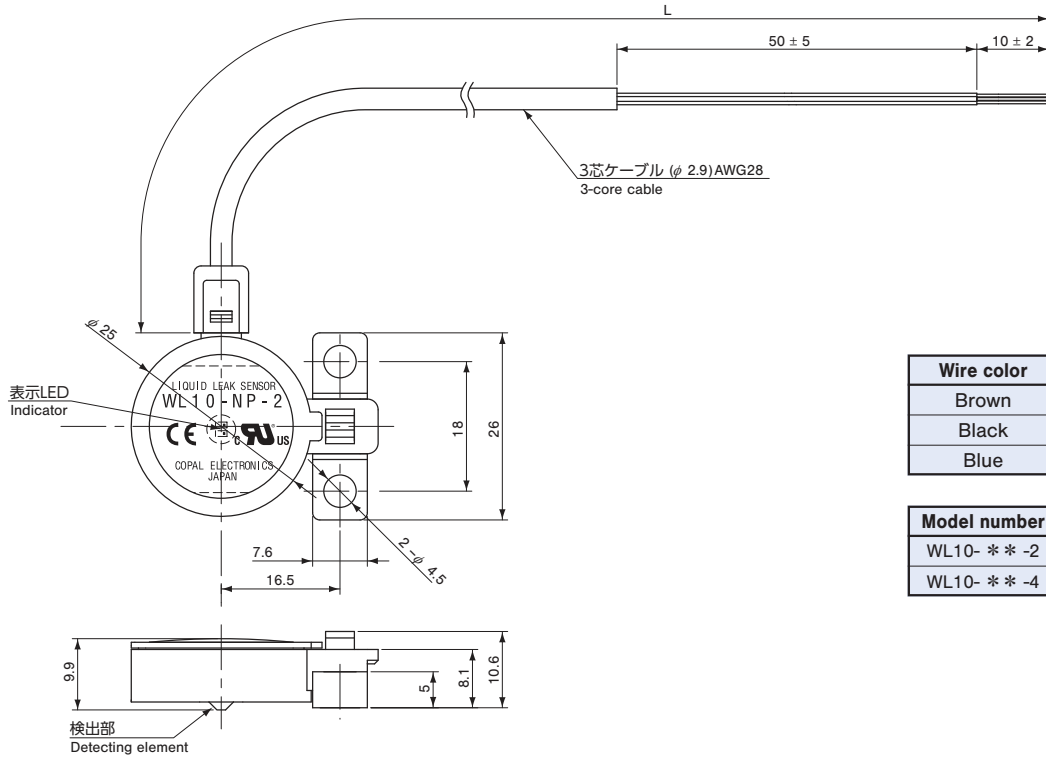

Wire color	Connection
Brown	Power ⊕
Black	Output
Blue	Common

Model number	Cable length
WL10-**-2	2000 ± 100 mm
WL10-**-4	4000 ± 200 mm

● ケース素材 PFA タイプ Material of housing - PFA

