

P.C.B. HOLE DRILLINGS
(P.C.B. TOP SIDE)

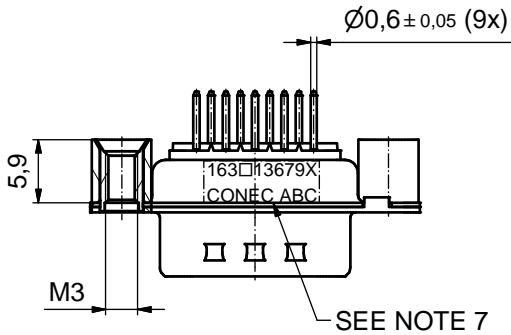

(5:1)

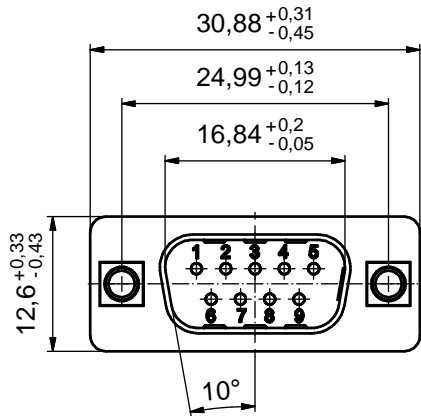
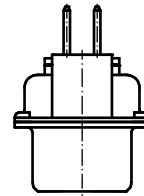
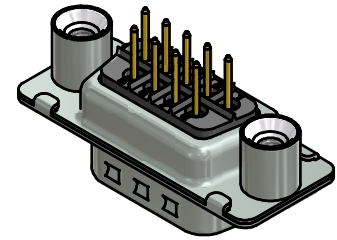
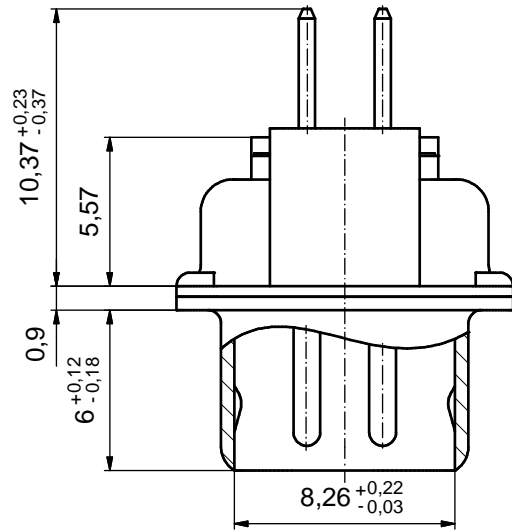

NOTES:

- METALSHELLS: STEEL; min. 315µm TIN over 40-80µm NICKEL
- INSULATORS: PBT GF UL 94 V-0; BLACK
- CONTACTS: COPPER ALLOY; PLATING (SEE PART NO.):
 - PLEASE ADD A for GOLD FLASH over NICKEL (PREFERRED TYPE)
 - PLEASE ADD B for 20µm HARD GOLD over min. 50µm NICKEL
 - PLEASE ADD C for 30µm HARD GOLD over min. 50µm NICKEL
- THREADED REAR SPACERS: COPPER ALLOY; min. 200µm TIN over 80µm NICKEL
- SLEEVES: COPPER ALLOY; min. 200µm TIN over 80µm NICKEL
- MAXIMUM TORQUE VALUE FOR THREAD: 6 in.LB
- CONNECTOR IS PART MARKED: 163□13679X CONEC ABC (see note 3)

RoHS compliant

THIS DRAWING MAY NOT BE COPIED OR REPRODUCED IN ANY WAY, AND MAY NOT BE PASSED ON TO A THIRD PARTY WITHOUT WRITTEN PERMISSION. OWNERSHIP AND COPYRIGHT OF CONEC GmbH DO NOT ALTER CAD DRAWING BY HAND				tolerance		scale: 2:1 (5:1)
				date	name	material: SEE NOTES
				drawn	28.04.2015	Heinrich
				appd.	28.04.2015	Henneboel
				norm		
				d-old		
				a	Original	
rev.	description	date	name			title: D-SUB MALE 9pos. SOLDER PIN STRAIGHT with threaded rear spacer
						dwg no: 16K1A3650
						part no: 163□13679X (see note 3)