

PRODUCT DATA DRAWING

REVISION HISTORY			
REV	DESCRIPTION	DATE	APPROVED
-	DCN 43089	02/17	MAL

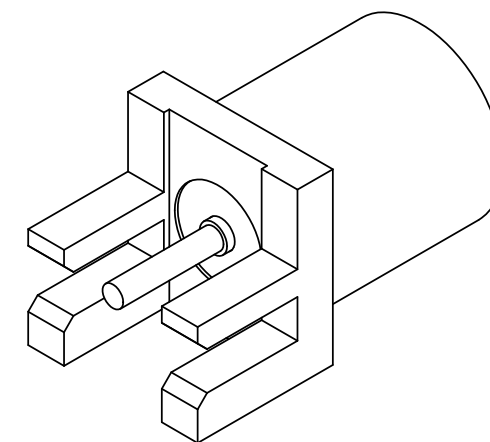
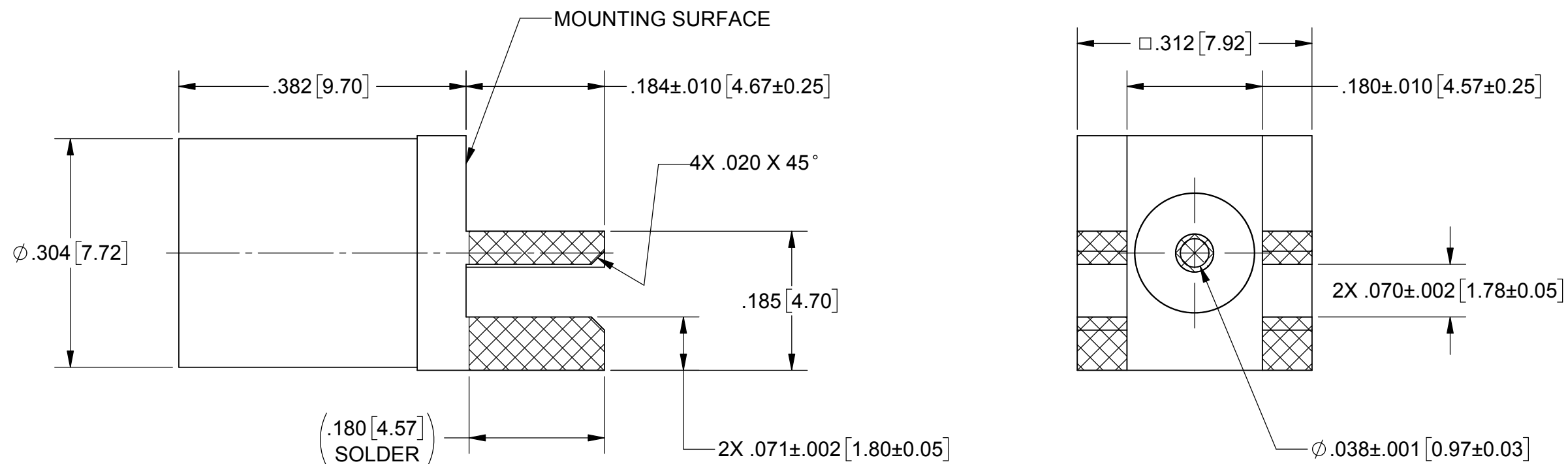

MATERIAL:

BODY: BRASS PER ASTM B16, ALLOY UNS No. C36000

CONTACT & CONTACT SLEEVE: BERYLLIUM COPPER PER ASTM B196, ALLOY No. UNS C17300, TD04

INSULATOR: PTFE PER ASTM D1710, TYPE I, GRADE 1, CLASS B

FINISH:
BODY, CONTACT & CONTACT SLEEVE: GOLD PER ASTM B488, TYPE II, CODE C, CLASS 1.27 OVER NICKEL PER AMS-QQ-N-290, CLASS 1, .00005" MIN.

NOTES:

1. FOR RECOMMENDED FOOTPRINT TO YOUR SPECIFIC PCB, CONTACT SV MICROWAVE SALES DEPARTMENT (sales@svmicro.com, 561-840-1800)
2. TO BE TIN DIPPED USING Sn96 SOLDER
3. ALL DIMENSIONS APPLY PRIOR TO SOLDER DIPPING

PERFORMANCE:

IMPEDANCE: 50 OHMS
FREQ. RANGE: DC TO 22.0 GHz
DWV: 1000 VRMS

MATERIAL: SEE NOTES	DIMENSIONS ARE IN INCHES TOLERANCES: FRACTIONAL: $\pm 1/64$ ANGULAR: X° $\pm 1'0''$ X'X' $\pm 15''$	UNLESS OTHERWISE SPECIFIED 1) ALL DIMENSIONS ARE IN INCHES (MILLIMETERS) 2) ALL DIMENSIONS ARE AFTER PLATING. 3) BREAK CORNERS & EDGES .005 R. MAX. 4) CHAM. 1ST & LAST THREADS. 5) SURFACE ROUGHNESS 63-MIL-STD-10. 6) DIA. 'S ON COMMON CENTERS TO BE CONCENTRIC WITHIN .005 T.I.R. 7) REMOVE ALL BURRS	SV Microwave, Inc. 2400 Centrepark West Drive, Suite 100 West Palm Beach, FL 33409
FINISH: SEE NOTES	DECIMAL: X $\pm .030$.XX $\pm .010$.XXX $\pm .005$	INTERPRET DIMENSIONS AND TOLERANCES PER ASME Y14.5M - 1994	TITLE: BMA JACK END LAUNCH
SURFACE AREA: N/A	THIRD ANGLE PROJECTION	DRAWN: VB 02/03/17	SIZE: B CAGE CODE: 95077 DWG. NO. 1785-0003-TD
PROPRIETARY THE INFORMATION CONTAINED IN THIS DRAWING IS THE SOLE PROPERTY OF SV MICROWAVE, INC. ANY REPRODUCTION IN PART OR AS A WHOLE WITHOUT THE WRITTEN PERMISSION OF SV MICROWAVE, INC IS PROHIBITED.		CHECKED: MAL 02/04/17	SCALE: 6:1
		APPROVED: MAL 02/04/17	SHEET 1 OF 1