

THIS DRAWING IS UNPUBLISHED. RELEASED FOR PUBLICATION  
 © COPYRIGHT BY TYCO ELECTRONICS CORPORATION. ALL RIGHTS RESERVED.

LOC	DIST	REVISIONS			
P	LTR	DESCRIPTION	DATE	DWN	APVD
AF	50	B1	ECR-06-023927(REDRAWN IN AUTOCAD)	10NOV06	HMR GP

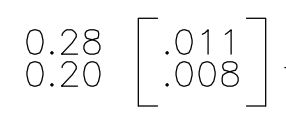
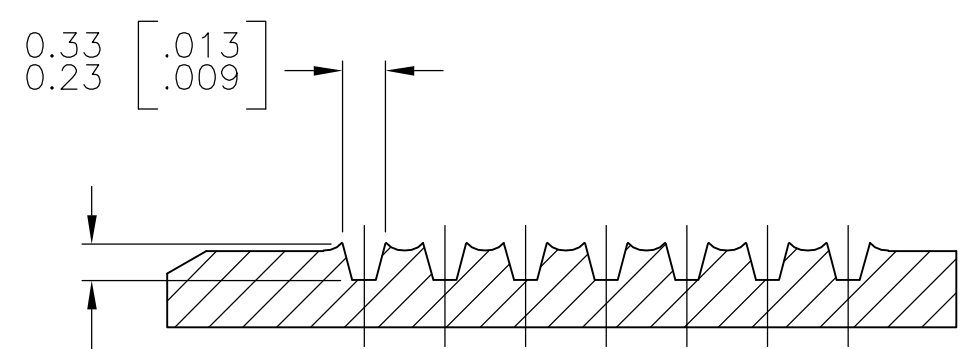
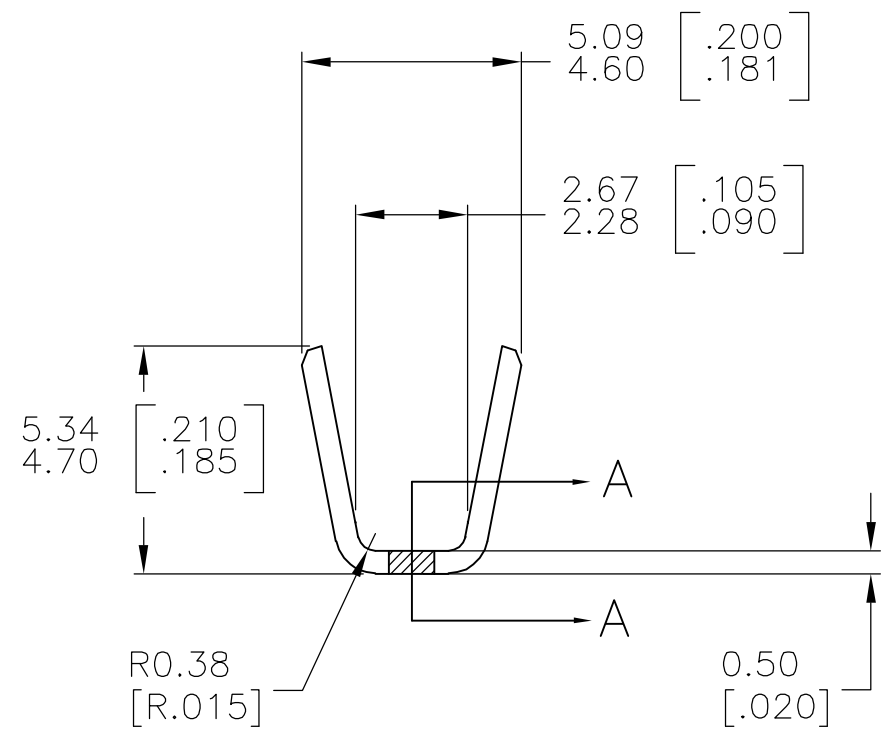
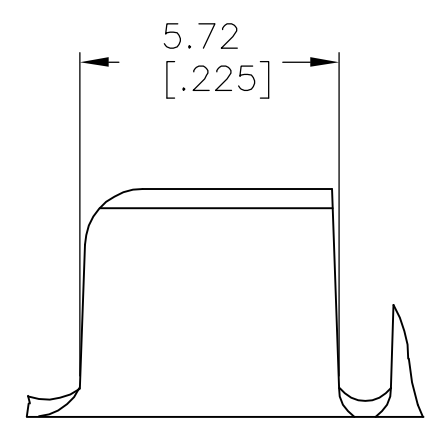
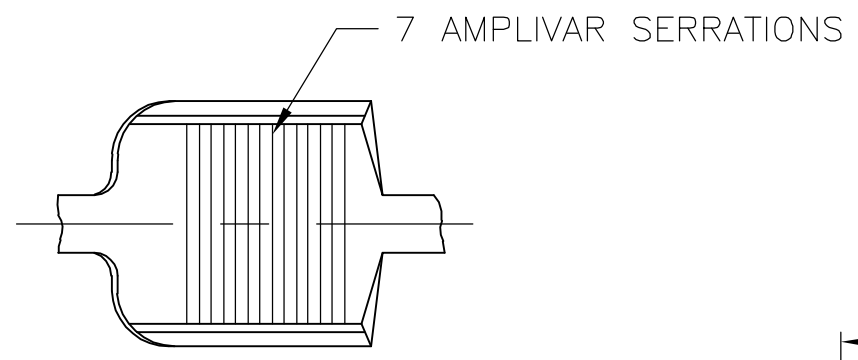

SECTION A-A  
SCALE 20:1

- 1 CONTINUOUS STRIP ON REELS.
- 2 DIMENSIONS IN BRACKETS ARE IN INCHES.
- 3 WIRE RANGE: 3000-7000 CMA.

TIN	62201-2
NONE	62201-1
FINISH	PART NO

THIS DRAWING IS A CONTROLLED DOCUMENT.		DWN RAGHAVENDRA 10NOV06	Tyco Electronics Corporation Harrisburg, PA 17105-3608	
DIMENSIONS: mm [INCHES]		CHK G.D.PORTA		
TOLERANCES UNLESS OTHERWISE SPECIFIED:		APVD G.D.PORTA	NAME	
0 PLC ± - 1 PLC ± - 2 PLC ± - 3 PLC ± 0.38 [.015] 4 PLC ± - ANGLES ± 1° 0'		PRODUCT SPEC	SPLICE, AMPLIVAR 7 SERRATIONS	
MATERIAL BRASS		FINISH SEE TABLE	APPLICATION SPEC	RESTRICTED TO
		WEIGHT -	SIZE A3	CAGE CODE 00779
			DRAWING NO C-62201	REV B1
CUSTOMER DRAWING			SCALE 6:1	SHEET 1 OF 1