

PRODUCT NUMBER
SEE TABLE

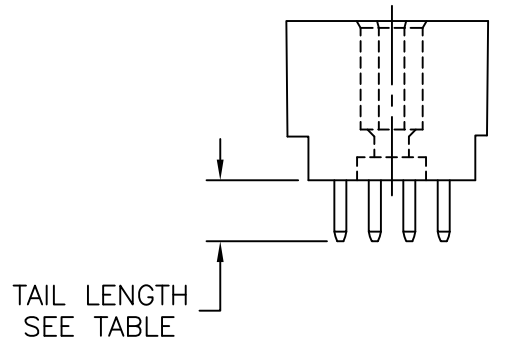

mat'l. code NOTE 4		surface ISO 1302 ✓		tolerance ISO 406 ISO 1101		projection INCH/MM		product family HPC	
ltr	ecn no	dr	date	tolerances unless otherwise specified		Amphenol FCi		title	
T	ELX-I-27215	MJA	06/13/17	angles	linear			4 ROW VERTICAL HEADER W/SOLDER TAIL PINS, 0 G.P.	
M	v00272	JWS	2/1/00	0°±2'	.xxx±.005/.13	scale 1:1		dwg no	
N	v05-0475	DAI	7/20/05	dr	D.INGRAM	7/20/05	sheet 1 of 4		size
P	v05-0723	HTB	7/20/05	enr	D.HORCHLER	7/20/05	50015		A3
R	v05-1039	DAI	11/11/05	chr	M JACOB	06/13/17	Product Customer Drawing		
S	M06-0283	MHT	7/27/06	appd	BIJU K PAUL	06/13/17			
sheet	revision	T	S	S	T				
index	sheet	1	2	3	4				

PRODUCT NUMBER
SEE TABLE

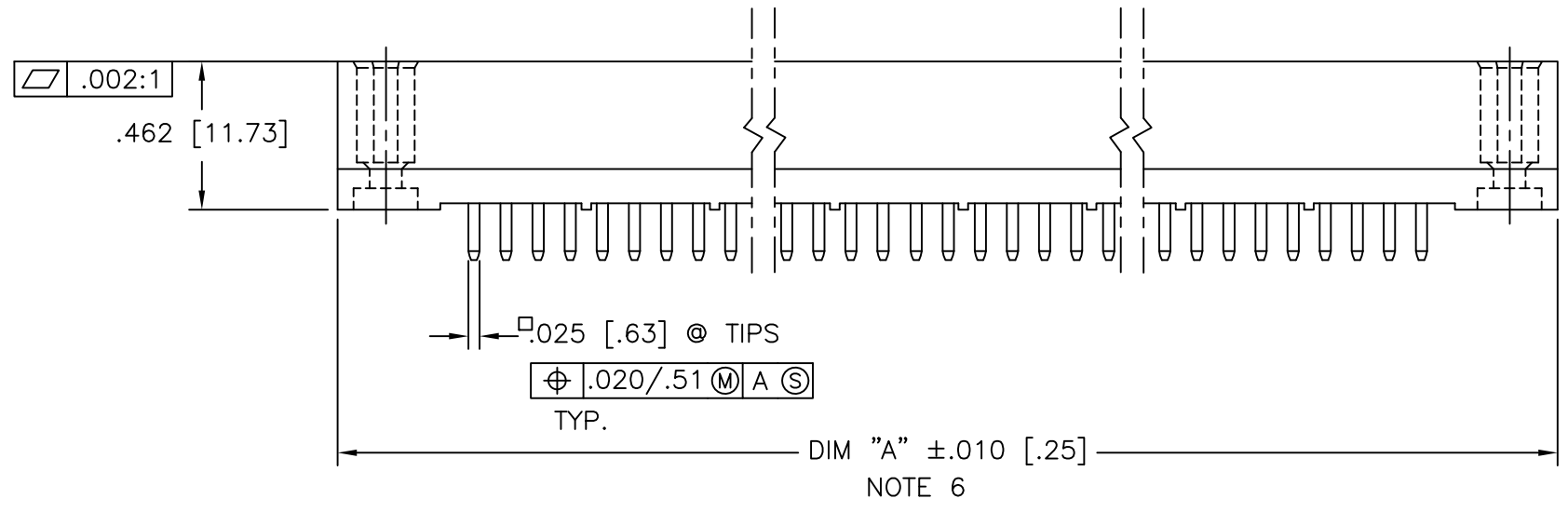
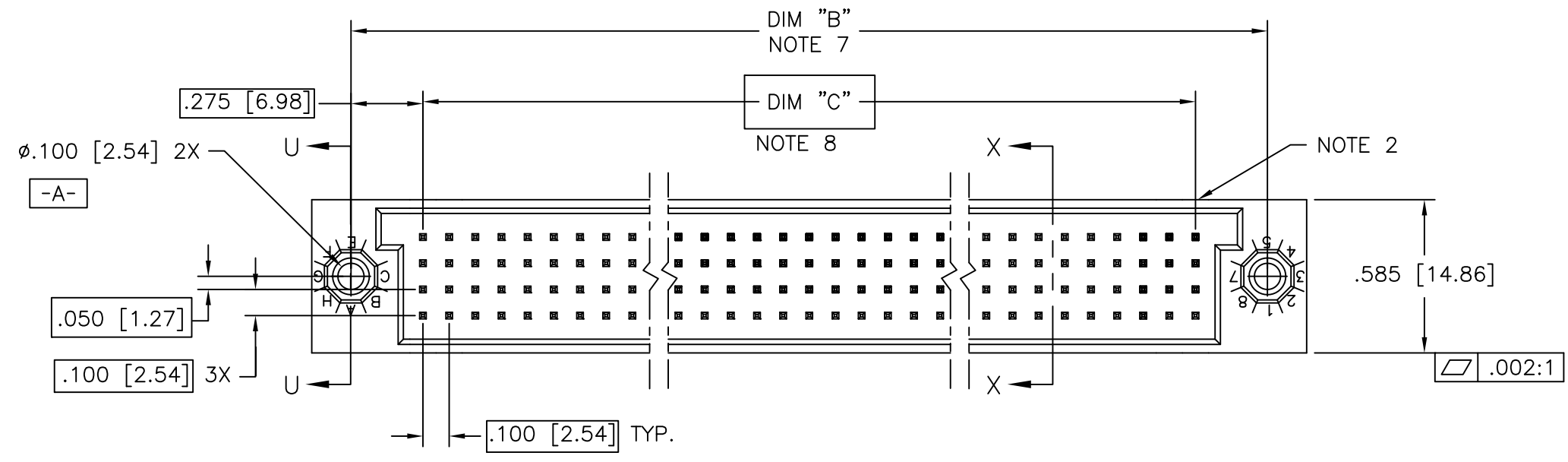
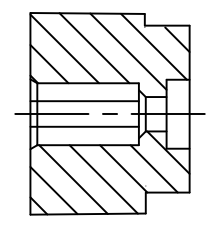

SECTION U-U

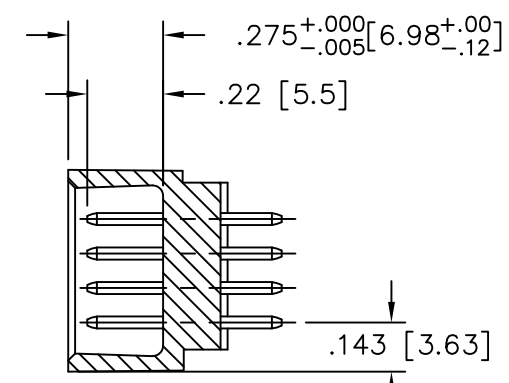

SECTION X-X

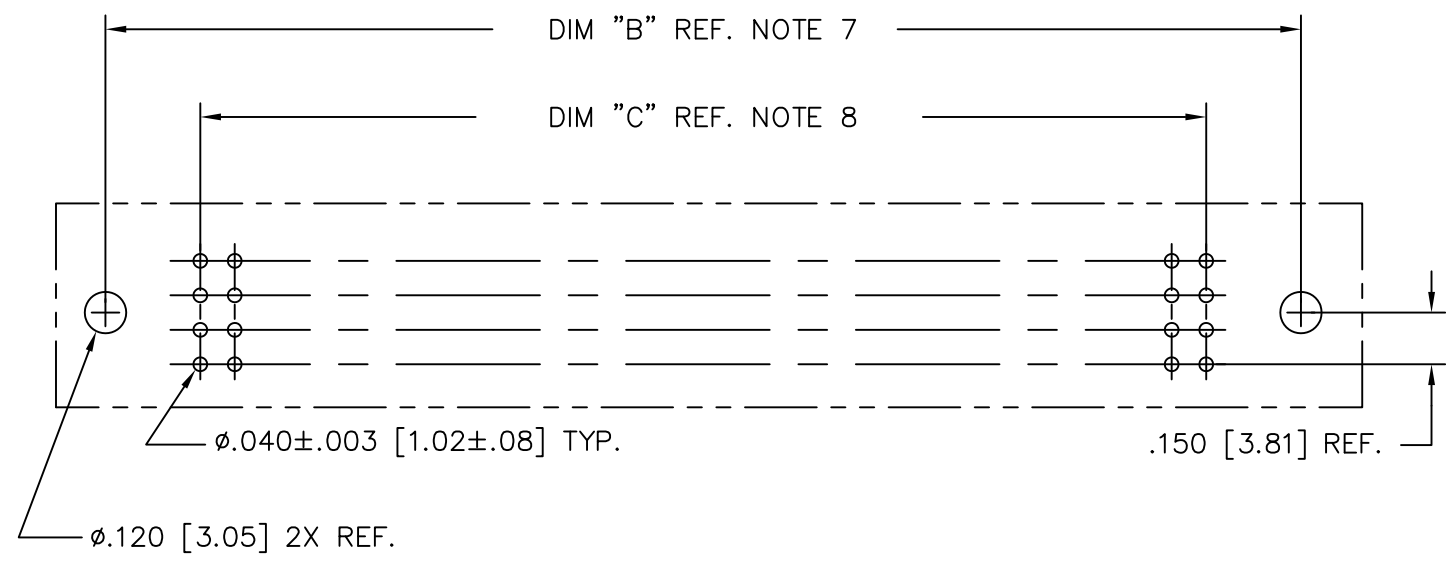

RECOMMENDED PCB LAYOUT
(ALL HOLES LOCATED ON .100/2.54 GRID
UNLESS OTHERWISE SPECIFIED)

mat'l. code NOTE 4		surface ISO 1302 ✓	tolerance ISO 406 ISO 1101	projection 	product family HPC
ltr	ecn no	dr	date	tolerances unless otherwise specified	title 4 ROW VERTICAL HEADER W/SOLDER TAIL PINS, 0 G.P.
S				angles linear 0°±2°	
				.xx±.01/.3	INCH/MM
				.xxx±.005/.13	scale 1:1
				.xxx±.0020/.05	
dr	D.INGRAM	7/20/05			dwg no
enr	D.HORCHLER	7/20/05			sheet 2 of 4
chr	T.BREWBAKER	7/20/05			size
appd	D.HORCHLER	7/20/05			50015
					A3
sheet index	revision sheet				type
					Product Customer Drawing

PRODUCT NUMBER
SEE TABLE

50015-XX022 AND 50015-XX022LF ONLY

	1	5	10	15	20	25	30	32
D			B		B	B		
C			B		B	C		
B	B		C		B	B		
A	B		C		B	C		

PIN
1

NOTES FOR -XX022 AND -XX022LF ONLY:

- ALL POSITIONS ARE LOADED WITH "A" EXCEPT WHERE NOTED.
- COLUMN 1, ROW A IS DESIGNATED AS SIGNAL PIN 1, AS VIEWED FROM THE MATING FACE.
- SIGNAL DATA FOR 50015-XX022 AND 50015-XX022LF:
SIZE 4 x 32
TOTAL NO. OF POSITIONS - 128
NO. OF POSITIONS LOADED - 128

ITEM KEY	QTY.	MATING LENGTH
A	113	.180/4.57
B	11	.260/6.60
C	4	.220/5.59

mat'l. code		surface		tolerance		projection		product family	
NOTE 4		ISO 1302 ✓		ISO 406 ISO 1101				HPC	
ltr	ecn no	dr	date	tolerances unless otherwise specified		INCH/MM		title	
S				angles	linear			4 ROW VERTICAL HEADER	
				0°±2'	.xxx±.005/.13			W/SOLDER TAIL PINS, 0 G.P.	
					.xxxx±.0020/.051			dwg no	
				dr	D.INGRAM	7/20/05	Amphenol FCi		sheet 3 of 4
				enr	D.HORCHLER	7/20/05			size
				chr	T.BREWBAKER	7/20/05			A3
				appd	D.HORCHLER	7/20/05			type
									Product Customer Drawing
sheet index	revision sheet								

PRODUCT NUMBER	NUMBER OF POSITIONS NOTE 3	TAIL LENGTH ±.015/0.38	CONTACT PLATING NOTE 12
50015-1YYA	YYY	.177/4.50	30u"/.76u Au
50015-1YYC	YYY	.533/13.54	30u"/.76u Au
50015-1YYD	YYY	.733/18.62	30u"/.76u Au
50015-1YYG	YYY	.250/6.35	30u"/.76u Au
50015-1YYYJ	YYY	.120/3.05	30u"/.76u Au
50015-3YYA	YYY	.177/4.50	50u"/1.27u Au
50015-3YYC	YYY	.533/13.54	50u"/1.27u Au
50015-3YYD	YYY	.733/18.62	50u"/1.27u Au
50015-3YYG	YYY	.250/6.35	50u"/1.27u Au
50015-3YYYJ	YYY	.120/3.05	50u"/1.27u Au
50015-5YYA	YYY	.177/4.50	30u"/.76u GXT
50015-5YYALF	YYY	.177/4.50	30u"/.76u GXT
50015-5YYC	YYY	.533/13.54	30u"/.76u GXT
50015-5YYCLF	YYY	.533/13.54	30u"/.76u GXT
50015-5YYD	YYY	.733/18.62	30u"/.76u GXT
50015-5YYDLF	YYY	.733/18.62	30u"/.76u GXT
50015-5YYG	YYY	.250/6.35	30u"/.76u GXT
50015-5YYGLF	YYY	.250/6.35	30u"/.76u GXT
50015-5YYYJ	YYY	.120/3.05	30u"/.76u GXT
50015-5YYYJLF	YYY	.120/3.05	30u"/.76u GXT
50015-XX022	128	.250/6.35	30u"/.76u Au
50015-XX022LF	128	.250/6.35	30u"/.76u GXT

NOTES:

1. PRODUCT NUMBERING CODE

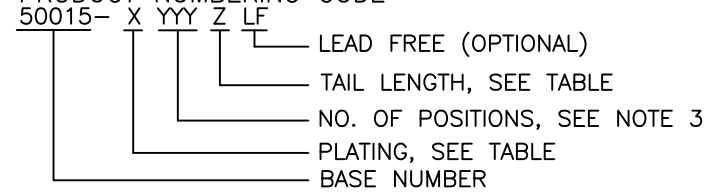

PRODUCT NUMBERING CODE FOR SELECT LOAD

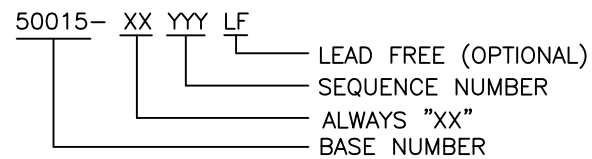

- ②. MANUFACTURE'S LOGO, PN, AND LOT CODE TO APPEAR ON THIS SURFACE.
- ③. THIS PRODUCT IS CONFIGURED IN SIZES OF 6 THRU 80 COLUMNS IN INCREMENTS OF ONE, i.e. 6, 7, 8, 9,79, 80.
- ④. MATERIAL:
HOUSING - GLASS AND MINERAL FILLED HIGH TEMPERTURE THERMOPLASTIC, FLAME RETARDANT PER UL94V-0. COLOR-BLACK
CONTACT - PHOS BRONZE
- 5. PLATING:
CONTACT AREA - SEE PRODUCT NUMBER TABLE
TAILS-EITHER TIN OR TIN LEAD, SEE PRODUCT NUMBER TABLE
- ⑥. DIMENSION "A" CALCULATION = .100 (2.54) X NO. OF COLUMNS + .75 (19.1)
- ⑦. DIMENSION "B" CALCULATION = .100 (2.54) X NO. OF COLUMNS + .450(11.43)
- ⑧. DIMENSION "C" CALCULATION = .100 (2.54) X NO. OF COLUMNS - .100(2.54)
- 9. ALL POSITIONS ARE LOADED EXCEPT FOR -XXYYY ASSEMBLIES WHICH HAVE SELECTIVE LOADING.
- 10. THIS PRODUCT (WITH "LF" SUFFIX) MEETS EUROPEAN UNION DIRECTIVES AND OTHER COUNTRY REGULATIONS AS DESCRIBED IN GS-22-008.
- 11. THIS HOUSING WILL WITHSTAND EXPOSURE TO 260°C PEAK TEMPERATURE FOR 10-30 SECONDS IN A CONVECTION, INFRA-RED OR VAPOR PHASE REFLOW OVEN.
- 12. PLATING OPTIONS:
MAY BE EITHER GOLD OR GXT PLATED AT MANUFACTURER'S OPTION

mat'l. code NOTE 4		surface ISO 1302 ✓	tolerance ISO 406 ISO 1101	projection 	product family HPC
ltr	ecn no	dr	date	tolerances unless otherwise specified	title 4 ROW VERTICAL HEADER W/SOLDER TAIL PINS, 0 G.P.
T				angles linear .XX±.01/.3 .XXX±.005/.13 .XXXX±.0020/.051	
				0'±2'	INCH/MM scale 1:1
		dr	D.INGRAM	7/20/05	Amphenol FCi dwg no 50015 sheet 4 of 4 size A3 type Product Customer Drawing
		enr	D.HORCHLER	7/20/05	
		chr	M JACOB	06/13/17	
		appd	BIJU K PAUL	06/13/17	
sheet index	revision sheet				