

LOC		DIST		REVISIONS			
P	LTR	DESCRIPTION	DATE	DWN	APVD		
	A	-	-	-	-	-	-
	B	-	-	-	-	-	-
	C	ECR-07-011431	05-06-07	BSV	MKO		

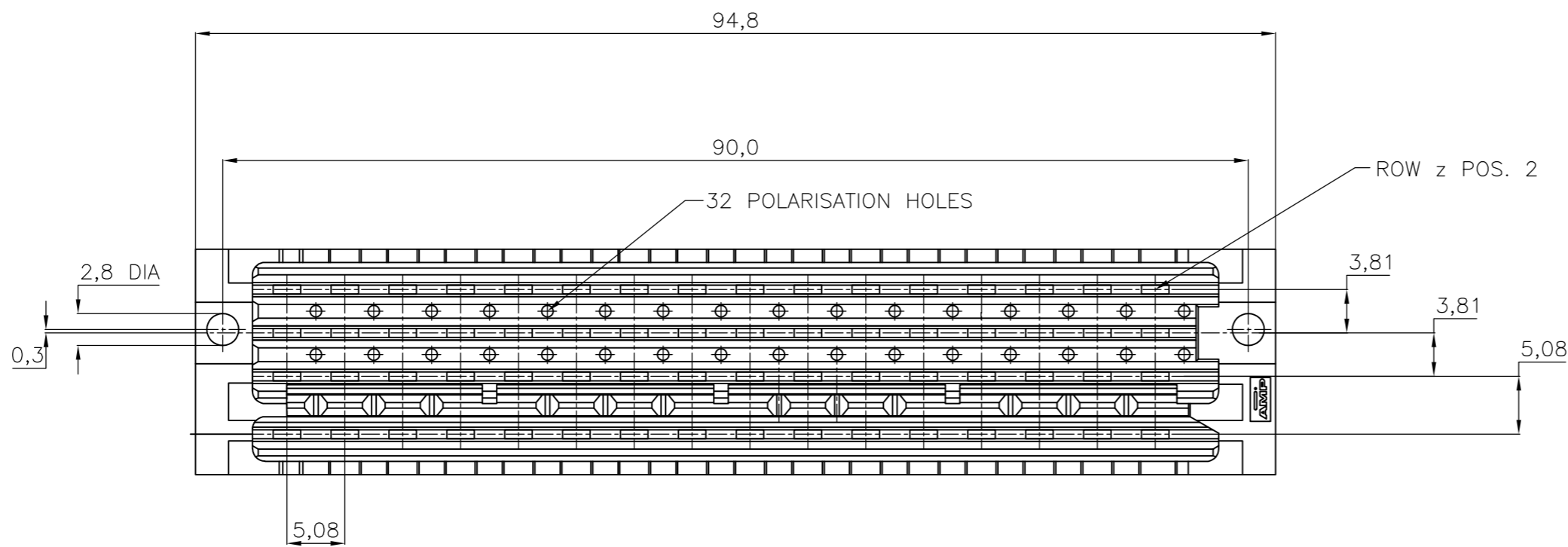

**NOTES:**



**MATERIAL:**  
 -HOUSING: G.F. THERMOPL. POLYESTER 94-V0  
 COLOUR: GREY  
 -CONTACTS: PHOSPHORBRONZE



**PLATING CONTACT:**  
 -1: 1,25 µm Au OVER 1,25 µm Ni AT CONTACT AREA,  
 REMAINDER 2,0µm Sn OVER 1,25 µm Ni  
 -4: SAME AS -1 ONLY 0,8µ Au AT CONTACT AREA  
 -7: SAME AS -1 ONLY 2,0µ Au AT CONTACT AREA  
 -8: SAME AS -1 ONLY 0,2µ Au AT CONTACT AREA



FOR PCB THICKNESS 2,4-3, 2.

P.C.B. HOLE DIM. ACTION PIN	
DRILLED HOLE	:1,75 ±1,25 mm
FIN. HOLE	:1,54 to 1,69 mm
AFTER REFLOW	:1,51 to 1,69 mm
Cu-thks	:0,025 to 0,075 mm
Sn-thks	:0,004 to 0,010 mm

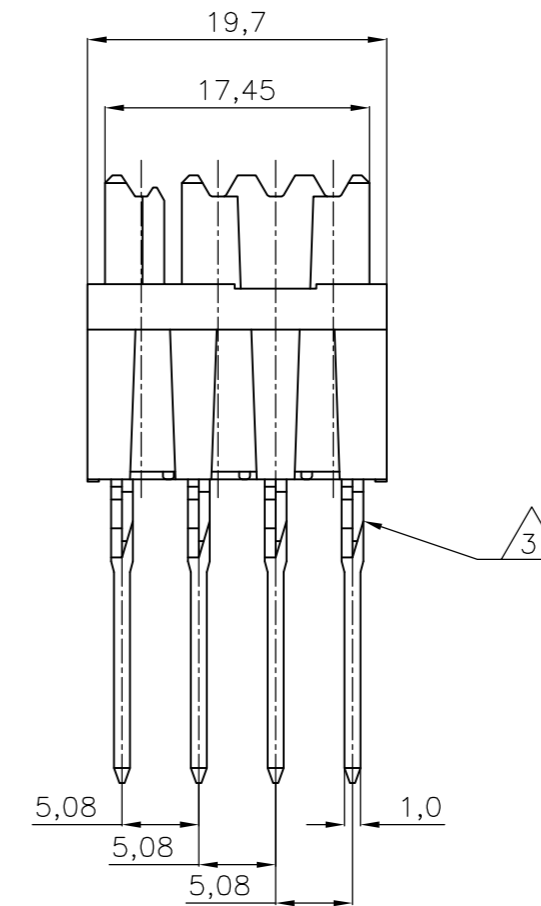
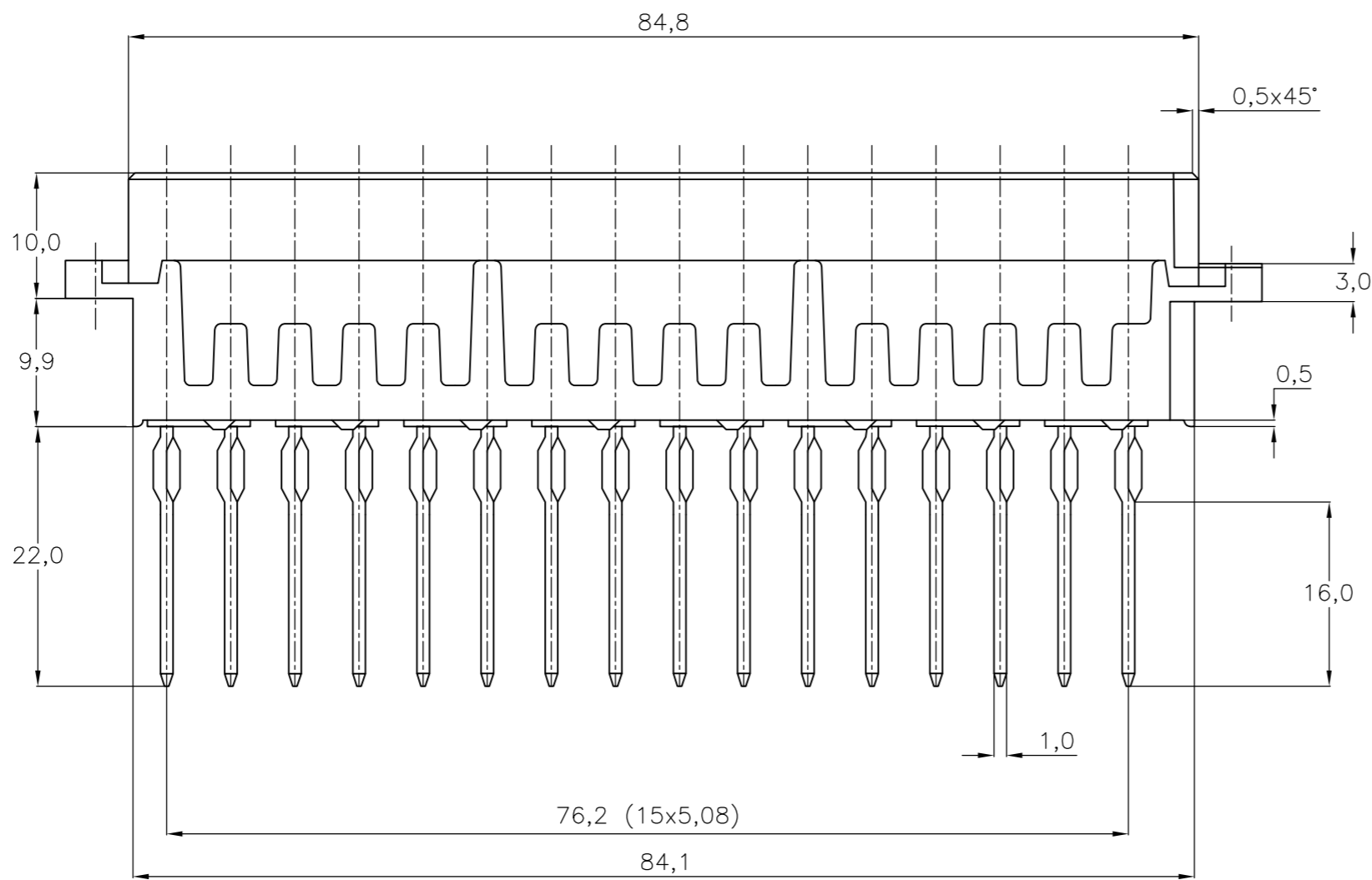

ROW	X	X	X	X	X	X	X	X	X	X	X	X	X	X	X	X	X	X	X	X	X	X
b	X	X	X	X	X	X	X	X	X	X	X	X	X	X	X	X	X	X	X	X	X	X
d	X	X	X	X	X	X	X	X	X	X	X	X	X	X	X	X	X	X	X	X	X	X
f	X	X	X	X	X	X	X	X	X	X	X	X	X	X	X	X	X	X	X	X	X	X
P.O.S.	32	30	28	26	24	22	20	18	16	14	12	10	8	6	4	2						

AN ASTERISK „X” DENOTES A CONTACT.

OBSOLETE	SEE NOTE	SEE NOTE	167771-8
OBSOLETE	2	1	167771-7
	FINISH	MATERIAL	167771-4
			167771-1
			PARTNUMBER

THIS DRAWING IS A CONTROLLED DOCUMENT.		DWN J.V.LIEMPT 29JAN91	Tyco Electronics Corporation s-Hertogenbosch, Nederland		
DIMENSIONS: mm		CHK J.V.GRUNSVEN 04FEB91	NAME L.V.SOEST		
TOLERANCES UNLESS OTHERWISE SPECIFIED: 0 PLC ± - 1 PLC ± - 2 PLC ± - 3 PLC ± - 4 PLC ± - ANGLES ± -		APVD L.V.SOEST 04FEB91	PRODUCT SPEC		
MATERIAL		APPLICATION SPEC		4x16 POS. TYPE G FEMALE WITH ACTION-PIN CONNECTOR PER DIN 41612	
FINISH		WEIGHT		RESTRICTED TO	
-		-		-	
CUSTOMER DRAWING			SCALE A2 00779	DRAWING NO C=167771	REVISION
			SHEET 1 OF 1		REV C