



Leading in-vehicle  
wireless charging

## WCT-15WTXAUTO Qi® Wireless Charging Transmitter Solution

The 15-watt, Qi-certified WCT-15WTXAUTO transmitter solution enables the convenience of fast and safe in-vehicle wireless charging of all the latest Qi smartphones.

### TARGET APPLICATIONS

- ▶ Qi mobile phone charging
- ▶ iPhone® 8 and X
- ▶ Samsung® Fast Charge

### OVERVIEW

Based on NXP's MWCT1011A/13A wireless charging IC, the automotive-grade WCT-15WTXAUTO multi-coil transmitter solution is compliant with the latest Wireless Power Consortium (WPC) Extended Power Profile specification. Our solution supports 15 W power transfer with over 70 percent WCT-15WTXAUTO DC input to RX DC battery output power transfer efficiency.

This fully certified Qi hardware reference design includes a professional-grade Qi-certified software library and flexible application.

### FEATURES

- ▶ MWCT1011A/13A wireless charging ICs
- ▶ Wireless Power Consortium (WPC) Qi Extended Power Profile (EPP) specification design
- ▶ NXP® low-power object detection technology or analog PING to detect a mobile device for charging while using the lowest possible standby power
- ▶ Dedicated design for automotive environment: supports free positioning with multiple coils, comparatively large Z-gap operation, comprehensive FOD, quick receiver removal detection, and fixed-frequency PWM control to reduce wide frequency spectrum EM emission
- ▶ NFC-enabled and CAN/LIN interface
- ▶ Automotive AEC-Q100 grade 2 certified
- ▶ NFC cards and ID protection



## NXP SUPPORT

NXP provides all the necessary hardware documentation: schematics, layout and assembly files, as well as a complete BOM. We also provide a firmware example project with a certified library that contains all the necessary wireless charging control blocks. Users access the library via an API which lets them interact with parameters and settings contained in the firmware, providing maximum control to the users. Customers can use a ready-to-use binary file from NXP or build an application around the firmware library.

## DEVELOPMENT TOOLS

Eclipse-based CodeWarrior® Development Studio for Microcontrollers

A complete integrated development environment (IDE) provides a highly visual and automated framework to accelerate the development of the most complex embedded applications.

## Easy-to-use Wireless Charging GUI

The easy-to-use FreeMASTER GUI tool has configuration, calibration and debugging functions to provide a user-friendly design experience and reduce time-to-market.

## WCT-15WTXAUTO MULTI-COIL WIRELESS POWER TRANSMITTER BLOCK DIAGRAM

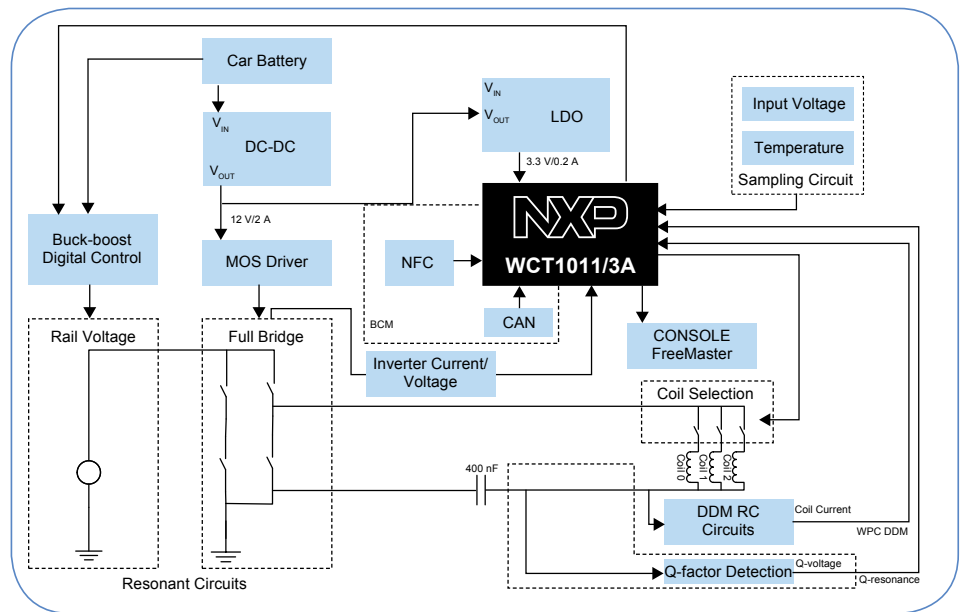

## WCT-15WTXAUTO FEATURES AND BENEFITS

Features	Benefits
Compliant with latest Extended Power Profile WPC Qi® specification	Ensures end solution meets latest industry specification
Transfer efficiency greater than 70%	Maximum energy transfer and lower thermal footprint
Meets Q-factor and latest power loss FOD requirements, as well as NFC card protection	Ensures foreign objects are detected and provides safety function
Supports any extended power profile receiver	Provides a broad range of customer designs with a single solution, including iPhone® 8, iPhone X and Samsung® Fast Charging
Low standby power	Low-power operating modes translate into lower power consumption during periods of inactivity
On-chip digital demodulation	Lower system bill of materials (BOM) and greater performance
On-chip DC/DC buck-boost control	Lower BOM and greater voltage accuracy
Supports operation frequency dithering technology	Eliminates AM band and key FOB interference
Open architecture software solution	Provides maximum design freedom and customer product differentiation
Meets AEC-Q100 (Grade 2) guidelines	Meets latest automotive requirements