

CKT SIZE	DIMENSION			
	A	B	C	D
2	6.10	4.70	2.00	3.00
3	8.10	6.70	4.00	5.00
4	10.10	8.70	6.00	7.00
5	12.10	10.70	8.00	9.00
6	14.10	12.70	10.00	11.00
7	16.10	14.70	12.00	13.00
8	18.10	16.70	14.00	15.00
9	20.10	18.70	16.00	17.00
10	22.10	20.70	18.00	19.00

RECOMMENDED PCB LAYOUT
GENERAL TOLERANCE: ±0.05

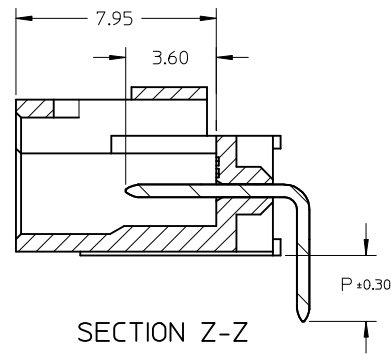
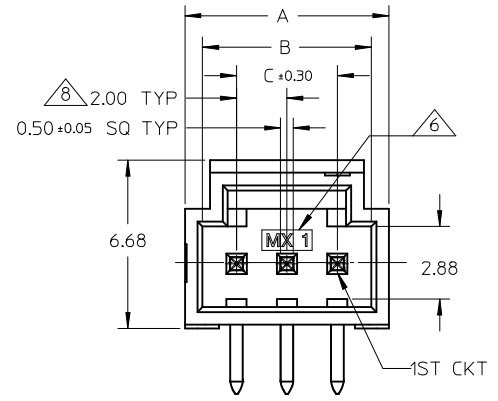
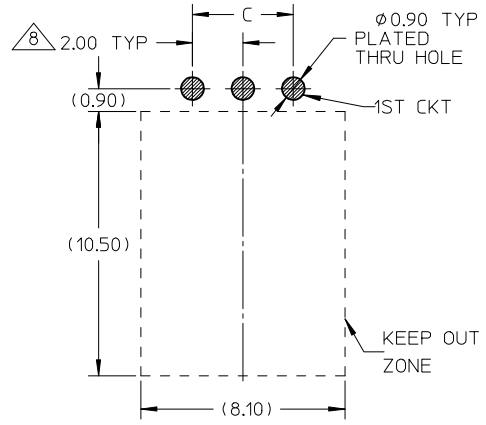
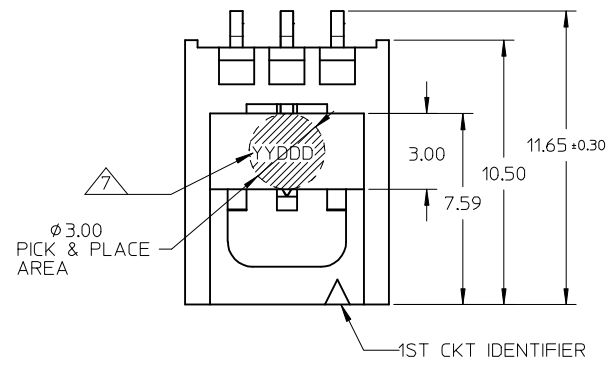

NOTES:

1. MATERIAL:
HOUSING: LIQUID CRYSTALLINE POLYMERS(LCP), GLASS FILLED, UL94V-0, BLACK.
PIN: COPPER ALLOY, 0.50MM SQ
2. PLATING: SEE TABLE.
3. PRODUCT SPECIFICATION: PS-151062-0001.
4. PACKAGING SPECIFICATION: PK-151062-0001.
5. TO BE MATED WITH MOLEX RECEPTACLES SERIES: 151100.
6. MANUFACTURING ID & CAVITY ID SHALL BE LOCATED APPROXIMATELY AS SHOWN.
7. DATE CODE: YYDDD IS LOCATED APPROXIMATELY AS SHOWN.
8. PITCH TOLERANCE SHALL BE NON ACCUMULATED.

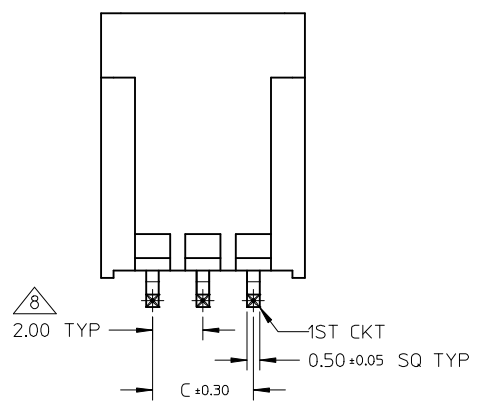

RELEASE TO REV A EC NO: S2016-0665 DRWN:FCS00 2016/01/27 CHKD:CGOH 2016/02/16 APPR:KHLIM 2016/02/16	QUALITY SYMBOLS $\nabla_A = 0$ $\nabla_C = 0$ $\nabla_P = 0$	GENERAL TOLERANCES (UNLESS SPECIFIED)		DIMENSION STYLE MM ONLY		SCALE NTS	DESIGN UNITS METRIC	THIRD ANGLE PROJECTION		
		mm	INCH	DRAWN BY	DATE	TITLE				
		4 PLACES ± ---	± ---	FCS00	2014/12/19	SALES DRAWING PCB HEADER, RA TH SINGLE ROW MILLIGRID molex				
		3 PLACES ± ---	± ---	CHECKED BY	DATE					
2 PLACES ± 0.20	± ---	FCS00	2014/12/19	MATERIAL NO. DOCUMENT NO. SD-151065-0001 SHEET NO. 1 OF 3						
1 PLACE ± ---	± ---	APPROVED BY	DATE							
0 PLACE ± ---	± ---	KHLIM	2015/07/02	THIS DRAWING CONTAINS INFORMATION THAT IS PROPRIETARY TO MOLEX INCORPORATED AND SHOULD NOT BE USED WITHOUT WRITTEN PERMISSION						
ANGULAR ± 3 °		DRAFT WHERE APPLICABLE MUST REMAIN WITHIN DIMENSIONS							SIZE A3	

RECOMMENDED PCB LAYOUT
GENERAL TOLERANCE: ±0.05

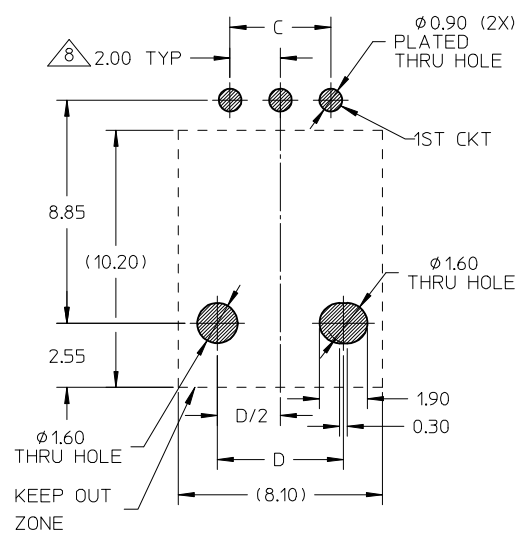
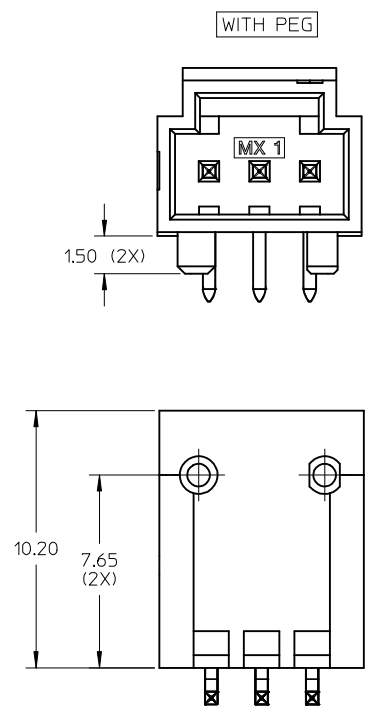

RELEASE TO REV A EC NO: S2016-0665 DRWN:FCS00 2016/01/27 CHKD:CGOH 2016/02/16 APPR:KHLIM 2016/02/16	DESCRIPTION REV	QUALITY SYMBOLS	GENERAL TOLERANCES (UNLESS SPECIFIED)	DIMENSION STYLE MM ONLY	SCALE NTS	DESIGN UNITS METRIC	THIRD ANGLE PROJECTION																																	
		$\nabla_A = 0$ $\nabla_C = 0$ $\nabla_P = 0$	<table border="1"> <tr><th></th><th>mm</th><th>INCH</th></tr> <tr><td>4 PLACES</td><td>± ---</td><td>± ---</td></tr> <tr><td>3 PLACES</td><td>± ---</td><td>± ---</td></tr> <tr><td>2 PLACES</td><td>± 0.20</td><td>± ---</td></tr> <tr><td>1 PLACE</td><td>± ---</td><td>± ---</td></tr> <tr><td>0 PLACE</td><td>± ---</td><td>± ---</td></tr> </table>		mm	INCH	4 PLACES	± ---	± ---	3 PLACES	± ---	± ---	2 PLACES	± 0.20	± ---	1 PLACE	± ---	± ---	0 PLACE	± ---	± ---	<table border="1"> <tr><th>DRAWN BY</th><th>DATE</th><th>TITLE</th></tr> <tr><td>FCS00</td><td>2014/12/19</td><td rowspan="3">SALES DRAWING PCB HEADER, RA TH SINGLE ROW MILLIGRID</td></tr> <tr><th>CHECKED BY</th><th>DATE</th></tr> <tr><td>FCS00</td><td>2014/12/19</td></tr> <tr><th>APPROVED BY</th><th>DATE</th></tr> <tr><td>KHLIM</td><td>2015/07/02</td></tr> </table>	DRAWN BY	DATE	TITLE	FCS00	2014/12/19	SALES DRAWING PCB HEADER, RA TH SINGLE ROW MILLIGRID	CHECKED BY	DATE	FCS00	2014/12/19	APPROVED BY	DATE	KHLIM	2015/07/02				
			mm	INCH																																				
		4 PLACES	± ---	± ---																																				
3 PLACES	± ---	± ---																																						
2 PLACES	± 0.20	± ---																																						
1 PLACE	± ---	± ---																																						
0 PLACE	± ---	± ---																																						
DRAWN BY	DATE	TITLE																																						
FCS00	2014/12/19	SALES DRAWING PCB HEADER, RA TH SINGLE ROW MILLIGRID																																						
CHECKED BY	DATE																																							
FCS00	2014/12/19																																							
APPROVED BY	DATE																																							
KHLIM	2015/07/02																																							
	ANGULAR ± 3 °	MATERIAL NO.	DOCUMENT NO.																																					
	DRAFT WHERE APPLICABLE MUST REMAIN WITHIN DIMENSIONS	SEE TABLE	SD-151065-0001			SHEET NO. 2 OF 3																																		

ASSEMBLY

151065 - X X X X

02 - 10	2-10 CKT W/O PEG
52 - 60	2-10 CKT WITH PEG
	52 = 2CKT
	53 = 3CKT
	.
	59 = 9CKT
	60 = 10CKT

PLATING	
0	FULL TIN
1	Au FLASH
2	0.38 Au
3	0.75 Au
4	OTHER OPTIONS
5	
6	
7	
8	
9	

	P TAIL LENGTH	PACKAGING
0	2.60	TAPE & REEL
1	3.60	
2	4.60	
3	2.60	TUBE
4	3.60	
5	4.60	
6		OTHER OPTIONS
7		
8		
9		

PLATING OPTIONS	
-*0**	2.50µm MIN. TIN ON CONTACT AND 2.00µm MIN. TIN ON SOLDERTAIL OVER 1.25µm MIN. NICKEL OVERALL
-*1**	0.05µm MIN. GOLD PLATE ON CONTACT AND 2.00µm MIN. TIN (MATTE) ON SOLDERTAIL OVER 1.25µm MIN. NICKEL OVERALL.
-*2**	0.38µm MIN. GOLD PLATE ON CONTACT AND 2.00µm MIN. TIN (MATTE) ON SOLDERTAIL OVER 1.25µm MIN. NICKEL OVERALL.
-*3**	0.75µm MIN. GOLD PLATE ON CONTACT AND 2.00µm MIN. TIN (MATTE) ON SOLDERTAIL OVER 1.25µm MIN. NICKEL OVERALL.

PACKAGING OPTION AND CAP	
TAPE & REEL	151000-4***
PACKAGING TUBE	151000-3015
P TAIL LENGTH	RECOMMENDED PCB THICKNESS
2.60	1.50
3.60	2.50
4.60	3.50

RELEASE TO REV A EC NO: S2016-0665 DRWN:FCS00 2016/01/27 CHKD:CGOH 2016/02/16 APPR:KHLIM 2016/02/16	REV DESCRIPTION A	QUALITY SYMBOLS	GENERAL TOLERANCES (UNLESS SPECIFIED)	DIMENSION STYLE	SCALE	DESIGN UNITS	THIRD ANGLE PROJECTION	
		$F_A=0$ $F_G=0$ $F_P=0$	mm INCH 4 PLACES ± --- ± --- 3 PLACES ± --- ± --- 2 PLACES ± 0.20 ± --- 1 PLACE ± --- ± --- 0 PLACE ± --- ± ---	MM ONLY	NTS	METRIC	TITLE SALES DRAWING PCB HEADER, RA TH SINGLE ROW MILLIGRID	
		ANGULAR ± 3 ° DRAFT WHERE APPLICABLE MUST REMAIN WITHIN DIMENSIONS	DRAWN BY DATE FCS00 2014/12/19 CHECKED BY DATE FCS00 2014/12/19 APPROVED BY DATE KHLIM 2015/07/02	MATERIAL NO. SEE TABLE	DOCUMENT NO. SD-151065-0001	SHEET NO. 3 OF 3		
		THIS DRAWING CONTAINS INFORMATION THAT IS PROPRIETARY TO MOLEX INCORPORATED AND SHOULD NOT BE USED WITHOUT WRITTEN PERMISSION						