

Dual Power Distribution Controller

The ISL6161 is a HOT SWAP dual supply power distribution controller that can be used in PCI-Express applications.

Two external N-Channel MOSFETs are driven to distribute and control power while providing load fault isolation. At turn-on, the gate of each external N-Channel MOSFET is charged with a 10 μ A current source. Capacitors on each gate (see the "Typical Application Diagram" on page 1), create a programmable ramp (soft turn-on) to control in-rush currents. A built-in charge pump supplies the gate drive for the 12V supply N-Channel MOSFET switch.

Overcurrent protection is facilitated by two external current sense resistors and FETs. When the current through either resistor exceeds the user programmed value, the controller enters the current regulation mode. The time-out capacitor, C_{TIM}, starts charging as the controller enters the time-out period. Once C_{TIM} charges to a 2V threshold, both the N-Channel MOSFETs are latched off. In the event of a hard and fast fault of at least 3x the programmed current limit level, the N-Channel MOSFET gates are pulled low immediately before entering the time-out period. The controller is reset by a rising edge on the ENABLE pin.

The ISL6161 constantly monitors both output voltages and reports either one being low on the PGOOD output as a low. The 12V PGOOD V_{th} is ~10.8V and the 3.3V V_{th} is ~2.8V nominally.

Pinout

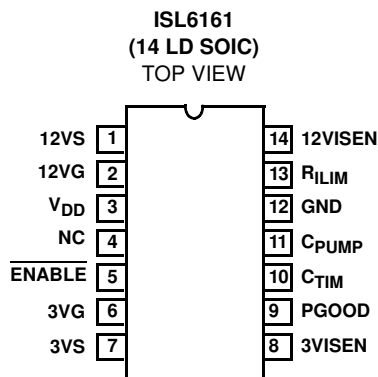

Features

- HOT SWAP Dual Power Distribution and Control for +12V and +3.3V
- Provides Fault Isolation
- Programmable Current Regulation Level
- Programmable Time-Out
- Charge Pump Allows the Use of N-Channel MOSFETs
- Power-Good and Overcurrent Latch Indicators
- Adjustable Turn-On Ramp
- Protection During Turn-On
- Two Levels of Current Limit Detection Provide Fast Response to Varying Fault Conditions
- 1 μ s Response Time to Dead Short
- 3 μ s Response Time to 200% Current Overshoot
- Pb-Free Available (RoHS compliant)

Applications

- PCI-Express Applications
- Power Distribution and Control
- Hot Plug, Hot Swap Components

Ordering Information

PART NUMBER	PART MARKING	TEMP. RANGE (°C)	PACKAGE	PKG. DWG. #
ISL6161BZA* (Note)	ISL6161 IBZ	-40 to +85	14 Ld SOIC (Pb-free)	M14.15
ISL6161CB*	ISL6161CB	0 to +70	14 Ld SOIC	M14.15
ISL6161CBZA* (Note)	6161CBZ	0 to +70	14 Ld SOIC (Pb-free)	M14.15

*Add "-T" suffix for tape and reel. Please refer to TB347 for details on reel specifications.

NOTE: These Intersil Pb-free plastic packaged products employ special Pb-free material sets, molding compounds/die attach materials, and 100% matte tin plate plus anneal (e3 termination finish, which is RoHS compliant and compatible with both SnPb and Pb-free soldering operations). Intersil Pb-free products are MSL classified at Pb-free peak reflow temperatures that meet or exceed the Pb-free requirements of IPC/JEDEC J STD-020

Typical Application Diagram

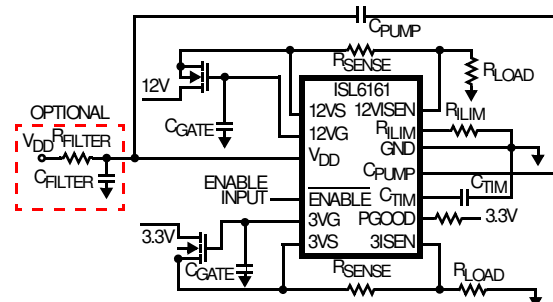

Simplified Schematic

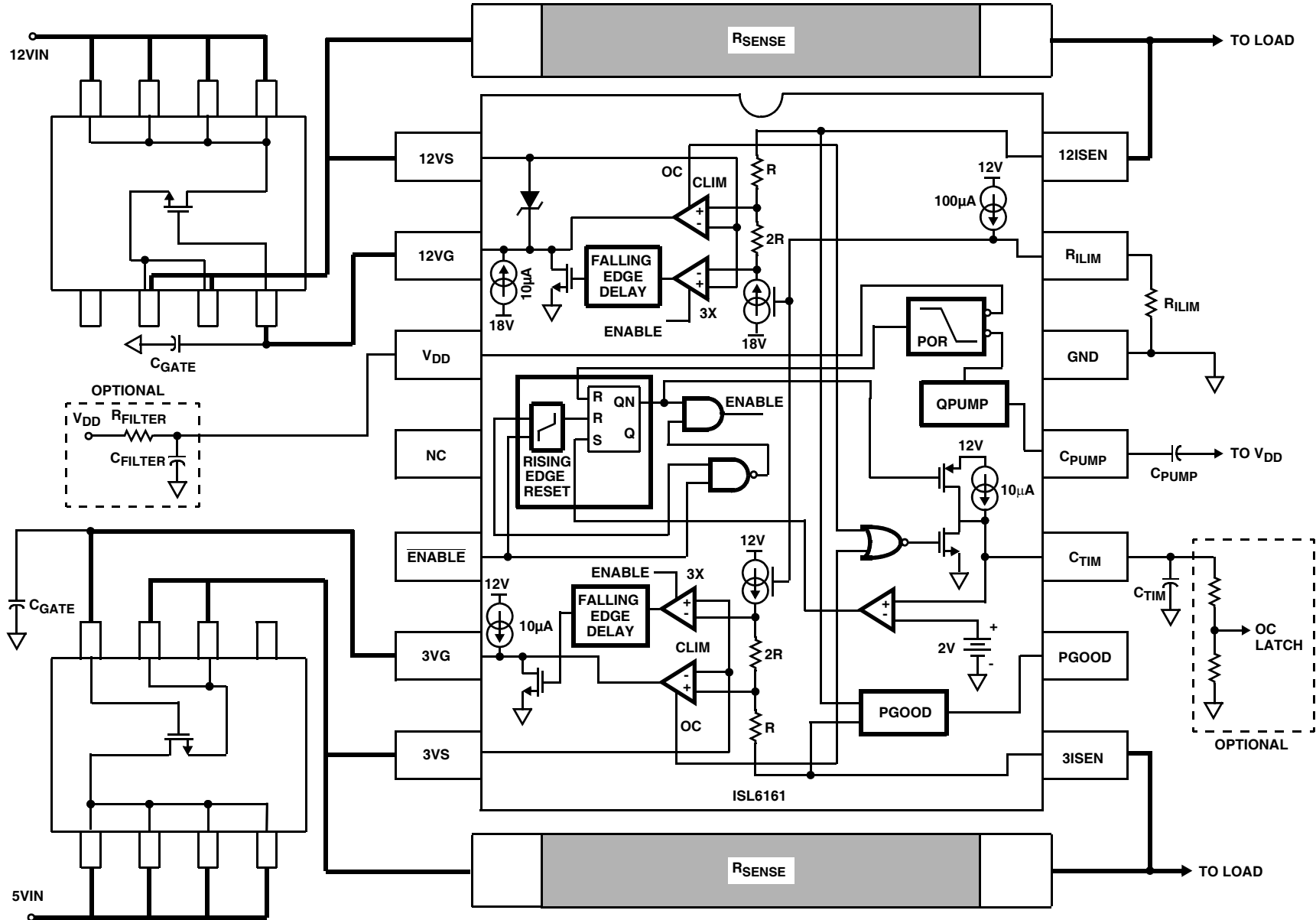

ISL6161

Pin Descriptions

PIN NUMBER	SYMBOL	FUNCTION	DESCRIPTION
1	12VS	12V Source	Connect to source of associated external N-Channel MOSFET switch to sense output voltage.
2	12VG	12V Gate	Connect to the gate of associated N-Channel MOSFET switch. A capacitor from this node to ground sets the turn-on ramp. At turn-on this capacitor will be charged to ~17.4V by a 10 μ A current source.
3	V _{DD}	Chip Supply	Connect to 12V supply. This can be either connected directly to the +12V rail supplying the load voltage or to a dedicated V _{DD} +12V supply. If the former is chosen, special attention to V _{DD} decoupling must be paid to prevent sagging as heavy loads are switched on.
4	NC	Not Connected	
5	$\overline{\text{ENABLE}}$	Enable/Reset	$\overline{\text{ENABLE}}$ is used to turn-on and reset the chip. Both outputs turn-on when this pin is driven low. After a current limit time-out, the chip is reset by the rising edge of a reset signal applied to the ENABLE pin. This input has 100 μ A pull-up capability, which is compatible with 3V and 5V open drain and standard logic.
6	3VG	3V Gate	Connect to the gate of the external 3V N-Channel MOSFET. A capacitor from this node to ground sets the turn-on ramp. At turn-on, this capacitor will be charged to ~11.4V by a 10 μ A current source.
7	3VS	3 Source	Connect to the source side of 3V external N-Channel MOSFET switch to sense output voltage.
8	3VISEN	3V Current Sense	Connect to the load side of the 3V sense resistor to measure the voltage drop across this resistor between 3VS and 3VISEN pins.
9	PGOOD	Power-Good indicator	Indicates that all output voltages are within specification. PGOOD is driven by an open drain N-Channel MOSFET. It is pulled low when any output is not within specification.
10	C _{TIM}	Current Limit Timing Capacitor	Connect a capacitor from this pin to ground. This capacitor controls the time between the onset of current limit and chip shutdown (current limit time-out). The duration of current limit time-out (in seconds) = 200k Ω x C _{TIM} (Farads).
11	C _{PUMP}	Charge Pump Capacitor	Connect a 0.1 μ F capacitor between this pin and V _{DD} (pin 3). Provides charge storage for 12VG drive.
12	GND	Chip Ground	
13	R _{ILIM}	Current Limit Set Resistor	A resistor connected between this pin and ground determines the current level at which current limit is activated. This current is determined by the ratio of the R _{ILIM} resistor to the sense resistor (R _{SENSE}). The current at current limit onset is equal to 10 μ A x (R _{ILIM} /R _{SENSE}). The ISL6161 is limited to a 10k Ω min. value (OC V _{th} = 100mV) resistor whereas the ISL6161 can accommodate a 5k Ω resistor for a lower OC V _{th} (50mV).
14	12VISEN	12V Current Sense	Connect to the load side of sense resistor to measure the voltage drop across this resistor.

ISL6161

Absolute Maximum Ratings $T_A = +25^\circ\text{C}$

V_{DD}	-0.3V to +16V
12VG, C_{PUMP}	-0.3V to 21V
12VISEN, 12VS	-5V to $V_{DD} + 0.3\text{V}$
3VISEN, 3VS	-5V to 7.5V
PGOOD, R_{ILIM}	-0.3V to 7.5V
ENABLE, C_{TIM} , 3VG	-0.3V to $V_{DD} + 0.3\text{V}$
ESD Classification	2kV (Class 2)

Thermal Information

Thermal Resistance (Typical, Note 1)	θ_{JA} ($^\circ\text{C}/\text{W}$)
SOIC Package	67
Maximum Junction Temperature (Plastic Package)	+150 $^\circ\text{C}$
Maximum Storage Temperature Range	-65 $^\circ\text{C}$ to +150 $^\circ\text{C}$
Pb-Free Reflow Profile	see link below
http://www.intersil.com/pbfree/Pb-FreeReflow.asp	

Operating Conditions

V_{DD} Supply Voltage Range	+10.5V to +13.2V
Temperature Range (T_A)	
ISL6161IB	-40 $^\circ\text{C}$ to +85 $^\circ\text{C}$
ISL6161CB	0 $^\circ\text{C}$ to +70 $^\circ\text{C}$

CAUTION: Do not operate at or near the maximum ratings listed for extended periods of time. Exposure to such conditions may adversely impact product reliability and result in failures not covered by warranty.

NOTES:

- θ_{JA} is measured with the component mounted on a high effective thermal conductivity test board in free air. See Tech Brief TB379 for details.
- All voltages are relative to GND, unless otherwise specified.

Electrical Specifications $V_{DD} = 12\text{V}$, $C_{VG} = 0.01\mu\text{F}$, $C_{TIM} = 0.1\mu\text{F}$, $R_{SENSE} = 0.1\Omega$, $C_{BULK} = 220\mu\text{F}$, $\text{ESR} = 0.5\Omega$, $T_A = T_J = -40^\circ\text{C}$ to +85 $^\circ\text{C}$, Unless Otherwise Specified. Parameters with MIN and/or MAX limits are 100% tested at +25 $^\circ\text{C}$, unless otherwise specified. Temperature limits established by characterization and are not production tested.

PARAMETER	SYMBOL	TEST CONDITIONS	MIN	TYP	MAX	UNITS
12V CONTROL SECTION						
Current Limit Threshold Voltage (Voltage Across Sense Resistor)	V_{IL12V}	$R_{ILIM} = 10\text{k}\Omega$	92	100	108	mV
		$R_{ILIM} = 5\text{k}\Omega$	47	53	59	mV
3x Current Limit Threshold Voltage (Voltage Across Sense Resistor)	$3 \times V_{IL12V}$	$R_{ILIM} = 10\text{k}\Omega$	250	300	350	mV
		$R_{ILIM} = 5\text{k}\Omega$	100	165	210	mV
$\pm 20\%$ Current Limit Response Time (Current within 20% of Regulated Value)	20%iLrt	200% Current Overload, $R_{ILIM} = 10\text{k}\Omega$, $R_{SHORT} = 6.0\Omega$	-	2	-	μs
$\pm 10\%$ Current Limit Response Time (Current within 10% of Regulated Value)	10%iLrt	200% Current Overload, $R_{ILIM} = 10\text{k}\Omega$, $R_{SHORT} = 6.0\Omega$	-	4	-	μs
$\pm 1\%$ Current Limit Response Time (Current within 1% of Regulated Value)	1%iLrt	200% Current Overload, $R_{ILIM} = 10\text{k}\Omega$, $R_{SHORT} = 6.0\Omega$	-	10	-	μs
Response Time to Dead Short	R_{TSHORT}	$C_{12VG} = 0.01\mu\text{F}$	-	500	-	ns
Gate Turn-On Time	t_{ON12V}	$C_{12VG} = 0.01\mu\text{F}$	-	12	-	ms
Gate Turn-On Current	I_{ON12V}	$C_{12VG} = 0.01\mu\text{F}$	8	10	12	μA
3x Gate Discharge Current	3Xdisl	12VG = 18V	-	0.75	-	A
12V Undervoltage Threshold	12V V_{UV}		10.5	10.8	11.0	V
Charge Pumped 12VG Voltage	V12VG	$C_{PUMP} = 0.1\mu\text{F}$	16.8	17.3	17.9	V
3.3V CONTROL SECTION						
Current Limit Threshold Voltage (Voltage Across Sense Resistor)	V_{IL3V}	$R_{ILIM} = 10\text{k}\Omega$	92	100	108	mV
		$R_{ILIM} = 5\text{k}\Omega$	47	53	59	mV
3x Current Limit Threshold Voltage (Voltage Across Sense Resistor)	$3 \times V_{IL3V}$	$R_{ILIM} = 10\text{k}\Omega$	250	300	350	mV
		$R_{ILIM} = 5\text{k}\Omega$	100	155	210	mV
$\pm 20\%$ Current Limit Response Time (Current within 20% of Regulated Value)		200% Current Overload, $R_{ILIM} = 10\text{k}\Omega$, $R_{SHORT} = 2.5\Omega$	-	2	-	μs
$\pm 10\%$ Current Limit Response Time (Current within 10% of Regulated Value)		200% Current Overload, $R_{ILIM} = 10\text{k}\Omega$, $R_{SHORT} = 2.5\Omega$	-	4	-	μs

Electrical Specifications $V_{DD} = 12V$, $C_{VG} = 0.01\mu F$, $C_{TIM} = 0.1\mu F$, $R_{SENSE} = 0.1\Omega$, $C_{BULK} = 220\mu F$, $ESR = 0.5\Omega$, $T_A = T_J = -40^\circ C$ to $+85^\circ C$, Unless Otherwise Specified. Parameters with MIN and/or MAX limits are 100% tested at $+25^\circ C$, unless otherwise specified. Temperature limits established by characterization and are not production tested. (Continued)

PARAMETER	SYMBOL	TEST CONDITIONS	MIN	TYP	MAX	UNITS
$\pm 1\%$ Current Limit Response Time (Current within 1% of Regulated Value)		200% Current Overload, $R_{ILIM} = 10k\Omega$, $R_{SHORT} = 2.5\Omega$	-	10	-	μs
Response Time To Dead Short	RT_{SHORT}	$C_{VG} = 0.01\mu F$	-	500		ns
Gate Turn-On Time	t_{ON3V}	$C_{VG} = 0.01\mu F$	-	5	-	ms
Gate Turn-On Current	I_{ON3V}	$C_{VG} = 0.01\mu F$	8	10	12	μA
3x Gate Discharge Current	3xdisl	$C_{VG} = 0.01\mu F$, ENABLE = Low		0.75	-	A
3.3V Undervoltage Threshold	3.3V _{VUV}		2.7	2.85	3.0	V
3.3VG High Voltage	3VG		11.2	11.9	-	V
SUPPLY CURRENT AND IO SPECIFICATIONS						
V_{DD} Supply Current	I_{VDD}		4	8	10	mA
V_{DD} POR Rising Threshold			9.5	10.0	10.7	V
V_{DD} POR Falling Threshold			9.0	9.4	9.8	V
Current Limit Time-Out	t_{ILIM}	$C_{TIM} = 0.1\mu F$	-	20	-	ms
\overline{ENABLE} Pull-up Voltage	PWRN_V	\overline{ENABLE} pin open	1.8	2.4	3.2	V
\overline{ENABLE} Rising Threshold	PWR_Vth		1.1	1.5	2	V
\overline{ENABLE} Hysteresis	PWR_hys		0.1	0.2	0.3	V
\overline{ENABLE} Pull-Up Current	PWRN_I		60	80	100	μA
Current Limit Time-Out Threshold (C_{TIM})	C_{TIM_Vth}		1.8	2	2.2	V
C_{TIM} Charging Current	C_{TIM_I}		8	10	12	μA
C_{TIM} Discharge Current	C_{TIM_disl}		1.7	2.6	3.5	mA
C_{TIM} Pull-Up Current	C_{TIM_disl}	$V_{CTIM} = 8V$	3.5	5	6.5	mA
R_{ILIM} Pin Current Source Output	R_{ILIM_Io}		90	100	110	μA
Charge Pump Output Current	Qpmp_Io	$C_{PUMP} = 0.1\mu F$, $C_{PUMP} = 16V$	320	560	900	μA
Charge Pump Output Voltage	Qpmp_Vo	No load	17.2	17.4	-	V
Charge Pump Output Voltage - Loaded	Qpmp_Vlo	Load current = $100\mu A$	16.2	16.7	-	V
Charge Pump POR Rising Threshold	Qpmp + Vth		15.6	16	16.5	V
Charge Pump POR Falling Threshold	Qpmp - Vth		15.2	15.7	16.2	V

ISL6161 Description and Operation

The ISL6161 is a multi-featured +12V and +3.3V dual power supply distribution controller. Its features include programmable current regulation (CR) limiting and time to latch off.

At turn-on, the gate capacitor of each external N-Channel MOSFET is charged with a $10\mu A$ current source. These capacitors create a programmable ramp (soft turn-on). A charge pump supplies the gate drive for the 12V supply control FET switch driving that gate to 17V.

The load currents pass through two external current sense resistors. When the voltage across either resistor quickly exceeds the user programmed Current Regulation voltage threshold (CRVth) level, the controller enters current regulation. The CRVth is set by the external resistor value on R_{ILIM} pin. At

this time, the time-out capacitor, C_{TIM} , starts charging with a $10\mu A$ current source and the controller enters the time-out period. The length of the time-out period is set by the single external capacitor (see Table 2) placed from the C_{TIM} pin (pin 10) to ground and is characterized by a lowered gate drive voltage to the appropriate external N-Channel MOSFET. Once C_{TIM} charges to 2V, an internal comparator is tripped resulting in both N-Channel MOSFETs being latched off. If the voltage across the sense resistors rises slowly in response to an OC condition, then the CR mode is entered at $\sim 95\%$ of the programmed CR level. This difference is due to the necessary hysteresis and response time in the CR control circuitry.

Table 1 shows R_{SENSE} and R_{ILIM} recommendations and resulting CR level for the PCI-Express add-in card connector sizes specified.

TABLE 1. R_{SENSE} AND R_{ILIM} RECOMMENDATIONS

PCI-EXPRESS ADD-IN CARD CONNECTOR	R_{ILIM} (k Ω)	3.3V R_{SENSE} (m Ω), NOMINAL CR (A)	12V R_{SENSE} (m Ω), NOMINAL CR (A)	NOMINAL CRVth (mV)
X1	10	30, 3.3	150, 0.7	100
	4.99	15, 3.5	90, 0.6	53
X4/X8	10	30, 3.3	40, 2.5	100
	4.99	15, 3.5	20, 2.6	53
X16	10	30, 3.3	16, 6.3	100
	4.99	15, 3.5	8, 6.6	53

NOTE: Nominal CR Vth = $R_{ILIM} \times 10\mu A$.

TABLE 2.

C_{TIM} CAPACITOR (μF)	NOMINAL TIME-OUT PERIOD (ms)
0.022	4.4
0.047	9.4
0.1	20

NOTE: Nominal time-out period in seconds = $C_{TIM} \times 200k\Omega$.

The ISL6161 responds to a load short (defined as a current level 3x the OC set point with a fast transition) by immediately driving the relevant N-Channel MOSFET gate to 0V in $\sim 3\mu s$. The gate voltage is then slowly ramped up, soft-starting the N-Channel MOSFET to the programmed current regulation limit level. This is the start of the time-out period if the abnormal load condition still exists. The programmed current regulation level is held until either the OC event passes or the time-out period expires. If the former is the case, then the N-Channel MOSFET is fully enhanced and the C_{TIM} charging current is diverted away from the capacitor. If the time-out period expires prior to OC resolution, then both gates are quickly pulled to 0V turning off both N-Channel MOSFETs simultaneously.

Upon any UV condition, the PGOOD signal will pull low when tied high through a resistor to the logic supply. This pin is a fault indicator but not the OC latch-off indicator. For an OC latch-off indication, monitor CTIM, pin 10. This pin will rise rapidly to 12V once the time-out period expires. See "Simplified Schematic" on page 2 for OC latch-off circuit suggestion.

The ISL6161 is reset by a rising edge on the \overline{ENABLE} pin and is turned on by the \overline{ENABLE} pin being driven low.

ISL6161 Application Considerations

In a non PCI-Express, motor drive application, **Current loop stabilization** is facilitated through a small value resistor in series with the gate timing capacitor. As the ISL6161 drives a highly inductive current load, instability characterized by the gate voltage repeatedly ramping up and down may appear. A simple method to enhance stability is provided by the substitution of a larger value gate resistor. Typically, this situation can be avoided by eliminating long point-to-point wiring to the load.

With the ENABLE internal pull-up, the ISL6161 is well suited for implementation on either side of the connector where a motherboard prebiased condition or a load board staggered connection is present. In either case, the ISL6161 turns on in a soft-start mode protecting the supply rail from sudden current loading.

During the **Time-Out delay period** with the ISL6161 in current limit mode, the V_{GS} of the external N-Channel MOSFETs is reduced driving the N-Channel MOSFET switch into a high $r_{DS(ON)}$ state. Thus, avoid extended time-out periods as the external N-Channel MOSFETs may be damaged or destroyed due to excessive internal power dissipation. Refer to the MOSFET manufacturers data sheet for SOA information.

With the high levels of in-rush current e.g., highly capacitive loads and motor start-up currents, **choosing the current regulation (CR) level** is crucial to provide both protection and still allow for this in-rush current without latching off. Consider this in addition to the time-out delay when choosing MOSFETs for your design.

Physical layout of R_{SENSE} resistors is critical to avoid inadvertently lowering the CR and trip levels. Ideally, trace routing between the R_{SENSE} resistors and the ISL6161 should be as direct and as short as possible with zero current in the sense lines.

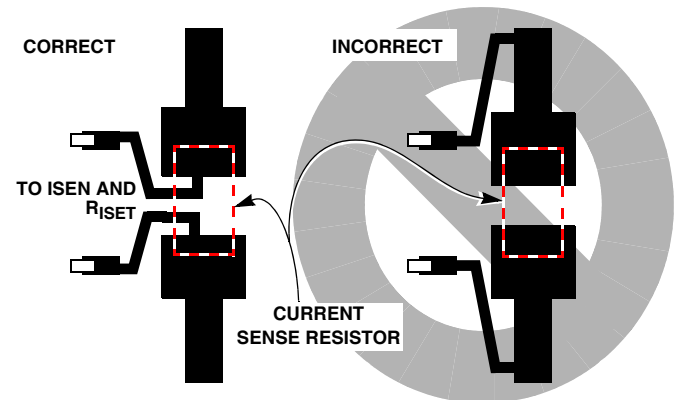

FIGURE 1. SENSE RESISTOR PCB LAYOUT

Open load detection can be accomplished by monitoring the ISEN pins. Although gated off, the external FET I_{DSS} will cause the ISEN pin to float above ground to some voltage when there is no attached load. If this is not desired, 5k resistors from the xISEN pins to ground will prevent the outputs from floating when the external switch FETs are disabled and the outputs are open.

For **PCI-Express applications**, the ISL6161 and the ISL6118 provide the fundamental hotswap function for the +12V and +3.3V main rails and the +3.3V aux respectively, as shown in the “PCI-Express Implementation of ISL6161 and ISL6118” on page 10.

Typical Performance Curves

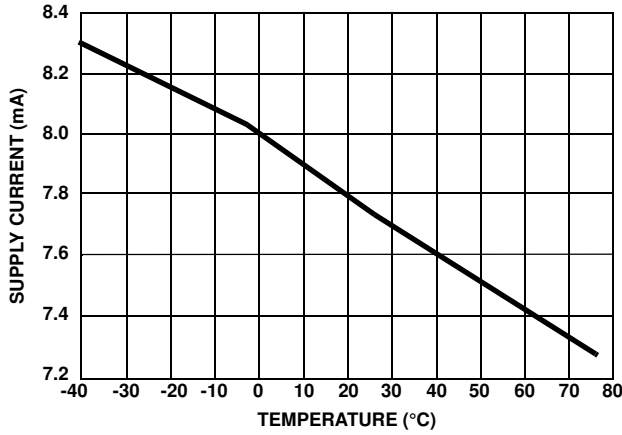

FIGURE 2. SUPPLY CURRENT

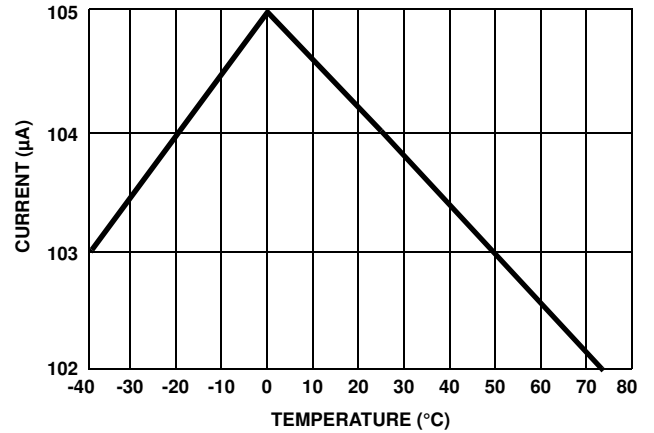

FIGURE 3. R_ILIM SOURCE CURRENT

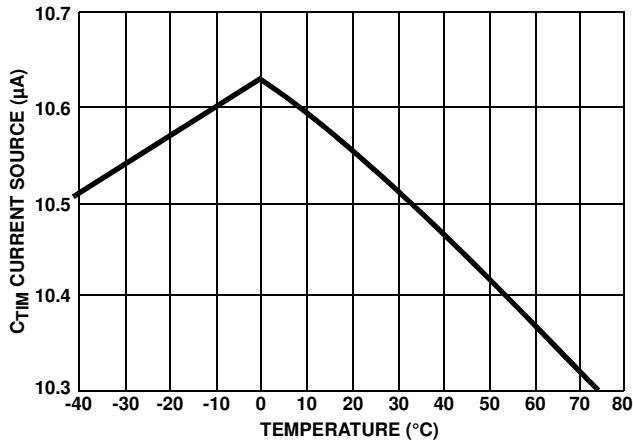

FIGURE 4. C_TIM CURRENT SOURCE

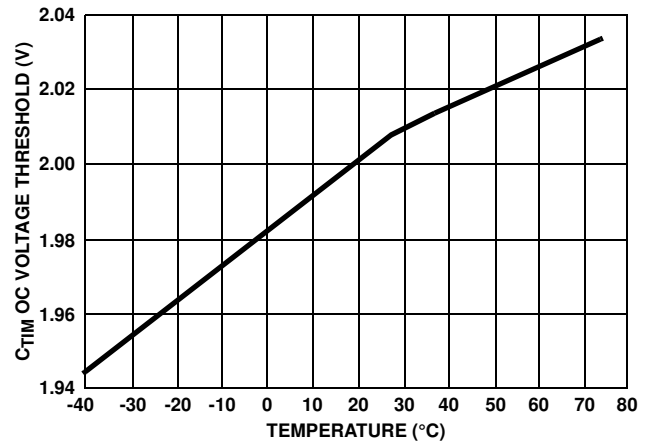

FIGURE 5. C_TIM OC VOLTAGE THRESHOLD

Typical Performance Curves (Continued)

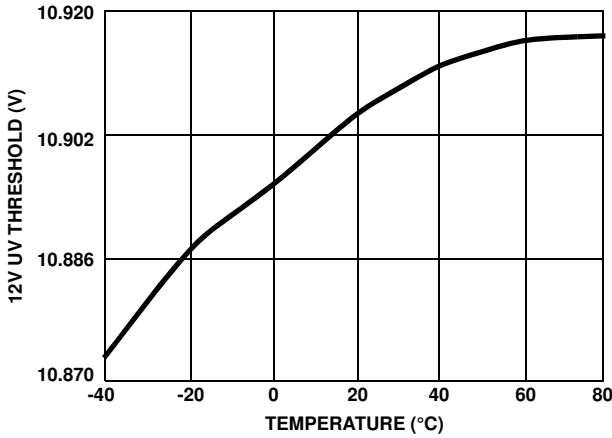

FIGURE 6. 12V UV THRESHOLD

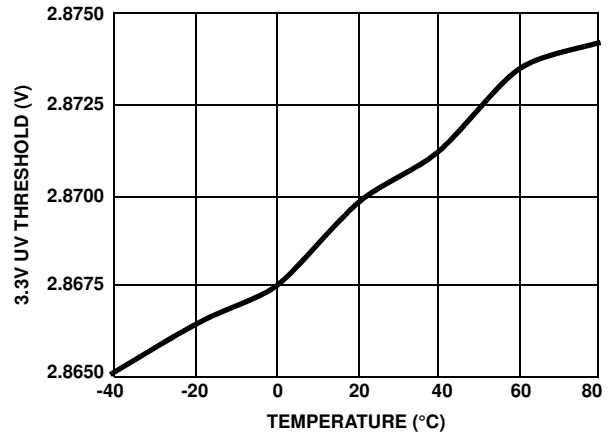

FIGURE 7. 3.3V UV THRESHOLD

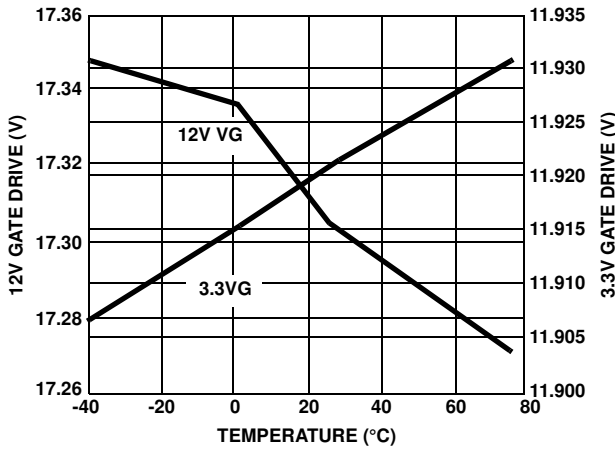

FIGURE 8. 12V, 3V GATE DRIVE

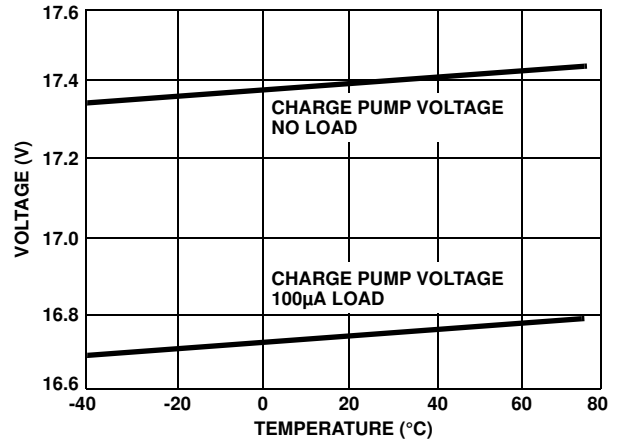

FIGURE 9. PUMP VOLTAGE

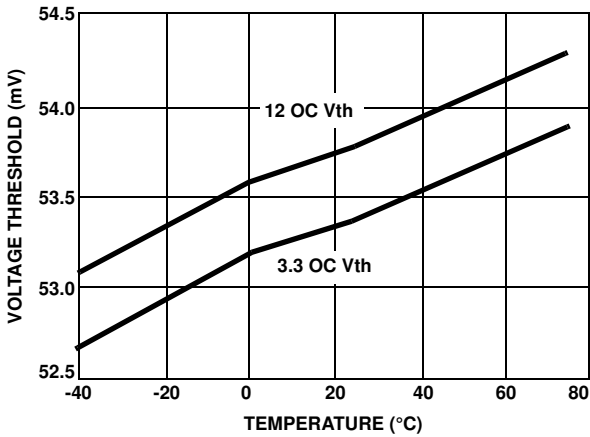

FIGURE 10. OC VOLTAGE THRESHOLD WITH $R_{LIM} = 5k\Omega$

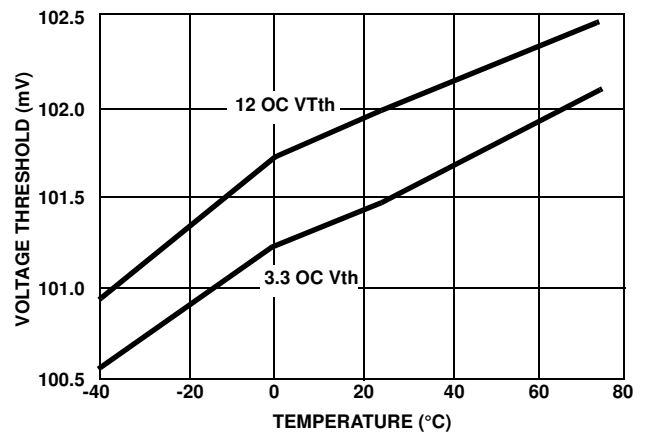

FIGURE 11. OC VOLTAGE THRESHOLD WITH $R_{LIM} = 10k\Omega$

Typical Performance Curves (Continued)

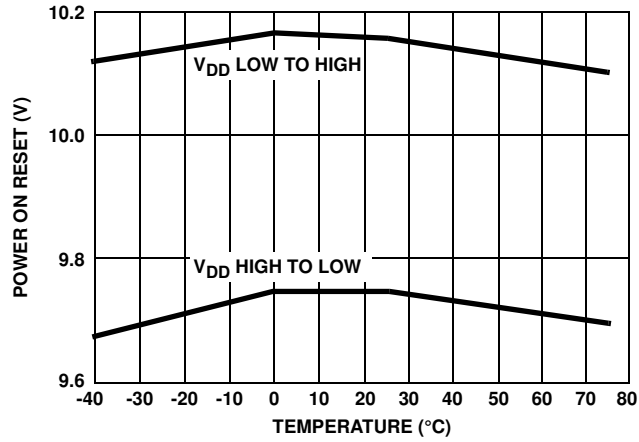
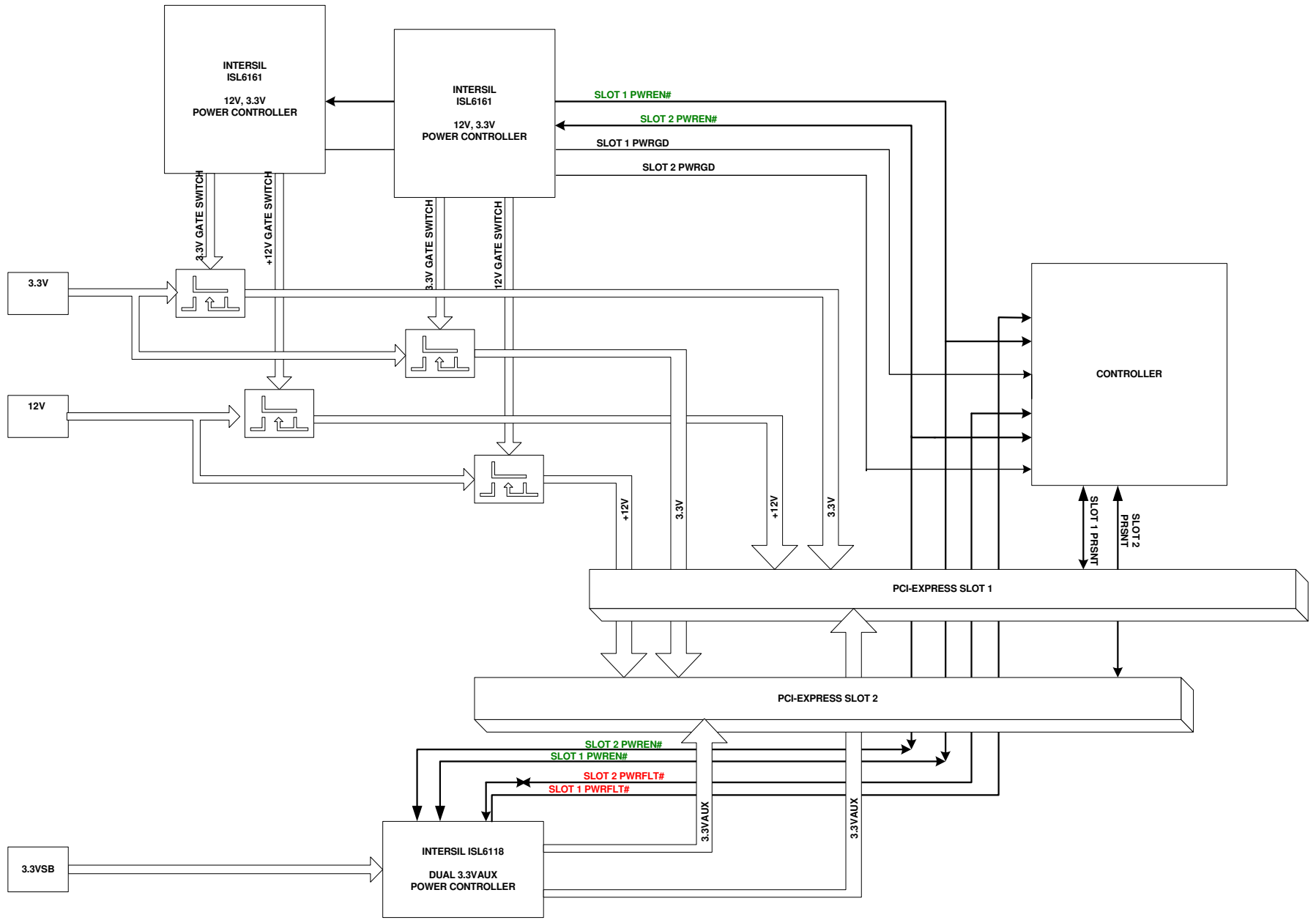
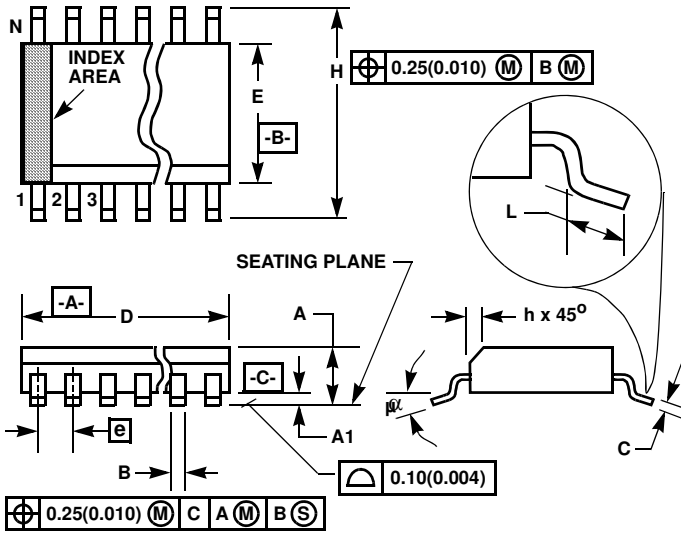

FIGURE 12. POWER-ON RESET VOLTAGE THRESHOLD

PCI-Express Implementation of ISL6161 and ISL6118



Small Outline Plastic Packages (SOIC)



**M14.15 (JEDEC MS-012-AB ISSUE C)
14 LEAD NARROW BODY SMALL OUTLINE PLASTIC PACKAGE**

SYMBOL	INCHES		MILLIMETERS		NOTES
	MIN	MAX	MIN	MAX	
A	0.0532	0.0688	1.35	1.75	-
A1	0.0040	0.0098	0.10	0.25	-
B	0.013	0.020	0.33	0.51	9
C	0.0075	0.0098	0.19	0.25	-
D	0.3367	0.3444	8.55	8.75	3
E	0.1497	0.1574	3.80	4.00	4
e	0.050 BSC		1.27 BSC		-
H	0.2284	0.2440	5.80	6.20	-
h	0.0099	0.0196	0.25	0.50	5
L	0.016	0.050	0.40	1.27	6
N	14		14		7
α	0°	8°	0°	8°	-

NOTES:

1. Symbols are defined in the "MO Series Symbol List" in Section 2.2 of Publication Number 95.
2. Dimensioning and tolerancing per ANSI Y14.5M-1982.
3. Dimension "D" does not include mold flash, protrusions or gate burrs. Mold flash, protrusion and gate burrs shall not exceed 0.15mm (0.006 inch) per side.
4. Dimension "E" does not include interlead flash or protrusions. Interlead flash and protrusions shall not exceed 0.25mm (0.010 inch) per side.
5. The chamfer on the body is optional. If it is not present, a visual index feature must be located within the crosshatched area.
6. "L" is the length of terminal for soldering to a substrate.
7. "N" is the number of terminal positions.
8. Terminal numbers are shown for reference only.
9. The lead width "B", as measured 0.36mm (0.014 inch) or greater above the seating plane, shall not exceed a maximum value of 0.61mm (0.024 inch).
10. Controlling dimension: MILLIMETER. Converted inch dimensions are not necessarily exact.

Rev. 0 12/93

All Intersil U.S. products are manufactured, assembled and tested utilizing ISO9000 quality systems. Intersil Corporation's quality certifications can be viewed at www.intersil.com/design/quality

Intersil products are sold by description only. Intersil Corporation reserves the right to make changes in circuit design, software and/or specifications at any time without notice. Accordingly, the reader is cautioned to verify that data sheets are current before placing orders. Information furnished by Intersil is believed to be accurate and reliable. However, no responsibility is assumed by Intersil or its subsidiaries for its use; nor for any infringements of patents or other rights of third parties which may result from its use. No license is granted by implication or otherwise under any patent or patent rights of Intersil or its subsidiaries.

For information regarding Intersil Corporation and its products, see www.intersil.com