

SPEAKER-1115-3.5-SC-COBRA-WP

The 11×15×3.5 mm COBRA-WP is an advanced miniature speaker of rectangular shape, specifically is a high end miniature speaker specifically designed for waterproof applications in portable consumer devices, such as music phones, smartphones or tablet computers where high quality sound is required. It features Knowles' advanced membrane technologies resulting in a state-of-the-art silicone membrane. This unique Knowles silicone membrane enables ultra-high excursion rates and superior robustness.

All materials used on the top surface of the speaker are tested to be water resistant. 100% leak measurement guarantees IPx8 waterproof compliance.

In addition to waterproof compliance this component provides the same performance as the standard COBRA speaker device (available under part number 2403 260 00091).



Features:

- IPx8 waterproof tested in 1.5m for 30min.
- Waterproof compliance 100% tested for each single speaker device
- 1000mW maximum power handling capacity even at high ambient temperature
- Unique Knowles silicone membrane providing ultra-high excursion for minimum THD, Q-factor and tumbling
- Pre-loaded springs for mechanical robustness and easy handling
- Multi-magnet system for improved sensitivity
- Fully-automated manufacturing
- 100% in-line measurement of specified acoustical and electrical parameters

Contents

1.	Theory of operation.....	3
2.	Mechanical Layout and Dimensions.....	4
2.1.	Main Dimensions.....	4
2.2.	PWB layout & electric polarity	5
2.3.	Magnetic polarity	5
2.4.	Spring force	6
2.5.	HNO3 test area	7
2.6.	Part marking/labeling.....	8
2.7.	Force on component	9
2.8.	Material list.....	10
2.9.	Water/gas tightness	10
3.	Electrical and Acoustical Specifications.....	11
3.1.	Frequency response	11
3.2.	Electro-acoustic parameters	12
3.3.	Power handling.....	12
3.4.	Measured parameters.....	13
3.5.	Measurement setup	13
3.6.	Measurement adapter	14
4.	Environmental Conditions.....	15
4.1.	Storage.....	15
4.2.	Transportation.....	15
4.3.	Functionality.....	15
5.	Environmental tests	16
5.1.	Qualification tests.....	16
5.2.	Reliability tests	16
5.3.	Sample size, sequence.....	16
5.4.	Period of Shelf-Life	16
5.5.	Testing procedures	16
6.	Related Documents	20
7.	Change History	21
8.	Disclaimer	21

2403 260 00132

1. Theory of operation

SPEAKER-1115-3.5-SC-COBRA-WP is an electrodynamic transducer, designed to translate electrical analog signals into acoustic waves. The input signal is fed into a coil which is exposed to a permanent magnetic field and where a membrane is attached to. Through the principle of the resulting electromagnetic force, the membrane is moved according to the contents of the input signal and thus emitting sound by the air shifted.

2403 260 00132

2. Mechanical Layout and Dimensions

2.1. Main Dimensions

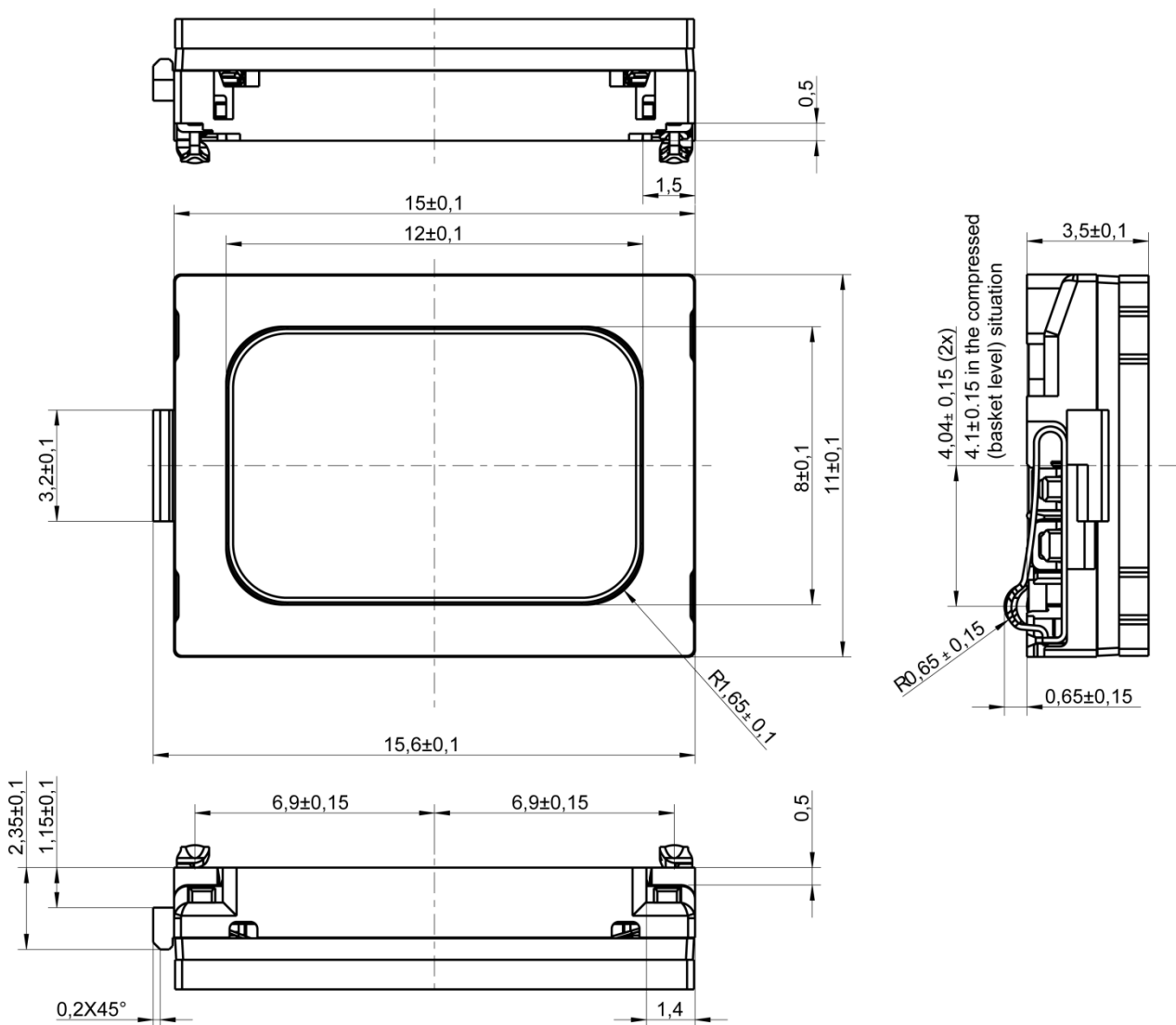

2403 260 00132

2.2. PWB layout & electric polarity

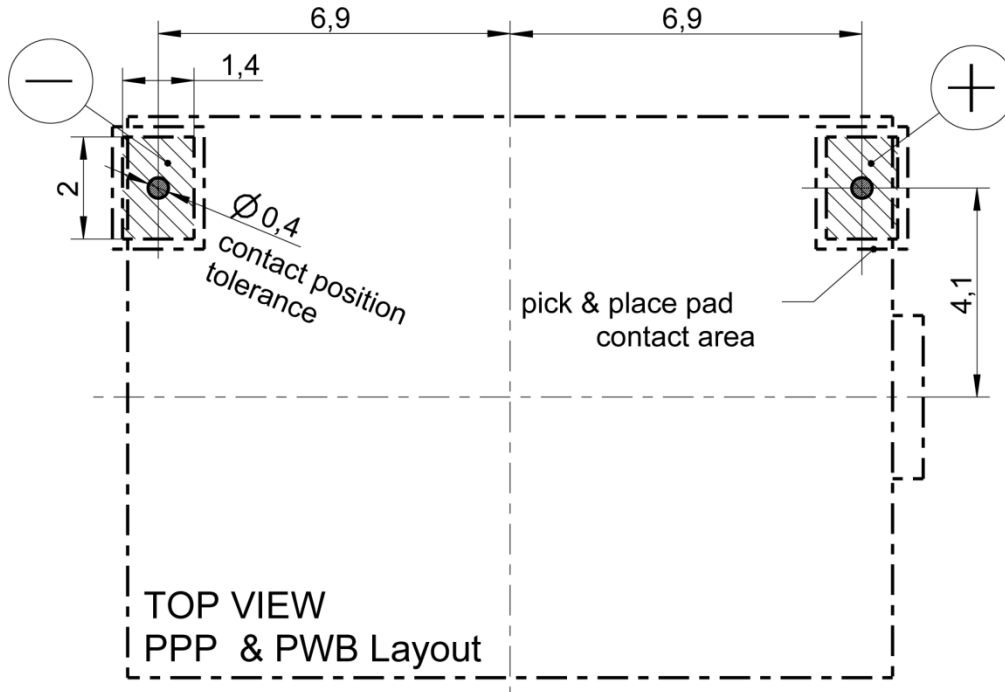

2.3. Magnetic polarity

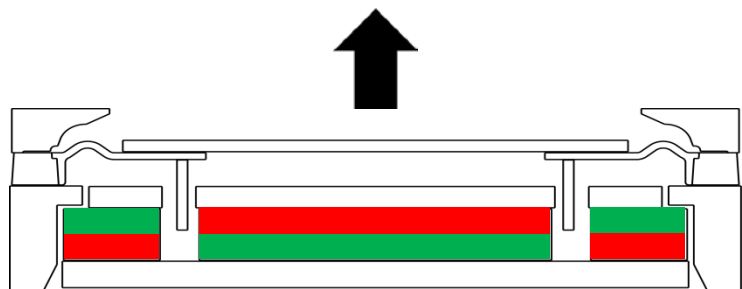
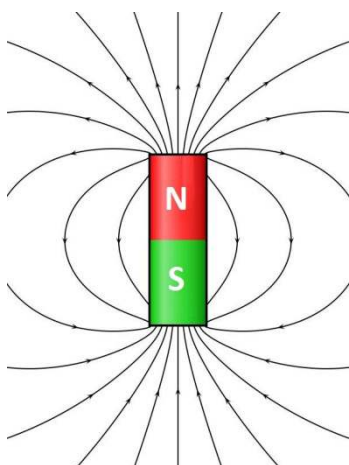

Positive voltage on pin +
 Moves the membrane in direction of arrow

2403 260 00132

2.4. Spring force

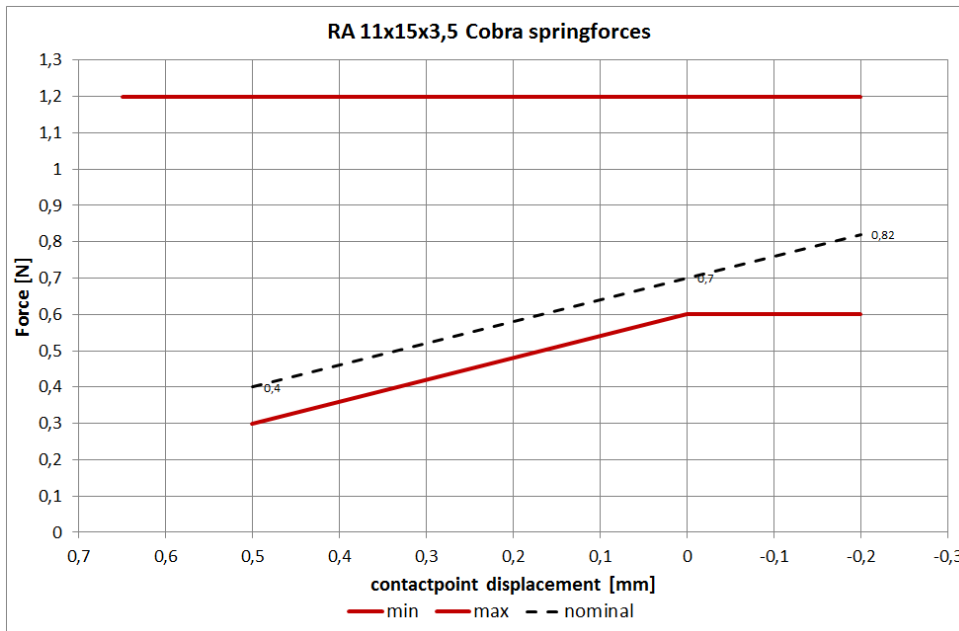
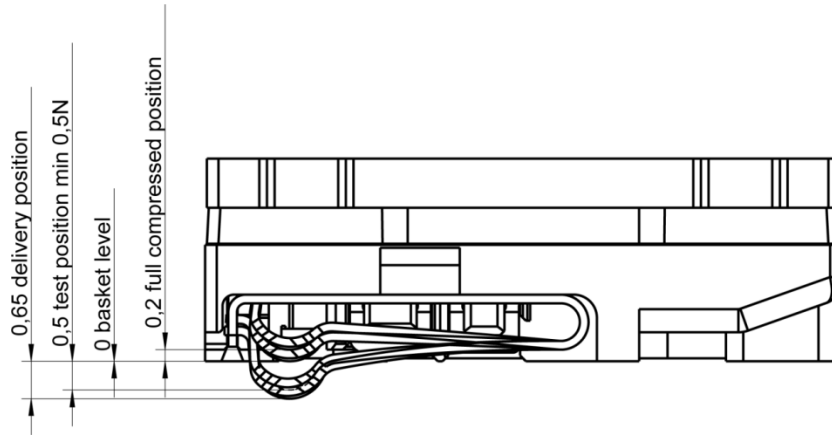

SPRING FORCE TABLE		
uncompressed (delivery position)	0.65 ±0.15 mm	0.0 N
Force at Start Working position (test position)	0.5 mm	min. 0.3 N
Force at Basket level	0.0 mm	min. 0.6 N
Force at PPP level (full compressed position)	-0.2 mm	max 1.2 N

2.4.1. Test method

- Test speed v = 10mm/min
- Load contact spring 2x to basket level (0.0mm)
- The min. contact spring force shall be measured at test position (0.5mm), second backwards stroke of diagram
- Load contact spring to full compressed (-0.2mm) and measure max. contact spring force

2403 260 00132

2.5. HNO3 test area

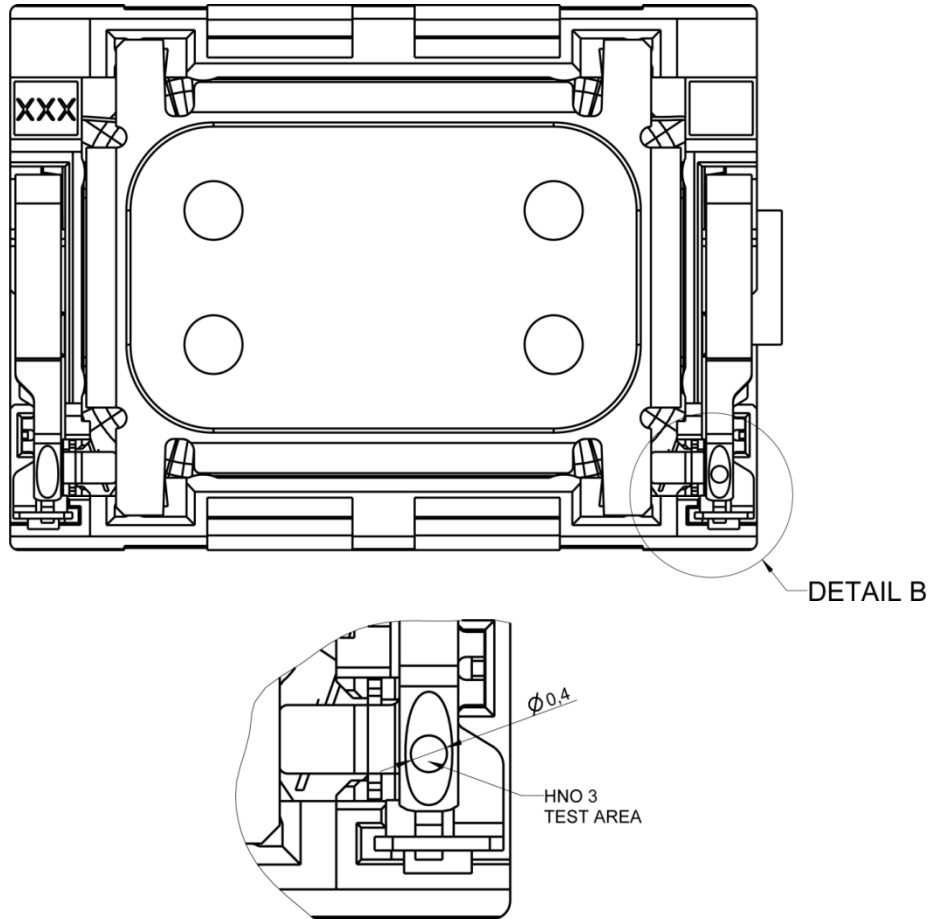

2403 260 00132

2.6. Part marking/labeling

The samples have a serial number on bottom (pot) side

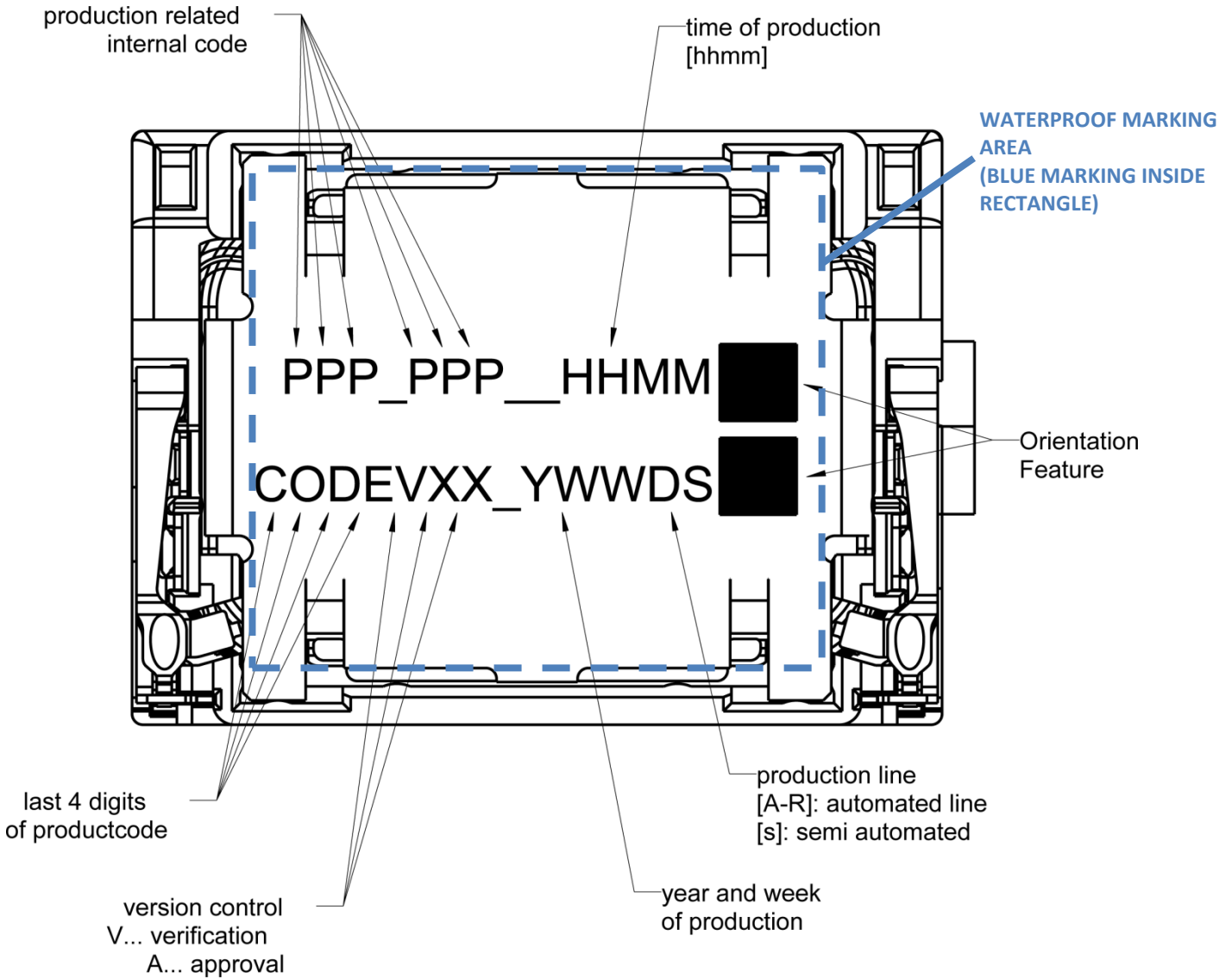

2403 260 00132

2.7. Force on component

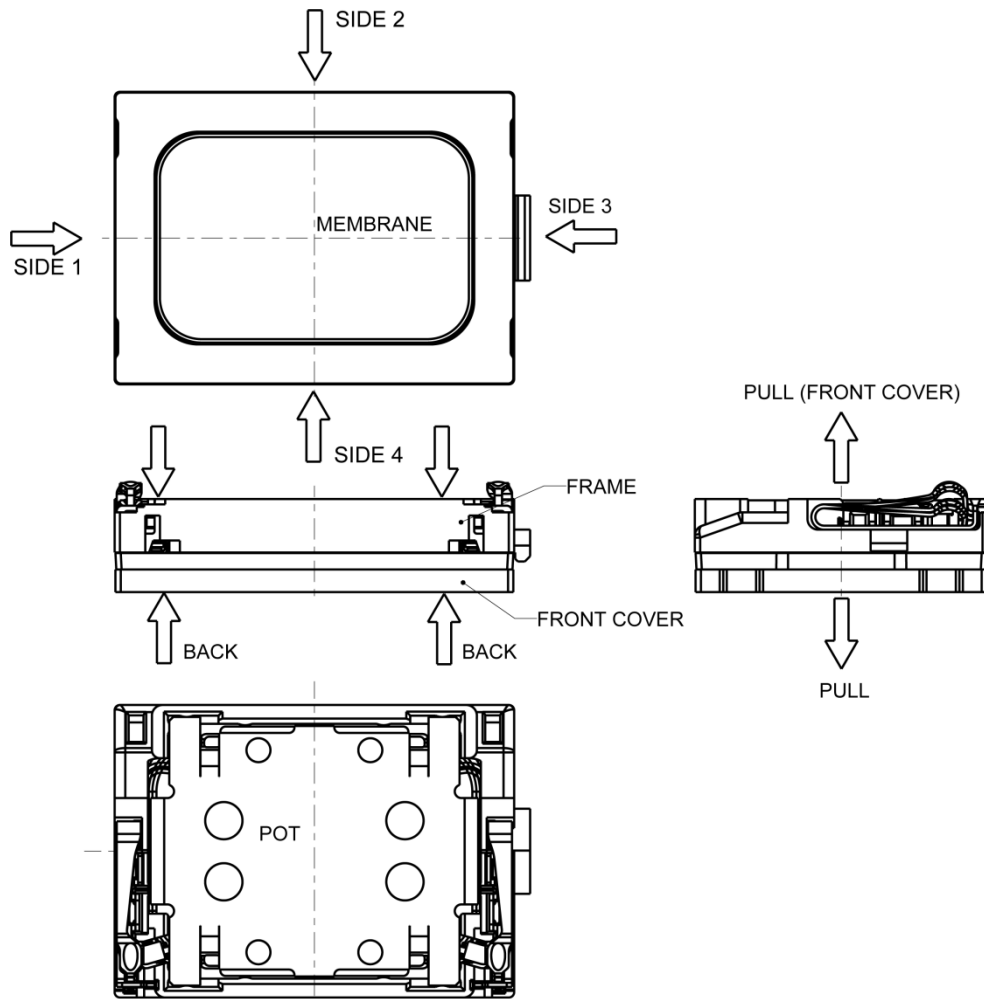

FORCES ON DIFFERENT STATE OF COMPONENT			
STATE	MIN.SURFACE OF PRESSURE [mm ²]	MAX. PERMANENT FORCE [N]	MAX. HANDLING FORCE [N]
FROM FRONT TO BACK	-	10	15
FROM SIDE 1 TO SIDE 3	3	10	15
FROM SIDE 2 TO SIDE 4	10	10	15
TO POT		10	15
TO MEMBRANE	-	0	0
PULL OFF FORCE	-	0	5

2403 260 00132

2.8. Material list

Material of basket:	Polycarbonate
Material of membrane:	Silicone
Material of membrane frame	Polybutylene Terephthalate (PBT)
Material of pot:	soft magnetic Iron
Material of magnet:	Nd Fe B
Material of contact	CrNi-Steel, gold plated
Material of cover:	Polycarbonate
Dimensions (in mm):	11 × 15 × 3.5
Mass:	1.5 g

2.9. Water/gas tightness

The products are 100% tested for leaks between cover and membrane.

Method: Differential pressure measurement
 Down force on cover: > 5N
 Allowed leakage: < 3cm³/minute.

2403 260 00132

3. Electrical and Acoustical Specifications

3.1. Frequency response

Typical frequency response measured on baffle according to chapter 3.5 and 3.6
(distance $d = 1\text{cm}$ calculated to 10cm , $p = 700\text{mW}$, 1cm^3)

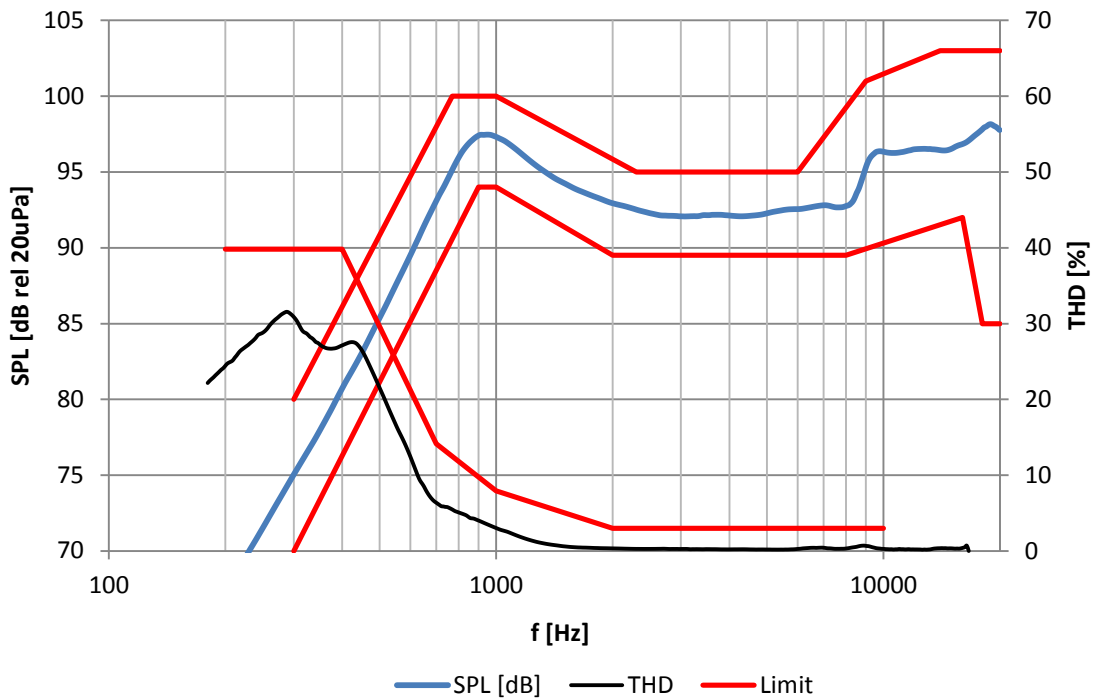

Tolerance window				
Frequency Response			THD	
f [Hz]	lower limit [dB SPL]	upper limit [dB SPL]	f [Hz]	upper limit [%]
300	70	80	200	40
770	-	100	400	40
900	94	-	700	14
1000	94	100	1000	8
2000	90	-	2000	3
2300	-	95	10000	3
6000	-	95		
8000	90	-		
9000	-	101		
14000	-	103		
16000	92	-		
18000	85	-		
20000	85	103		

2403 260 00132

3.2. Electro-acoustic parameters

Loudspeaker mounted in adapter acc. to 3.6 in setup acc. to 3.5.

1. Rated impedance	Z:	6Ω
2. Voice coil DC resistance	R:	5.4Ω±10%
3. Resonance frequency (measured @1cm ³ , 700mW)	f ₀ :	850Hz±7.5%
3.1 Typical resonance frequency (measured @open back, 0,5V) f ₀ :		500Hz
4. Maximum usable excursion (peak-peak)	x _{max} :	0.74mm _{p-p}
5. Measured characteristic sensitivity (measured at 1W in 1cm, calculated to 1m average from 2kHz to 6kHz, thermal compression included)		74±2dB
5.1. Measured characteristic sensitivity (at 1V in 10cm) average from 2kHz to 6kHz		87.2±2dB
6. THD		according chapter 3.1.
7. Rub & buzz		no audible R&B at max sine power

All acoustic measurements at 23±2°C

3.3. Power handling

Speaker mounted in 1cm³ test device (open front)

1. Max sine power	f ≥ 1kHz	1000mW
	f < 1kHz	700mW
(at 1cm ³ if no extra damping is provided)		
2. Max short term power	(70°, 1sec. ON / 60sec. OFF)	1200mW (RMS)
(pink noise, 2 nd order high pass filtered, -3dB at 1.2kHz, crest factor 2)		
3. Max continuous power	(70°, 500h)	1000mW (RMS)
(white noise, 2 nd order high pass filtered, -3dB at 100Hz, 2 nd order low pass filtered, -3dB at 8kHz, crest factor 2)		

3.4. Measured parameters

3.4.1. Sensitivity

SPL is expressed in dB rel 20 μ Pa, computed according to IEC 268-5. Measurement set up and parameters according chapter 3.5. This test is performed for 100% of products in the production line.

3.4.2. Frequency response

Frequency response is measured according test set up in chapter 3.5 data sheet and checked against the tolerance window defined in chapter 3.1. This Test is performed for 100% of products in the production line.

3.4.3. Total harmonic distortion (THD)

Is measured according IEC 268-5 (2nd to 5th harmonics) and test set up in chapter 3.5. This test is performed for 100% of products in the production line.

3.4.4. Rub & buzz

Rub & buzz will be measured in the Inline-measuring device with a sinusoidal sweep. Rub and buzz is defined as the maximum peak sound pressure in transmission range of the 5kHz high pass filter. This test is performed for 100% of products in the production line.

3.5. Measurement setup

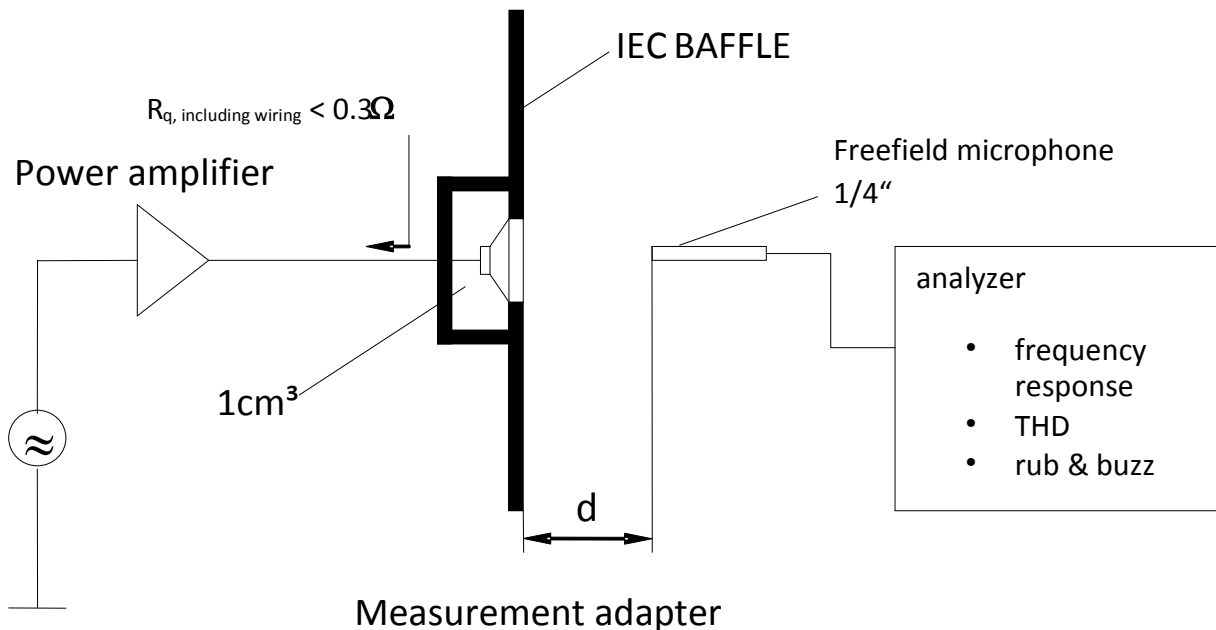

Measurement signal: Logarithmic sine sweep, 1.5s, 22kHz-180Hz

2403 260 00132

3.6. Measurement adapter

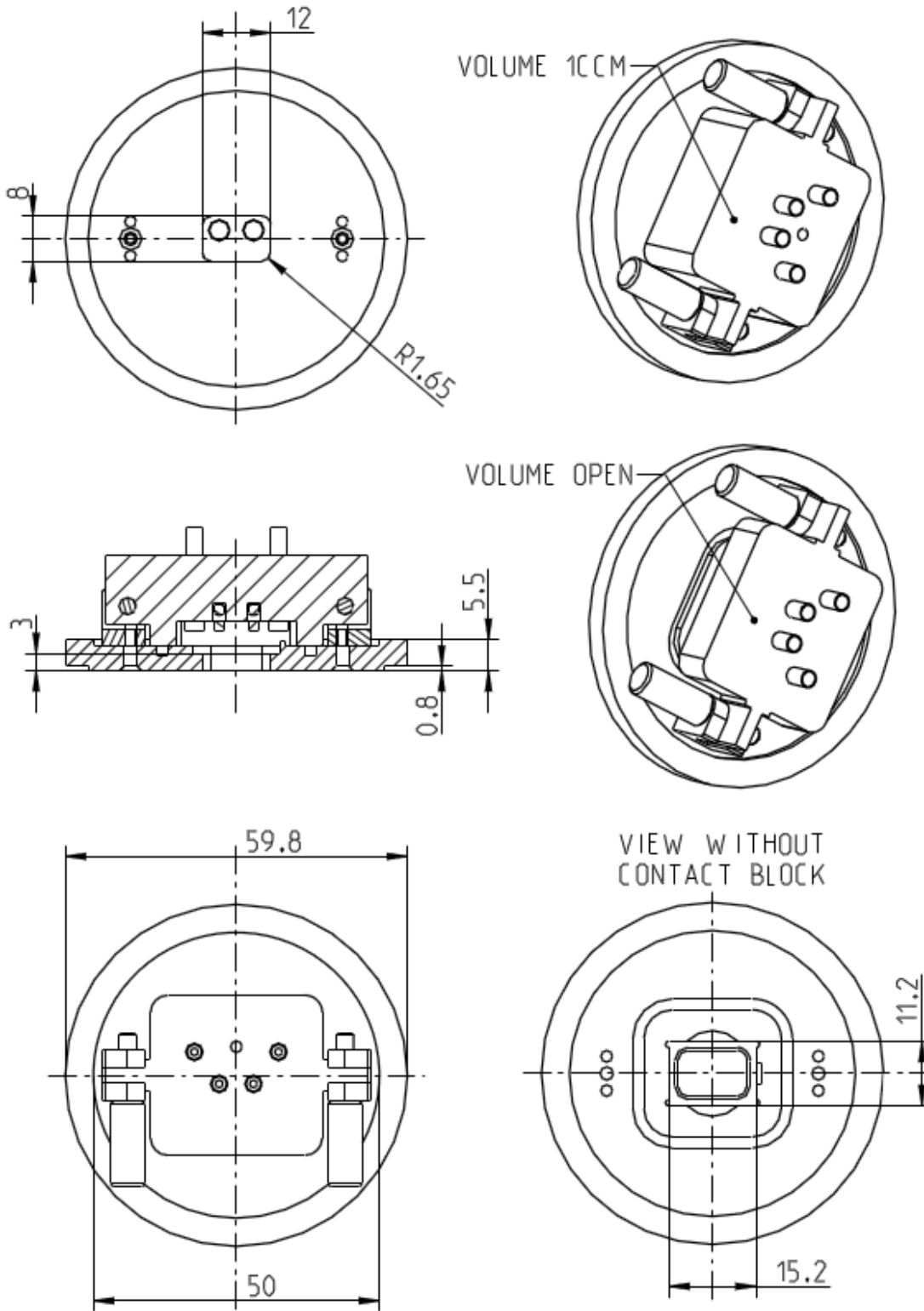

2403 260 00132

4. Environmental Conditions

4.1. Storage

The transducer fulfills the specified data after treatment according to the conditions of

ETS 300 019-2-1 Specification of environmental test: Storage
Test spec. T 1.2: Weather protected, not temperature controlled storage locations.

4.2. Transportation

The transducer fulfills the specified data after treatment according to the conditions of

ETS 300 019-2-2 Specification of environmental test: Transportation
Test Spec. T 2.3: Public Transportation

4.3. Functionality

The transducer fulfills the specified data after treatment according to the conditions of

ETS 300 019-2-5 Specification of environmental test: Ground vehicle installations
Test spec. T 5.1: Protected installation

ETS 300 019-2-7 Specification of environmental test: Portable and non-stationary use
Test spec. T 7.3E: Partly weather protected and non-weather protected locations.

5. Environmental tests

5.1. Qualification tests

According to our milestone plan (Product Creation Process), a complete qualification test will be done at design validation of products manufactured under serial conditions.

1x per year and product family a requalification takes place. The qualification process covers all tests described under 5.5 and a complete inspection.

5.2. Reliability tests

1x per month and product family samples are taken and submitted to tests described under 5.5.2

5.3. Sample size, sequence

Unless otherwise stated 20 arbitrary new samples will be used to perform each test for both, qualification and requalification test as described under 5.1 and 5.2.

5.4. Period of Shelf-Life

The period of shelf-life is 2 years.

5.5. Testing procedures

5.5.1. Storage tests

5.5.1.1. Cold storage test

Parameter	Test Method and Conditions	Duration	Evaluation Standard
Low Temperature Storage (Ref. EN 60068-2-1)	-40°C rel. humidity not controlled	168h	Measurements after 2 hours recovery time. All samples fully operable. All acoustical parameters according specification with tolerances increased by 50%.

5.5.1.2. Heat Storage Test

Parameter	Test Method and Conditions	Duration	Evaluation Standard
Dry Heat Storage (Ref. EN 60068-2-2)	+85°C rel. humidity not controlled	168h	Measurements after 2 hours recovery time. All samples fully operable. All acoustical parameters according specification with tolerances increased by 50%.

2403 260 00132

5.5.1.3. Temperature cycle test

Parameter	Test Method and Conditions	Duration	Evaluation Standard
Change of Temperature (Ref. EN 60068-2-14)	-40°C/+85°C Transition time <3 min. See Figure 5-1 below	5 cycles >2h for each temperature	Measurements after 2 hours recovery time. All samples fully operable. All acoustical parameters according specification with tolerances increased by 50%.

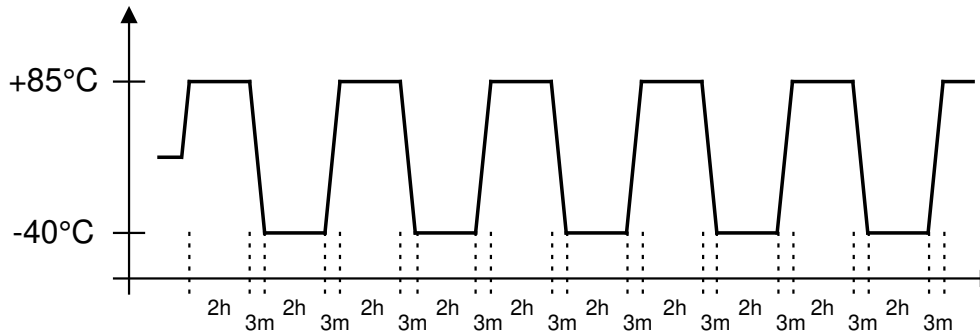

Figure 5-1: Temperature Cycle Test

5.5.1.4. Temperature/humidity cycle test

Parameter	Test Method and Conditions	Duration	Evaluation Standard
Damp heat, cyclic (Ref. IEC 60068-2-30)	+25°C/+55°C 90% to 95% RH. Temp. change time <3h See Figure 5-2 below <u>Caution:</u> no condensed water on products!	6 cycles. 12h at each temperature	Measurements after 2 hours recovery time. All samples fully operable. All acoustical parameters according specification with tolerances increased by 50%.

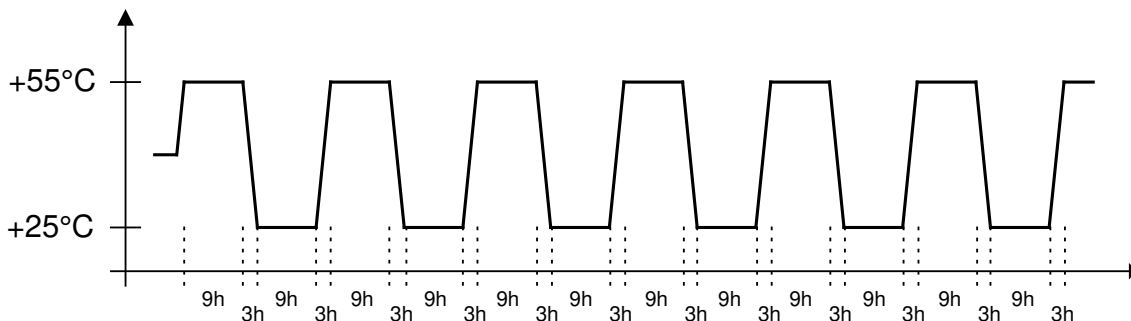

Figure 5-2: Temperature / Relative Humidity Cycle Test

5.5.2. Operating tests

5.5.2.1. Cold operation test

Parameter	Test Method and Conditions	Duration	Evaluation Standard
Cold Operation Test (Ref. EN 60068-2-1)	-20°C rel. humidity not controlled signal acc. Chapter 3.3	72h	Measurements after 2 hours recovery time. All samples fully operable. THD and resonance may be increased after test. All other acoustical parameters according specification with tolerances increased by 50%.

5.5.2.2. Heat operation test

Parameter	Test Method and Conditions	Duration	Evaluation Standard
Dry Heat Operation (Ref. EN 60068-2-2)	+70°C rel. humidity not controlled signal acc. Chapter 3.3	500h	Measurements after 2 hours recovery time. All samples fully operable. THD and resonance may be increased after test. All other acoustical parameters according specification with tolerances increased by 50%.

5.5.3. Salt mist test

Parameter	Test Method and Conditions	Duration	Evaluation Standard
Salt Mist (Ref. IEC60068-2-52, Kb / Severity 2)	The part must be subjected to 2 hours spray of 5% NaCl salt mist, at 35°C then be left at 40°C and 95% RH for 22h.	3 cycles	The samples shall be washed after the test with distilled water and dried at T < 50°C. Component may have reduced performance, but must still function properly. The allowable sensitivity difference shall not be greater than ±3dB from initial sensitivity.

5.5.4. Guided free fall test - protected product

Parameter	Test Method and Conditions	Conditions / Sample size	Evaluation Standard
Mechanical shock (Ref. IEC60068-2-32 Ed), Procedure 1	Speaker in drop test box or representative mechanics from a height of 1.5m onto concrete floor.	30 units Two drops on each side (2x6) One drop on each edge (1x12) Two drops on each corner (2x8) (40 drops in total)	Component may have reduced performance, but must still function properly. The allowable sensitivity difference shall not be greater than ± 3 dB from initial sensitivity.

5.5.5. Random free fall test (tumble test) – protected product

Parameter	Test Method and Conditions	Conditions / Sample size	Evaluation Standard
Impact durability (in a Tumble Tester) (Ref. IEC60068-2-32 Ed) (SPR a7.1.1)	Speaker in drop test box or representative mechanics. Random drops on steel base.	30 units 180 drops, 1m DUT power off	Component may have reduced performance, but must still function properly. The allowable sensitivity difference shall not be greater than ± 3 dB from initial sensitivity.

5.5.6. Resistance to electrostatic discharge

Parameter	Test Method and Conditions	Conditions / Sample size	Evaluation Standard
Resistance to ESD IEC61000-4-2 Level 4 (SPR c 2.5.1)	One pole is grounded and the ESD pulse is applied to the other pole. The speaker must be stressed first with one polarisation and then with the other polarisation. DUT must be discharged between each ESD exposure. Level 4: contact +/- 8kV, air +/- 15kV	10 exposures on each polarity / 5 units DUT Power off	All samples fully operable. All acoustical parameters according specification with tolerances increased by 50%.

5.5.7. **Water-resistant**

Parameter	Test Method and Conditions	Conditions / Sample size	Evaluation Standard
Water resistant acc. IPx8 (Ref. IEC60529)	The part must be immersed in 1.5m of water for 30min in an appropriate test adapter.	10 units 1.5m, 30min	No ingress of water through the products allowed. Measurements after samples are dry. All samples fully operable. The allowable change in sensitivity shall not be greater than 3dB. All other acoustical parameters according specification with tolerances increased by 50%.

6. **Related Documents**

- IEC 268-5** Sound System equipment
Part 5: Loudspeaker
- IEC 68-2** Environmental testing
- EN 60068-2** Environmental testing
- IEC 60529** Degrees of protection provided by enclosures (Ingress Protection Code)
- ISO 2859 - 1** Sampling procedures for inspection by attributes
Part 1: Sampling plans indexed by acceptable quality level (AQL) for lot-by-lot inspection
- ISO 3951** Sampling procedures and charts for inspection by variables for percent defectives.
- ETS 300 019-2-1** Specification of environmental test: Storage
Test spec. T 1.2: Weather protected, not temperature controlled storage locations
- ETS 300 019-2-2** Specification of environmental test: Transportation
Test spec. T 2.3: Public Transportation
- ETS 300 019-2-5** Specification of environmental test: Ground vehicle installations
Test spec. T 5.1: Protected installation
- ETS 300 019-2-7** Specification of environmental test: Portable and non-stationary use
Test spec. T 7.3E: Partly weather protected and non-weather protected locations



2403 260 00132

7. Change History

Status	Version	Date	ECR	Comment / Changes	Initials of owner
Release	A	06.08.13	4109	First Release	MS/GZ/CP

8. Disclaimer

Stresses above the Absolute Maximum Ratings may cause permanent damage to the device. These are stress ratings only. The device may not function when operated at these or any other conditions beyond those indicated under “Electrical and Acoustical Specifications”. Exposure beyond those indicated under “Electrical and Acoustical Specifications” for extended periods may affect device reliability.

This product is not qualified for use in automotive applications

Frequency range in telecom application:
300 Hz – 3.4 kHz

The information contained in this literature is based on our experience to date and is believed to be reliable and it is subject to change without notice. It is intended as a guide for use by persons having technical skill at their own discretion and risk. We do not guarantee favorable results or assume any liability in connection with its use. Dimensions contained herein are for reference purposes only. For specific dimensional requirements consult factory. This publication is not to be taken as a license to operate under, or recommendation to infringe any existing patents. This supersedes and voids all previous literature.