

CMOS Logic

■ GENERAL DESCRIPTION

XC74WL4053SR is 2-channel analog multiplexer / demultiplexer manufactured using silicon gate CMOS processes. The small supply current, which is one of the features of the CMOS logic, gives way to high speed operations which enables LS-TTL. With wave forming buffers connected internally, stabilized output can be achieved as the series offers high noise immunity. As the series is integrated into a mini molded, MSOP-8B package, high density mounting is possible.

■ APPLICATIONS

- Palmtops
- Digital equipment

■ FEATURES

- High Speed Operations** : tpd = 1.5ns (TYP.) (VCC=5V)
- Operating Voltage Range** : 2V ~ 5.5V
- Low ON Resistance** : RON = 12Ω (TYP.)
- Low Power Consumption** : 2 μA (MAX.)@Ta=25°C
- CMOS Logic 2-channel Analog Multiplexer/Demultiplexer**
- Small Package** : MSOP-8B

■ PIN CONFIGURATION

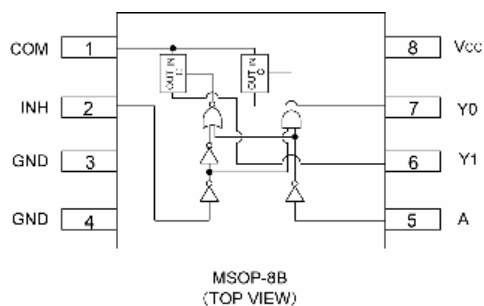

■ FUNCTIONS

CONTROL INPUT		ON CHANNEL
INH	A	
H	X	NONE
L	H	Y1
L	L	Y0

H=High level

L=Low level

X=Don't care

■ ABSOLUTE MAXIMUM RATINGS

Ta=-40°C~85°C

PARAMETER	SYMBOL	RATINGS	UNITS
Supply Voltage	VCC	-0.5~+6.0	V
Control Input Voltage	VCONT	-0.5~+6.0	V
Switch Input/Output Voltage	V _{i/o}	-0.5~VCC+0.5	V
Control Input Diode Current	I _{IK}	-20	mA
Switch Output Diode Current	I _{OK}	±20	mA
Switch Input/Output Current	I _{i/o}	±25	mA
VCC,GND Current	I _{CC} ,I _{GND}	±50	mA
Power Dissipation (Ta = 25°C)	Pd	300	mW
Storage Temperature Range	Tstg	-65~+150	°C

Note: Voltage is all ground standardized

RECOMMENDED OPERATING CONDITIONS

PARAMETER	SYMBOL	CONDITIONS	UNITS
Supply Voltage	V _{CC}	2~5.5	V
Control Input Voltage	V _{CONT}	0~5.5	V
Switch Input/Output Voltage	V _{io}	0~V _{CC}	V
Operating Temperature Range	T _{opr}	-40~+85	°C
Input Rise and Fall Time	t _{r,tf}	0~200 (V _{CC} =3.3V)	ns
		0~100 (V _{CC} =5V)	

DC ELECTRICAL CHARACTERISTICS

PARAMETER	SYMBOL	V _{CC} (V)	CONDITIONS	T _a =25°C			T _a =-40°C~85°C		UNITS
				MIN.	TYP.	MAX.	MIN.	MAX.	
High Level Control Input Voltage	V _{IH}	2.0		1.50	—	—	1.50	—	V
		3.0		2.10	—	—	2.10	—	
		5.5		3.85	—	—	3.85	—	
Low Level Control Input Voltage	V _{IL}	2.0		—	—	0.50	—	0.50	V
		3.0		—	—	0.90	—	0.90	
		5.5		—	—	1.65	—	1.65	
Peak ON Resistance	R _{ONmax}	2.0	V _{INH} =V _{IL}	—	130	350	—	550	Ω
		3.0	V _{COM} =0~V _{CC}	—	22	50	—	65	
		4.5	I _{COM} =1mA	—	12	25	—	35	
ON Resistance	R _{ON(1)}	2.0	V _{INH} =V _{IL}	—	23	50	—	65	Ω
		3.0	V _{COM} =GND OR V _{CC}	—	14	30	—	40	
		4.5	I _{COM} =1mA	—	10	20	—	25	
Switch ON Resistance Differential	ΔR _{ON}	2.0	V _{INH} =V _{IL}	—	13	35	—	55	Ω
		3.0	V _{COM} =0~V _{CC}	—	3	6	—	8	
		4.5	I _{COM} =1mA	—	2	4	—	6	
Power Off Leak Current	I _{S(OFF)}	5.5	V _{INH} =V _{IH} , V _{OM} =V _{CC} , V _Y =GND	—	—	±0.1	—	±0.1	μA
Power On Leak Current	I _{S(ON)}	5.5	V _{INH} =V _{IL} , V _{COM} =V _{CC} , or GND	—	—	±0.1	—	±0.1	μA
Control Input Current	I _{INH}	0~5.5	V _{COM} =V _{CC} or GND	—	—	±0.1	—	±0.1	μA
Static Supply Current	I _{CC}	5.5	V _{COM} =V _{CC} or GND	—	—	2.0	—	20.2	μA

SWITCHING ELECTRICAL CHARACTERISTICS

(tr=tf=3ns)

PARAMETER	SYMBOL	CONDITIONS		Ta=25°C			Ta=-40°C~85°C		UNITS	
		CL	VCC(V)	MIN.	TYP.	MAX.	MIN.	MAX.		
Delay Time	tPLH tPHL	15pF	2.0	RL=1kΩ	—	2.5	12.0	—	15.0	ns
			3.3		—	2.0	4.0	—	5.5	
			5.0		—	1.5	3.0	—	4.0	
		50pF	2.0		—	4.0	20.0	—	23	ns
			3.3		—	3.0	6.0	—	8.0	
			5.0		—	2.0	5.0	—	6.0	
Output Enable Time	tzL tzH	15pF	2.0	RL=1kΩ	—	8.5	45.0	—	60.0	ns
			3.3		—	4.5	9.0	—	11.0	
			5.0		—	3.5	7.5	—	9.0	
		50pF	2.0		—	9.0	50.0	—	65.0	ns
			3.3		—	5.0	10.0	—	12.0	
			5.0		—	4.0	8.5	—	10.0	
Output Disable Time	tlZ thZ	15pF	2.0	RL=1kΩ	—	9.0	45.0	—	55.0	ns
			3.3		—	7.0	17.0	—	20.0	
			5.0		—	6.0	14.0	—	18.0	
		50pF	2.0		—	12	60.0	—	75.0	ns
			3.3		—	10	23.0	—	27.0	
			5.0		—	8.0	20.0	—	25.0	
Sine Wave Distortion Rate		50pF	3.0	RL=1kΩ fCOM=1kHz	—	0.05	—	—	—	%
-3dB Band Width		50pF	3.0	RL=600kΩ $20\log_{10}\frac{V_Y}{V_{COM}}=-3dB$	—	200	—	—	—	MHz
Feed Through (Switch off)		50pF	3.0	RL=600kΩ	—	-60	—	—	—	dB
Cross Talk (Control Switches)		50pF	2.0	RL=600kΩ fINH=1MHz	—	60	—	—	—	mV
			3.0		—	100	—	—	—	
			4.5		—	150	—	—	—	
Cross Talk (Between Switches)		50pF	2.0	RL=600kΩ fCOM=1kHz	—	-60	—	—	—	dB
			3.0		—	-60	—	—	—	
			4.5		—	-60	—	—	—	
Control Input Capacitance	CINH	—	—		—	5	10	—	10	pF
Switch Input/Output Capacitance	COM/Y	—	—		—	6	—	—	—	pF
Feed Through Capacitance	COM/Y	—	—		—	0.5	—	—	—	pF
Power Dissipation Capacitance	Cpd	—	—		—	13	—	—	—	pF

ON RESISTANCE

Test Circuit

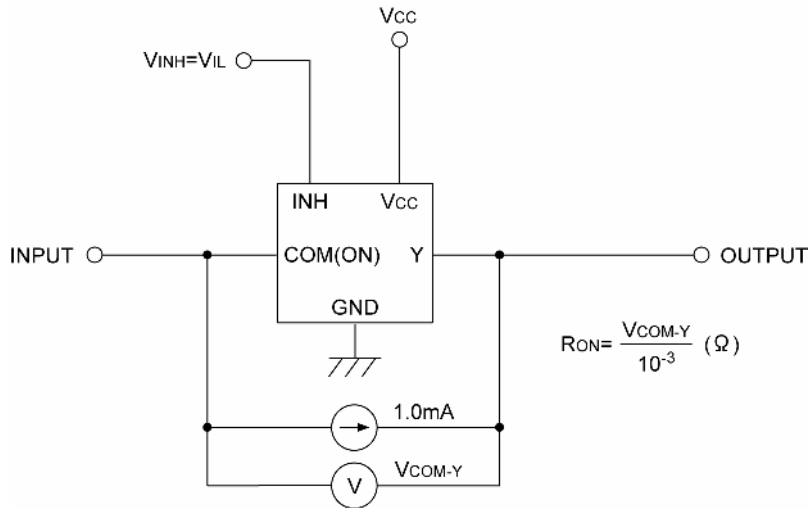

Input Voltage Dependencies of ON Resistance

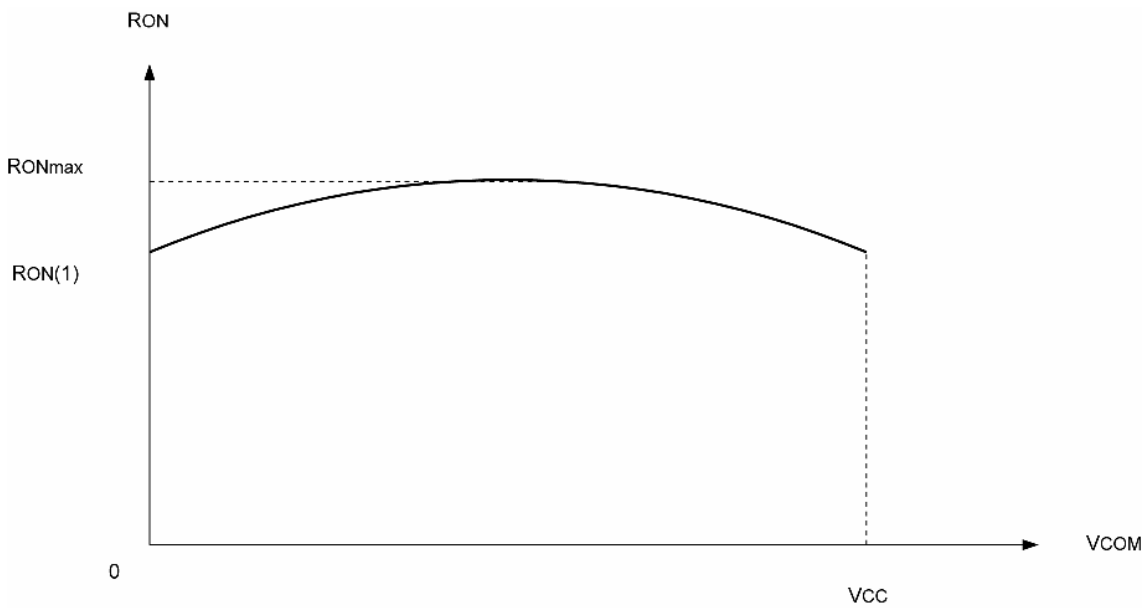

■ POWER OFF LEAK CURRENT

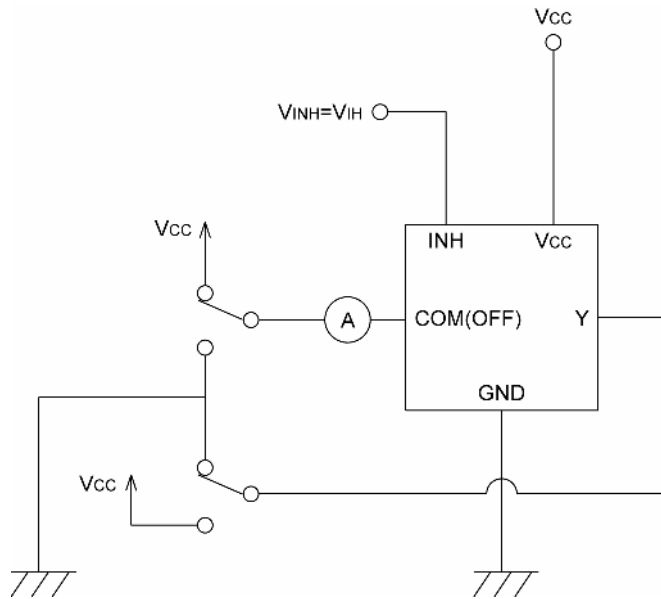

■ POWER ON LEAK CURRENT

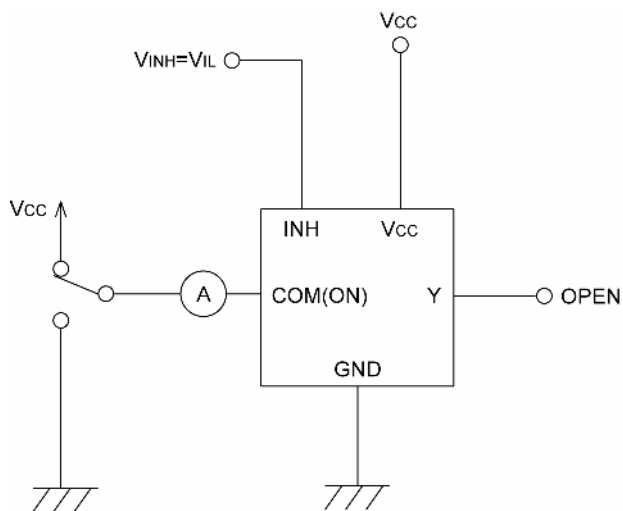

XC74WL4053SR

■ DELAY TIME

● Test Circuit

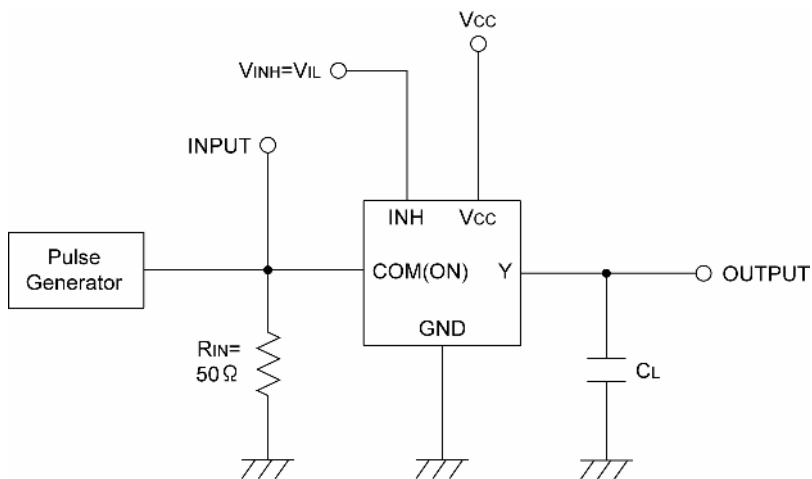

● Waveform

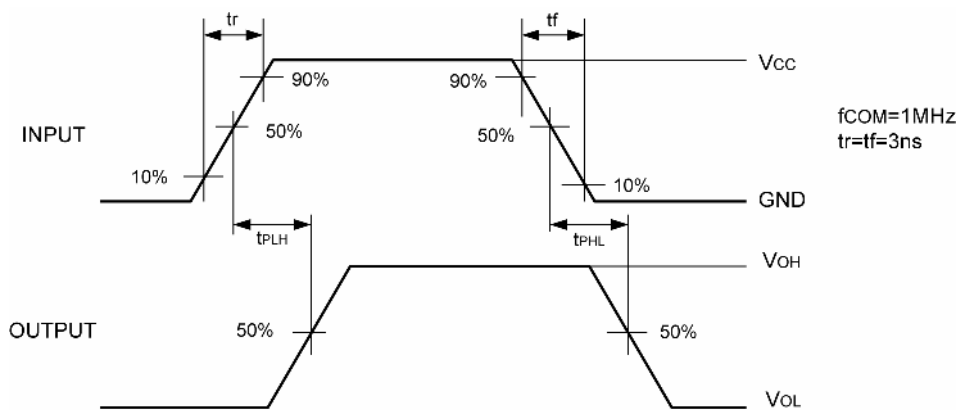

OUTPUT ENABLE TIME, OUTPUT DISABLE TIME

Test Circuit

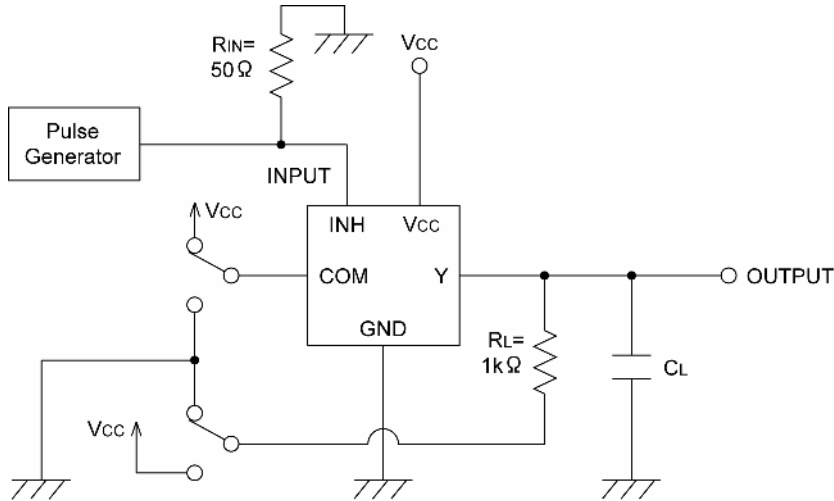

Waveform

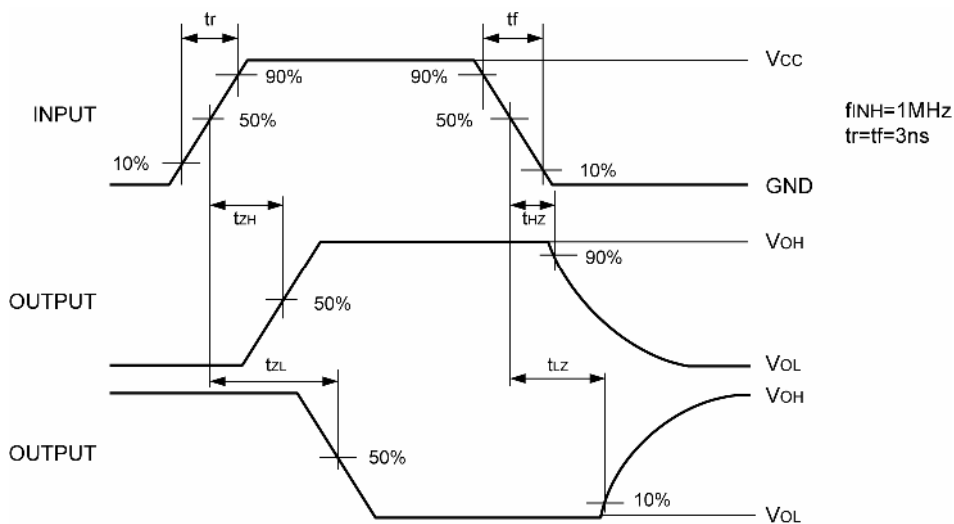

■ SINE WAVE DISTORTION RATE

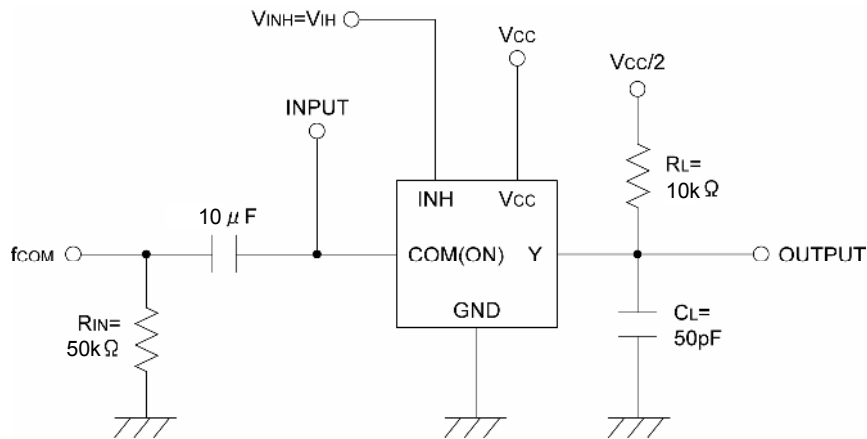

* f_{COM} by sine wave ($f=1\text{MHz}$)

■ -3dB BAND WIDTH

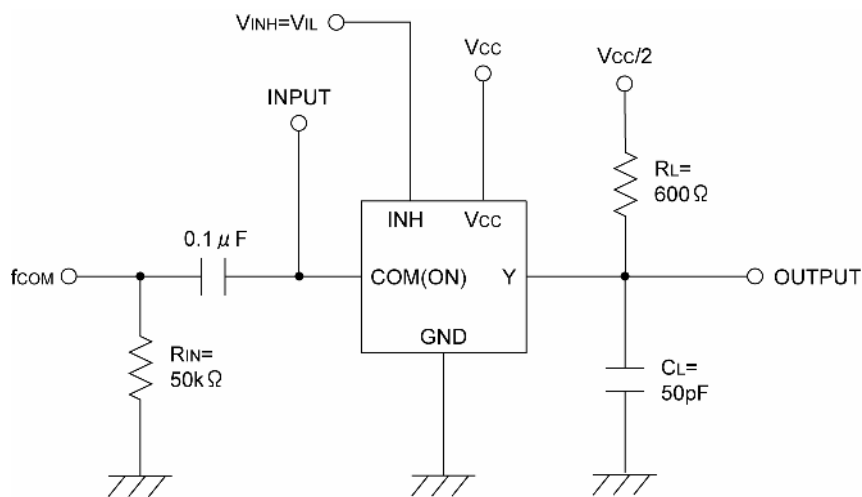

* f_{COM} by sine wave ($V_{COM}=V_{CC}/10[V_{p-p}]$)

■ FEED THROUGH TEST CIRCUIT

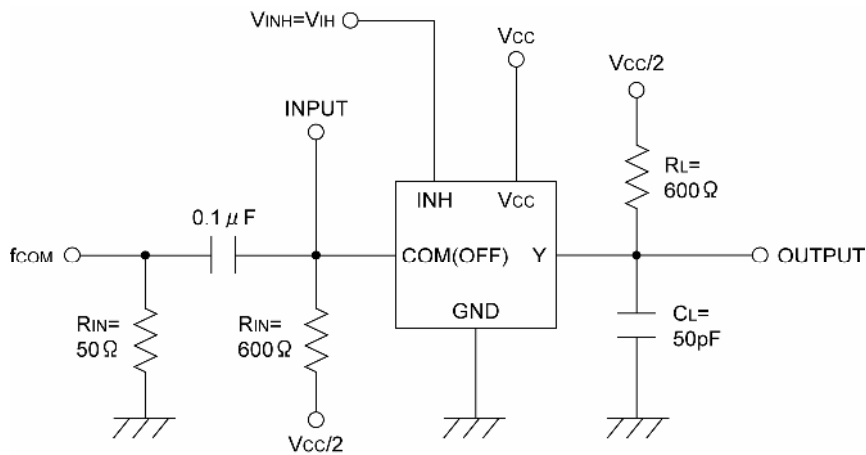

* fCOM by sine wave (f=1MHz)

■ CROSS TALK (CONTROL INPUT → SWITCH OUTPUT)

● Test Circuit

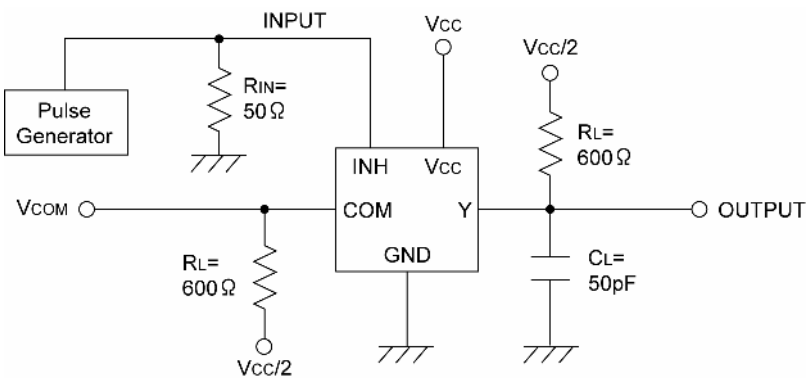

● Waveform

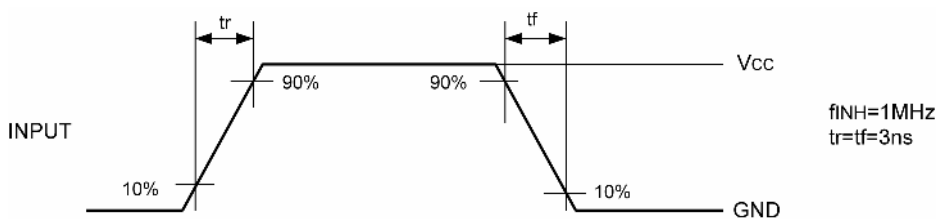

XC74WL4053SR

■ CROSS TALK (BETWEEN SWITCHES)

● Test Circuit

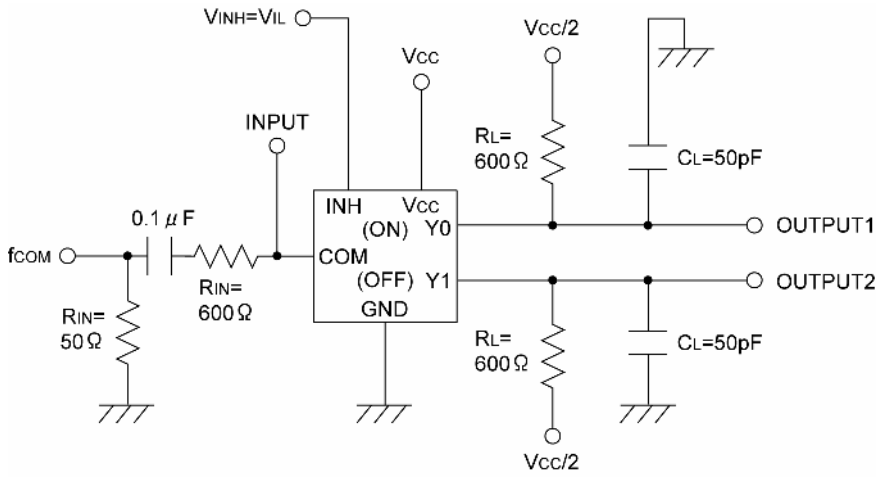

● Waveform

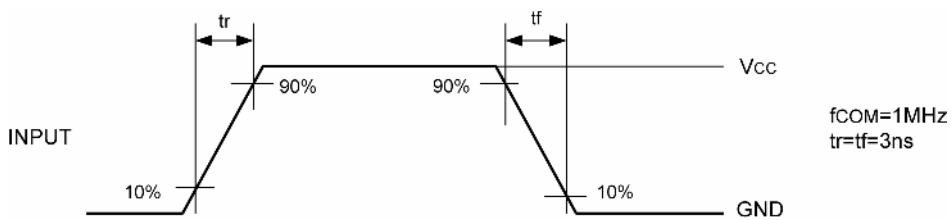

1. The products and product specifications contained herein are subject to change without notice to improve performance characteristics. Consult us, or our representatives before use, to confirm that the information in this catalog is up to date.
2. We assume no responsibility for any infringement of patents, patent rights, or other rights arising from the use of any information and circuitry in this catalog.
3. Please ensure suitable shipping controls (including fail-safe designs and aging protection) are in force for equipment employing products listed in this catalog.
4. The products in this catalog are not developed, designed, or approved for use with such equipment whose failure of malfunction can be reasonably expected to directly endanger the life of, or cause significant injury to, the user.
(e.g. Atomic energy; aerospace; transport; combustion and associated safety equipment thereof.)
5. Please use the products listed in this catalog within the specified ranges.
Should you wish to use the products under conditions exceeding the specifications, please consult us or our representatives.
6. We assume no responsibility for damage or loss due to abnormal use.
7. All rights reserved. No part of this catalog may be copied or reproduced without the prior permission of Torex Semiconductor Ltd.

TOREX SEMICONDUCTOR LTD.