

NOTES:

- HOUSING MATERIAL: LIQUID CRYSTAL POLYMER, GLASS FILLED, UL 94V-0, BLACK
CONTACT MATERIAL: HIGH PERFORMANCE COPPER ALLOY
SOLDER NAIL MATL: STAINLESS STEEL
SOLDER CHARGE MATL: 63% TIN, 37% LEAD
- FINISH:
CONTACT AREA: 0.76 MICROMETER (30 MICROINCH) MINIMUM GOLD
TAIL AREA: 2.54 MICROMETER (100 MICROINCH) MINIMUM 90/10 TIN-LEAD
ENTIRE TERMINAL: NICKEL UNDERPLATE
- PRODUCT SPEC: PS-45802-001
- COSMETIC SPEC: PS-45499-002 CLASS B
- PACKAGING SPEC: PK-45830-001 MOLEX STANDARD TRAYS
- DATUM -C- IS THE CENTERLINE OF THE 2 END SLOTS. END SLOT CENTERLINES ARE ESTABLISHED USING 2 MEASUREMENTS FOR EACH SLOT TAKEN 7.28 EITHER SIDE OF DATUM -B-.
- THERE ARE 13 CIRCUITS PER ROW

DETAIL 1
SCALE 8:1

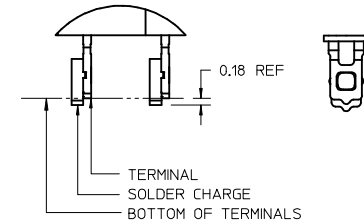

INITIAL RELEASE EC NO: UCP2016-2554 DRWN: TIBARRA 2015/12/21 CHKD: BBARKER 2015/12/21 APPR: TIBARRA 2016/01/27	QUALITY SYMBOLS ▽=0 ▽=0 ▽=0	GENERAL TOLERANCES (UNLESS SPECIFIED)		DIMENSION STYLE MM ONLY		SCALE 2:1	DESIGN UNITS METRIC	THIRD ANGLE PROJECTION			
			mm	INCH	DRAWN BY TIBARRA	DATE 2015/12/21	HIGH DENSITY MEZZANINE PLUG ASSEMBLY TIN-LEAD TAILS, CHARGES				
		4 PLACES	± ---	± ---	CHECKED BY BBARKER	DATE 2015/12/21					
		3 PLACES	± 0.05	± ---	APPROVED BY TIBARRA		DATE 2016/01/27	molex			
2 PLACES	± 0.15	± ---	MATERIAL NO. SEE TABLE		DOCUMENT NO. RSD-45830-0001	SHEET NO. 1 OF 2					
1 PLACE	± 0.3	± ---	ANGULAR ±1/2° DRAFT WHERE APPLICABLE MUST REMAIN WITHIN DIMENSIONS							THIS DRAWING CONTAINS INFORMATION THAT IS PROPRIETARY TO MOLEX INCORPORATED AND SHOULD NOT BE USED WITHOUT WRITTEN PERMISSION	
0 PLACE	±	±	SIZE B								

TIN / LEAD PARTS
LEAD CODE = "0"

STACK HEIGHT:	8mm	9mm	10mm	11mm	12mm	13mm	14mm	15mm	17mm	18mm	
DIM B	10.41	11.41	12.41	13.41	14.41	15.41	16.41	17.41	19.41	20.41	
DIM C	8.80	9.80	10.80	11.80	12.80	13.80	14.80	15.80	17.80	18.80	
ROWS	DIM A	DIM D	MATERIAL NO	MATERIAL NO	MATERIAL NO	MATERIAL NO	MATERIAL NO	MATERIAL NO	MATERIAL NO	MATERIAL NO	MATERIAL NO
7	12.00	30.06									
9	16.00	34.06									
11	20.00	38.06			45830-2111						
13	24.00	42.06									
15	28.00	46.06									
17	32.00	50.06									
19	36.00	54.06									
21	40.00	58.06									
23	44.00	62.06									
25	48.00	66.06									
27	52.00	70.06									

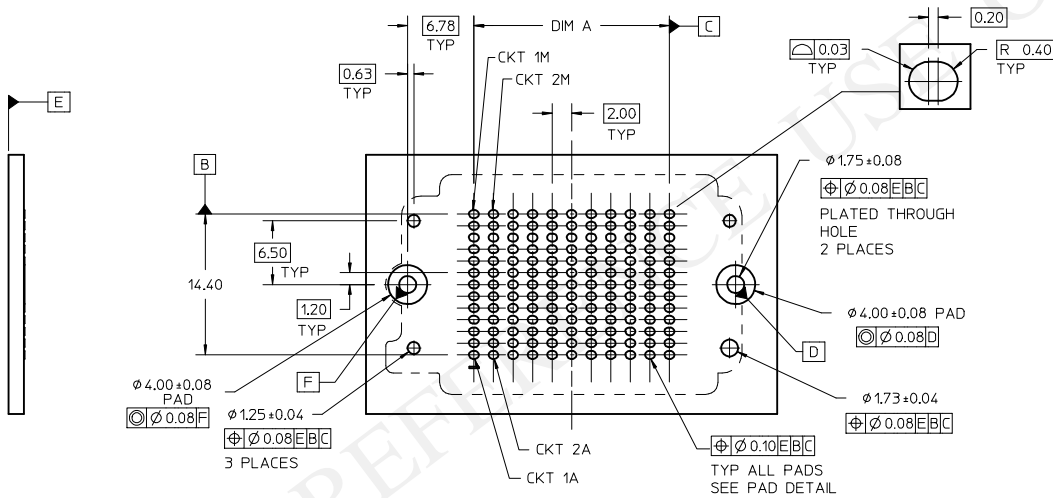
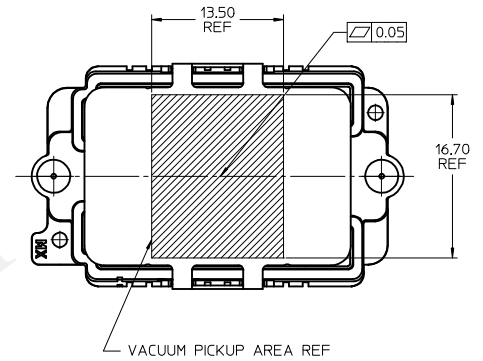

RECOMMENDED PCB LAYOUT: COMPONENT SIDE
PCB THICKNESS: NA

<p>SEE SHEET 1</p> <p>EC NO: UCP2016-2554</p> <p>DRWN: TIBARRA 2015/12/21</p> <p>CHKD: BBARKER 2015/12/21</p> <p>APPR: TIBARRA 2016/01/27</p>	<p>QUALITY SYMBOLS</p> <p>$\nabla = 0$</p> <p>$\nabla = 0$</p> <p>$\nabla = 0$</p>	GENERAL TOLERANCES (UNLESS SPECIFIED)		DIMENSION STYLE		SCALE	DESIGN UNITS	THIRD ANGLE PROJECTION		
				MM ONLY		2:1	METRIC			
		mm	INCH	DRAWN BY	DATE	TITLE				
		4 PLACES ± ---	± ---	TIBARRA	2015/12/21	HIGH DENSITY MEZZANINE PLUG ASSEMBLY TIN-LEAD TAILS, CHARGES				
3 PLACES ± 0.05	± ---	CHECKED BY	DATE							
2 PLACES ± 0.15	± ---	BBARKER	2015/12/21	<p>molex</p> <p>MATERIAL NO. SEE TABLE</p> <p>DOCUMENT NO. RSD-45830-0001</p>						
1 PLACE ± 0.3	± ---	APPROVED BY	DATE							
0 PLACE ±	±	TIBARRA	2016/01/27	ANGULAR ±1/2°		DRAFT WHERE APPLICABLE		MUST REMAIN WITHIN DIMENSIONS		
		SIZE B		THIS DRAWING CONTAINS INFORMATION THAT IS PROPRIETARY TO MOLEX INCORPORATED AND SHOULD NOT BE USED WITHOUT WRITTEN PERMISSION						

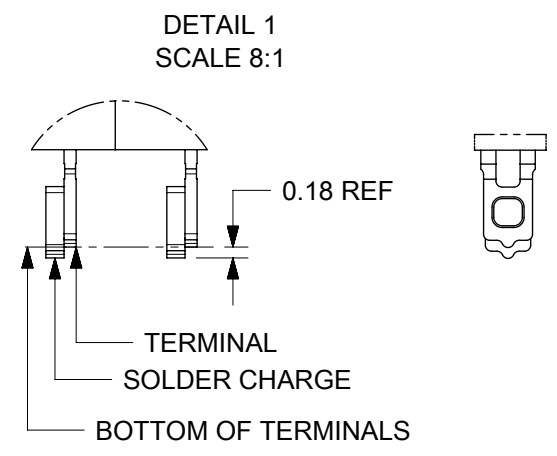
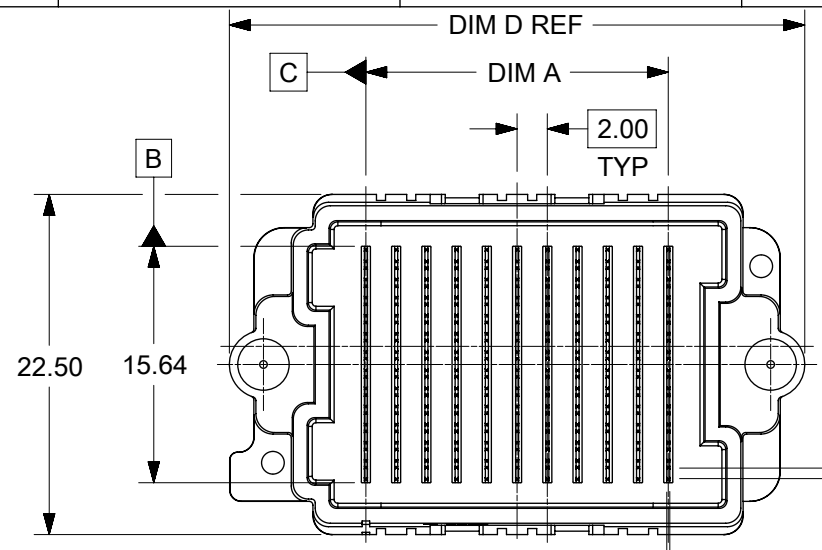

- NOTES:
- HOUSING MATERIAL: LCP, GLASS FILLED, UL94V-0, BLACK
CONTACT MATERIAL: HIGH PERFORMANCE ALLOY
GUIDE PIN MATERIAL: STAINLESS STEEL
SOLDER CHARGE MATERIAL: TIN OR TIN/LEAD SEE TABLE
 - CONTACT FINISH: SELECT GOLD: 30 MICRO-INCHES MINIMUM IN CONTACT AREA
SELECT TIN: 100 MICRO-INCHES MINIMUM IN TAIL AREA BOTH OVER NICKEL
 - PRODUCT SPECIFICATION: PS-45802-001
 - COSMETIC SPECIFICATION: PS-45499-002 CLASS B
 - PACKAGING SPECIFICATION: PK-45830-001 OR PK-45830-0002 SEE TABLES
 - C- IS THE CENTERLINE OF THE 2 END SLOTS. END SLOT CENTERLINES ARE ESTABLISHED USING 2 MEASUREMENTS FOR EACH SLOT TAKEN 7.28 EITHER SIDE -B-

DATE CODE
YEAR-DAY OF YEAR
LOCATED APPROX AS SHOWN

LEAD CODE
0= TIN LEAD (Sn63/Pb37)
2= TIN (Sn95.5/aG3.8/cU0.7)

ASSY MACHINE IDENTIFIER

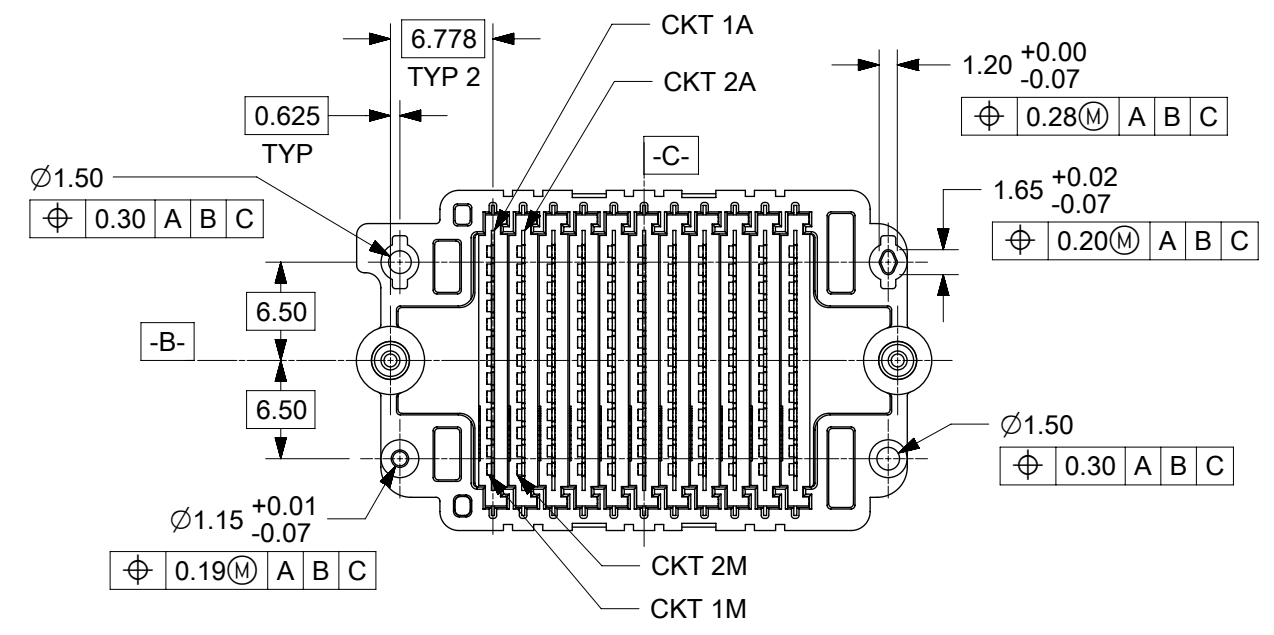
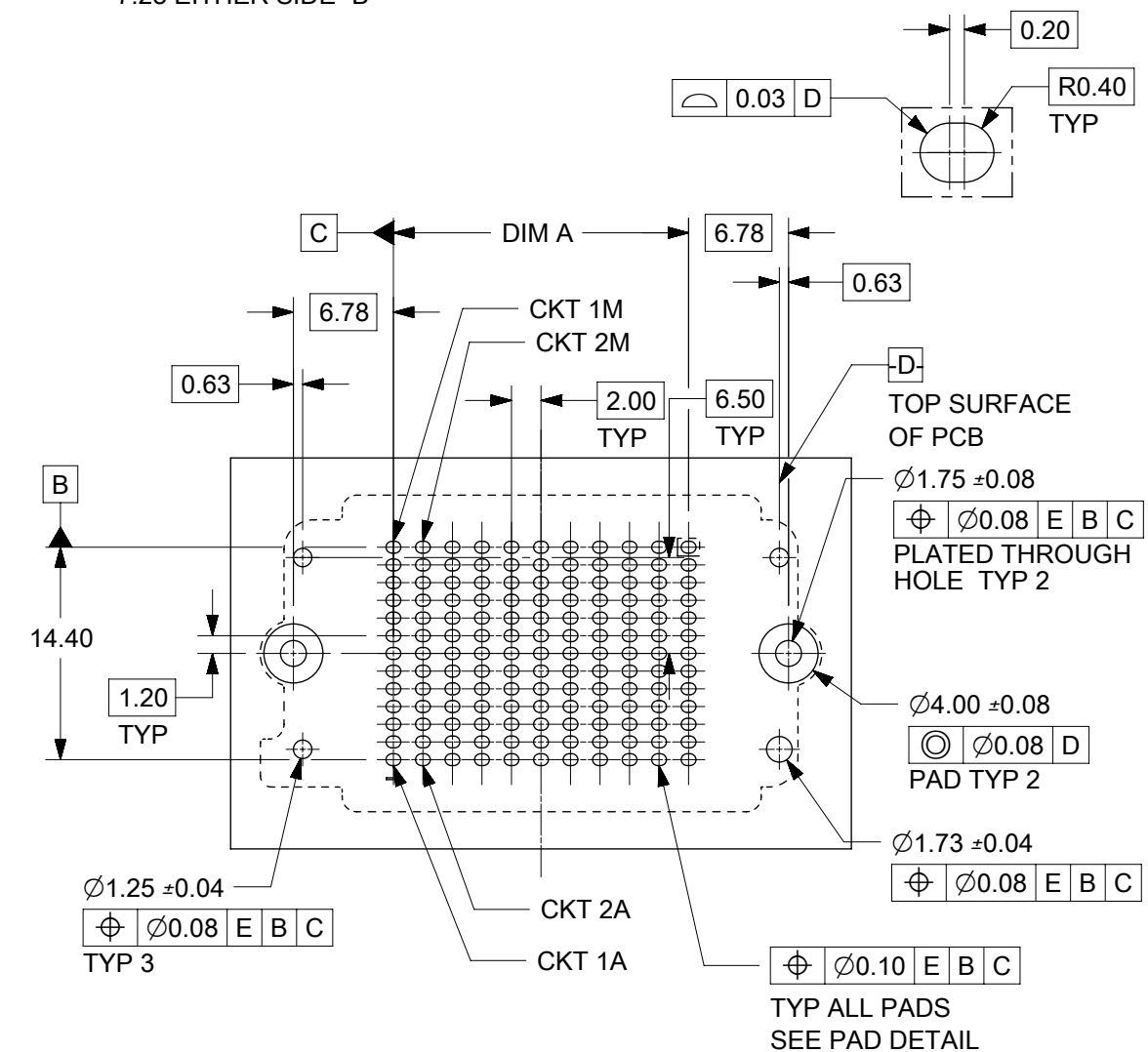
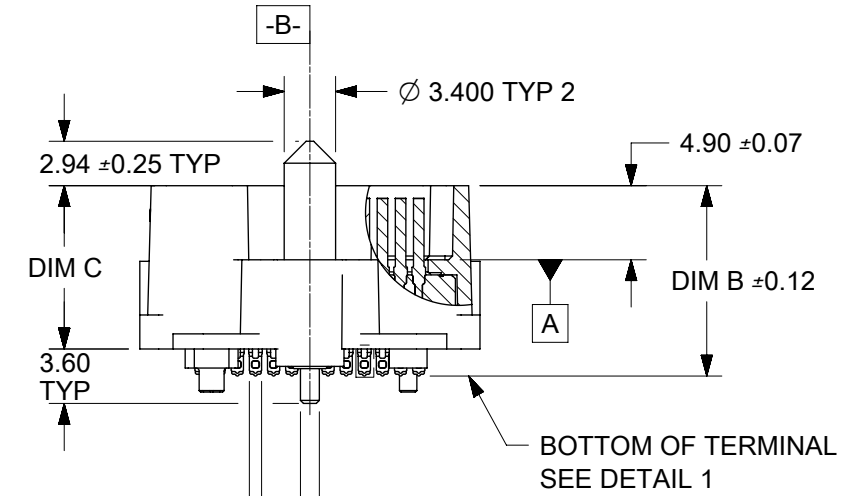
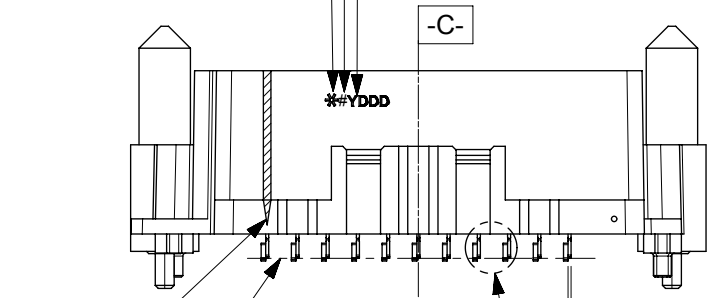

RECOMMENDED PCB LAYOUT: COMPONENT SIDE
PCB THICKNESS: NA

THIS DRAWING CONTAINS INFORMATION THAT IS PROPRIETARY TO MOLEX ELECTRONIC TECHNOLOGIES, LLC AND SHOULD NOT BE USED WITHOUT WRITTEN PERMISSION																																																																																							
DIMENSION UNITS	SCALE	CURRENT REV DESC: OBSOLETE PART NO.																																																																																					
mm	2:1	<table border="1"> <tr> <td colspan="2">molex</td> <td colspan="2">HDMEZZ PLUG ASSEMBLY WITH LONG GUIDE PINS</td> </tr> <tr> <td colspan="4">PRODUCT CUSTOMER DRAWING</td> </tr> <tr> <td>EC NO:</td> <td>631031</td> <td>DRWN:</td> <td>RPRABHUM</td> <td>2019/12/13</td> </tr> <tr> <td>4 PLACES</td> <td>±</td> <td>CHK'D:</td> <td>GGA</td> <td>2020/02/06</td> </tr> <tr> <td>3 PLACES</td> <td>±</td> <td>APPR:</td> <td>GGA</td> <td>2020/02/06</td> </tr> <tr> <td>2 PLACES</td> <td>±</td> <td colspan="2">INITIAL REVISION:</td> <td></td> </tr> <tr> <td>1 PLACE</td> <td>±</td> <td>DRWN:</td> <td>TGREGORI</td> <td>2010/09/09</td> </tr> <tr> <td>0 PLACES</td> <td>±</td> <td>APPR:</td> <td>JCOMERCI</td> <td>2011/03/15</td> </tr> <tr> <td>DRAFT WHERE APPLICABLE MUST REMAIN WITHIN DIMENSIONS</td> <td>THIRD ANGLE PROJECTION</td> <td>DRAWING</td> <td>SERIES</td> <td>MATERIAL NUMBER</td> <td>CUSTOMER</td> <td>DOCUMENT NUMBER</td> <td>DOC TYPE</td> <td>DOC PART</td> <td>REVISION</td> </tr> <tr> <td></td> <td></td> <td>B-SIZE</td> <td>45830</td> <td>SEE TABLE</td> <td>GENERAL MARKET</td> <td>SD-45830-0001</td> <td>PSD</td> <td>001</td> <td>J2</td> </tr> <tr> <td></td> <td></td> <td></td> <td></td> <td></td> <td></td> <td></td> <td></td> <td></td> <td>SHEET NUMBER</td> </tr> <tr> <td></td> <td></td> <td></td> <td></td> <td></td> <td></td> <td></td> <td></td> <td></td> <td>1 OF 3</td> </tr> </table>								molex		HDMEZZ PLUG ASSEMBLY WITH LONG GUIDE PINS		PRODUCT CUSTOMER DRAWING				EC NO:	631031	DRWN:	RPRABHUM	2019/12/13	4 PLACES	±	CHK'D:	GGA	2020/02/06	3 PLACES	±	APPR:	GGA	2020/02/06	2 PLACES	±	INITIAL REVISION:			1 PLACE	±	DRWN:	TGREGORI	2010/09/09	0 PLACES	±	APPR:	JCOMERCI	2011/03/15	DRAFT WHERE APPLICABLE MUST REMAIN WITHIN DIMENSIONS	THIRD ANGLE PROJECTION	DRAWING	SERIES	MATERIAL NUMBER	CUSTOMER	DOCUMENT NUMBER	DOC TYPE	DOC PART	REVISION			B-SIZE	45830	SEE TABLE	GENERAL MARKET	SD-45830-0001	PSD	001	J2										SHEET NUMBER										1 OF 3
molex										HDMEZZ PLUG ASSEMBLY WITH LONG GUIDE PINS																																																																													
PRODUCT CUSTOMER DRAWING																																																																																							
EC NO:	631031									DRWN:	RPRABHUM	2019/12/13																																																																											
4 PLACES	±									CHK'D:	GGA	2020/02/06																																																																											
3 PLACES	±	APPR:	GGA	2020/02/06																																																																																			
2 PLACES	±	INITIAL REVISION:																																																																																					
1 PLACE	±	DRWN:	TGREGORI	2010/09/09																																																																																			
0 PLACES	±	APPR:	JCOMERCI	2011/03/15																																																																																			
DRAFT WHERE APPLICABLE MUST REMAIN WITHIN DIMENSIONS	THIRD ANGLE PROJECTION	DRAWING	SERIES	MATERIAL NUMBER	CUSTOMER	DOCUMENT NUMBER	DOC TYPE	DOC PART	REVISION																																																																														
		B-SIZE	45830	SEE TABLE	GENERAL MARKET	SD-45830-0001	PSD	001	J2																																																																														
									SHEET NUMBER																																																																														
									1 OF 3																																																																														
<table border="1"> <tr> <td>DOCUMENT STATUS</td> <td>P1</td> <td>RELEASE DATE</td> <td>2020/02/06</td> <td>11:19:14</td> </tr> </table>										DOCUMENT STATUS	P1	RELEASE DATE	2020/02/06	11:19:14																																																																									
DOCUMENT STATUS	P1	RELEASE DATE	2020/02/06	11:19:14																																																																																			

			10	9	8	7	6	5	4	3	2	1	
TIN / LEAD PARTS LEAD CODE = "0"	STACK HEIGHT:			8mm	9mm	10mm	11mm	12mm	13mm	14mm	15mm	17mm	18mm
	DIM B			10.41	11.41	12.41	13.41	14.41	15.41	16.41	17.41	19.41	20.41
	DIM C			8.80	9.80	10.80	11.80	12.80	13.80	14.80	15.80	17.80	18.80
	ROWS	DIM A	DIM D	MATERIAL NO	MATERIAL NO	MATERIAL NO	MATERIAL NO	MATERIAL NO	MATERIAL NO	MATERIAL NO	MATERIAL NO	MATERIAL NO	MATERIAL NO
	7	12.00	30.06	45830-0007	45830-3007	45830-2007	45830-8007	45830-4007	45830-9007	45830-6007	45830-7007	45830-5007	45830-1007
	9	16.00	34.06	45830-0009	45830-3009	45830-2009	45830-8009	45830-4009	45830-9009	45830-6009	45830-7009	45830-5009	45830-1009
	11	20.00	38.06	45830-0011	45830-3011		45830-8011	45830-4011	45830-9011	45830-6011	45830-7011	45830-5011	45830-1111
	13	24.00	42.06	45830-0013	45830-3013	45830-2013	45830-8013	45830-4013	45830-9013	45830-6013	45830-7013	45830-5013	45830-1013
	15	28.00	46.06	45830-0015	45830-3015	45830-2015	45830-8015	45830-4015	45830-9015	45830-6015	45830-7015	45830-5015	45830-1015
	17	32.00	50.06	45830-0017	45830-3017	45830-2017	45830-8017	45830-4017	45830-9017	45830-6017	45830-7017	45830-5017	45830-1017
	19	36.00	54.06	45830-0019	45830-3019	45830-2019	45830-8019	45830-4019	45830-9019	45830-6019	45830-7019	45830-5019	45830-1019
	21	40.00	58.06	45830-0021	45830-3021	45830-2021	45830-8021	45830-4021	45830-9021	45830-6021	45830-7021	45830-5021	45830-1021
	23	44.00	62.06	45830-0023	45830-3023	45830-2023	45830-8023	45830-4023	45830-9023	45830-6023	45830-7023	45830-5023	45830-1023
	25	48.00	66.06	45830-0025	45830-3025	45830-2025	45830-8025	45830-4025	45830-9025	45830-6025	45830-7025	45830-5025	45830-1025
27	52.00	70.06	45830-0027	45830-3027	45830-2027	45830-8027	45830-4027	45830-9027	45830-6027	45830-7027	45830-5027	45830-1027	

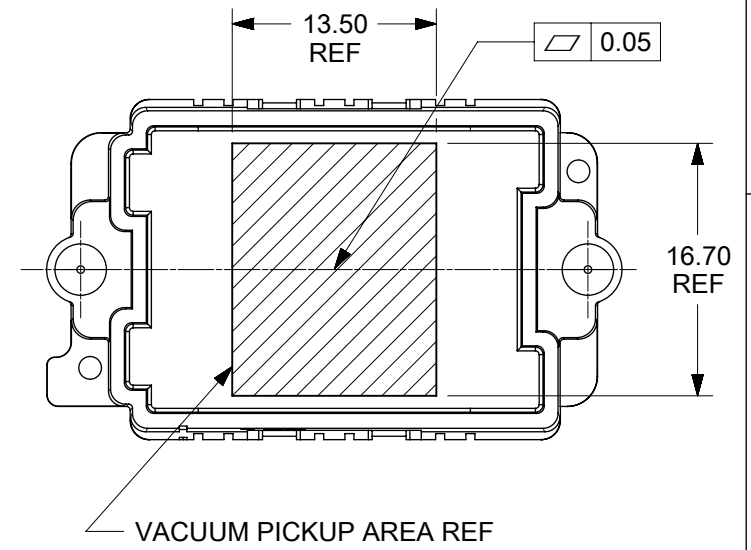

			10	9	8	7	6	5	4	3	2	1	
TIN PARTS LEAD CODE = "2"	STACK HEIGHT:			8mm	9mm	10mm	11mm	12mm	13mm	14mm	15mm	17mm	18mm
	DIM B			10.41	11.41	12.41	13.41	14.41	15.41	16.41	17.41	19.41	20.41
	DIM C			8.80	9.80	10.80	11.80	12.80	13.80	14.80	15.80	17.80	18.80
	ROWS	DIM A	DIM D	MATERIAL NO	MATERIAL NO	MATERIAL NO	MATERIAL NO	MATERIAL NO	MATERIAL NO	MATERIAL NO	MATERIAL NO	MATERIAL NO	MATERIAL NO
	7	12.00	30.06	45830-0207	45830-3207	45830-2207	45830-8207	45830-4207	45830-9207	45830-6207	45830-7207	45830-5207	45830-1207
	9	16.00	34.06	45830-0209	45830-3209	45830-2209	45830-8209	45830-4209	45830-9209	45830-6209	45830-7209	45830-5209	45830-1209
	11	20.00	38.06	45830-0211	45830-3211	45830-2211	45830-8211	45830-4211	45830-9211	45830-6211	45830-7211	45830-5211	45830-1211
	13	24.00	42.06	45830-0213	45830-3213	45830-2213	45830-8213	45830-4213	45830-9213	45830-6213	45830-7213	45830-5213	45830-1213
	15	28.00	46.06	45830-0215	45830-3215	45830-2215	45830-8215	45830-4215	45830-9215	45830-6215	45830-7215	45830-5215	45830-1215
	17	32.00	50.06	45830-0217	45830-3217	45830-2217	45830-8217	45830-4217	45830-9217	45830-6217	45830-7217	45830-5217	45830-1217
	19	36.00	54.06	45830-0219	45830-3219	45830-2219	45830-8219	45830-4219	45830-9219	45830-6219	45830-7219	45830-5219	45830-1219
	21	40.00	58.06	45830-0221	45830-3221	45830-2221	45830-8221	45830-4221	45830-9221	45830-6221	45830-7221	45830-5221	45830-1221
	23	44.00	62.06	45830-0223	45830-3223	45830-2223	45830-8223	45830-4223	45830-9223	45830-6223	45830-7223	45830-5223	45830-1223
	25	48.00	66.06	45830-0225	45830-3225	45830-2225	45830-8225	45830-4225	45830-9225	45830-6225	45830-7225	45830-5225	45830-1225
27	52.00	70.06	45830-0227	45830-3227	45830-2227	45830-8227	45830-4227	45830-9227	45830-6227	45830-7227	45830-5227	45830-1227	

ALL PARTS ON THIS SHEET ARE
PACKED IN STANDARD MOLEX TRAYS
PER PK-48030-001

NOTE:
1. SOLDER CHARGE COMPOSITION
TIN/LEAD: Sn 63/Pb 37
TIN: Sn 95.5/ Ag 3.8/ Cu 0.7

THIS DRAWING CONTAINS INFORMATION THAT IS PROPRIETARY TO MOLEX ELECTRONIC TECHNOLOGIES, LLC AND SHOULD NOT BE USED WITHOUT WRITTEN PERMISSION		CURRENT REV DESC: OBSOLETE PART NO.		molex	
DIMENSION UNITS mm	SCALE 2:1	EC NO: 631031			
GENERAL TOLERANCES (UNLESS SPECIFIED)		DRWN: RPRABHUM 2019/12/13		HDMEZZ PLUG ASSEMBLY WITH LONG GUIDE PINS	
ANGULAR TOL ± 0.5°		CHK'D: GGA 2020/02/06			
4 PLACES ±		APPR: GGA 2020/02/06		PRODUCT CUSTOMER DRAWING	
3 PLACES ± 0.05		INITIAL REVISION:			
2 PLACES ± 0.15		DRWN: TGREGORI 2010/09/09		DOCUMENT NUMBER SD-45830-0001	
1 PLACE ± 0.3		APPR: JCOMERCI 2011/03/15			
0 PLACES ±		THIRD ANGLE PROJECTION		DOC TYPE DOC PART REVISION PSD 001 J2	
DRAFT WHERE APPLICABLE MUST REMAIN WITHIN DIMENSIONS		DRAWING SERIES B-SIZE 45830			
DOCUMENT STATUS P1 RELEASE DATE 2020/02/06 11:19:14		MATERIAL NUMBER CUSTOMER SHEET NUMBER SEE TABLE GENERAL MARKET 2 OF 3			

F TIN / LEAD PARTS LEAD CODE = "0"	STACK HEIGHT:			8mm	9mm	10mm	11mm	12mm	13mm	14mm	15mm	17mm	18mm
	DIM B			10.41	11.41	12.41	13.41	14.41	15.41	16.41	17.41	19.41	20.41
	DIM C			8.80	9.80	10.80	11.80	12.80	13.80	14.80	15.80	17.80	18.80
	ROWS	DIM A	DIM D	MATERIAL NO	MATERIAL NO	MATERIAL NO	MATERIAL NO	MATERIAL NO	MATERIAL NO	MATERIAL NO	MATERIAL NO	MATERIAL NO	MATERIAL NO
	7	12.00	30.06	45830-0089	45830-3089	45830-2089	45830-8089	45830-4089	45830-9089	45830-6089	45830-7089	45830-5089	45830-1089
	9	16.00	34.06	45830-0090	45830-3090	45830-2090	45830-8090	45830-4090	45830-9090	45830-6090	45830-7090	45830-5090	45830-1090
	11	20.00	38.06	45830-0091	45830-3091	45830-2091	45830-8091	45830-4091	45830-9091	45830-6091	45830-7091	45830-5091	45830-1091
	13	24.00	42.06	45830-0092	45830-3092	45830-2092	45830-8092	45830-4092	45830-9092	45830-6092	45830-7092	45830-5092	45830-1092
	15	28.00	46.06	45830-0093	45830-3093	45830-2093	45830-8093	45830-4093	45830-9093	45830-6093	45830-7093	45830-5093	45830-1093
	17	32.00	50.06	45830-0094	45830-3094	45830-2094	45830-8094	45830-4094	45830-9094	45830-6094	45830-7094	45830-5094	45830-1094
	19	36.00	54.06	45830-0095	45830-3095	45830-2095	45830-8095	45830-4095	45830-9095	45830-6095	45830-7095	45830-5095	45830-1095
	21	40.00	58.06	45830-0096	45830-3096	45830-2096	45830-8096	45830-4096	45830-9096	45830-6096	45830-7096	45830-5096	45830-1096
	23	44.00	62.06	45830-0097	45830-3097	45830-2097	45830-8097	45830-4097	45830-9097	45830-6097	45830-7097	45830-5097	45830-1097
	25	48.00	66.06	45830-0098	45830-3098	45830-2098	45830-8098	45830-4098	45830-9098	45830-6098	45830-7098	45830-5098	45830-1098
27	52.00	70.06	45830-0099	45830-3099	45830-2099	45830-8099	45830-4099	45830-9099	45830-6099	45830-7099	45830-5099	45830-1099	

D TIN PARTS LEAD CODE = "2"	STACK HEIGHT:			8mm	9mm	10mm	11mm	12mm	13mm	14mm	15mm	17mm	18mm
	DIM B			10.41	11.41	12.41	13.41	14.41	15.41	16.41	17.41	19.41	20.41
	DIM C			8.80	9.80	10.80	11.80	12.80	13.80	14.80	15.80	17.80	18.80
	ROWS	DIM A	DIM D	MATERIAL NO	MATERIAL NO	MATERIAL NO	MATERIAL NO	MATERIAL NO	MATERIAL NO	MATERIAL NO	MATERIAL NO	MATERIAL NO	MATERIAL NO
	7	12.00	30.06	45830-0289	45830-3289	45830-2289	45830-8289	45830-4289	45830-9289	45830-6289	45830-7289	45830-5289	45830-1289
	9	16.00	34.06	45830-0290	45830-3290	45830-2290	45830-8290	45830-4290	45830-9290	45830-6290	45830-7290	45830-5290	45830-1290
	11	20.00	38.06	45830-0291	45830-3291	45830-2291	45830-8291	45830-4291	45830-9291	45830-6291	45830-7291	45830-5291	45830-1291
	13	24.00	42.06	45830-0292	45830-3292	45830-2292	45830-8292	45830-4292	45830-9292	45830-6292	45830-7292	45830-5292	45830-1292
	15	28.00	46.06	45830-0293	45830-3293	45830-2293	45830-8293	45830-4293	45830-9293	45830-6293	45830-7293	45830-5293	45830-1293 45830-0001
	17	32.00	50.06	45830-0294	45830-3294	45830-2294	45830-8294	45830-4294	45830-9294	45830-6294	45830-7294	45830-5294	45830-1294
	19	36.00	54.06	45830-0295	45830-3295	45830-2295	45830-8295	45830-4295	45830-9295	45830-6295	45830-7295	45830-5295	45830-1295
	21	40.00	58.06	45830-0296	45830-3296	45830-2296	45830-8296	45830-4296	45830-9296	45830-6296	45830-7296	45830-5296	45830-1296
	23	44.00	62.06	45830-0297	45830-3297	45830-2297	45830-8297	45830-4297	45830-9297	45830-6297	45830-7297	45830-5297	45830-1297
	25	48.00	66.06	45830-0298	45830-3298	45830-2298	45830-8298	45830-4298	45830-9298	45830-6298	45830-7298	45830-5298	45830-1298
27	52.00	70.06	45830-0299	45830-3299	45830-2299	45830-8299	45830-4299	45830-9299	45830-6299	45830-7299	45830-5299	45830-1299	

ALL PARTS ON THIS SHEET ARE PACKED
IN JEDEC STYLE TRAYS PER PK-45830-0002

THIS DRAWING CONTAINS INFORMATION THAT IS PROPRIETARY TO MOLEX ELECTRONIC TECHNOLOGIES, LLC AND SHOULD NOT BE USED WITHOUT WRITTEN PERMISSION														
DIMENSION UNITS		SCALE		CURRENT REV DESC: OBSOLETE PART NO.										
mm		1:1		molex HDMEZZ PLUG ASSEMBLY WITH LONG GUIDE PINS PRODUCT CUSTOMER DRAWING										
GENERAL TOLERANCES (UNLESS SPECIFIED)														
ANGULAR TOL		± 0.5°												
4 PLACES		±												
3 PLACES		± 0.05												
2 PLACES		± 0.15		EC NO: 631031		2019/12/13		DOCUMENT NUMBER SD-45830-0001			DOC TYPE		DOC PART	REVISION
1 PLACE		± 0.3		DRWN: RPRABHUM		2020/02/06					PSD	001	J2	
0 PLACES		±		CHK'D: GGA		2020/02/06					GENERAL MARKET	3 OF 3		
DRAFT WHERE APPLICABLE MUST REMAIN WITHIN DIMENSIONS		THIRD ANGLE PROJECTION		DRAWING		SERIES					MATERIAL NUMBER		CUSTOMER	
				B-SIZE		45830		SEE TABLE		GENERAL MARKET		3 OF 3		
INITIAL REVISION: DRWN: TGREGORI 2010/09/09 APPR: JCOMERCI 2011/03/15														
DOCUMENT STATUS	P1	RELEASE DATE	2020/02/06	11:19:14	9	8	7	6	5	4	3	2	1	

		10	9	8	7	6	5	4	3	2	1		
TIN / LEAD PARTS LEAD CODE = "0"	STACK HEIGHT:		8mm	9mm	10mm	11mm	12mm	13mm	14mm	15mm	17mm	18mm	
	DIM B		10.41	11.41	12.41	13.41	14.41	15.41	16.41	17.41	19.41	20.41	
	DIM C		8.80	9.80	10.80	11.80	12.80	13.80	14.80	15.80	17.80	18.80	
	ROWS	DIM A	DIM D	MATERIAL NO	MATERIAL NO	MATERIAL NO	MATERIAL NO	MATERIAL NO	MATERIAL NO	MATERIAL NO	MATERIAL NO	MATERIAL NO	
	7	12.00	30.06	45830-0707	45830-3707	45830-2707	45830-8707	45830-4707	45830-9707	45830-6707	45830-7707	45830-5707	45830-1707
	9	16.00	34.06	45830-0709	45830-3709	45830-2709	45830-8709	45830-4709	45830-9709	45830-6709	45830-7709	45830-5709	45830-1709
	11	20.00	38.06	45830-0711	45830-3711	45830-2711	45830-8711	45830-4711	45830-9711	45830-6711	45830-7711	45830-5711	45830-1711
	13	24.00	42.06	45830-0713	45830-3713	45830-2713	45830-8713	45830-4713	45830-9713	45830-6713	45830-7713	45830-5713	45830-1713
	15	28.00	46.06	45830-0715	45830-3715	45830-2715	45830-8715	45830-4715	45830-9715	45830-6715	45830-7715	45830-5715	45830-1715
	17	32.00	50.06	45830-0717	45830-3717	45830-2717	45830-8717	45830-4717	45830-9717	45830-6717	45830-7717	45830-5717	45830-1717
	19	36.00	54.06	45830-0719	45830-3719	45830-2719	45830-8719	45830-4719	45830-9719	45830-6719	45830-7719	45830-5719	45830-1719
	21	40.00	58.06	45830-0721	45830-3721	45830-2721	45830-8721	45830-4721	45830-9721	45830-6721	45830-7721	45830-5721	45830-1721
	23	44.00	62.06	45830-0723	45830-3723	45830-2723	45830-8723	45830-4723	45830-9723	45830-6723	45830-7723	45830-5723	45830-1723
	25	48.00	66.06	45830-0725	45830-3725	45830-2725	45830-8725	45830-4725	45830-9725	45830-6725	45830-7725	45830-5725	45830-1725
27	52.00	70.06	45830-0727	45830-3727	45830-2727	45830-8727	45830-4727	45830-9727	45830-6727	45830-7727	45830-5727	45830-1727	

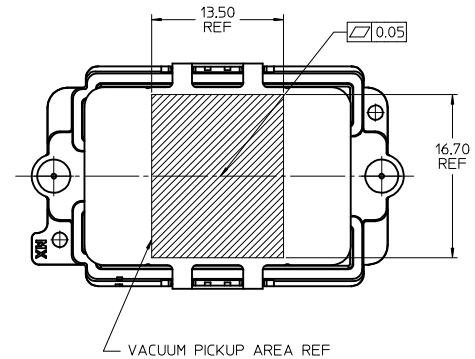

		10	9	8	7	6	5	4	3	2	1		
TIN PARTS LEAD CODE = "2"	STACK HEIGHT:		8mm	9mm	10mm	11mm	12mm	13mm	14mm	15mm	17mm	18mm	
	DIM B		10.41	11.41	12.41	13.41	14.41	15.41	16.41	17.41	19.41	20.41	
	DIM C		8.80	9.80	10.80	11.80	12.80	13.80	14.80	15.80	17.80	18.80	
	ROWS	DIM A	DIM D	MATERIAL NO	MATERIAL NO	MATERIAL NO	MATERIAL NO	MATERIAL NO	MATERIAL NO	MATERIAL NO	MATERIAL NO	MATERIAL NO	
	7	12.00	30.06	45830-0807	45830-3807	45830-2807	45830-8807	45830-4807	45830-9807	45830-6807	45830-7807	45830-5807	45830-1807
	9	16.00	34.06	45830-0809	45830-3809	45830-2809	45830-8809	45830-4809	45830-9809	45830-6809	45830-7809	45830-5809	45830-1809
	11	20.00	38.06	45830-0811	45830-3811	45830-2811	45830-8811	45830-4811	45830-9811	45830-6811	45830-7811	45830-5811	45830-1811
	13	24.00	42.06	45830-0813	45830-3813	45830-2813	45830-8813	45830-4813	45830-9813	45830-6813	45830-7813	45830-5813	45830-1813
	15	28.00	46.06	45830-0815	45830-3815	45830-2815	45830-8815	45830-4815	45830-9815	45830-6815	45830-7815	45830-5815	45830-1815
	17	32.00	50.06	45830-0817	45830-3817	45830-2817	45830-8817	45830-4817	45830-9817	45830-6817	45830-7817	45830-5817	45830-1817
	19	36.00	54.06	45830-0819	45830-3819	45830-2819	45830-8819	45830-4819	45830-9819	45830-6819	45830-7819	45830-5819	45830-1819
	21	40.00	58.06	45830-0821	45830-3821	45830-2821	45830-8821	45830-4821	45830-9821	45830-6821	45830-7821	45830-5821	45830-1821
	23	44.00	62.06	45830-0823	45830-3823	45830-2823	45830-8823	45830-4823	45830-9823	45830-6823	45830-7823	45830-5823	45830-1823
	25	48.00	66.06	45830-0825	45830-3825	45830-2825	45830-8825	45830-4825	45830-9825	45830-6825	45830-7825	45830-5825	45830-1825
27	52.00	70.06	45830-0827	45830-3827	45830-2827	45830-8827	45830-4827	45830-9827	45830-6827	45830-7827	45830-5827	45830-1827	

ALL PARTS ON THIS SHEET ARE PACKED IN STANDARD MOLEX TRAYS PER PK-45830-001

NOTE:
1. SOLDER CHARGE COMPOSITION
TIN/LEAD: Sn 63/Pb 37
TIN: Sn 95.5/ Ag 3.8/ Cu 0.7

SEE SHEET 1 EC NO: UCP2016-3732 DRAWS: VANGONI 2016/03/24 CHKD: MCAIN 2016/03/24 APPR: DMCGOWAN 2016/03/31	QUALITY SYMBOLS $\nabla F=0$ $\nabla E=0$ $\nabla D=0$	GENERAL TOLERANCES (UNLESS SPECIFIED)		DIMENSION STYLE MM ONLY		SCALE 2:1	DESIGN UNITS METRIC	THIRD ANGLE PROJECTION			
		4 PLACES \pm --- \pm ---	mm INCH	DRAWN BY TREGOR I	DATE 2010/09/09	HDMEZZ PLUG ASSEMBLY WITH SHORT GUIDE PINS					
		3 PLACES \pm 0.05 \pm ---		CHECKED BY	DATE						
		2 PLACES \pm 0.15 \pm ---		APPROVED BY JCOMERCI	DATE 2010/10/07	molex		DOCUMENT NO. SD-45830-0002	SHEET NO. 2 OF 3		
ANGULAR \pm 1/2° DRAFT WHERE APPLICABLE MUST REMAIN WITHIN DIMENSIONS		SEE TABLE		THIS DRAWING CONTAINS INFORMATION THAT IS PROPRIETARY TO MOLEX INCORPORATED AND SHOULD NOT BE USED WITHOUT WRITTEN PERMISSION							

		10	9	8	7	6	5	4	3	2	1		
F TIN / LEAD PARTS LEAD CODE = "0"	STACK HEIGHT:		8mm	9mm	10mm	11mm	12mm	13mm	14mm	15mm	17mm	18mm	
	DIM B		10.41	11.41	12.41	13.41	14.41	15.41	16.41	17.41	19.41	20.41	
	DIM C		8.80	9.80	10.80	11.80	12.80	13.80	14.80	15.80	17.80	18.80	
	ROWS	DIM A	DIM D	MATERIAL NO	MATERIAL NO	MATERIAL NO	MATERIAL NO	MATERIAL NO	MATERIAL NO	MATERIAL NO	MATERIAL NO	MATERIAL NO	
	7	12.00	30.06	45830-0789	45830-3789	45830-2789	45830-8789	45830-4789	45830-9789	45830-6789	45830-7789	45830-5789	45830-1789
	9	16.00	34.06	45830-0790	45830-3790	45830-2790	45830-8790	45830-4790	45830-9790	45830-6790	45830-7790	45830-5790	45830-1790
	11	20.00	38.06	45830-0791	45830-3791	45830-2791	45830-8791	45830-4791	45830-9791	45830-6791	45830-7791	45830-5791	45830-1791
	13	24.00	42.06	45830-0792	45830-3792	45830-2792	45830-8792	45830-4792	45830-9792	45830-6792	45830-7792	45830-5792	45830-1792
	15	28.00	46.06	45830-0793	45830-3793	45830-2793	45830-8793	45830-4793	45830-9793	45830-6793	45830-7793	45830-5793	45830-1793
	17	32.00	50.06	45830-0794	45830-3794	45830-2794	45830-8794	45830-4794	45830-9794	45830-6794	45830-7794	45830-5794	45830-1794
	19	36.00	54.06	45830-0795	45830-3795	45830-2795	45830-8795	45830-4795	45830-9795	45830-6795	45830-7795	45830-5795	45830-1795
	21	40.00	58.06	45830-0796	45830-3796	45830-2796	45830-8796	45830-4796	45830-9796	45830-6796	45830-7796	45830-5796	45830-1796
	23	44.00	62.06	45830-0797	45830-3797	45830-2797	45830-8797	45830-4797	45830-9797	45830-6797	45830-7797	45830-5797	45830-1797
25	48.00	66.06	45830-0798	45830-3798	45830-2798	45830-8798	45830-4798	45830-9798	45830-6798	45830-7798	45830-5798	45830-1798	
27	52.00	70.06	45830-0799	45830-3799	45830-2799	45830-8799	45830-4799	45830-9799	45830-6799	45830-7799	45830-5799	45830-1799	

		10	9	8	7	6	5	4	3	2	1		
D TIN PARTS LEAD CODE = "2"	STACK HEIGHT:		8mm	9mm	10mm	11mm	12mm	13mm	14mm	15mm	17mm	18mm	
	DIM B		10.41	11.41	12.41	13.41	14.41	15.41	16.41	17.41	19.41	20.41	
	DIM C		8.80	9.80	10.80	11.80	12.80	13.80	14.80	15.80	17.80	18.80	
	ROWS	DIM A	DIM D	MATERIAL NO	MATERIAL NO	MATERIAL NO	MATERIAL NO	MATERIAL NO	MATERIAL NO	MATERIAL NO	MATERIAL NO	MATERIAL NO	
	7	12.00	30.06	45830-0889	45830-3889	45830-2889	45830-8889	45830-4889	45830-9889	45830-6889	45830-7889	45830-5889	45830-1889
	9	16.00	34.06	45830-0890	45830-3890	45830-2890	45830-8890	45830-4890	45830-9890	45830-6890	45830-7890	45830-5890	45830-1890
	11	20.00	38.06	45830-0891	45830-3891	45830-2891	45830-8891	45830-4891	45830-9891	45830-6891	45830-7891	45830-5891	45830-1891
	13	24.00	42.06	45830-0892	45830-3892	45830-2892	45830-8892	45830-4892	45830-9892	45830-6892	45830-7892	45830-5892	45830-1892
	15	28.00	46.06	45830-0893	45830-3893	45830-2893	45830-8893	45830-4893	45830-9893	45830-6893	45830-7893	45830-5893	45830-1893
	17	32.00	50.06	45830-0894	45830-3894	45830-2894	45830-8894	45830-4894	45830-9894	45830-6894	45830-7894	45830-5894	45830-1894
	19	36.00	54.06	45830-0895	45830-3895	45830-2895	45830-8895	45830-4895	45830-9895	45830-6895	45830-7895	45830-5895	45830-1895
	21	40.00	58.06	45830-0896	45830-3896	45830-2896	45830-8896	45830-4896	45830-9896	45830-6896	45830-7896	45830-5896	45830-1896
	23	44.00	62.06	45830-0897	45830-3897	45830-2897	45830-8897	45830-4897	45830-9897	45830-6897	45830-7897	45830-5897	45830-1897
25	48.00	66.06	45830-0898	45830-3898	45830-2898	45830-8898	45830-4898	45830-9898	45830-6898	45830-7898	45830-5898	45830-1898	
27	52.00	70.06	45830-0899	45830-3899	45830-2899	45830-8899	45830-4899	45830-9899	45830-6899	45830-7899	45830-5899	45830-1899	

ALL PARTS ON THIS SHEET ARE PACKED IN JEDEC STYLE TRAYS PER PK-45830-0002

SEE SHEET 1 EC NO: UCP2016-3732 DRAWN: SVANG01 2016/03/24 CHKD: MCAIN 2016/03/24 APPR: DMC GOWAN 2016/03/31	QUALITY SYMBOLS	GENERAL TOLERANCES (UNLESS SPECIFIED)		DIMENSION STYLE		SCALE	DESIGN UNITS	THIRD ANGLE PROJECTION	
	▽=0	mm INCH		MM ONLY		1:1	METRIC	TITLE	
	▽=0	4 PLACES ± --- ± ---		DRAWN BY DATE		HDMEZZ PLUG ASSEMBLY WITH SHORT GUIDE PINS			
	▽=0	3 PLACES ± 0.05 ± ---		TREGOR I 2010/09/09					
	2 PLACES ± 0.15 ± ---		CHECKED BY DATE		molex				
	1 PLACE ± 0.3 ± ---		APPROVED BY DATE						
	0 PLACE ± ±		JCOMERC I 2010/10/07		MATERIAL NO.		DOCUMENT NO.		SHEET NO.
	ANGULAR ±1/2°		DRAFT WHERE APPLICABLE		SEE TABLE		SD-45830-0002		3 OF 3
	MUST REMAIN WITHIN DIMENSIONS		SIZE B		THIS DRAWING CONTAINS INFORMATION THAT IS PROPRIETARY TO MOLEX INCORPORATED AND SHOULD NOT BE USED WITHOUT WRITTEN PERMISSION				

		10	9	8	7	6	5	4	3	2	1		
TIN / LEAD PARTS LEAD CODE = "0"	STACK HEIGHT:		8mm	9mm	10mm	11mm	12mm	13mm	14mm	15mm	17mm	18mm	
	DIM B		10.41	11.41	12.41	13.41	14.41	15.41	16.41	17.41	19.41	20.41	
	DIM C		8.80	9.80	10.80	11.80	12.80	13.80	14.80	15.80	17.80	18.80	
	ROWS	DIM A	DIM D	MATERIAL NO	MATERIAL NO	MATERIAL NO	MATERIAL NO	MATERIAL NO	MATERIAL NO	MATERIAL NO	MATERIAL NO	MATERIAL NO	
	7	12.00	30.06	45830-0707	45830-3707	45830-2707	45830-8707	45830-4707	45830-9707	45830-6707	45830-7707	45830-5707	45830-1707
	9	16.00	34.06	45830-0709	45830-3709	45830-2709	45830-8709	45830-4709	45830-9709	45830-6709	45830-7709	45830-5709	45830-1709
	11	20.00	38.06	45830-0711	45830-3711	45830-2711	45830-8711	45830-4711	45830-9711	45830-6711	45830-7711	45830-5711	45830-1711
	13	24.00	42.06	45830-0713	45830-3713	45830-2713	45830-8713	45830-4713	45830-9713	45830-6713	45830-7713	45830-5713	45830-1713
	15	28.00	46.06	45830-0715	45830-3715	45830-2715	45830-8715	45830-4715	45830-9715	45830-6715	45830-7715	45830-5715	45830-1715
	17	32.00	50.06	45830-0717	45830-3717	45830-2717	45830-8717	45830-4717	45830-9717	45830-6717	45830-7717	45830-5717	45830-1717
	19	36.00	54.06	45830-0719	45830-3719	45830-2719	45830-8719	45830-4719	45830-9719	45830-6719	45830-7719	45830-5719	45830-1719
	21	40.00	58.06	45830-0721	45830-3721	45830-2721	45830-8721	45830-4721	45830-9721	45830-6721	45830-7721	45830-5721	45830-1721
	23	44.00	62.06	45830-0723	45830-3723	45830-2723	45830-8723	45830-4723	45830-9723	45830-6723	45830-7723	45830-5723	45830-1723
25	48.00	66.06	45830-0725	45830-3725	45830-2725	45830-8725	45830-4725	45830-9725	45830-6725	45830-7725	45830-5725	45830-1725	
27	52.00	70.06	45830-0727	45830-3727	45830-2727	45830-8727	45830-4727	45830-9727	45830-6727	45830-7727	45830-5727	45830-1727	

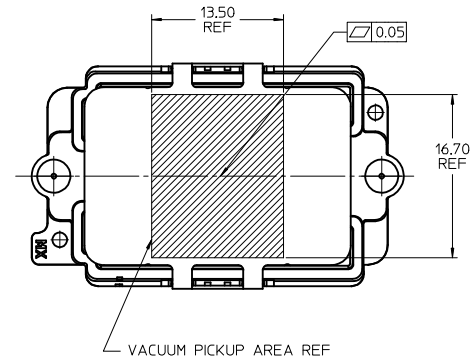

		10	9	8	7	6	5	4	3	2	1		
TIN PARTS LEAD CODE = "2"	STACK HEIGHT:		8mm	9mm	10mm	11mm	12mm	13mm	14mm	15mm	17mm	18mm	
	DIM B		10.41	11.41	12.41	13.41	14.41	15.41	16.41	17.41	19.41	20.41	
	DIM C		8.80	9.80	10.80	11.80	12.80	13.80	14.80	15.80	17.80	18.80	
	ROWS	DIM A	DIM D	MATERIAL NO	MATERIAL NO	MATERIAL NO	MATERIAL NO	MATERIAL NO	MATERIAL NO	MATERIAL NO	MATERIAL NO	MATERIAL NO	
	7	12.00	30.06	45830-0807	45830-3807	45830-2807	45830-8807	45830-4807	45830-9807	45830-6807	45830-7807	45830-5807	45830-1807
	9	16.00	34.06	45830-0809	45830-3809	45830-2809	45830-8809	45830-4809	45830-9809	45830-6809	45830-7809	45830-5809	45830-1809
	11	20.00	38.06	45830-0811	45830-3811	45830-2811	45830-8811	45830-4811	45830-9811	45830-6811	45830-7811	45830-5811	45830-1811
	13	24.00	42.06	45830-0813	45830-3813	45830-2813	45830-8813	45830-4813	45830-9813	45830-6813	45830-7813	45830-5813	45830-1813
	15	28.00	46.06	45830-0815	45830-3815	45830-2815	45830-8815	45830-4815	45830-9815	45830-6815	45830-7815	45830-5815	45830-1815
	17	32.00	50.06	45830-0817	45830-3817	45830-2817	45830-8817	45830-4817	45830-9817	45830-6817	45830-7817	45830-5817	45830-1817
	19	36.00	54.06	45830-0819	45830-3819	45830-2819	45830-8819	45830-4819	45830-9819	45830-6819	45830-7819	45830-5819	45830-1819
	21	40.00	58.06	45830-0821	45830-3821	45830-2821	45830-8821	45830-4821	45830-9821	45830-6821	45830-7821	45830-5821	45830-1821
	23	44.00	62.06	45830-0823	45830-3823	45830-2823	45830-8823	45830-4823	45830-9823	45830-6823	45830-7823	45830-5823	45830-1823
25	48.00	66.06	45830-0825	45830-3825	45830-2825	45830-8825	45830-4825	45830-9825	45830-6825	45830-7825	45830-5825	45830-1825	
27	52.00	70.06	45830-0827	45830-3827	45830-2827	45830-8827	45830-4827	45830-9827	45830-6827	45830-7827	45830-5827	45830-1827	

ALL PARTS ON THIS SHEET ARE PACKED IN STANDARD MOLEX TRAYS PER PK-45830-001

NOTE:
1. SOLDER CHARGE COMPOSITION
TIN/LEAD: Sn 63/Pb 37
TIN: Sn 95.5/ Ag 3.8/ Cu 0.7

SEE SHEET 1 EC NO: UCP2016-3732 DRAWN: SVANG01 2016/03/24 CHKD: MCA IN 2016/03/24 APPR: DMCGOWAN 2016/03/31	QUALITY SYMBOLS $\nabla F = 0$ $\nabla E = 0$ $\nabla D = 0$	GENERAL TOLERANCES (UNLESS SPECIFIED)		DIMENSION STYLE MM ONLY		SCALE 2:1	DESIGN UNITS METRIC	THIRD ANGLE PROJECTION			
		4 PLACES \pm --- \pm ---	mm INCH	DRAWN BY TREGOR I	DATE 2010/09/09	HDMEZZ PLUG ASSEMBLY WITH SHORT GUIDE PINS					
		3 PLACES ± 0.05 \pm ---		CHECKED BY	DATE						
		2 PLACES ± 0.15 \pm ---		APPROVED BY JCOMERCI	DATE 2010/10/07	MATERIAL NO. SEE TABLE		DOCUMENT NO. SD-45830-0002	SHEET NO. 2 OF 3		
ANGULAR $\pm 1/2^\circ$ DRAFT WHERE APPLICABLE MUST REMAIN WITHIN DIMENSIONS		THIS DRAWING CONTAINS INFORMATION THAT IS PROPRIETARY TO MOLEX INCORPORATED AND SHOULD NOT BE USED WITHOUT WRITTEN PERMISSION									

		10	9	8	7	6	5	4	3	2	1		
F TIN / LEAD PARTS LEAD CODE = "0"	STACK HEIGHT:		8mm	9mm	10mm	11mm	12mm	13mm	14mm	15mm	17mm	18mm	
	DIM B		10.41	11.41	12.41	13.41	14.41	15.41	16.41	17.41	19.41	20.41	
	DIM C		8.80	9.80	10.80	11.80	12.80	13.80	14.80	15.80	17.80	18.80	
	ROWS	DIM A	DIM D	MATERIAL NO	MATERIAL NO	MATERIAL NO	MATERIAL NO	MATERIAL NO	MATERIAL NO	MATERIAL NO	MATERIAL NO	MATERIAL NO	
	7	12.00	30.06	45830-0789	45830-3789	45830-2789	45830-8789	45830-4789	45830-9789	45830-6789	45830-7789	45830-5789	45830-1789
	9	16.00	34.06	45830-0790	45830-3790	45830-2790	45830-8790	45830-4790	45830-9790	45830-6790	45830-7790	45830-5790	45830-1790
	11	20.00	38.06	45830-0791	45830-3791	45830-2791	45830-8791	45830-4791	45830-9791	45830-6791	45830-7791	45830-5791	45830-1791
	13	24.00	42.06	45830-0792	45830-3792	45830-2792	45830-8792	45830-4792	45830-9792	45830-6792	45830-7792	45830-5792	45830-1792
	15	28.00	46.06	45830-0793	45830-3793	45830-2793	45830-8793	45830-4793	45830-9793	45830-6793	45830-7793	45830-5793	45830-1793
	17	32.00	50.06	45830-0794	45830-3794	45830-2794	45830-8794	45830-4794	45830-9794	45830-6794	45830-7794	45830-5794	45830-1794
	19	36.00	54.06	45830-0795	45830-3795	45830-2795	45830-8795	45830-4795	45830-9795	45830-6795	45830-7795	45830-5795	45830-1795
	21	40.00	58.06	45830-0796	45830-3796	45830-2796	45830-8796	45830-4796	45830-9796	45830-6796	45830-7796	45830-5796	45830-1796
	23	44.00	62.06	45830-0797	45830-3797	45830-2797	45830-8797	45830-4797	45830-9797	45830-6797	45830-7797	45830-5797	45830-1797
25	48.00	66.06	45830-0798	45830-3798	45830-2798	45830-8798	45830-4798	45830-9798	45830-6798	45830-7798	45830-5798	45830-1798	
27	52.00	70.06	45830-0799	45830-3799	45830-2799	45830-8799	45830-4799	45830-9799	45830-6799	45830-7799	45830-5799	45830-1799	

		10	9	8	7	6	5	4	3	2	1		
D TIN PARTS LEAD CODE = "2"	STACK HEIGHT:		8mm	9mm	10mm	11mm	12mm	13mm	14mm	15mm	17mm	18mm	
	DIM B		10.41	11.41	12.41	13.41	14.41	15.41	16.41	17.41	19.41	20.41	
	DIM C		8.80	9.80	10.80	11.80	12.80	13.80	14.80	15.80	17.80	18.80	
	ROWS	DIM A	DIM D	MATERIAL NO	MATERIAL NO	MATERIAL NO	MATERIAL NO	MATERIAL NO	MATERIAL NO	MATERIAL NO	MATERIAL NO	MATERIAL NO	
	7	12.00	30.06	45830-0889	45830-3889	45830-2889	45830-8889	45830-4889	45830-9889	45830-6889	45830-7889	45830-5889	45830-1889
	9	16.00	34.06	45830-0890	45830-3890	45830-2890	45830-8890	45830-4890	45830-9890	45830-6890	45830-7890	45830-5890	45830-1890
	11	20.00	38.06	45830-0891	45830-3891	45830-2891	45830-8891	45830-4891	45830-9891	45830-6891	45830-7891	45830-5891	45830-1891
	13	24.00	42.06	45830-0892	45830-3892	45830-2892	45830-8892	45830-4892	45830-9892	45830-6892	45830-7892	45830-5892	45830-1892
	15	28.00	46.06	45830-0893	45830-3893	45830-2893	45830-8893	45830-4893	45830-9893	45830-6893	45830-7893	45830-5893	45830-1893
	17	32.00	50.06	45830-0894	45830-3894	45830-2894	45830-8894	45830-4894	45830-9894	45830-6894	45830-7894	45830-5894	45830-1894
	19	36.00	54.06	45830-0895	45830-3895	45830-2895	45830-8895	45830-4895	45830-9895	45830-6895	45830-7895	45830-5895	45830-1895
	21	40.00	58.06	45830-0896	45830-3896	45830-2896	45830-8896	45830-4896	45830-9896	45830-6896	45830-7896	45830-5896	45830-1896
	23	44.00	62.06	45830-0897	45830-3897	45830-2897	45830-8897	45830-4897	45830-9897	45830-6897	45830-7897	45830-5897	45830-1897
25	48.00	66.06	45830-0898	45830-3898	45830-2898	45830-8898	45830-4898	45830-9898	45830-6898	45830-7898	45830-5898	45830-1898	
27	52.00	70.06	45830-0899	45830-3899	45830-2899	45830-8899	45830-4899	45830-9899	45830-6899	45830-7899	45830-5899	45830-1899	

ALL PARTS ON THIS SHEET ARE PACKED IN JEDEC STYLE TRAYS PER PK-45830-0002

SEE SHEET 1 EC NO: UCP2016-3732 DRAWN: SVANG01 2016/03/24 CHKD: MCAIN 2016/03/24 APPR: DMC GOWAN 2016/03/31	QUALITY SYMBOLS	GENERAL TOLERANCES (UNLESS SPECIFIED)		DIMENSION STYLE MM ONLY		SCALE 1:1	DESIGN UNITS METRIC	THIRD ANGLE PROJECTION	
	▽=0	4 PLACES ± --- ± ---	mm	INCH	DRAWN BY TGREGORI	DATE 2010/09/09	TITLE HDMEZZ PLUG ASSEMBLY WITH SHORT GUIDE PINS		
	▽=0	3 PLACES ± 0.05 ± ---			CHECKED BY	DATE			
	▽=0	2 PLACES ± 0.15 ± ---	ANGULAR ±1/2°		APPROVED BY JCOMERC I		DATE 2010/10/07	DOCUMENT NO. SD-45830-0002	
	1 PLACE ± 0.3 ± ---	DRAFT WHERE APPLICABLE MUST REMAIN WITHIN DIMENSIONS		MATERIAL NO.					
	0 PLACE ± ±			SIZE B		THIS DRAWING CONTAINS INFORMATION THAT IS PROPRIETARY TO MOLEX INCORPORATED AND SHOULD NOT BE USED WITHOUT WRITTEN PERMISSION			