



MIC22700YML Evaluation Board

Integrated 7A Synchronous Buck Regulator

General Description

The Micrel MIC22700 is a high-efficiency, 7A, integrated, synchronous buck (step-down) regulator. The MIC22700 is optimized for highest power density and achieves over 90% efficiency while switching at 1MHz with only 1μH inductor and 100μF output capacitor. The MIC22700 features integrated 7A MOSFETs, flexible sequencing and tracking abilities.

This board enables the evaluation of the MIC22700; a high power density, synchronous buck regulator. The board is optimized for ease of testing, with all the components on a single side. The voltage-mode feedback loop is designed to allow high bandwidth with just two external compensation components. The high-side MOSFET is a P-Channel, allowing duty cycle control up to 100%. The ultra-high-speed control loop keeps the output voltage within regulation even under extreme transient load swings commonly found in FPGAs and low voltage ASICs. The output voltage can be adjusted down to 0.7V to address all low voltage power needs. The MIC22700 offers a full-range of sequencing and tracking options. The enable/delay pin combined with the Power Good/Power-on-Reset (PG/POR) pin allows multiple outputs to be sequenced in any way on turn-on and turn-off. The RC (Ramp Control™) pin allows the device to be connected to another MIC22700 device to keep the output voltages within a certain delta V on start-up.

Requirements

This board needs a single bench power source adjustable over the input voltage of $2.6V < V_{IN} < 5.5V$ that can provide at least 7A of current. The loads can either be active (electronic load) or passive (resistor) with the ability to dissipate the maximum load power while keeping accessible surfaces ideally $< 70^{\circ}C$.

Precautions

There is no reverse input protection on this board. When connecting the input sources, ensure that the correct polarity is observed.

Under extreme load conditions such as short circuit testing, input transients can be quite large if long test leads are used. In such cases, place a 100μF, 6.3V Tantalum capacitor at the V_{IN} terminals to prevent over voltage damage to the IC.

Ramp Control is a trademark of Micrel, Inc.

Micrel Inc. • 2180 Fortune Drive • San Jose, CA 95131 • USA • tel +1 (408) 944-0800 • fax + 1 (408) 474-1000 • <http://www.micrel.com>

June 2011

M9999-062411-A

Getting Started

1. **Connect V_{IN} supply to the input terminals $+V_{IN}$ and GND.** With the output of this supply disabled, set its voltage to the desired input test voltage ($2.6V < V_{IN} < 5.5V$). This supply voltage should be monitored at the test boards input terminals to allow voltage drops in the test cables (and ammeter if used) to be accounted for. An ammeter can be added inline with the $+V_{IN}$ input terminal to accurately measure input current.
2. **Connect the loads to the output terminals between $+V_O$ and GND.** Again, this output voltage should be monitored by connecting the voltmeter at the $+V_O$ and GND terminals. An ammeter can be added inline with the $+V_O$ terminal of the evaluation board to accurately measure the output current.

Output voltage is set to 1.8V. Output voltage can be changed by selecting the resistor R2.

The resistor divider network for a desired V_{OUT} is given by:

$$R2 = \frac{R1}{\left(\frac{V_{OUT}}{V_{REF}}\right)} - 1$$

where V_{REF} is 0.7V and V_{OUT} is the desired output voltage.

Initially, set the output load to 0A to check that the output is regulating properly prior to loaded tests.

3. **Enable the input supply.** By default, the output voltage is enabled when an input supply of $> 2.5V$ is applied. When this threshold is crossed, the enable pin capacitor (1nF) begins to charge at $1V/\mu s$ until it reaches 1.25V, where switching begins. To test the enable functions of the MIC22700, a test point is provided.

Ordering Information

Part Number	Description
MIC22700YML EV	Evaluation board with the integrated 7A MIC22700 device

Other Features

Enable Delay Input

C6 creates a delay set by an internal 1 μ A source charging to a 1.25V threshold. A switch (Q1) is used from EN pin to ground as shutdown 'SHDN' control. The part will exhibit approximately 1.3 μ s enable delay from 'SHDN' going low to the start of switching. Using a pulse generator with a low impedance output connected to the EN terminal will remove this delay as it defeats the internal 1 μ A source.

RC (Ramp Control™) Capacitor

The MIC22700 has a nominal 1 μ A current source/sink to the RC pin. The startup output voltage waveform tracks the voltage on RC. 100% output voltage is represented by 0.7V on RC. The default capacitor on RC (C7) of 10nF sets the ramp up time to approximately 700 μ s.

Feedback resistors

The output is set nominally at 1.8V. This can be changed by adjusting the upper or lower resistor in the FB potential dividers. It is recommended that R1 or R2 value should be kept <10k to reduce noise susceptibility and offset currents from creating voltage errors. Therefore, choosing R1<10k:

$$R2 = R1 \times V_{REF}/(V_O - V_{REF})$$

where $V_{REF} = 0.7V$.

Power-on-Reset (POR) Delay Time Input

Adding an external capacitor to this Delay pin allows the Power Good delay to be adjusted to perform as a Power-on-Reset (POR). As with the RC pin, this pin has an internal 1 μ A current source and sink. When V_{FB} reaches 90% of its nominal voltage (~630mV) the internal 1 μ A current source charges the capacitor on this pin (C8) to the rising threshold of 1.25V, at this point, PG is asserted high. When the enable pin is set low, POR is asserted low immediately. However, the internal 'Delay' current sink discharges the capacitor (C8) to 1.25V lower than its starting point, at which point, it enables the RC pin 1 μ A current sink to begin discharging capacitor C7.

Power-on-Reset (POR) Output

This is an open drain connection with an on board pull-up resistor (R3) to S_{VIN} . This is only asserted high when the FB pin reaches >90% of its nominal set voltage. This can be used as part of the tracking and sequencing function described in the data sheet.

Evaluation Board Performances

Efficiency @ 1.8V_{OUT}

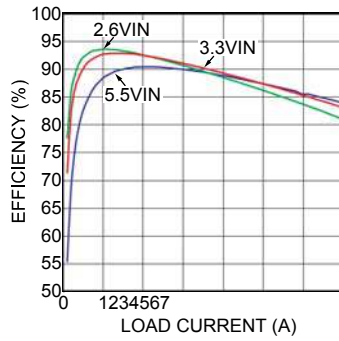

Efficiency @ 3.3V_{OUT}

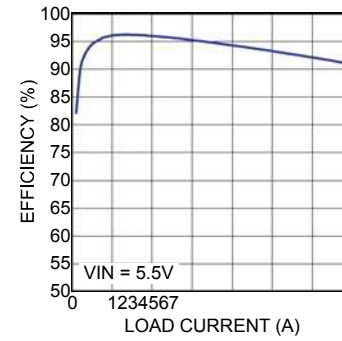

Transient Response
V_{IN} = 5.5V

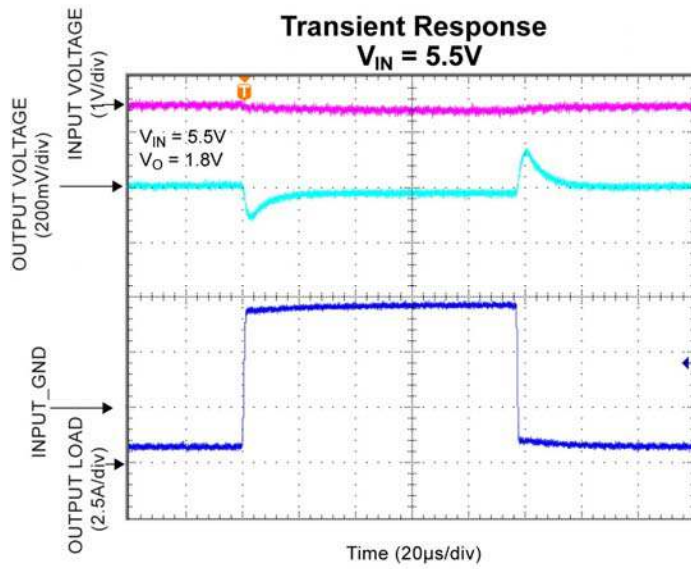

Transient Response
V_{IN} = 5.5V

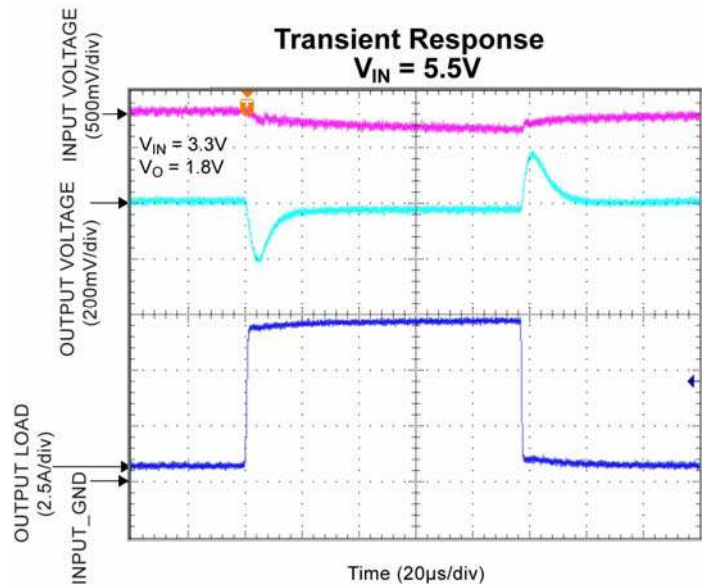

Evaluation Board Schematic

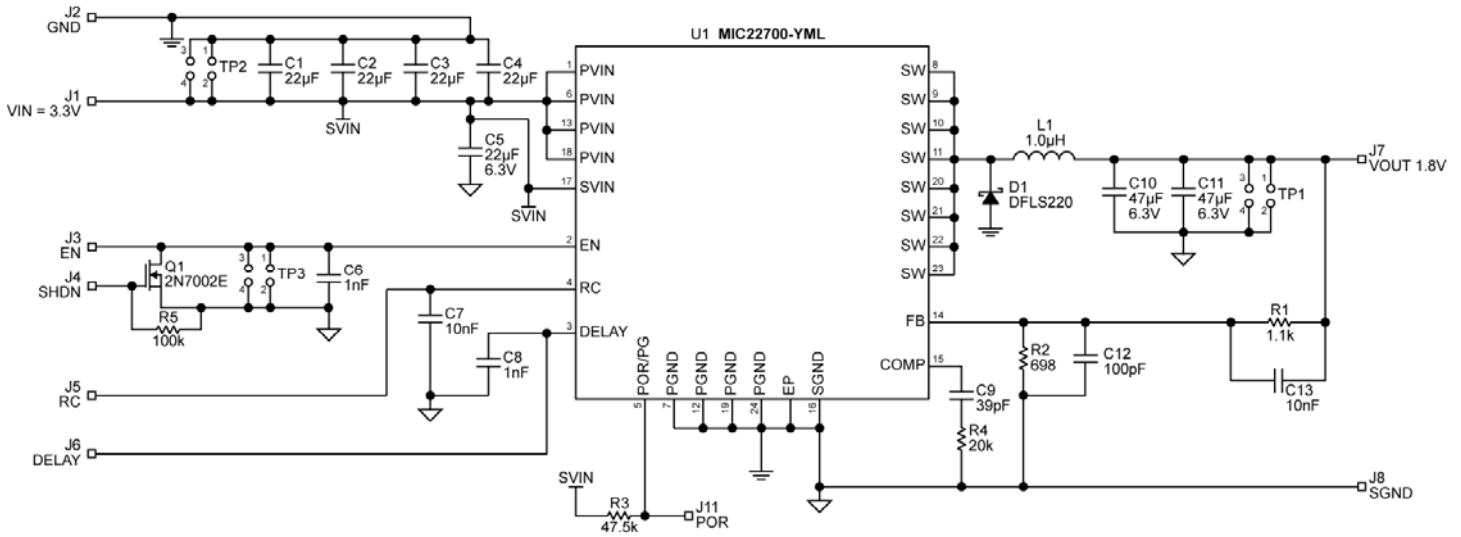

Bill of Materials

Item	Part Number	Manufacturer	Description	Qty.
C1, C2, C3, C4, C5	C2012X5R0J226M	TDK ⁽¹⁾	22µF/6.3V, 0805 Ceramic Capacitor	5
	08056D226MAT	AVX ⁽²⁾		
	GRM21BR60J226ME39L	Murata ⁽³⁾		
C7, C13	GRM188R71H103KA01D	Murata ⁽³⁾	10nF, 0603 Ceramic Capacitor	1
C6	Open (VJ0603Y102KXQCW1BC)	Vishay ⁽⁴⁾	1nF, 0603 Ceramic Capacitor	1
	Open (GRM188R71H102KA01D)	Murata ⁽³⁾	1000pF/50V, X7R, 0603 Ceramic Capacitor	
	Open (C1608C0G1H102J)	TDK ⁽¹⁾	1000pF/50V, COG, 0603 Ceramic Capacitor	
C8	VJ0603Y102KXQCW1BC	Vishay ⁽⁴⁾	1nF, 0603 Ceramic Capacitor	1
	GRM188R71H102KA01D	Murata ⁽³⁾	1000pF/50V, X7R, 0603 Ceramic Capacitor	
	C1608C0G1H102J	TDK ⁽¹⁾	1000pF/50V, COG, 0603 Ceramic Capacitor	
C9	GRM1555C1H390JZ01D	Murata ⁽³⁾	39pF/50V, COG, 0402, Ceramic Capacitor	1
	VJ0402A390KXQCW1BC	BC Components	39pF/10V, 0402, Ceramic Capacitor	
C10, C11	C3216X5R0J476M	TDK ⁽¹⁾	47µF/6.3V, X5R, 1206, Ceramic Capacitor	2
	GRM31CR60J476ME19	Murata ⁽³⁾		
	GRM31CC80G476ME19L	Murata ⁽³⁾		
C12	VJ0402A101KXQCW1BC	Vishay ⁽⁴⁾	100pF, 0603 Ceramic Capacitor	1
	GRM1555C1H101JZ01D	Murata ⁽³⁾	100pF/50V, COG, 0402, Ceramic Capacitor	

Bill of Materials (Continued)

Item	Part Number	Manufacturer	Description	Qty.
D1	SS2P2L	Vishay ⁽⁴⁾	2A, 20V Schottky Diode	1
	DFLS220	Diodes, Inc. ⁽⁵⁾		
L1	SPM6530T-1R0M120	TDK ⁽¹⁾	1 μ H, 12A, size 7mm \times 6.5mm \times 3mm	1
	HCP0704-1R0-R	Coiltronics	1 μ H, 12 A, size 6.8mm \times 6.8mm \times 4.2mm	
R1	CRCW06031101FKEYE3	Vishay ⁽⁴⁾	1.1k, 0603 Resistor, 1%	1
R2	CRCW04026980FKEYE3	Vishay ⁽⁴⁾	698 Ω , 0603 Resistor, 1%	1
R3	CRCW06034752FKEYE3	Vishay ⁽⁴⁾	47.5k, 0603 Resistor, 1%	1
R4	CRCW04022002FKEYE3	Vishay ⁽⁴⁾	20k, 0402 Resistor, 1%	1
R5	Open (CRCW06031003FRT1)	Vishay ⁽⁴⁾	100k, 0603 Resistor, 1%	1
Q1	Open (2N7002E)	Vishay ⁽⁴⁾	Signal MOSFET – SOT-23-6	1
	Open(CMDPM7002A)	Central Semiconductor ⁽⁵⁾		
U1	MIC22700YML	Micrel⁽⁶⁾	Integrated 7A Synchronous Buck Regulator	1

Notes:

1. TDK: www.tdk.com.
2. AVX: www.avx.com.
3. Murata: www.murata.com.
4. Vishay: www.vishay.com.
5. Central Semiconductor: www.centrasemi.com.
6. **Micrel, Inc.:** www.micrel.com.

PCB Layout Recommendations

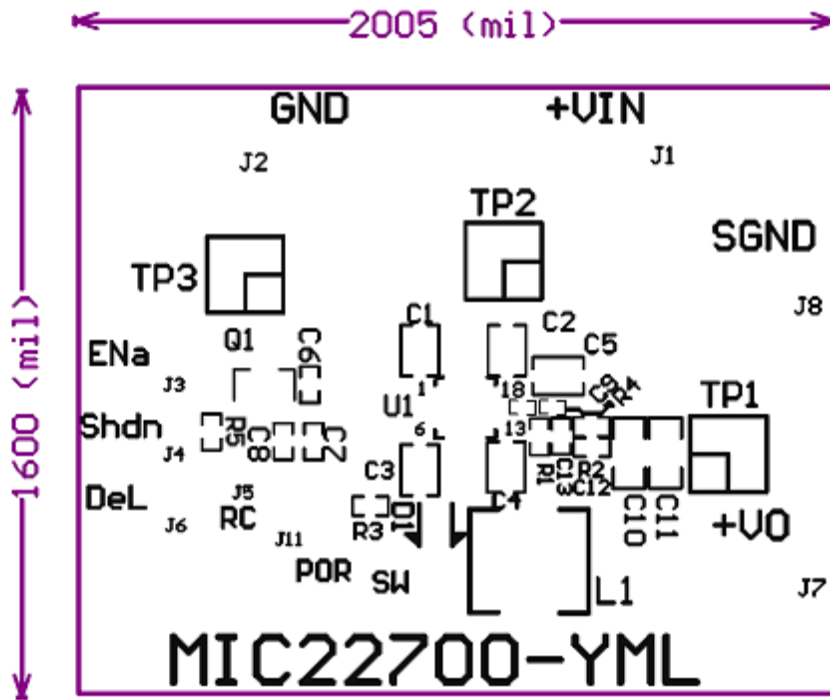

Top Silk

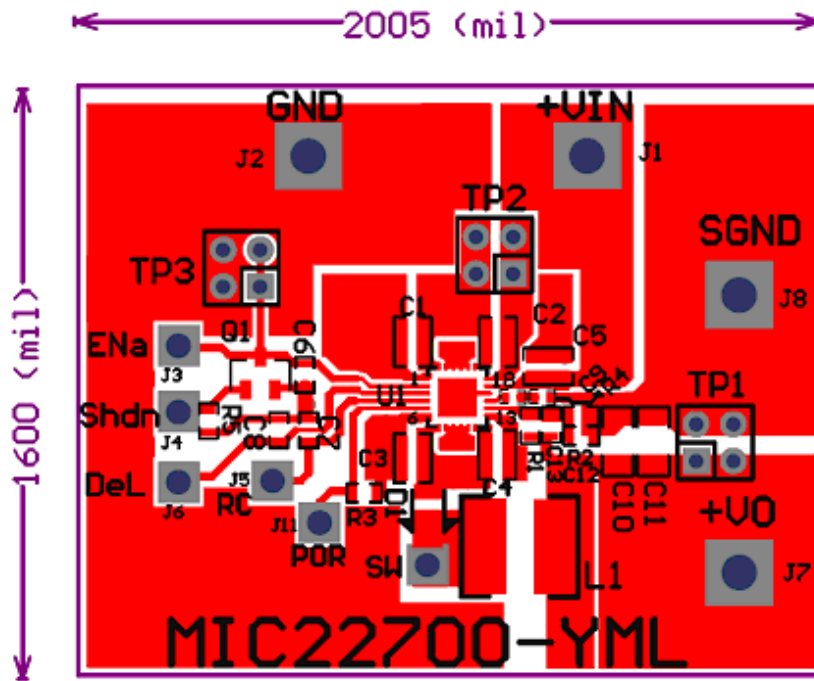

Top Layer

PCB Layout Recommendations (Continued)

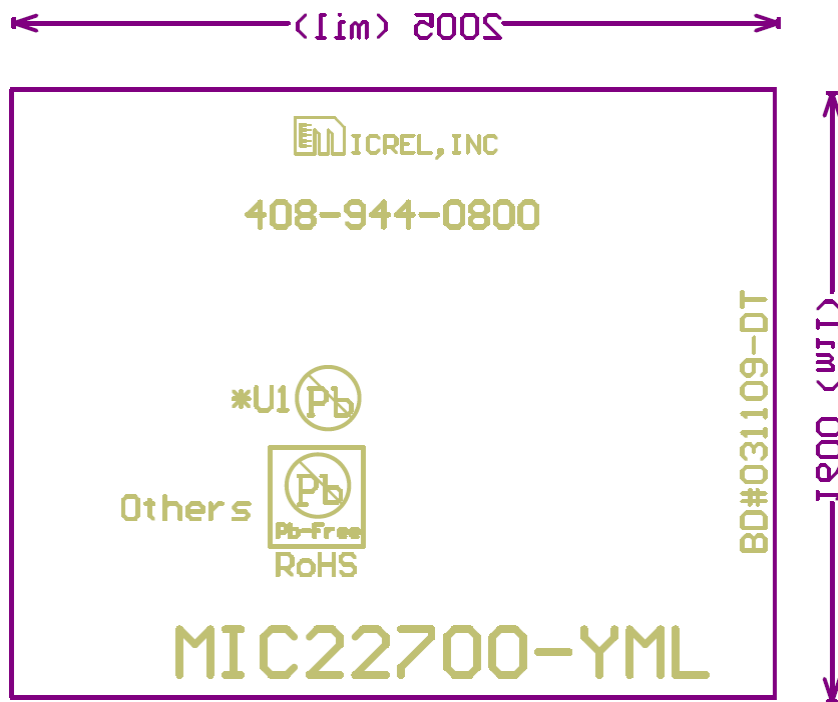

Bottom Silk

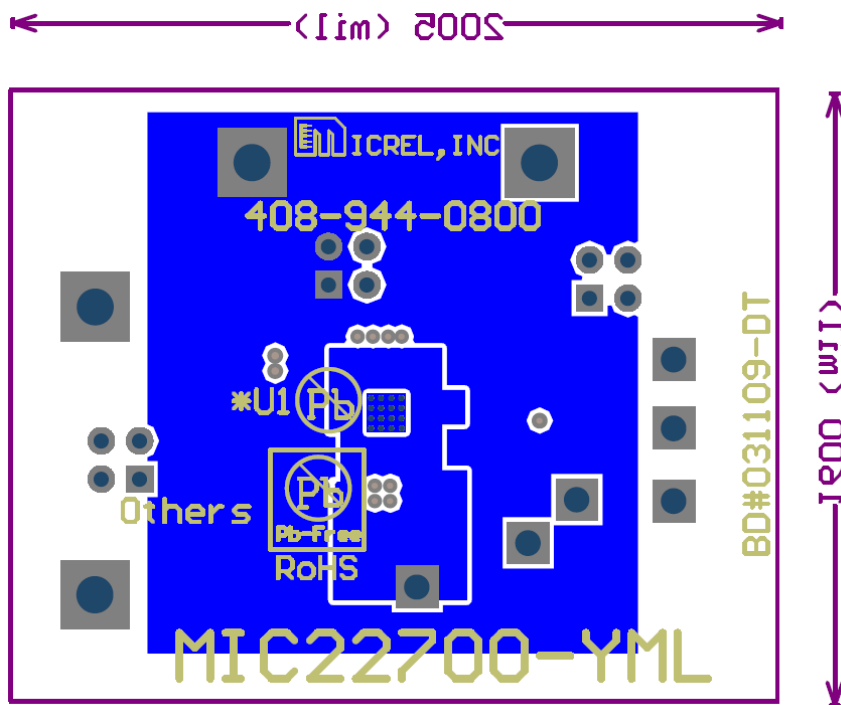

Bottom Layer

MICREL, INC. 2180 FORTUNE DRIVE SAN JOSE, CA 95131 USA
TEL +1 (408) 944-0800 FAX +1 (408) 474-1000 WEB <http://www.micrel.com>

Micrel makes no representations or warranties with respect to the accuracy or completeness of the information furnished in this data sheet. This information is not intended as a warranty and Micrel does not assume responsibility for its use. Micrel reserves the right to change circuitry, specifications and descriptions at any time without notice. No license, whether express, implied, arising by estoppel or otherwise, to any intellectual property rights is granted by this document. Except as provided in Micrel's terms and conditions of sale for such products, Micrel assumes no liability whatsoever, and Micrel disclaims any express or implied warranty relating to the sale and/or use of Micrel products including liability or warranties relating to fitness for a particular purpose, merchantability, or infringement of any patent, copyright or other intellectual property right.

Micrel Products are not designed or authorized for use as components in life support appliances, devices or systems where malfunction of a product can reasonably be expected to result in personal injury. Life support devices or systems are devices or systems that (a) are intended for surgical implant into the body or (b) support or sustain life, and whose failure to perform can be reasonably expected to result in a significant injury to the user. A Purchaser's use or sale of Micrel Products for use in life support appliances, devices or systems is a Purchaser's own risk and Purchaser agrees to fully indemnify Micrel for any damages resulting from such use or sale.

© 2008 Micrel, Incorporated.