

Data Sheet

Description

Avago Technologies AFEM-S102 FEM integrates an SP3T antenna switch, TX Path Coupler and FBAR Co-Existence Filter for applications with IEEE 802.11 b/g/n WiFi and Bluetooth modulation. The FEM exhibits low Insertion Loss and good match while providing high rejection to meet stringent coexistence requirements. It utilizes Avago Technologies proprietary GaAs pHEMT and FBAR filter technology for superior performance across all operating conditions.

The AFEM-S102 is packaged in a 2.2 x 2.2 x 0.55 mm nominal size for space-constrained handset applications.

Applications

- Portable and Handset 802.11 b/g/n WiFi and BT Applications
- Mobile Routers

Functional Block Diagram and Pin-Out

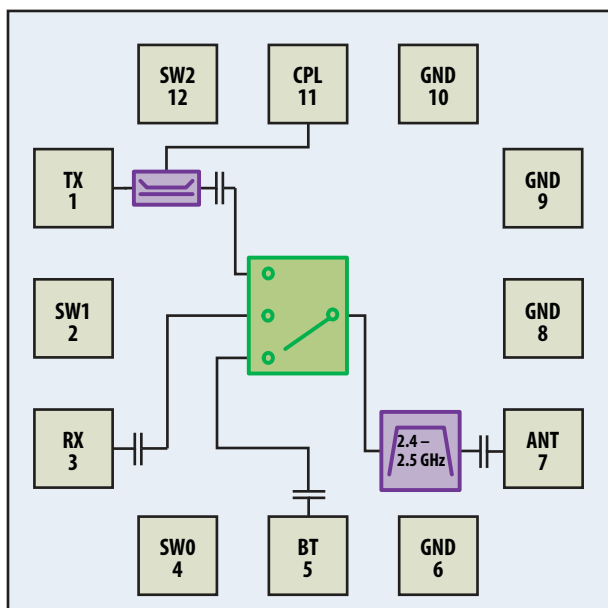

Features

- 50 Ω all RF ports
- TX, RX, BT and ANT ports DC blocked
- Passband 2.4 – 2.5 GHz
- 2.6 dB Max Insertion Loss (TX Path)
- 35 dB Rejection in 2110 - 2170 MHz
- >40 dB TX Path Rejection at 2nd and 3rd Harmonic Bands
- Minimum 29 dB TX - RX Port Isolation
- 2.75 V Minimum Control Voltage for WLAN TX & RX Mode
- 2.45 V Minimum Control Voltage for BT Mode
- <20 μ A Control Pin Current
- -18 dB TX Directional Coupling
- -30° C to +85° C operation

Component Image

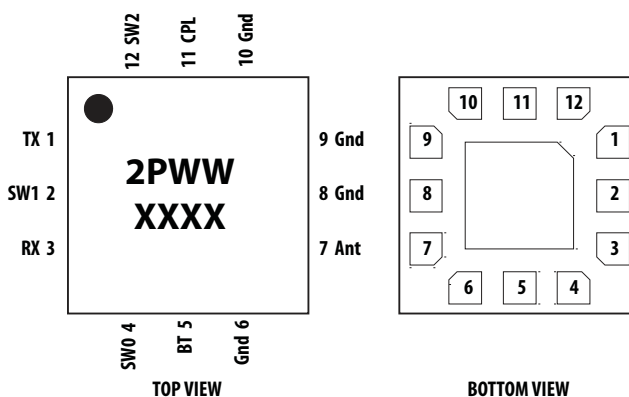

Note:
Package marking provides Orientation and identification
1st row "2P" = Product Code
1st row "WW" = Work Week of manufacture
2nd row "XXXX" = Lot Number

Table 1. Absolute Maximum and Minimum Ratings

Parameter	Performance			Comments
	Min.	Max.	Unit	
Maximum Control Voltage		10	V	All Control Pins
Maximum Input Power (CW)		33	dBm	TX Port
MSL		MSL3		
Storage Temperature	-65	150	°C	
Operation Temperature	-30	85	°C	
ESD (HBM)		300	V	
ESD (MM)		90	V	

Table 2. Recommended Operating Range

Parameter		Performance				Comments	
		Min.	Typical	Max.	Unit		
WiFi Path	Control Voltage	Vhigh	2.75	3.0	6.0	V	SW0, SW1, per control pin
	Control Current	Ihigh			20	μA	
	Control Voltage	Vlow	0		0.1	V	
	Control Current	Ilow			10	μA	
Bluetooth Path	Control Voltage	Vhigh	2.45	3.0	6.0	V	SW2 only
	Control Current	Ihigh			20	μA	
	Control Voltage	Vlow	0		0.1	V	
	Control Current	Ilow			10	μA	
Case Temperature			-30		85	°C	
RF Input Power	TX Path				24	dBm	

Table 3. RF Electrical Characteristics

All data measured on an FR4 demo board at Tc = 25°C, 50 Ω at all ports. Unless otherwise specified, all data is taken with CW signal

Parameter		Performance				Comments
		Min.	Typical	Max.	Unit	
Pass-Band Frequency Range		2403		2493	MHz	
Return Loss		10			dB	All RF ports
Average Insertion Loss Over 18 MHz Bandwidth Ch 1 – 13	RX – ANT	25° C	2.1	2.5	dB	* Ch 14 IL 2.6dB
		85° C		2.9		85° C Performance Guaranteed by Design
	TX – ANT	25° C	2.1	2.6	dB	* Ch 14 IL 2.7dB
		85° C		3		85° C Performance Guaranteed by Design
BT Path Insertion Loss (2402 – 2480 MHz)	BT – ANT	25° C	1.8	2.7	dB	
		85° C		3		85° C Performance Guaranteed by Design

Table 3. RF Electrical Characteristics (cont.)

Parameter		Performance			Unit	Comments
		Min.	Typical	Max.		
Insertion Loss Ripple	All Paths			0.6	dB	Across 18 MHz BW
Isolation	TX – RX	29	31		dB	
	TX – BT	23	27			
Switching Time	TX, RX, BT Path Turn – On		120	200	ns	
	TX, RX, BT Path Turn – Off		150	250		
Out-of-Band Rejection	875 – 960 MHz	35	37		dB	Band-5/6 and 8 RX
	1477 – 1501 MHz	33	35			
TX & RX Paths	1574 – 1577 MHz	33	35			GPS Band
	1805 – 1880 MHz	33	35			Band 3 RX
	1930 – 1990 MHz	34	35			PCS Band RX
	2110 – 2170 MHz	34	35			Band 1 RX
	4900 – 5805 MHz		50			2 nd Harmonic (TX Path)
	7200 – 7500 MHz		40			3 rd Harmonic (TX Path)
Out-of-Band Rejection	875 – 960 MHz	34.5			dB	Band-5/6 and 8 RX
	1477 – 1501 MHz	32	33			
BT Path	1574 – 1577 MHz	31	33			GPS Band
	1805 – 1880 MHz	32	33			Band 3 RX
	1930 – 1990 MHz	33	35			PCS Band RX
	2110 – 2170 MHz	34	35			Band 1 RX
	4900 – 5805 MHz		40			2 nd Harmonic
	7200 – 7500 MHz		28			3 rd Harmonic
Group Delay	All Paths			15	ns	2.4 – 2.5 GHz
Group Delay Variation				6		Across and 20 MHz Band
Directional Coupler	Coupling	17.5	18	19.5	dB	
	Directivity	10.5	12			
TX Path Harmonic Distortion	2 nd Harmonic			-50.1	dBm	With CW Excitation (Pout = 22.5 dBm)
	3 rd Harmonic			-60.9		
	4 th Harmonic			-47.3		
OIP3	WLAN TX	43			dBm	Tone1: 2418 MHz; Tone2: 2432 MHz, Ptone: 12 dBm;
	BT	38				
Input P1dB	TX Path	31			dBm	With CW Excitation

Table 4. Truth Table

State	SW0	SW1	SW2
RX – ANT	High	Low	Low
TX – ANT	Low	High	Low
BT – ANT	Low	Low	High

Pre-released products: Avago Technologies reserves the right to alter specifications, features, functions, markings, manufacturing release dates and general availability of the product at any time.

Performance Plots (All data measured at $T_c = 25^\circ\text{C}$, $50\ \Omega$ at all ports)

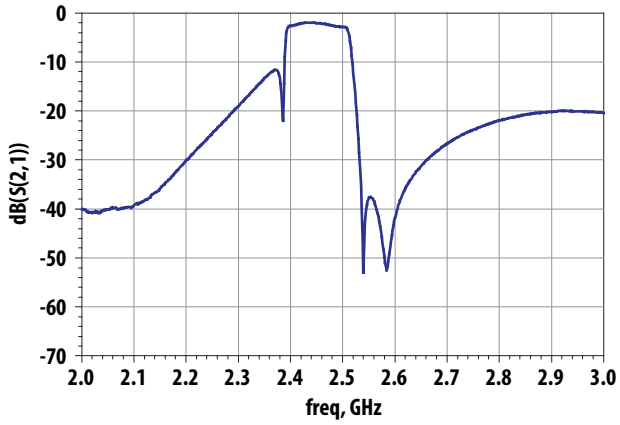

Figure 1. TX Path 2 – 3 GHz Frequency Response

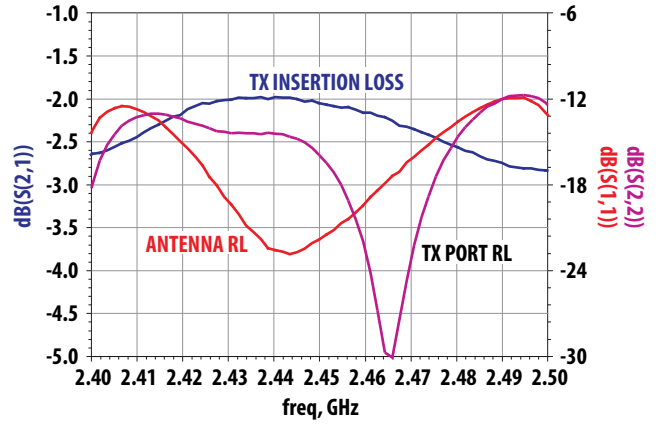

Figure 2. TX Path 2.4 – 2.5 GHz Insertion Loss and Return Loss

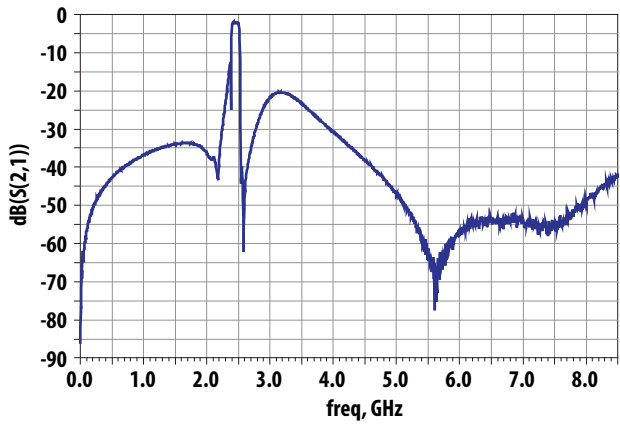

Figure 3. TX Path 0 – 8.5 GHz Frequency Response



Figure 4. RX Path 2 – 3 GHz Frequency Response

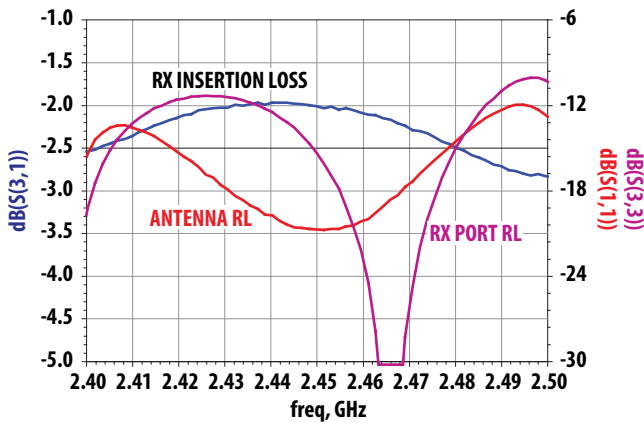

Figure 5. RX Path 2.4 – 2.5 GHz Insertion Loss and Return Loss

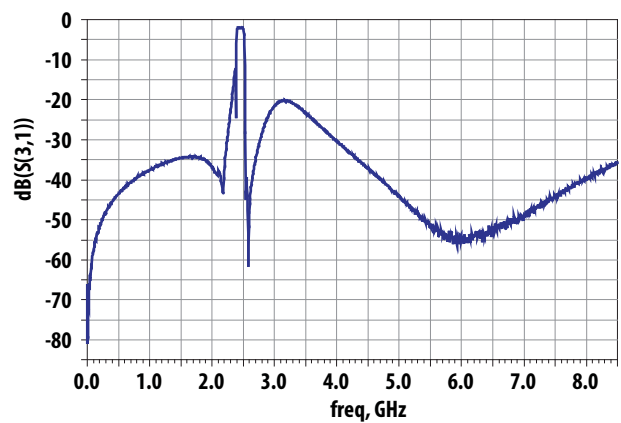

Figure 6. RX Path 0 – 8.5 GHz Frequency Response

Performance Plots (All data measured at $T_c = 25^\circ\text{C}$, $50\ \Omega$ at all ports) (cont.)

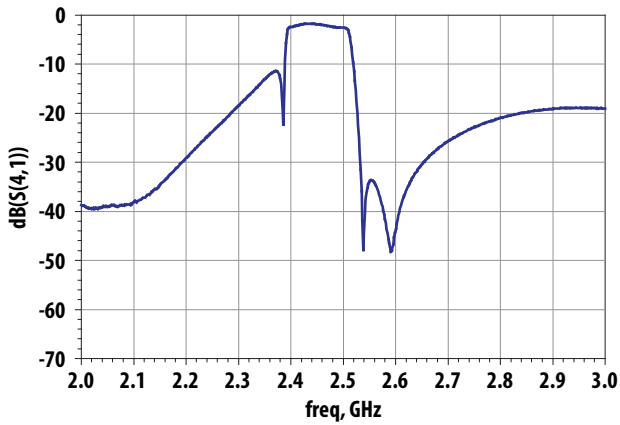

Figure 7. BT Path 2 – 3 GHz Frequency Response

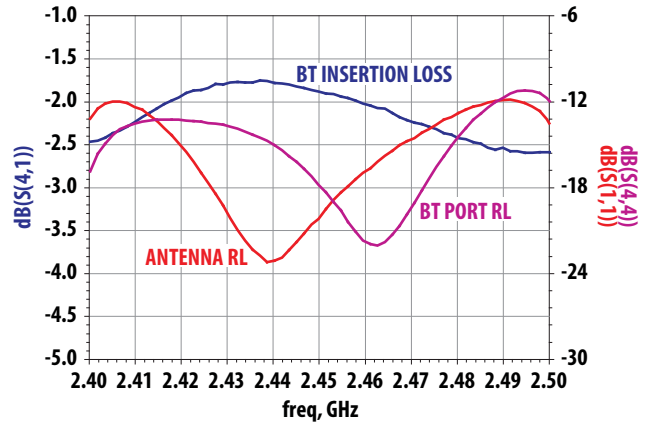

Figure 8. BT Path 2.4 – 2.5 GHz Insertion Loss and Return Loss

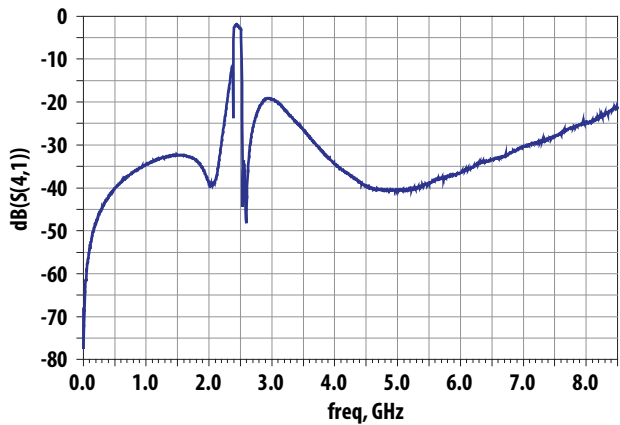

Figure 9. BT Path 0 – 8.5 GHz Frequency Response

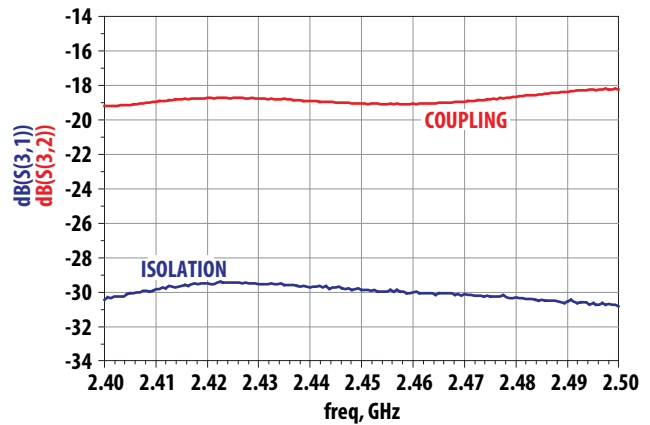

Figure 10. TX Coupling Coefficient and Coupler Isolation vs Frequency

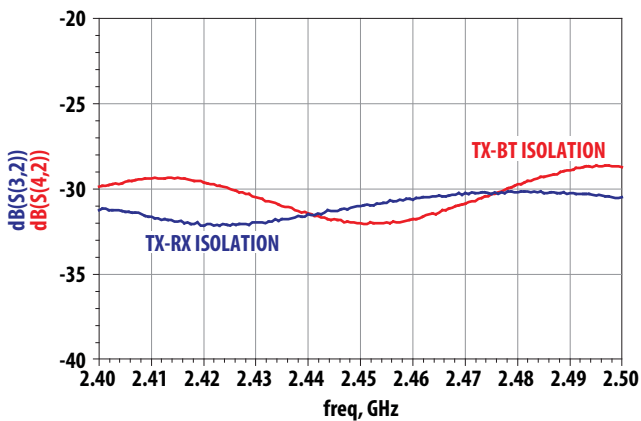

Figure 11. TX-RX and TX-BT Isolation in 2.4 – 2.5 GHz Band

Performance Plots (All data measured at $T_c = 25^\circ\text{C}$, $50\ \Omega$ at all ports) (cont.)

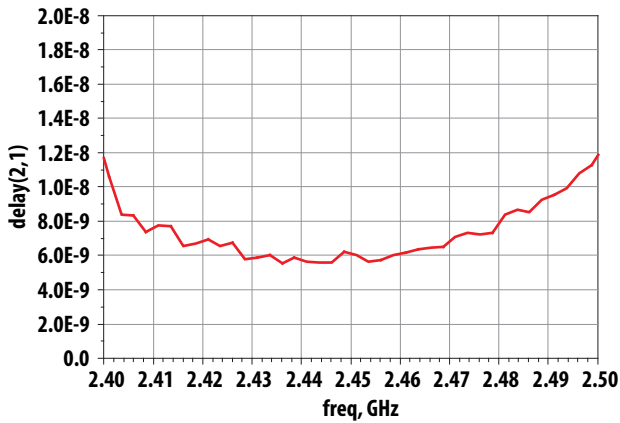

Figure 12. Typical Group Delay vs Frequency Response (TX Path)

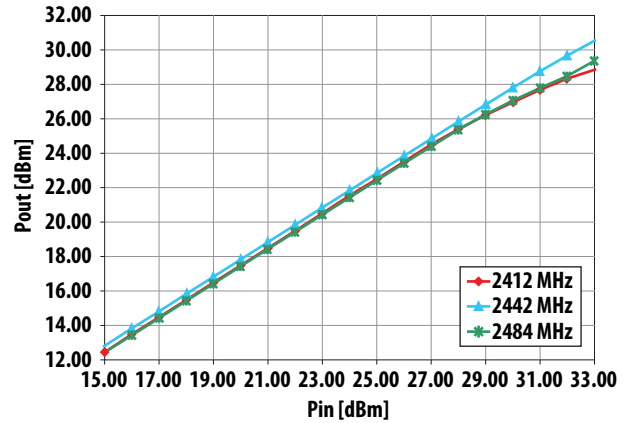
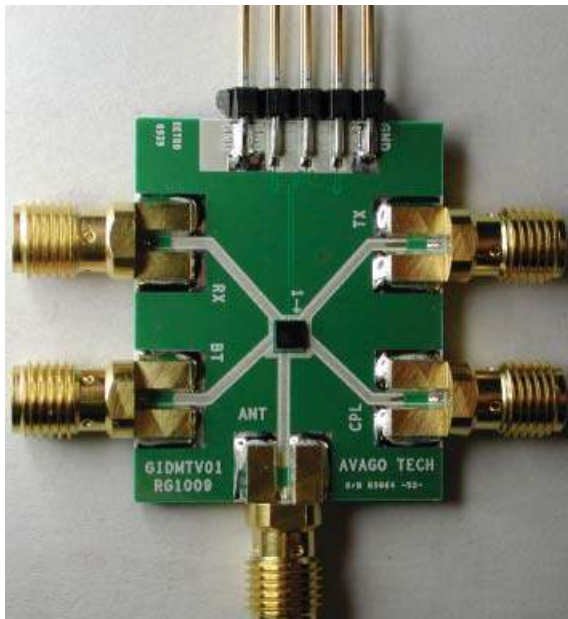

Figure 13. Typical Pout vs Pin Curve – P1dB = 31 dBm (TX Path)

Demoboard Description

AFEM-S102 has a demonstration board with five SMA connectors all RF ports. A DC connector is used for switch control signals SW0, SW1 & SW2.



Evaluation Board Schematic

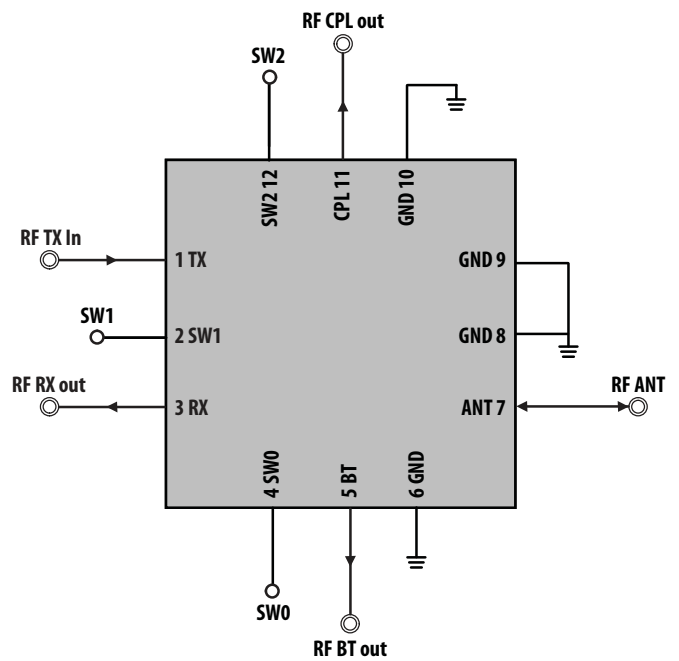

Note: No external SMTs required.

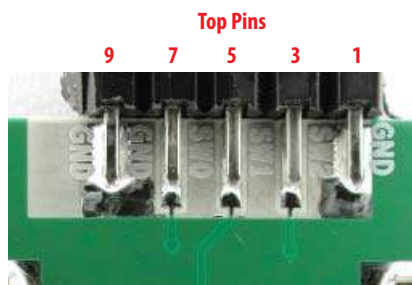

Top Pin No.	Function
1	GND
3	SW2
5	SW1
7	SW0
9	GND

All Bottom Pins are connected to GND.

Package Dimensions and Pin Descriptions

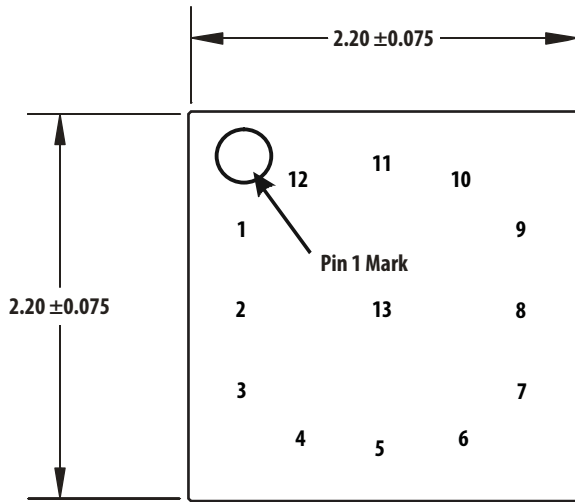

Top View

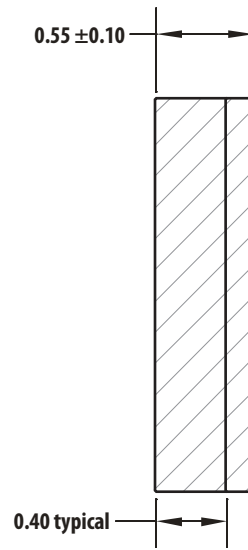

Side View

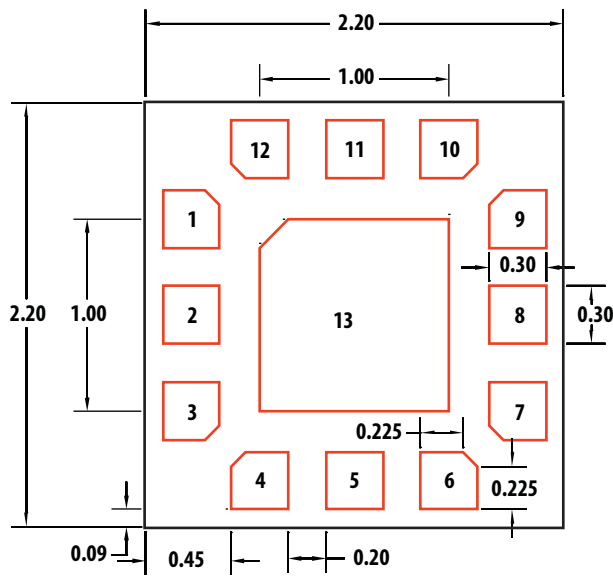

Top View Through Package

Pin Description

Pin #	Name	Description
1	TX	RF Transmit
2	SW1	Control Voltage
3	RX	RF Receive
4	SW0	Control Voltage
5	BT	RF Bluetooth
6	GND	Ground
7	ANT	RF Antenna
8	GND	Ground
9	GND	Ground
10	GND	Ground
11	CPL	RF TX Coupled
12	SW2	Control Voltage
13	GND	Ground

Reflow Profile Recommendations

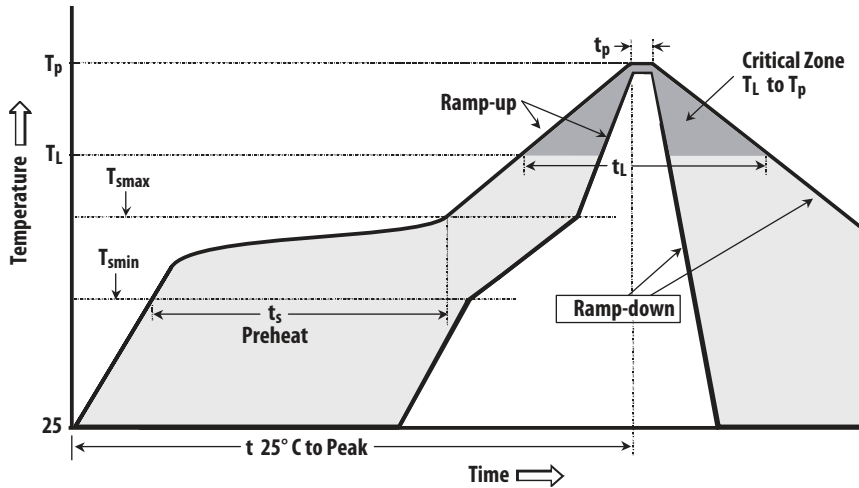

Typical SMT Reflow Profile for Maximum Temperature = $260 \pm 0/-5^\circ\text{C}$

Typical SMT Reflow Profile for Maximum Temperature = $260 \pm 0/-5^\circ\text{C}$

Profile Feature	Sn-Pb Solder	Pb-Free Solder
Average ramp-up rate (TL to TP)	3°C/sec max	3°C/sec max
Preheat		
– Temperature Min (T _{smin})	100° C	150° C
– Temperature Max (T _{smax})	150° C	200° C
– Time (min to max) (t _s)	60-120 sec	60-120 sec
T _{smax} to TL		
– Ramp-up Rate		3°C/sec max
Time maintained above:		
– Temperature (TL)	183° C	217° C
– Time (TL)	60-150 sec	60-150 sec
Peak temperature (T _p)	240 $\pm 0/-5^\circ\text{C}$	260 $\pm 0/-5^\circ\text{C}$
Time within 5° C of actual Peak Temperature (t _p)	10-30 sec	20-40 sec
Ramp-down Rate	6°C/sec max	6°C/sec max
Time 25° C to Peak Temperature	6 min max.	8 min max.

Device Orientation & Pin 1 Location In Tape

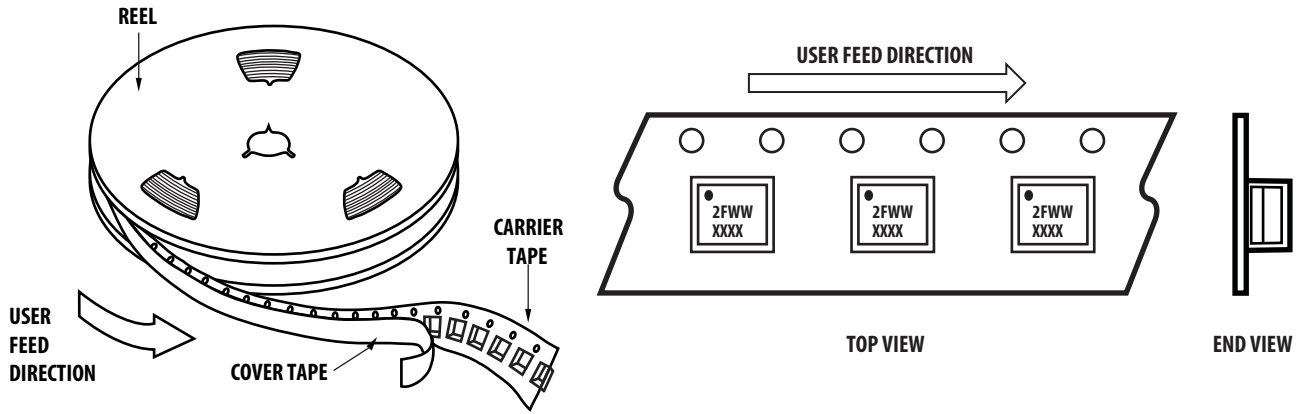

Tape Dimensions

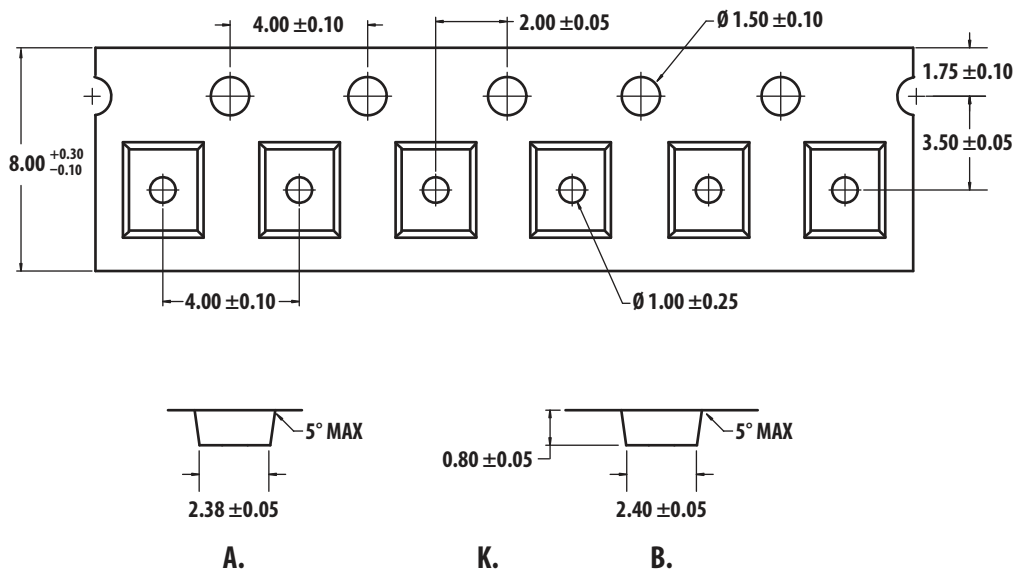

Reel Information

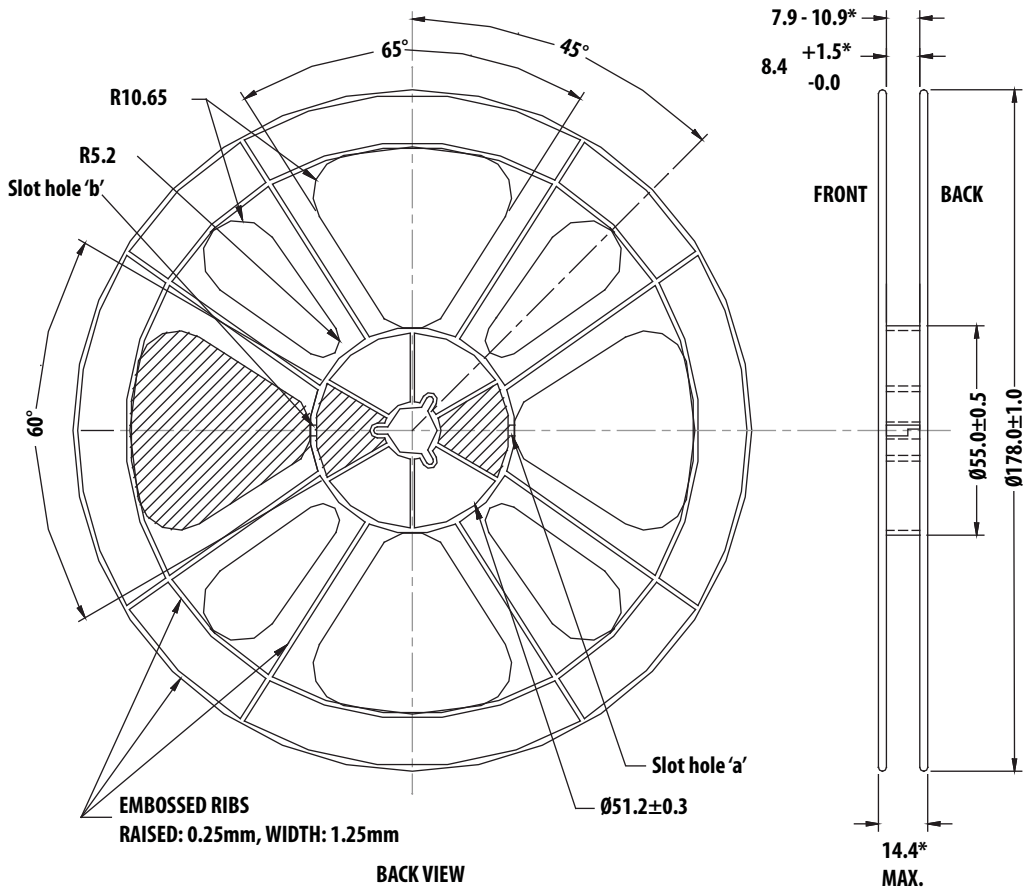
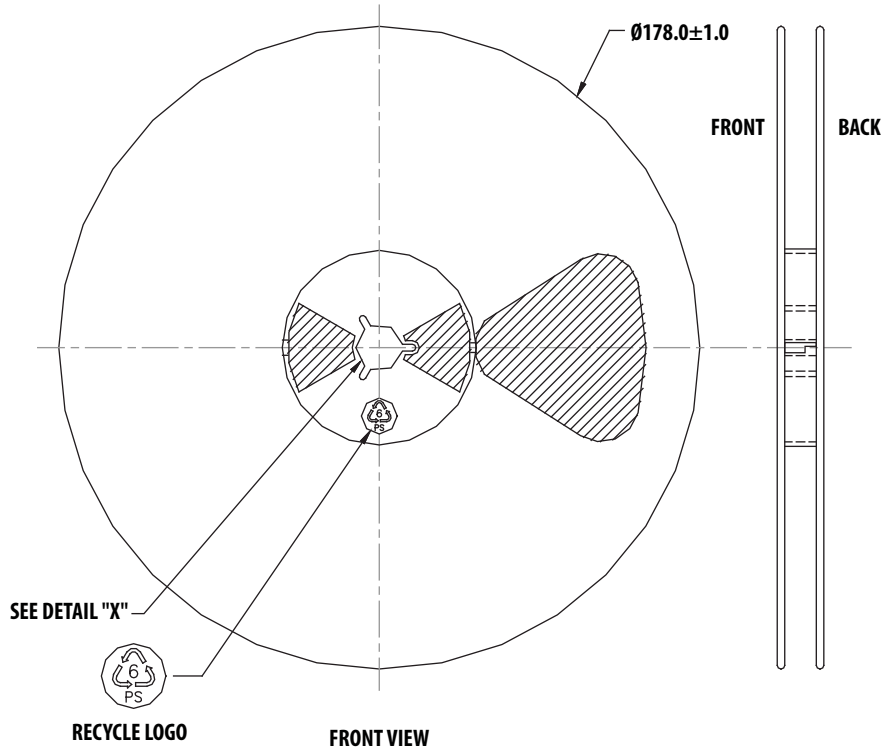

AFEM-S102 Part Number Ordering Information

Part Number	Devices Per Container	Container
AFEM-S102-BLKG	100	Antistatic bag
AFEM-S102-TR1G	3000	7" Reel

For product information and a complete list of distributors, please go to our web site: www.avagotech.com

Avago, Avago Technologies, and the A logo are trademarks of Avago Technologies in the United States and other countries. Data subject to change. Copyright © 2005-2012 Avago Technologies. All rights reserved.
AV02-2882EN - February 27, 2012

