



SPECIFICATIONS

Model	Max Torque	Max Reverse Torque	Max Angle
FHD-A1-2-104	10Nm (100 kgf•cm)	1Nm or lower (10 kgf•cm or lower)	120°

Main Body Material	Hinge Material	Oil Type	Operating Temp. C°	Mass g
Zinc die-cast (ZDC) + silver coating	SUS304	Silicone oil	-5~50	410

HOW TO USE THE DAMPER

- There are two ways to attach the damper, as shown below.
- Attached externally (FHD-A1-1***)

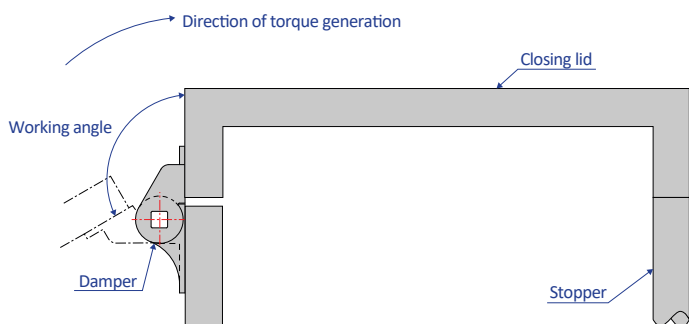

- Attached externally (FHD-A1-2***)

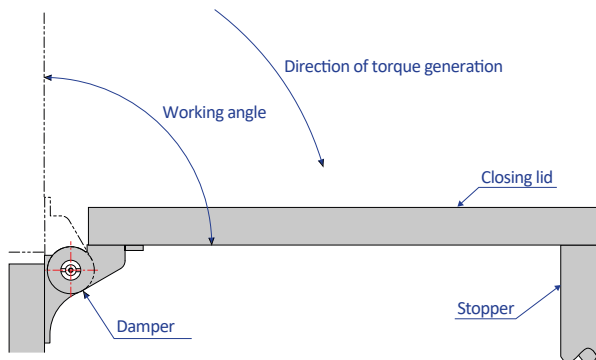

- This damper is only for horizontal application. Please do not use this damper for vertical application.

DAMPER CHARACTERISTICS

- Temperature characteristics
- Damper characteristics vary according to the ambient temperature. In general, the damper characteristics become weaker as the temperature increases, and become stronger as the temperature decreases. This is because the viscosity of the oil inside the damper varies according to the temperature. When the temperature returns to normal, the damper characteristics will return to normal as well.

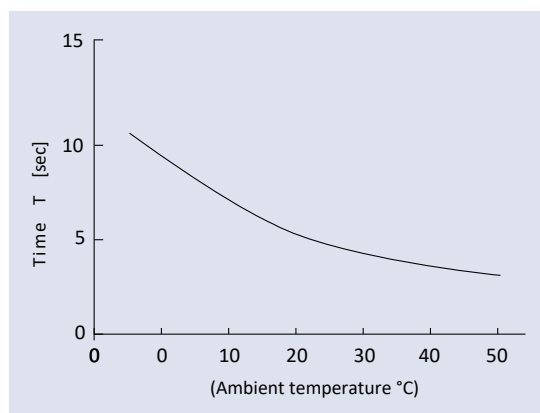

- The working angle of the hinge is 120°. Operating the hinge beyond this angle will cause damage to the hinge. Please ensure that an external stopper is in place.