

CBTL05024

High performance multiplexer/demultiplexer switch for Thunderbolt applications

Rev. 4 — 27 March 2014

Product data sheet

1. General description

The CBTL05024 is a multiplexer/demultiplexer switch chip optimized to interface the Thunderbolt/MiniDP connector with Thunderbolt systems. It supports 10.3125 Gbit/s Thunderbolt or DisplayPort v1.2 channels.

The TB MUX is a 3 : 1 switch that selects between Thunderbolt data path and DisplayPort v1.2 side-band signals — either DDC or AUX.

The DP MUX is a 2 : 1 switch that selects between DP ML (DisplayPort Main Link) and LS TX/RX signals. Both LSTX and LSRX are the side-band signals for Thunderbolt channel.

This chip also includes HPD and CA_DET buffers for HPD_IN and CA_DET control signals.

CBTL05024 is powered by a 3.3 V supply and it is available in a 3 mm × 3 mm HVQFN24 package with 0.4 mm pitch.

2. Features and benefits

2.1 TB MUX 3 : 1 switch

- This 3 : 1 switch is implemented by two cascaded 2 : 1 switches
 - ◆ The first 2 : 1 10G MUX is controlled by TB_ENA, AUXIO_EN and DP_PD pins
 - ◆ The second 2 : 1 AUX MUX is controlled by CA_DET signal multiplexing of the 720 Mbit/s Differential FAUX (or 1 Mbit/s AUX) and DDC (Direct Display Control) signals
 - ◆ When CA_DET is HIGH, DDC path is selected
- Differential TB channel
 - ◆ Low insertion loss: -1.3 dB at 5 GHz
 - ◆ Low return loss: < -20 dB at 5 GHz
 - ◆ Low ON-state resistance: 8 Ω
 - ◆ Bandwidth: 10 GHz
 - ◆ Low off-state isolation: -20 dB at 5 GHz
 - ◆ Low crosstalk: -36 dB at 5 GHz
 - ◆ Differential input voltage V_{ID} : 1.2 V (maximum)
- Differential AUX channel
 - ◆ Low insertion loss: -1.1 dB at 5 MHz; -1.8 dB at 360 MHz
 - ◆ Low return loss: -18 dB at 5 MHz; -16 dB at 360 MHz



- ◆ Low ON-state resistance: 13 Ω (typical); 16 Ω (maximum)
- ◆ Bandwidth: 3 GHz
- ◆ Low off-state isolation: -80 dB at 5 MHz; -55 dB at 360 MHz
- ◆ Low crosstalk: -26 dB at 2.7 GHz
- ◆ Common-mode input voltage V_{IC} : 0 V to 3.3 V
- ◆ Differential input voltage V_{ID} : 1.4 V (maximum)
- DDC channel
 - ◆ ON-state resistor: 50 Ω (maximum)
 - ◆ 100 kHz 3.3 V voltage swing signal
- Both AUXIO+ and AUXIO- outputs have 85 k Ω (± 20 %) resistors
 - ◆ The 85 k Ω AUXIO- pull-up resistor
 - ◆ The 85 k Ω AUXIO+ pull-down resistor is always present

2.2 DP MUX 2 : 1 switch

- Multiplexes between differential DP ML signal and LSTX/LSRX signals
- The DP ML (DisplayPort Main Link) runs up to HBR2 data rate of 5.4 Gbit/s
- The low speed DC-coupled signals LSTX and LSRX are 3.3 V single-ended signals that operate at 1 Mbit/s
- 5.4 Gbit/s DP-DPMLO path for DP MUX
 - ◆ Low insertion loss for DP-DPMLO path: -1.2 dB at 2.7 GHz
 - ◆ Low return loss for DP-DPMLO path: -15 dB at 2.7 GHz
 - ◆ Low ON-state resistance for DP-DPMLO path: 9 Ω
 - ◆ High bandwidth: 5.5 GHz
 - ◆ Low off-state isolation: -20 dB at 2.7 GHz
 - ◆ Low crosstalk: -25 dB at 2.7 GHz
 - ◆ Common-mode input voltage V_{IC} : 0 V to 3.3 V
 - ◆ Differential input voltage V_{ID} : 1.4 V (maximum)
- LS-DPMLO path for DP MUX
 - ◆ Low insertion loss: single-ended insertion loss (ON) is -1.0 dB at 5 MHz
 - ◆ Low return loss: single-ended return loss (ON) is -20 dB at 5 MHz
 - ◆ Low ON-state resistance: 16 Ω (typical) for $V_{DD} = 3.3$ V
 - ◆ High bandwidth: Single-ended -3 dB bandwidth is 1 GHz
 - ◆ Low off-state isolation: single-ended insertion loss (OFF) is -60 dB at 5 MHz
 - ◆ Low crosstalk: -40 dB at 5 GHz

2.3 General

- The input of the HPD (Hot Plug Detect) buffer is 5 V tolerant
- HPDOOUT and CA_DETOUT buffers
 - ◆ CA_DET input leakage current < 0.1 μ A to prevent driving the 1 M Ω pull-down to a HIGH level
- Integrated LSRX buffer with 1 M Ω pull-down resistor (R1) on the LSRX buffer input
- Integrated 8.75 k Ω pull-up resistor (R4) on the LSTX pin

- When AUXIO_EN = 1, TB_ENA = 0 and DP_PD = 1, the CBTL05024 is in Detect mode
 - ◆ AUXIO+ and AUXIO– of the TB MUX are disabled
 - ◆ LS path is selected in DP MUX
 - ◆ CA_DET and HPD buffers are on
 - ◆ When the CBTL05024 is in Detect mode, this chip consumes < 18 μ W
- Patent-pending high bandwidth analog pass-gate technology
- Very low intra-pair differential skew (5 ps typical)
- Back current protection on connector pins (AUXIO+/-, DPMLO+/-, CA_DET and HPD pins)
- All channels support rail-to-rail input voltage
- All CMOS input buffer with hysteresis
- Single 3.3 V \pm 10 % power supply
- HVQFN24 3 mm \times 3 mm package, 0.4 mm pitch, exposed center pad for thermal relief and electrical ground
- ESD: 2000 V HBM, 1000 V CDM
- Operating temperature range -20 °C to 85 °C

3. Ordering information

Table 1. Ordering information

Type number	Topside marking	Package		
		Name	Description	Version
CBTL05024BS	024	HVQFN24	plastic thermal enhanced very thin quad flat package; no leads; 24 terminals; body 3 \times 3 \times 0.85 mm ^[1]	SOT905-1

[1] Maximum package height is 1 mm.

3.1 Ordering options

Table 2. Ordering options

Type number	Orderable part number	Package	Packing method	Minimum order quantity	Temperature
CBTL05024BS	CBTL05024BSHP	HVQFN24	Reel 13" Q2/T3 *standard mark SMD	6000	T _{amb} = -20 °C to $+85$ °C

4. Block diagram

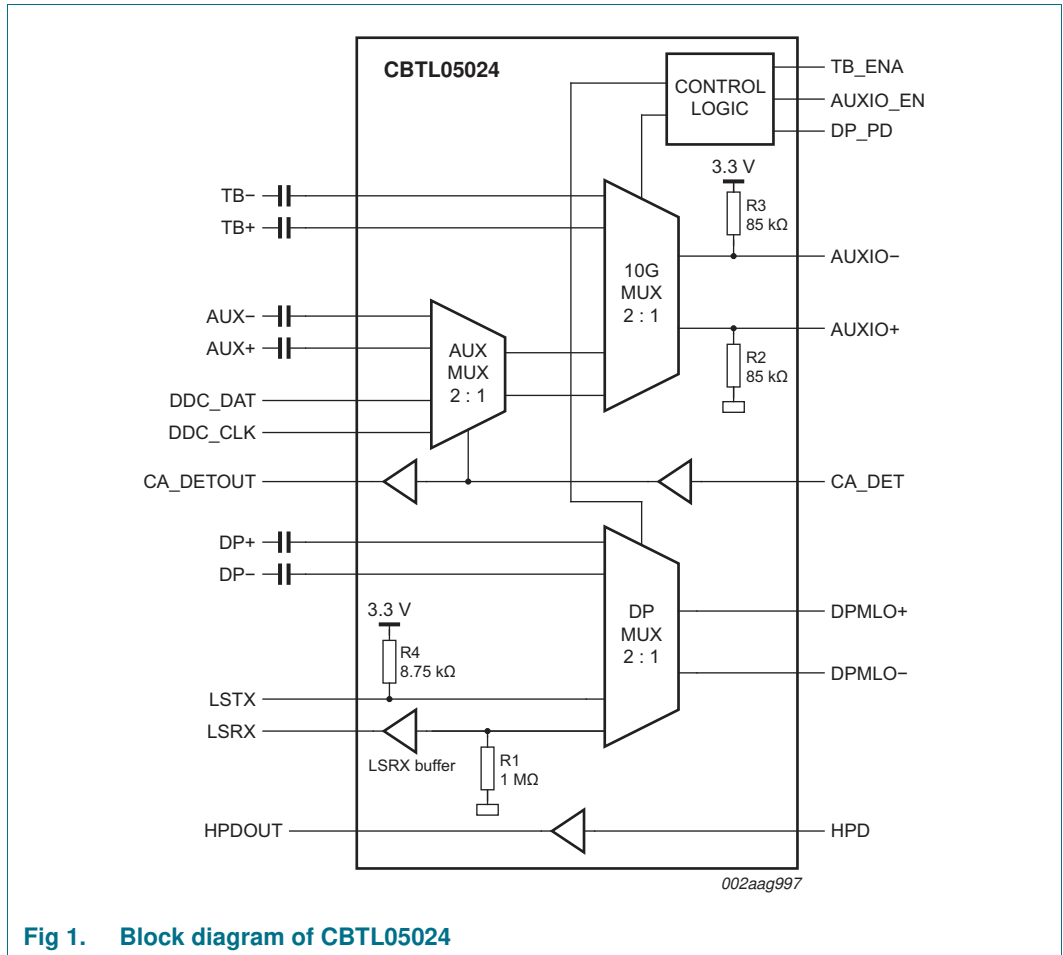
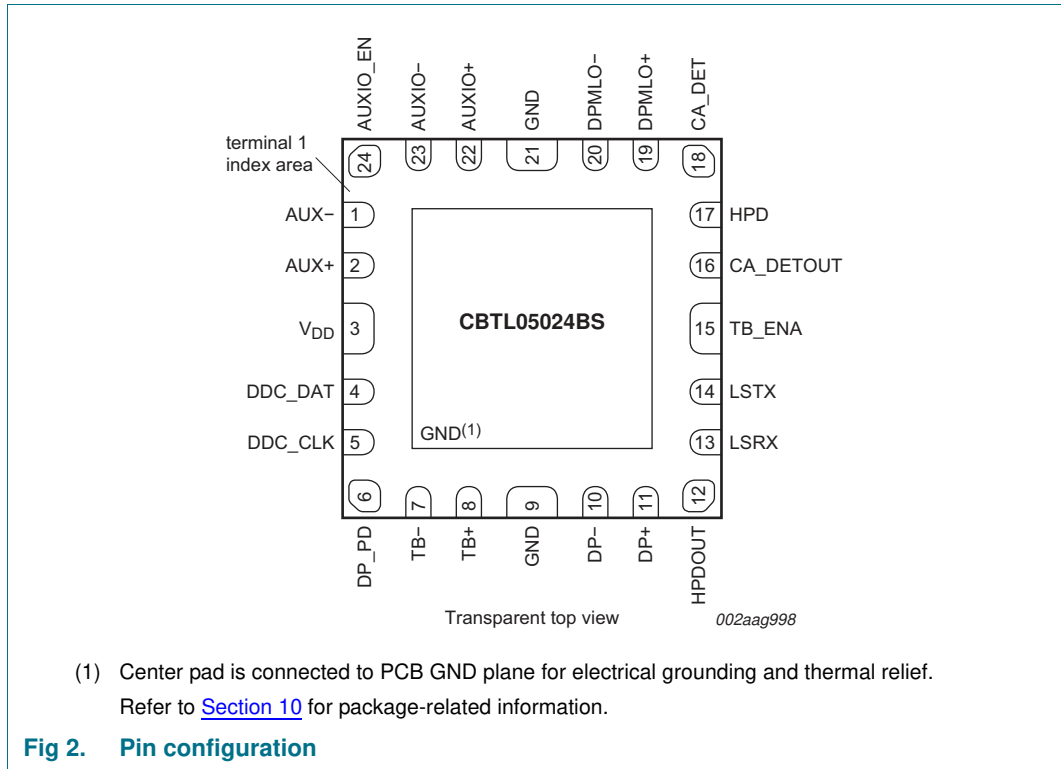

Fig 1. Block diagram of CBTL05024

5. Pinning information

5.1 Pinning



5.2 Pin description

Table 3. Pin description

Symbol	Pin	Type	Description
Data path signals			
AUX-	1	differential I/O	AUX differential signals. The input to this pin must be AC-coupled externally.
AUX+	2	differential I/O	
TB-	7	differential I/O	Thunderbolt differential signals. These output signals must be AC-coupled externally.
TB+	8	differential I/O	
AUXIO-	23	differential I/O	Differential signals for TB MUX.
AUXIO+	22	differential I/O	
DDC_CLK	5	single-ended I/O	Pair of single-ended terminals for DDC clock and data signals.
DDC_DAT	4	single-ended I/O	
DP-	10	differential I/O	High-speed differential pair. The input to this pin must be AC-coupled externally.
DP+	11	differential I/O	
DPMLO-	20	differential I/O	Differential signals for DP MUX.
DPMLO+	19	differential I/O	
LSRX	13	single-ended output	Single-ended TB low speed receive signal.
LSTX	14	single-ended I/O	Single-ended TB low speed transmit signal.
Control signals			
HPDOUT	12	CMOS output	Output buffer for HPD.
HPD	17	CMOS input	HPD input with 5 V tolerance.
CA_DET	18	CMOS input	When CA_DET = HIGH, DDC_CLK and DDC_DAT is selected. When CA_DET = LOW, AUX path is selected.
CA_DETOUT	16	CMOS output	3.3 V CMOS output buffer for CA_DET.
TB_ENA	15	CMOS input	The control input signal to enable Thunderbolt path for TB MUX.
AUXIO_EN	24	CMOS input	The control signal for TB MUX.
DP_PD	6	CMOS input	The control signal for DP MUX. This MUX must work during initial power-up that might have $V_{DD} = 2.3$ V.
3.3 V supply option			
V_{DD}	3	Power	3.3 V supply. Pin 3 must be connected to system power supply.
Ground connections			
GND	9, 21	Ground	Supply ground (0 V).
GND	center pad	Ground	The center pad must be connected to GND plane for both electrical grounding and thermal relief.

6. Functional description

Refer to [Figure 1 “Block diagram of CBTL05024”](#).

The following sections describe the individual block functions and capabilities of the device in more detail.

6.1 Buffer function tables

Table 4. HPD buffer

HPD input	HPDOUT output
0	0
1	1

Table 5. CA_DET buffer

CA_DET input	CA_DETOUT output
0	0
1	1

6.2 AUX MUX function table

Table 6. 2 : 1 AUX MUX function

CA_DET input	AUXIO
0	AUX
1	DDC

6.3 Operation modes of both DPML MUX and TB MUX

Table 7. Operation modes

AUXIO_EN	TB_ENA	DP_PD	CA_DET	AUXIO	DPML0	Modes	R3	R2
0	X	0	X	3-state	3-state	DP Standby mode	ON	ON
0	X	1	X	3-state	LS	Standby mode	ON	ON
1	0	0	0	AUX input	DP input	DP mode	ON	ON
1	0	0	1	DDC	DP input	DP++ mode	ON	ON
1	0	1	X	3-state	LS	Detect mode	ON	ON
1	1	0	1	TB	DP input	Test mode ^[1]	OFF	ON
1	1	0	0	3-state	3-state	Sleep mode	OFF	ON
1	1	1	X	TB	LS	TB mode	OFF	ON

[1] HPD must be LOW during Test mode.

7. Limiting values

Table 8. Limiting values

In accordance with the Absolute Maximum Rating System (IEC 60134).

Symbol	Parameter	Conditions	Min	Max	Unit	
V _{DD}	supply voltage	[1]	-0.3	+4.6	V	
V _I	input voltage	[1]	-0.3	+5.5	V	
T _{stg}	storage temperature		-65	+150	°C	
V _{ESD}	electrostatic discharge voltage	HBM	[2]	-	2000	V
		CDM	[3]	-	1000	V

[1] All voltage values, except differential voltages, are with respect to network ground terminal.

[2] Human Body Model: ANSI/ESDA/JEDEC JDS-001-2012 (Revision of ANSI/ESDA/JEDEC JS-001-2011), ESDA/JEDEC Joint standard for ESD sensitivity testing, Human Body Model – Component level; Electrostatic Discharge Association, Rome, NY, USA; JEDEC Solid State Technology Association, Arlington, VA, USA.

[3] Charged Device Model: JESD22-C101E December 2009 (Revision of JESD22-C101D, October 2008), standard for ESD sensitivity testing, Charged Device Model – Component level; JEDEC Solid State Technology Association, Arlington, VA, USA.

8. Recommended operating conditions

Table 9. Operating conditions

Symbol	Parameter	Conditions	Min	Typ	Max	Unit
V _{DD}	supply voltage	3.3 V supply option	3.0	3.3	3.6	V
		initial supply voltage before power supply negotiation done [1]	2.3	-	-	V
V _I	input voltage	CMOS inputs	-0.3	-	+5.5	V
		MUX I/O pins	-0.3	-	V _{DD} + 0.3	V
T _{amb}	ambient temperature	operating in free air	-20	-	+85	°C

[1] During power supply negotiation only a limited supply voltage is available. The control logic and multiplexers must be in full function with degraded performance. The channel between LSTX/LSRX and DPMLO+/- must work. The initial R_{on} of DP MUX in [Table 14](#) should be < 50 Ω.

9. Characteristics

9.1 Device general characteristics

Table 10. General characteristics

Symbol	Parameter	Conditions	Min	Typ	Max	Unit
I_{DD}	supply current ^[1]	TB mode; $V_{DD} = 3.6$ V	-	0.25	0.35	mA
P_{cons}	power consumption ^[1]	TB mode; $V_{DD} = 3.6$ V; AUXIO_EN = 1, TB_ENA = 1 and DP_PD = 1	-	0.825	1.26	mW
		DP or DP++ modes; AUXIO_EN = 1, TB_ENA = 0 and DP_PD = 0	-	0.66	1.00	mW
		Sleep or DP Standby modes; (AUXIO_EN = 1, TB_ENA = 1 and CA_DET = DP_PD = 0) for Sleep mode or (AUXIO_EN = 0 and DP_PD = 0) for DP Standby mode	-	1	18	μ W
		Detect mode; AUXIO_EN = 1, TB_ENA = 0 and DP_PD = 1	-	1	18	μ W
		Standby mode; AUXIO_EN = 0, TB_ENA = X and DP_PD = 1	-	1	18	μ W
$t_{startup}$	start-up time	supply voltage valid to channel specified operating characteristics	-	100	500	μ s
t_{rcfg}	reconfiguration time	DP_PD, AUXIO_EN, TB_ENA or CA_DET state change to channel specified operating characteristics ^[2]	-	50	100	μ s

[1] Do not include current through R4.

[2] Outputs are undefined during reconfiguration, including enable and disable time of the multiplexers.

9.2 3 : 1 TB MUX channel characteristics

Table 11. TB channel of 2 : 1 10G MUX dynamic and static characteristics

Symbol	Parameter	Conditions	Min	Typ	Max	Unit
DDIL	differential insertion loss	channel is OFF				
		f = 5 GHz	-	-20	-	dB
		f = 100 MHz	-	-55	-	dB
		channel is ON				
		f = 5 GHz	-	-1.3	-	dB
		f = 100 MHz	-	-1	-	dB
DDRL	differential return loss	f = 5 GHz	-	-20	-	dB
		f = 100 MHz	-	-22	-	dB
DDNEXT	differential near-end crosstalk	adjacent channels are ON				
		f = 5 GHz	-	-18	-	dB
		f = 2.7 GHz	-	-25	-	dB
		f = 100 MHz	-	-60	-	dB
		f = 1 MHz	-	-70	-	dB
R_{on}	ON-state resistance	$V_{DD} = 3.3$ V; $V_I = 3.3$ V; $I_I = 5$ mA	-	8.5	12	Ω

Table 11. TB channel of 2 : 1 10G MUX dynamic and static characteristics ...continued

Symbol	Parameter	Conditions	Min	Typ	Max	Unit
B _{-3dB}	-3 dB bandwidth	differential	-	10	-	GHz
t _{PD}	propagation delay	between AUXIO and TB	-	70	-	ps
t _{sk(dif)}	differential skew time	intra-pair	-	5	-	ps
V _I	input voltage	TB+/TB- and AUXIO+/AUXIO-	0	-	V _{DD} + 0.3	V
V _{ID}	differential input voltage	TB+/TB- and AUXIO+/AUXIO-	-	-	1.2	V

Table 12. AUX - AUXIO channel of AUX MUX dynamic and static characteristics

Symbol	Parameter	Conditions	Min	Typ	Max	Unit		
DDIL	differential insertion loss	channel is OFF						
		f = 5 MHz	-	-80	-	dB		
		f = 360 MHz	-	-60	-	dB		
		channel is ON						
		f = 5 MHz	-	-1.1	-	dB		
		f = 360 MHz	-	-1.2	-	dB		
DDRL	differential return loss	f = 5 MHz	-	-19	-	dB		
		f = 360 MHz	-	-18	-	dB		
DDNEXT	differential near-end crosstalk	adjacent channels are ON						
		f = 5 GHz	-	-18	-	dB		
		f = 2.7 GHz	-	-25	-	dB		
		f = 100 MHz	-	-60	-	dB		
R _{on}	ON-state resistance	V _{DD} = 3.3 V; I _I = 10 mA; V _{IC} = 0.9V _{DD} for AUXIO-; V _{IC} = 0.1V _{DD} for AUXIO+	-	13	16	Ω		
		B _{-3dB}	-3 dB bandwidth	differential	-	3	-	GHz
		t _{PD}	propagation delay	between AUX and AUXIO	-	70	-	ps
		t _{sk(dif)}	differential skew time	intra-pair	-	5	-	ps
V _I	input voltage	AUX+/AUX- and AUXIO+/AUXIO-	0	-	V _{DD}	V		
V _{IC}	common-mode input voltage	AUX+/AUX- and AUXIO+/AUXIO-	0	-	V _{DD}	V		
V _{ID}	differential input voltage	AUX+/AUX- and AUXIO+/AUXIO-	-	-	1.4	V		
I _{LIH}	HIGH-level input leakage current	AUX+/AUX- pins; V _{DD} = max; V _I = V _{DD}	-	-	±1	μA		
I _{LIL}	LOW-level input leakage current	AUX+/AUX- pins; V _{DD} = max; V _I = GND	-	-	±1	μA		

Table 13. DDC - AUXIO channel of AUX MUX dynamic and static characteristics

Symbol	Parameter	Conditions	Min	Typ	Max	Unit
R _{on}	ON-state resistance	V _{DD} = 3.3 V; I _I = 10 mA	-	35	50	Ω
C _{in}	input capacitance	V _{DD} = 3.3 V; V _I = 3.3 V	-	0.2	-	pF
t _{PD}	propagation delay	between DDC and AUXIO	-	70	-	ps
I _{LIH}	HIGH-level input leakage current	DDC_DAT and DDC_CLK pins; V _{DD} = max; V _I = V _{DD}	-	-	±1.5	μA
I _{LIL}	LOW-level input leakage current	DDC_DAT and DDC_CLK pins; V _{DD} = max; V _I = GND	-	-	±1.5	μA

9.3 DP MUX channel characteristics

Table 14. Channel dynamic and static characteristics

Symbol	Parameter	Conditions	Min	Typ	Max	Unit
DDIL	differential insertion loss	DP-DPMLO path; channel is OFF				
		f = 2.7 GHz	-	-20	-	dB
		f = 1.35 GHz	-	-35	-	dB
		f = 100 MHz	-	-50	-	dB
		DP-DPMLO path; channel is ON				
		f = 2.7 GHz	-	-1.2	-	dB
		f = 1.35 GHz	-	-1.1	-	dB
		f = 100 MHz	-	-0.8	-	dB
α _{il(se)}	single-ended insertion loss	LS-DPMLO path; channel is OFF; f = 5 MHz	-	-60	-	dB
		LS-DPMLO path; channel is ON; f = 5 MHz	-	-1	-	dB
DDRL	differential return loss	DP-DPMLO path				
		f = 2.7 GHz	-	-15	-	dB
		f = 100 MHz	-	-20	-	dB
α _{rl(se)}	single-ended return loss	LS-DPMLO path; f = 5 MHz	-	-18	-	dB
DDNEXT	differential near-end crosstalk	adjacent channels are ON				
		f = 5 GHz	-	-18	-	dB
		f = 2.7 GHz	-	-25	-	dB
		f = 100 MHz	-	-60	-	dB
		f = 1 MHz	-	-70	-	dB
R _{on}	ON-state resistance	DP-DPMLO path; V _{DD} = 3.3 V; I _I = 5 mA	-	9	12	Ω
		LS-DPMLO path; V _{DD} = 3.3 V; I _I = 5 mA	-	16	22	Ω
		initial ON-state resistance before power supply negotiation done; V _{DD} = 2.3 V; I _I = 5 mA	-	35	50	Ω
B _{-3dB}	-3 dB bandwidth	differential; DP-DPMLO path	-	5.5	-	GHz
		single-ended; LS-DPMLO path	-	1	-	GHz
t _{PD}	propagation delay	between DP+/DP- and DPMLO+/DPMLO-	-	100	-	ps
t _{sk(dif)}	differential skew time	intra-pair	-	5	-	ps

Table 14. Channel dynamic and static characteristics ...continued

Symbol	Parameter	Conditions	Min	Typ	Max	Unit
V _I	input voltage	LSTX/LSRX to DPMLO+/DPMLO- channel	-0.3	-	V _{DD} + 0.3	V
V _{IC}	common-mode input voltage	DP+/DP- and DPMLO+/DPMLO-	0	-	V _{DD}	V
V _{ID}	differential input voltage	DP+/DP- to DPMLO+/DPMLO- channel	-	-	1.4	V
I _{LIH}	HIGH-level input leakage current	DP+/DP- and DPMLO+ pins; V _{DD} = max; V _I = V _{DD}	-	-	±1	μA
		DPMLO- pins; V _{DD} = max; V _I = V _{DD}	-	-	±5	μA
I _{LIL}	LOW-level input leakage current	DP+/DP- and DPMLO+/DPMLO- pins; V _{DD} = max; V _I = GND	-	-	±1	μA

9.4 Control signals characteristics

Table 15. CA_DET input buffer characteristics

Symbol	Parameter	Conditions	Min	Typ	Max	Unit
V _{IH}	HIGH-level input voltage		2	-	-	V
V _{IL}	LOW-level input voltage		-	-	0.8	V
I _{LI}	input leakage current	measured with input at V _{IH} = V _{DD} and V _{IL} = 0 V [1]	-	-	0.1	μA

[1] The leakage current on CA_DET pin must not drive the 1 MΩ pull-down to a HIGH level.

Table 16. HPD input buffer characteristics

Symbol	Parameter	Conditions	Min	Typ	Max	Unit
V _{IH}	HIGH-level input voltage		2	-	5	V
V _{IL}	LOW-level input voltage		-	-	0.8	V

Table 17. TB_ENA, DP_PD or AUXIO_EN input characteristics

Symbol	Parameter	Conditions	Min	Typ	Max	Unit
V _{IH}	HIGH-level input voltage	CMOS inputs	0.7 × V _{DD}	-	-	V
V _{IL}	LOW-level input voltage	CMOS inputs	-	-	0.3 × V _{DD}	V
I _{LI}	input leakage current	measured with input at V _{IH} = V _{DD} and V _{IL} = 0 V	-	1	10	μA

Table 18. CA_DETOUT and HPDOUT output buffer characteristics

Symbol	Parameter	Conditions	Min	Typ	Max	Unit
V _{OL}	LOW-level output voltage	I _{OL} = 2 mA; V _{DD} = 3 V	0	-	0.4	V
V _{OH}	HIGH-level output voltage	pull-up voltage; I _{OH} = -2 mA; V _{DD} = 3 V	2.5	-	-	V
t _{PD}	propagation delay	load capacitance C _L = 5 pF	-	50	100	ns

9.5 Integrated LSRX buffer characteristics

Table 19. LSRX buffer characteristics

Symbol	Parameter	Conditions	Min	Typ	Max	Unit
V _{th(LH)}	positive-going threshold voltage	input; V _{DD} = 3.3 V ± 10 %	0.9	1.1	1.24	V
		input; V _{DD} = 2.3 V	0.8	0.9	1.02	V
V _{th(HL)}	negative-going threshold voltage	input; V _{DD} = 3.3 V ± 10 %	0.58	0.7	0.84	V
		input; V _{DD} = 2.3 V	0.5	0.57	0.63	V
V _{OL}	LOW-level output voltage	I _{OL} = 2 mA; V _{DD} = 3 V	-	0.2	0.4	V
		I _{OL} = 0.5 mA; V _{DD} = 2.3 V	-	0.1	0.2	V
V _{OH}	HIGH-level output voltage	pull-up voltage; I _{OH} = -2 mA; V _{DD} = 3 V	2.5	-	-	V
		pull-up voltage; I _{OH} = -0.5 mA; V _{DD} = 2.3 V	2.1	-	-	V
t _{PD}	propagation delay	load capacitance C _L = 8 pF	-	2	10	ns

9.6 Bias resistor characteristics

Table 20. Characteristics of AUXIO+ pin in DP/DP++ mode

Symbol	Parameter	Conditions	Min	Typ	Max	Unit
R _{pd}	pull-down resistance	resistor R2; AUXIO_EN = 1, TB_ENA = DP_PD = 0	68	85	102	kΩ

Table 21. Characteristics of AUXIO- pin in DP/DP++ mode

Symbol	Parameter	Conditions	Min	Typ	Max	Unit
R _{PU}	pull-up resistance	resistor R3; AUXIO_EN = 1, TB_ENA = DP_PD = 0	68	85	102	kΩ

Table 22. Characteristics of DPML0- pin in TB mode

Symbol	Parameter	Conditions	Min	Typ	Max	Unit
R _{pd}	pull-down resistance	resistor R1; AUXIO_EN = TB_ENA = DP_PD = 1	0.8	1	1.2	MΩ

Table 23. Characteristics of LSTX pin

Symbol	Parameter	Conditions	Min	Typ	Max	Unit
R _{PU}	pull-up resistance	resistor R4	7	8.75	10.5	kΩ

10. Package outline

HVQFN24: plastic thermal enhanced very thin quad flat package; no leads; 24 terminals; body 3 x 3 x 0.85 mm

SOT905-1

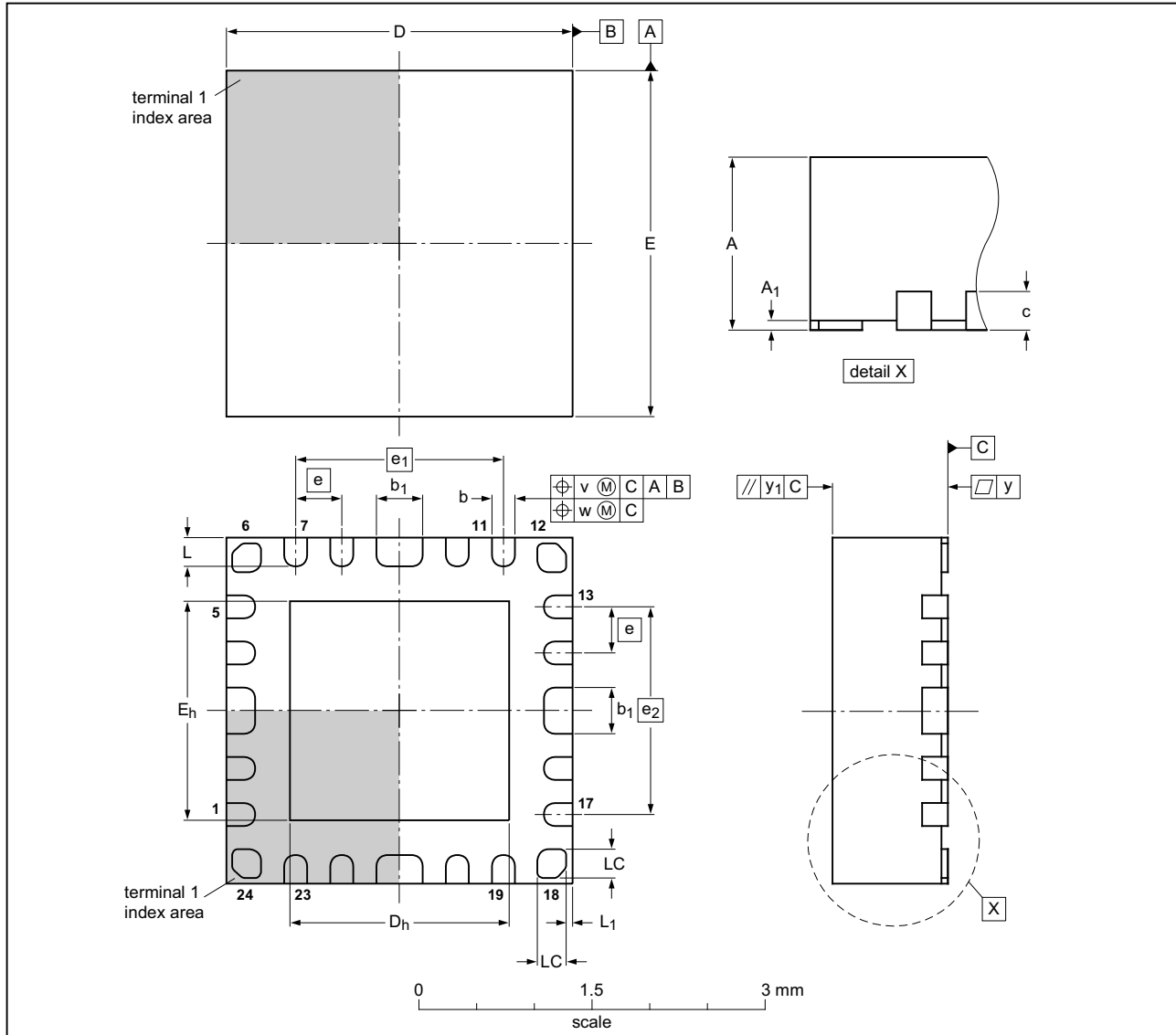

DIMENSIONS (mm are the original dimensions)

UNIT	A ⁽¹⁾ max	A ₁	b	b ₁	c	D ⁽¹⁾	D _h	E ⁽¹⁾	E _h	e	e ₁	e ₂	L	L ₁	LC	v	w	y	y ₁
mm	1	0.05 0.00	0.25 0.15	0.45 0.35	0.2	3.1 2.9	2.05 1.75	3.1 2.9	2.05 1.75	0.4	1.8	1.8	0.35 0.15	0.1 0.0	0.3 0.2	0.1	0.05	0.05	0.1

Note

1. Plastic or metal protrusions of 0.075 mm maximum per side are not included

OUTLINE VERSION	REFERENCES			EUROPEAN PROJECTION	ISSUE DATE
	IEC	JEDEC	JEITA		
SOT905-1	---	---	---		06-03-13- 06-03-31

Fig 3. Package outline SOT905-1 (HVQFN24)

11. Soldering of SMD packages

This text provides a very brief insight into a complex technology. A more in-depth account of soldering ICs can be found in Application Note *AN10365 "Surface mount reflow soldering description"*.

11.1 Introduction to soldering

Soldering is one of the most common methods through which packages are attached to Printed Circuit Boards (PCBs), to form electrical circuits. The soldered joint provides both the mechanical and the electrical connection. There is no single soldering method that is ideal for all IC packages. Wave soldering is often preferred when through-hole and Surface Mount Devices (SMDs) are mixed on one printed wiring board; however, it is not suitable for fine pitch SMDs. Reflow soldering is ideal for the small pitches and high densities that come with increased miniaturization.

11.2 Wave and reflow soldering

Wave soldering is a joining technology in which the joints are made by solder coming from a standing wave of liquid solder. The wave soldering process is suitable for the following:

- Through-hole components
- Leaded or leadless SMDs, which are glued to the surface of the printed circuit board

Not all SMDs can be wave soldered. Packages with solder balls, and some leadless packages which have solder lands underneath the body, cannot be wave soldered. Also, leaded SMDs with leads having a pitch smaller than ~0.6 mm cannot be wave soldered, due to an increased probability of bridging.

The reflow soldering process involves applying solder paste to a board, followed by component placement and exposure to a temperature profile. Leaded packages, packages with solder balls, and leadless packages are all reflow solderable.

Key characteristics in both wave and reflow soldering are:

- Board specifications, including the board finish, solder masks and vias
- Package footprints, including solder thieves and orientation
- The moisture sensitivity level of the packages
- Package placement
- Inspection and repair
- Lead-free soldering versus SnPb soldering

11.3 Wave soldering

Key characteristics in wave soldering are:

- Process issues, such as application of adhesive and flux, clinching of leads, board transport, the solder wave parameters, and the time during which components are exposed to the wave
- Solder bath specifications, including temperature and impurities

11.4 Reflow soldering

Key characteristics in reflow soldering are:

- Lead-free versus SnPb soldering; note that a lead-free reflow process usually leads to higher minimum peak temperatures (see [Figure 4](#)) than a SnPb process, thus reducing the process window
- Solder paste printing issues including smearing, release, and adjusting the process window for a mix of large and small components on one board
- Reflow temperature profile; this profile includes preheat, reflow (in which the board is heated to the peak temperature) and cooling down. It is imperative that the peak temperature is high enough for the solder to make reliable solder joints (a solder paste characteristic). In addition, the peak temperature must be low enough that the packages and/or boards are not damaged. The peak temperature of the package depends on package thickness and volume and is classified in accordance with [Table 24](#) and [25](#)

Table 24. SnPb eutectic process (from J-STD-020D)

Package thickness (mm)	Package reflow temperature (°C)	
	Volume (mm ³)	
	< 350	≥ 350
< 2.5	235	220
≥ 2.5	220	220

Table 25. Lead-free process (from J-STD-020D)

Package thickness (mm)	Package reflow temperature (°C)		
	Volume (mm ³)		
	< 350	350 to 2000	> 2000
< 1.6	260	260	260
1.6 to 2.5	260	250	245
> 2.5	250	245	245

Moisture sensitivity precautions, as indicated on the packing, must be respected at all times.

Studies have shown that small packages reach higher temperatures during reflow soldering, see [Figure 4](#).

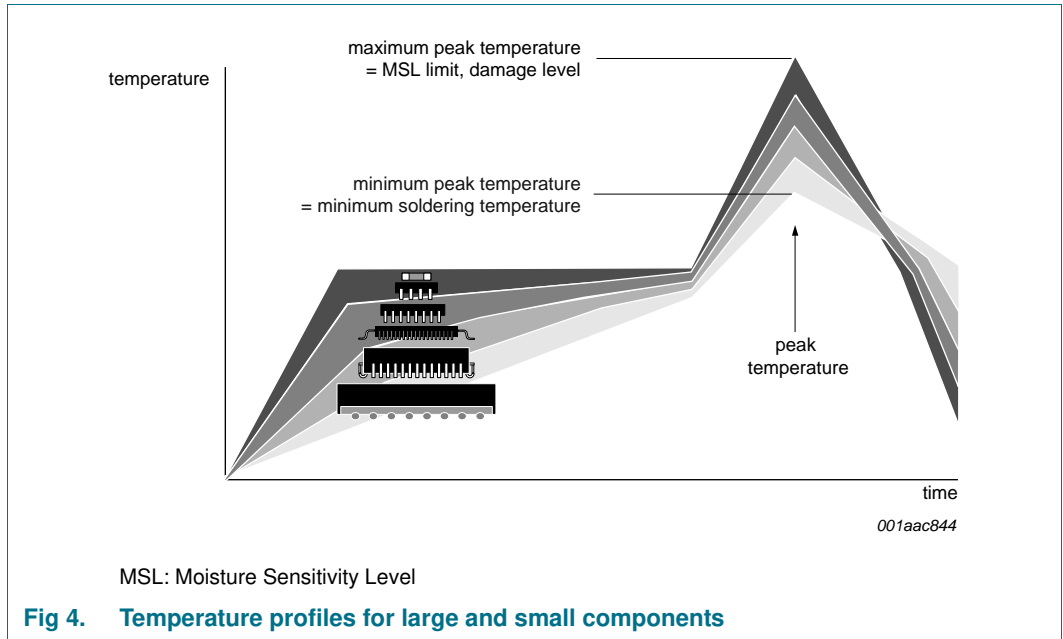

For further information on temperature profiles, refer to Application Note AN10365 “Surface mount reflow soldering description”.

12. Abbreviations

Table 26. Abbreviations

Acronym	Description
CDM	Charged-Device Model
CMOS	Complementary Metal-Oxide Semiconductor
DP	DisplayPort
ESD	ElectroStatic Discharge
HBM	Human Body Model
HPD	Hot Plug Detect
I/O	Input/Output
MUX	multiplexer
PCB	Printed-Circuit Board

13. Revision history

Table 27. Revision history

Document ID	Release date	Data sheet status	Change notice	Supersedes
CBTL05024 v.4	20140327	Product data sheet	-	CBTL05024 v.3
Modifications:	<ul style="list-style-type: none">The security status of this data sheet has been altered from company confidential to company public.			
CBTL05024 v.3	20131014	Product data sheet	-	CBTL05024 v.2
CBTL05024 v.2	20130715	Product data sheet	-	CBTL05024 v.1
CBTL05024 v.1	20121116	Product data sheet	-	-

14. Legal information

14.1 Data sheet status

Document status ^{[1][2]}	Product status ^[3]	Definition
Objective [short] data sheet	Development	This document contains data from the objective specification for product development.
Preliminary [short] data sheet	Qualification	This document contains data from the preliminary specification.
Product [short] data sheet	Production	This document contains the product specification.

[1] Please consult the most recently issued document before initiating or completing a design.

[2] The term 'short data sheet' is explained in section "Definitions".

[3] The product status of device(s) described in this document may have changed since this document was published and may differ in case of multiple devices. The latest product status information is available on the Internet at URL <http://www.nxp.com>.

14.2 Definitions

Draft — The document is a draft version only. The content is still under internal review and subject to formal approval, which may result in modifications or additions. NXP Semiconductors does not give any representations or warranties as to the accuracy or completeness of information included herein and shall have no liability for the consequences of use of such information.

Short data sheet — A short data sheet is an extract from a full data sheet with the same product type number(s) and title. A short data sheet is intended for quick reference only and should not be relied upon to contain detailed and full information. For detailed and full information see the relevant full data sheet, which is available on request via the local NXP Semiconductors sales office. In case of any inconsistency or conflict with the short data sheet, the full data sheet shall prevail.

Product specification — The information and data provided in a Product data sheet shall define the specification of the product as agreed between NXP Semiconductors and its customer, unless NXP Semiconductors and customer have explicitly agreed otherwise in writing. In no event however, shall an agreement be valid in which the NXP Semiconductors product is deemed to offer functions and qualities beyond those described in the Product data sheet.

14.3 Disclaimers

Limited warranty and liability — Information in this document is believed to be accurate and reliable. However, NXP Semiconductors does not give any representations or warranties, expressed or implied, as to the accuracy or completeness of such information and shall have no liability for the consequences of use of such information. NXP Semiconductors takes no responsibility for the content in this document if provided by an information source outside of NXP Semiconductors.

In no event shall NXP Semiconductors be liable for any indirect, incidental, punitive, special or consequential damages (including - without limitation - lost profits, lost savings, business interruption, costs related to the removal or replacement of any products or rework charges) whether or not such damages are based on tort (including negligence), warranty, breach of contract or any other legal theory.

Notwithstanding any damages that customer might incur for any reason whatsoever, NXP Semiconductors' aggregate and cumulative liability towards customer for the products described herein shall be limited in accordance with the *Terms and conditions of commercial sale* of NXP Semiconductors.

Right to make changes — NXP Semiconductors reserves the right to make changes to information published in this document, including without limitation specifications and product descriptions, at any time and without notice. This document supersedes and replaces all information supplied prior to the publication hereof.

Suitability for use — NXP Semiconductors products are not designed, authorized or warranted to be suitable for use in life support, life-critical or safety-critical systems or equipment, nor in applications where failure or malfunction of an NXP Semiconductors product can reasonably be expected to result in personal injury, death or severe property or environmental damage. NXP Semiconductors and its suppliers accept no liability for inclusion and/or use of NXP Semiconductors products in such equipment or applications and therefore such inclusion and/or use is at the customer's own risk.

Applications — Applications that are described herein for any of these products are for illustrative purposes only. NXP Semiconductors makes no representation or warranty that such applications will be suitable for the specified use without further testing or modification.

Customers are responsible for the design and operation of their applications and products using NXP Semiconductors products, and NXP Semiconductors accepts no liability for any assistance with applications or customer product design. It is customer's sole responsibility to determine whether the NXP Semiconductors product is suitable and fit for the customer's applications and products planned, as well as for the planned application and use of customer's third party customer(s). Customers should provide appropriate design and operating safeguards to minimize the risks associated with their applications and products.

NXP Semiconductors does not accept any liability related to any default, damage, costs or problem which is based on any weakness or default in the customer's applications or products, or the application or use by customer's third party customer(s). Customer is responsible for doing all necessary testing for the customer's applications and products using NXP Semiconductors products in order to avoid a default of the applications and the products or of the application or use by customer's third party customer(s). NXP does not accept any liability in this respect.

Limiting values — Stress above one or more limiting values (as defined in the Absolute Maximum Ratings System of IEC 60134) will cause permanent damage to the device. Limiting values are stress ratings only and (proper) operation of the device at these or any other conditions above those given in the Recommended operating conditions section (if present) or the Characteristics sections of this document is not warranted. Constant or repeated exposure to limiting values will permanently and irreversibly affect the quality and reliability of the device.

Terms and conditions of commercial sale — NXP Semiconductors products are sold subject to the general terms and conditions of commercial sale, as published at <http://www.nxp.com/profile/terms>, unless otherwise agreed in a valid written individual agreement. In case an individual agreement is concluded only the terms and conditions of the respective agreement shall apply. NXP Semiconductors hereby expressly objects to applying the customer's general terms and conditions with regard to the purchase of NXP Semiconductors products by customer.

No offer to sell or license — Nothing in this document may be interpreted or construed as an offer to sell products that is open for acceptance or the grant, conveyance or implication of any license under any copyrights, patents or other industrial or intellectual property rights.

Export control — This document as well as the item(s) described herein may be subject to export control regulations. Export might require a prior authorization from competent authorities.

Non-automotive qualified products — Unless this data sheet expressly states that this specific NXP Semiconductors product is automotive qualified, the product is not suitable for automotive use. It is neither qualified nor tested in accordance with automotive testing or application requirements. NXP Semiconductors accepts no liability for inclusion and/or use of non-automotive qualified products in automotive equipment or applications.

In the event that customer uses the product for design-in and use in automotive applications to automotive specifications and standards, customer (a) shall use the product without NXP Semiconductors' warranty of the product for such automotive applications, use and specifications, and (b) whenever customer uses the product for automotive applications beyond

NXP Semiconductors' specifications such use shall be solely at customer's own risk, and (c) customer fully indemnifies NXP Semiconductors for any liability, damages or failed product claims resulting from customer design and use of the product for automotive applications beyond NXP Semiconductors' standard warranty and NXP Semiconductors' product specifications.

Translations — A non-English (translated) version of a document is for reference only. The English version shall prevail in case of any discrepancy between the translated and English versions.

14.4 Trademarks

Notice: All referenced brands, product names, service names and trademarks are the property of their respective owners.

15. Contact information

For more information, please visit: <http://www.nxp.com>

For sales office addresses, please send an email to: salesaddresses@nxp.com

16. Contents

1	General description	1
2	Features and benefits	1
2.1	TB MUX 3 : 1 switch	1
2.2	DP MUX 2 : 1 switch	2
2.3	General	2
3	Ordering information	3
3.1	Ordering options	3
4	Block diagram	4
5	Pinning information	5
5.1	Pinning	5
5.2	Pin description	6
6	Functional description	7
6.1	Buffer function tables	7
6.2	AUX MUX function table	7
6.3	Operation modes of both DPML MUX and TB MUX	7
7	Limiting values	8
8	Recommended operating conditions	8
9	Characteristics	9
9.1	Device general characteristics	9
9.2	3 : 1 TB MUX channel characteristics	9
9.3	DP MUX channel characteristics	11
9.4	Control signals characteristics	12
9.5	Integrated LSRX buffer characteristics	13
9.6	Bias resistor characteristics	13
10	Package outline	14
11	Soldering of SMD packages	15
11.1	Introduction to soldering	15
11.2	Wave and reflow soldering	15
11.3	Wave soldering	15
11.4	Reflow soldering	16
12	Abbreviations	17
13	Revision history	18
14	Legal information	19
14.1	Data sheet status	19
14.2	Definitions	19
14.3	Disclaimers	19
14.4	Trademarks	20
15	Contact information	20
16	Contents	21

Please be aware that important notices concerning this document and the product(s) described herein, have been included in section 'Legal information'.

© NXP Semiconductors N.V. 2014.

All rights reserved.

For more information, please visit: <http://www.nxp.com>

For sales office addresses, please send an email to: salesaddresses@nxp.com

Date of release: 27 March 2014

Document identifier: CBTL05024