



STEVAl-ISV002V1

3000 W photovoltaic converter for grid-connected applications

Data brief

Features

- DC-DC input voltage: 200 V to 400 V
- DC-DC output voltage: 450 V
- DC-AC output voltage: 230 Vac
- Nominal output power: 3 kW
- DC-AC switching frequency: 17 KHz
- DC-DC switching frequency: 35 KHz
- Transformer turns ratio: 1.2
- Grid voltage: 230 V_{rms} +/-20%
- Grid frequency: 50 Hz
- Power factor: above 10%; rated power > 0.9
- THD @ full load: < 5%
- RoHS compliant

Description

In recent years, interest in photovoltaic (PV) applications has grown exponentially. Because PV systems require an electronic interface to be connected to the grid or standalone loads, the PV market has become appealing for many power electronics manufacturers.

The STEVAL-ISV002V1 demonstration board implements a conversion system for PV applications with the aim of achieving high efficiency and significant reduction in production costs. It consists of a high-frequency isolated input power section which performs the DC-DC conversion, and an inverter section capable of delivering sinusoidal current at 50 Hz to the grid.

The system operates with input voltages in the range of 200 V to 400 V, and is tied to the grid at 230 V_{rms}, 50 Hz, through an LCL filter.

Other unique characteristics of the proposed converter are integration level, decoupled active and reactive power control and flexibility towards the source.



A fully digital control algorithm, including power management for grid-connected operation and MPPT (maximum power point tracking) algorithm, has been implemented on a dedicated control board, equipped with a latest-generation 32-bit (STM32) microcontroller.

October 2010

Doc ID 17233 Rev 2

1/11

For further information contact your local STMicroelectronics sales office.

www.st.com

1 Schematic diagrams

Figure 1. STEVAL-ISV002V1 power stage circuit schematic

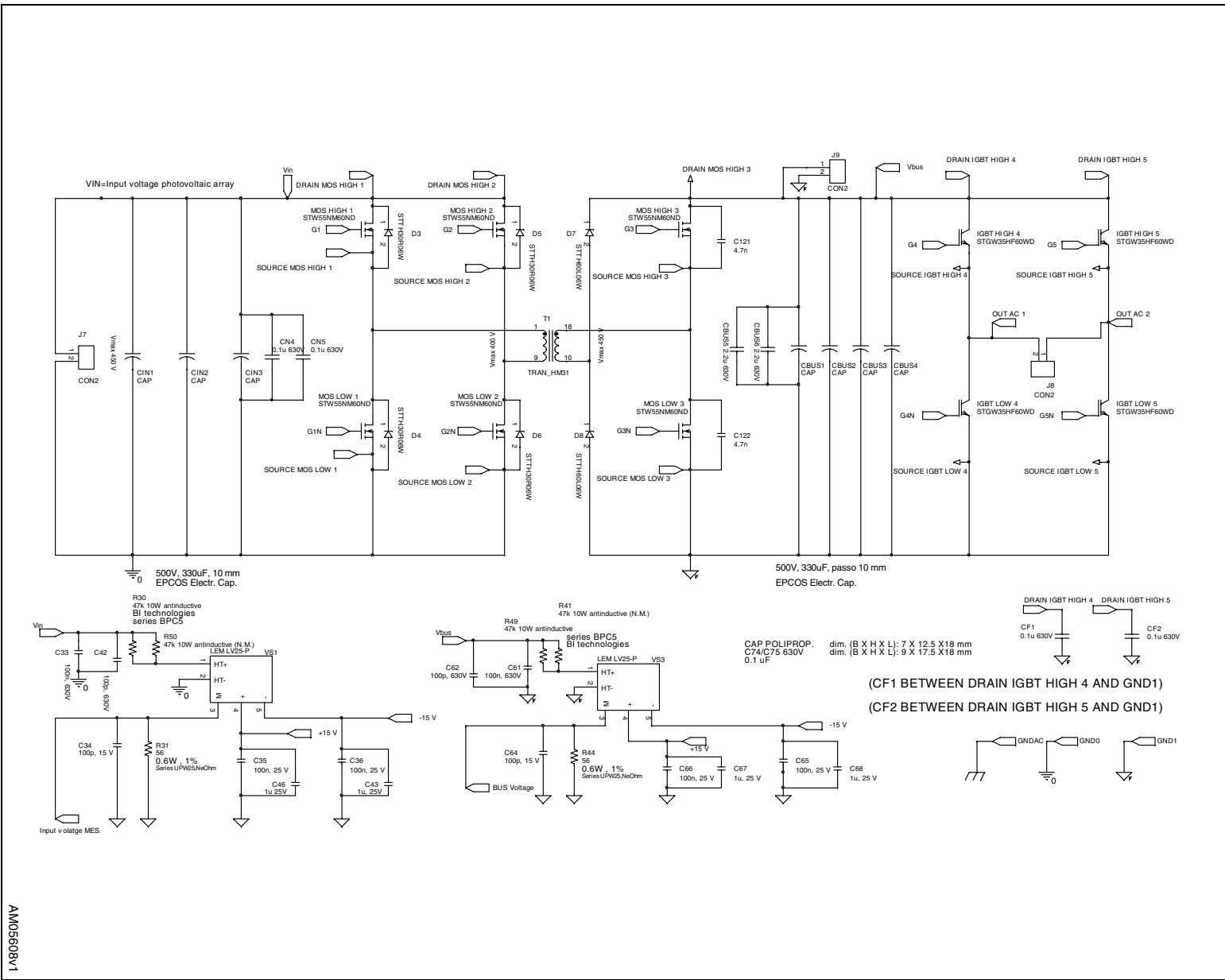

AM05608V1



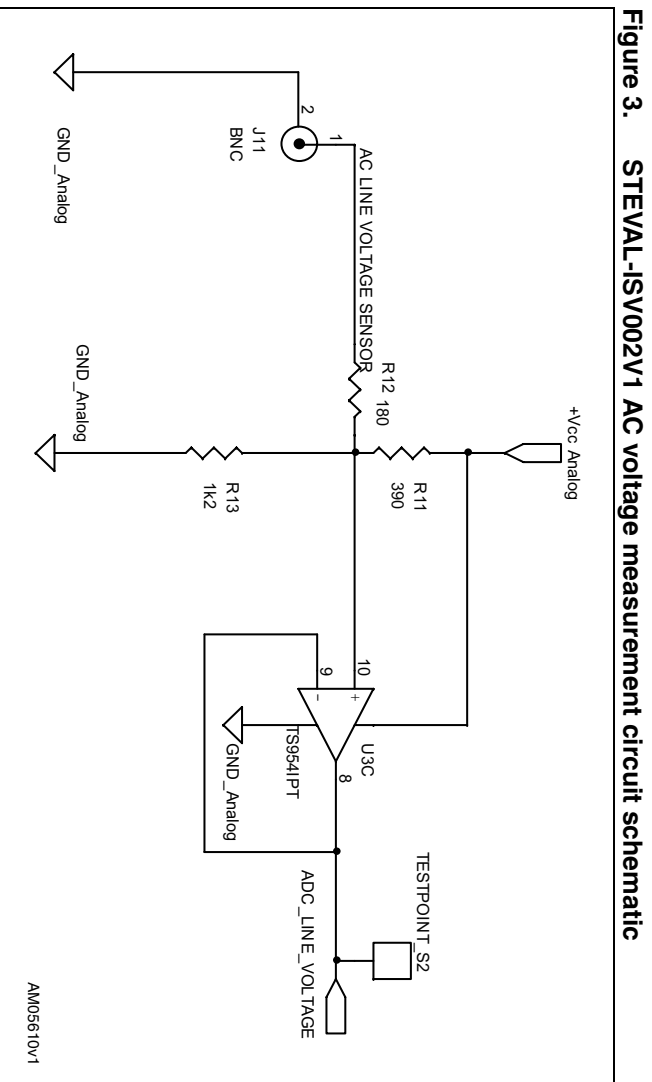

Figure 3. STEVAL-ISV002V1 AC voltage measurement circuit schematic

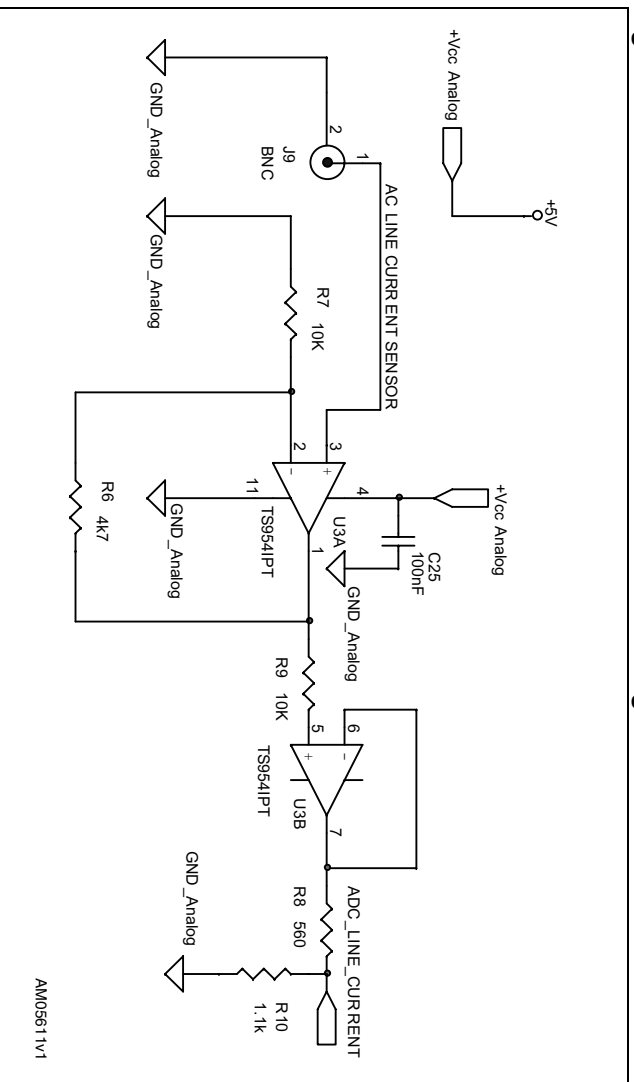
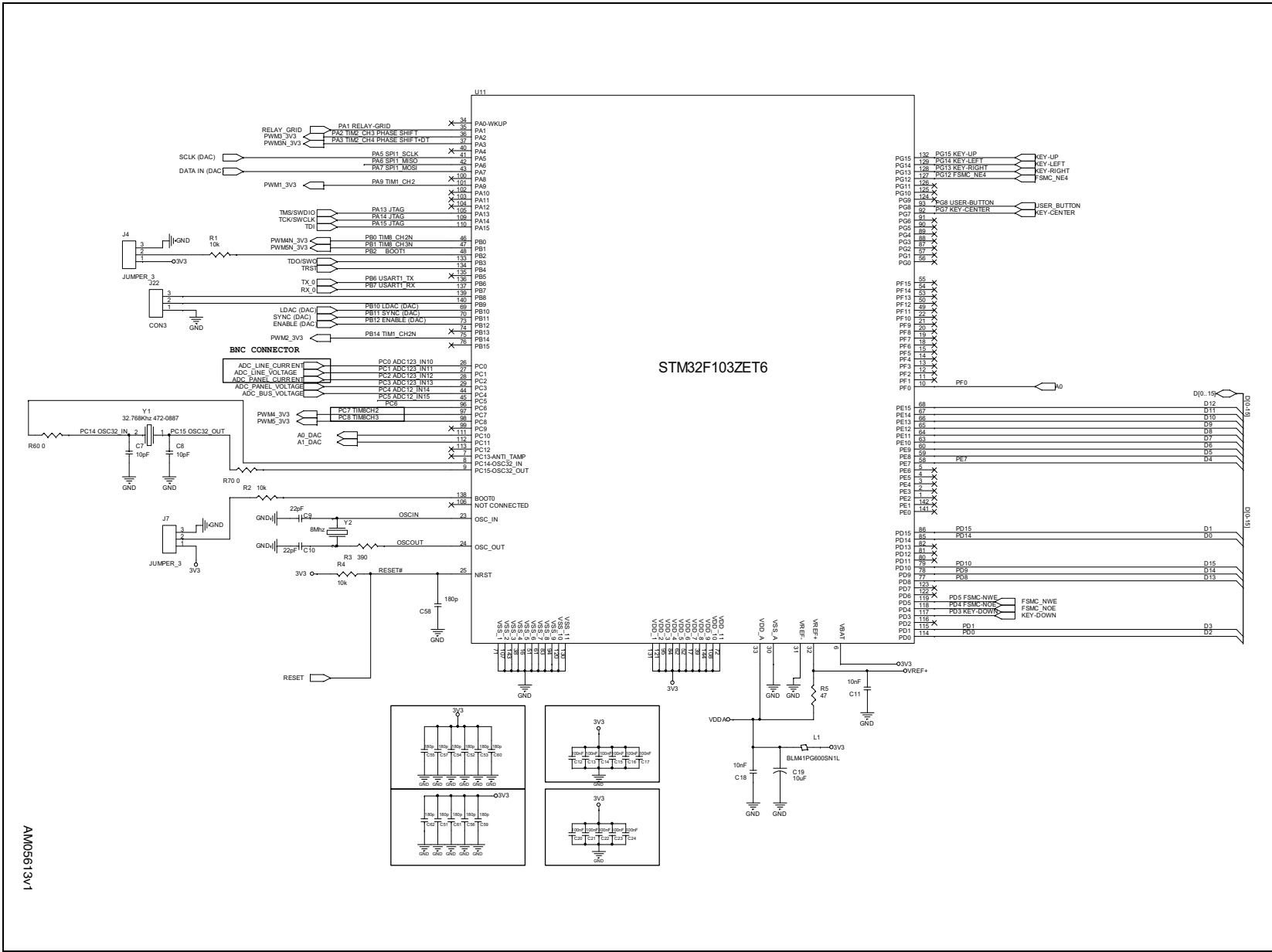

Figure 4. STEVAL-ISV002V1 line current conditioning circuit schematic



AM05613V1

Figure 5. STM32 microcontroller circuit schematic

Figure 6. DC-DC converter driver circuit schematic

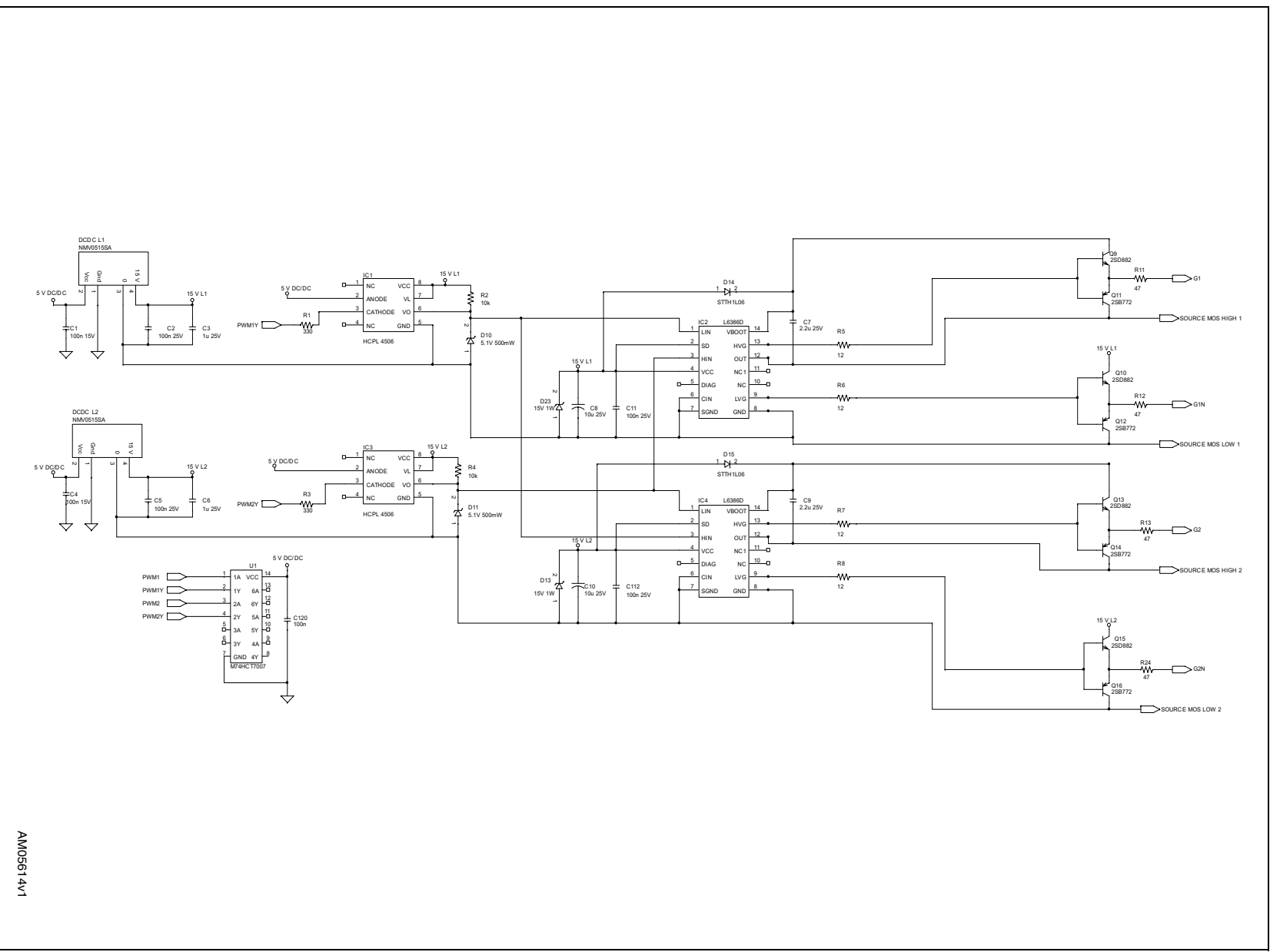

AM05614v1



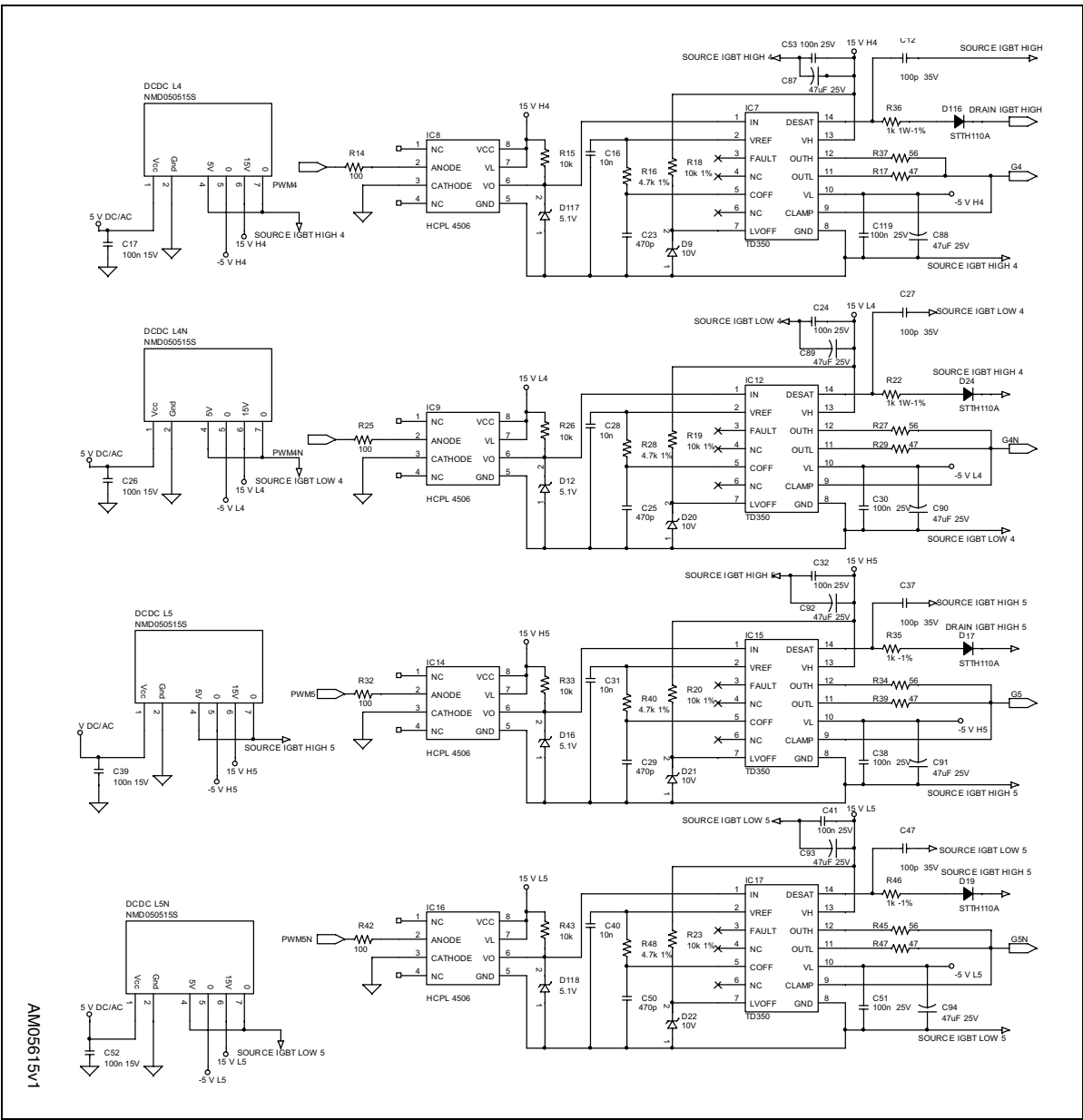
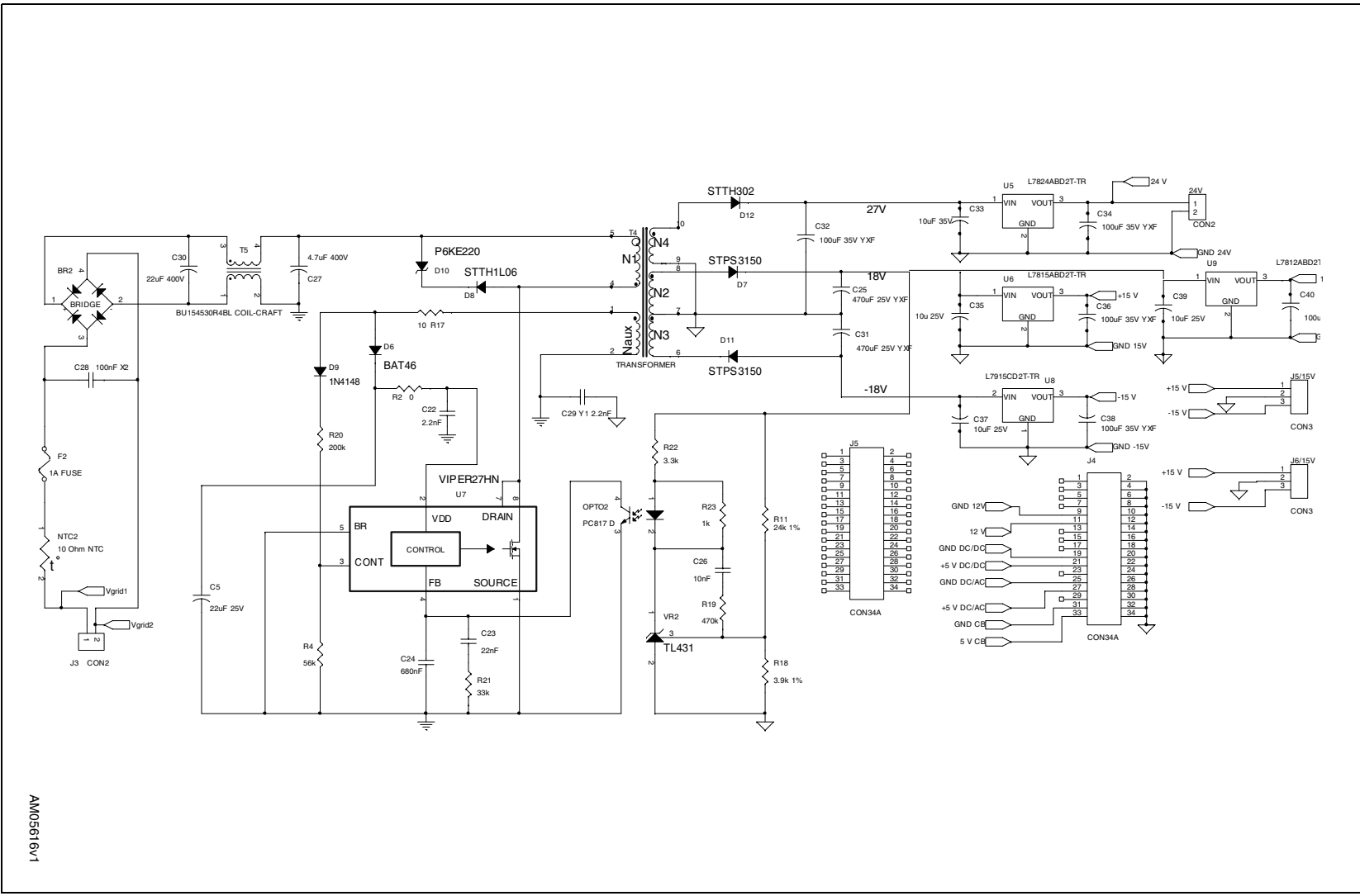

Figure 7. DC-AC converter driver circuit schematic

Figure 8. 5 V, 1 A flyback converter with VIPER17HN schematic



AM05616v1



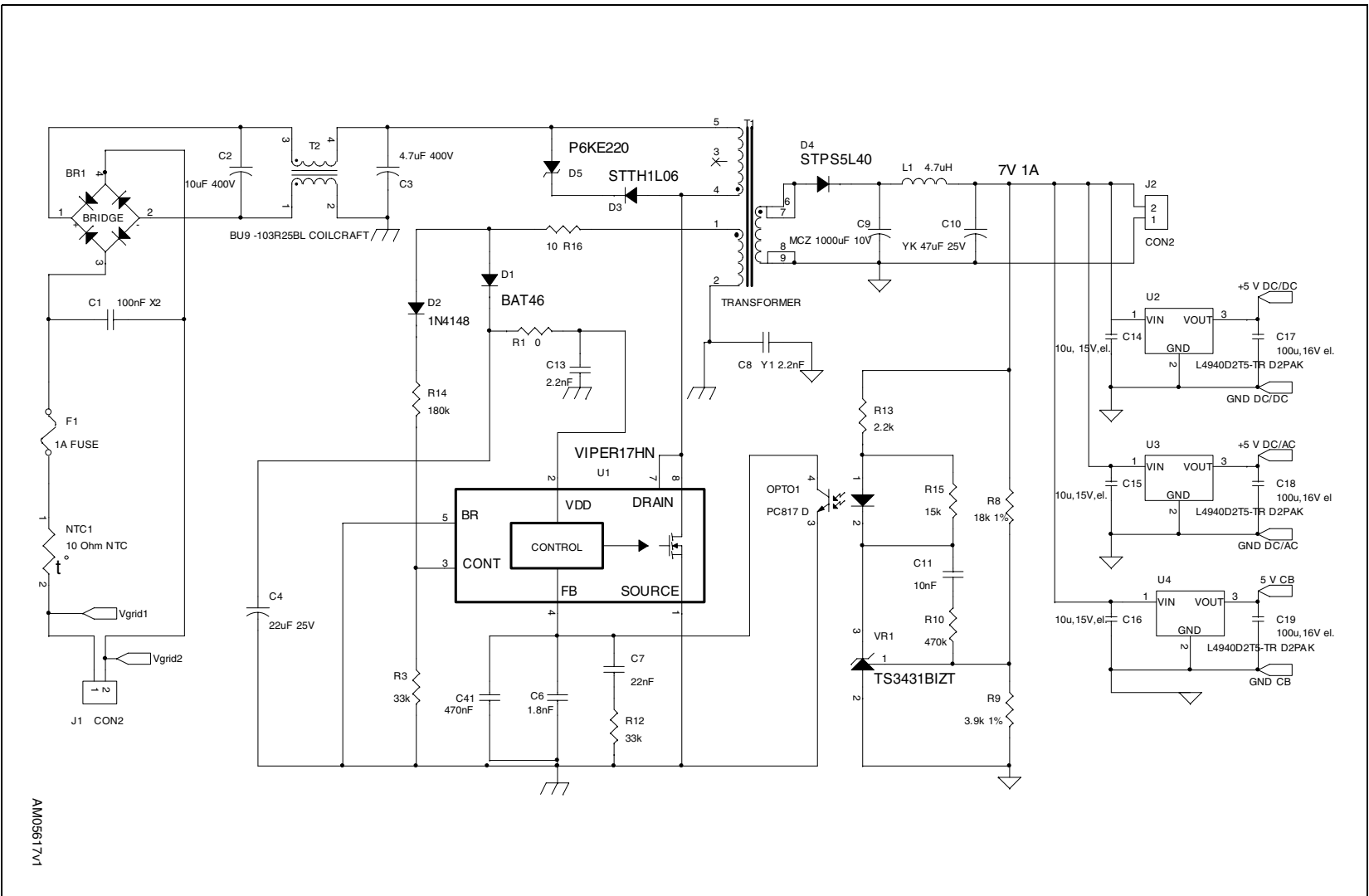

Figure 9. Multi-output flyback converter with VIPER27HN schematic

2 Revision history

Table 1. Document revision history

Date	Revision	Changes
05-Mar-2010	1	Initial release.
27-Oct-2010	2	<ul style="list-style-type: none">– Updated IGBT part numbers in <i>Figure 1: STEVAL-ISV002V1 power stage circuit schematic on page 2</i> from STGW35NC60WD to STGW35HF60WD.– Minor changes to placement and font sizes of component labels in all schematic diagrams to improve readability.

Please Read Carefully:

Information in this document is provided solely in connection with ST products. STMicroelectronics NV and its subsidiaries ("ST") reserve the right to make changes, corrections, modifications or improvements, to this document, and the products and services described herein at any time, without notice.

All ST products are sold pursuant to ST's terms and conditions of sale.

Purchasers are solely responsible for the choice, selection and use of the ST products and services described herein, and ST assumes no liability whatsoever relating to the choice, selection or use of the ST products and services described herein.

No license, express or implied, by estoppel or otherwise, to any intellectual property rights is granted under this document. If any part of this document refers to any third party products or services it shall not be deemed a license grant by ST for the use of such third party products or services, or any intellectual property contained therein or considered as a warranty covering the use in any manner whatsoever of such third party products or services or any intellectual property contained therein.

UNLESS OTHERWISE SET FORTH IN ST'S TERMS AND CONDITIONS OF SALE ST DISCLAIMS ANY EXPRESS OR IMPLIED WARRANTY WITH RESPECT TO THE USE AND/OR SALE OF ST PRODUCTS INCLUDING WITHOUT LIMITATION IMPLIED WARRANTIES OF MERCHANTABILITY, FITNESS FOR A PARTICULAR PURPOSE (AND THEIR EQUIVALENTS UNDER THE LAWS OF ANY JURISDICTION), OR INFRINGEMENT OF ANY PATENT, COPYRIGHT OR OTHER INTELLECTUAL PROPERTY RIGHT.

UNLESS EXPRESSLY APPROVED IN WRITING BY AN AUTHORIZED ST REPRESENTATIVE, ST PRODUCTS ARE NOT RECOMMENDED, AUTHORIZED OR WARRANTED FOR USE IN MILITARY, AIR CRAFT, SPACE, LIFE SAVING, OR LIFE SUSTAINING APPLICATIONS, NOR IN PRODUCTS OR SYSTEMS WHERE FAILURE OR MALFUNCTION MAY RESULT IN PERSONAL INJURY, DEATH, OR SEVERE PROPERTY OR ENVIRONMENTAL DAMAGE. ST PRODUCTS WHICH ARE NOT SPECIFIED AS "AUTOMOTIVE GRADE" MAY ONLY BE USED IN AUTOMOTIVE APPLICATIONS AT USER'S OWN RISK.

Resale of ST products with provisions different from the statements and/or technical features set forth in this document shall immediately void any warranty granted by ST for the ST product or service described herein and shall not create or extend in any manner whatsoever, any liability of ST.

ST and the ST logo are trademarks or registered trademarks of ST in various countries.

Information in this document supersedes and replaces all information previously supplied.

The ST logo is a registered trademark of STMicroelectronics. All other names are the property of their respective owners.

© 2010 STMicroelectronics - All rights reserved

STMicroelectronics group of companies

Australia - Belgium - Brazil - Canada - China - Czech Republic - Finland - France - Germany - Hong Kong - India - Israel - Italy - Japan - Malaysia - Malta - Morocco - Philippines - Singapore - Spain - Sweden - Switzerland - United Kingdom - United States of America

www.st.com

