

THIS DRAWING IS UNPUBLISHED. RELEASED FOR PUBLICATION
 © COPYRIGHT - By - ALL RIGHTS RESERVED.

LOC	DIST	REVISIONS			
P	LTR	DESCRIPTION	DATE	DWN	APVD
AF	50	K	REVISED PER ECR-19-000318	21JAN2019	BDA DH

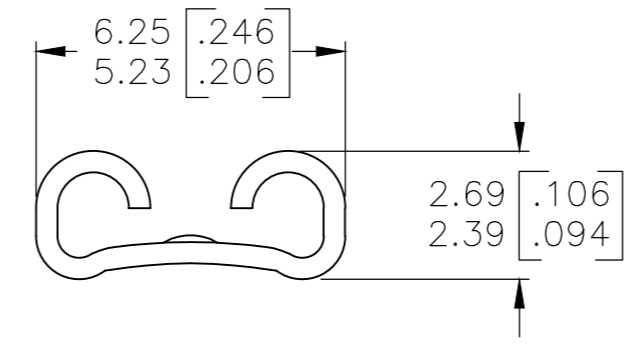
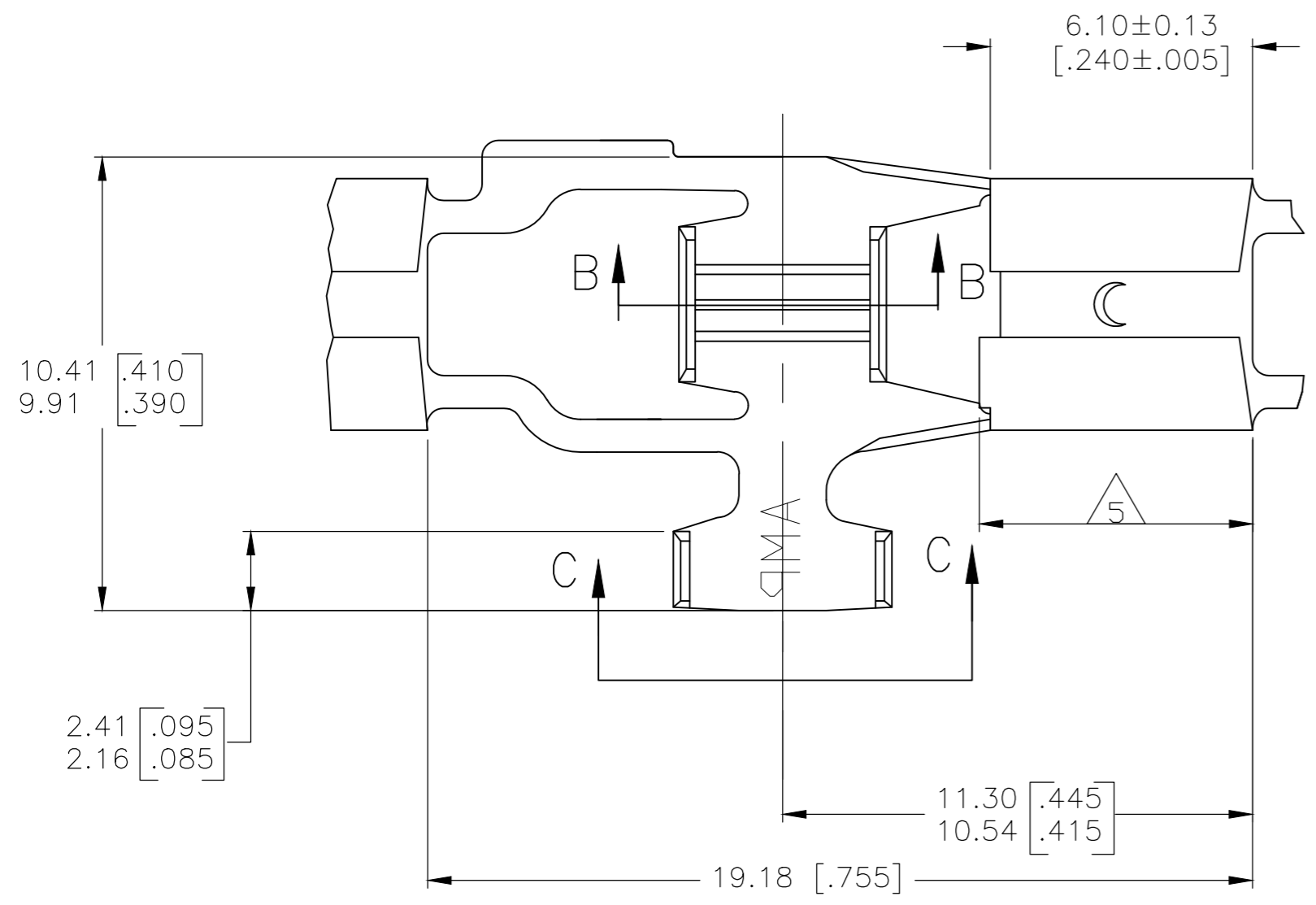

VIEW A-A

- CONTINUOUS STRIP ON REELS.
 - MATING TAB THK TO BE 0.508±0.025 [.020±.001]
 - WIRE SIZE IS #18-#14 AWG.
 - INSULATION RANGE IS 1.52-3.81 [.060-.150] DIA.
- △ RECEPTACLE LENGTH CAN BE GREATER BY UP TO 0.25 [.010] MAX FROM THE OPPOSITE SIDE.

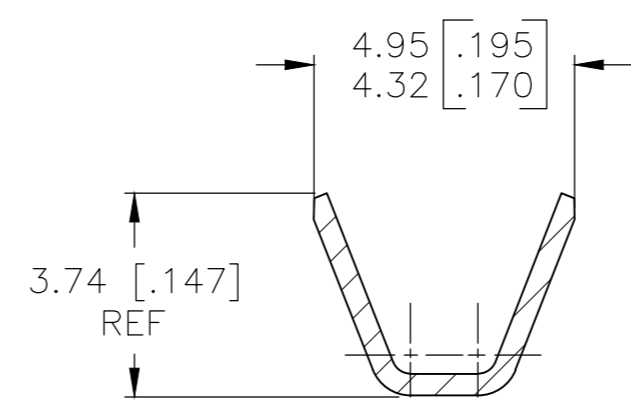
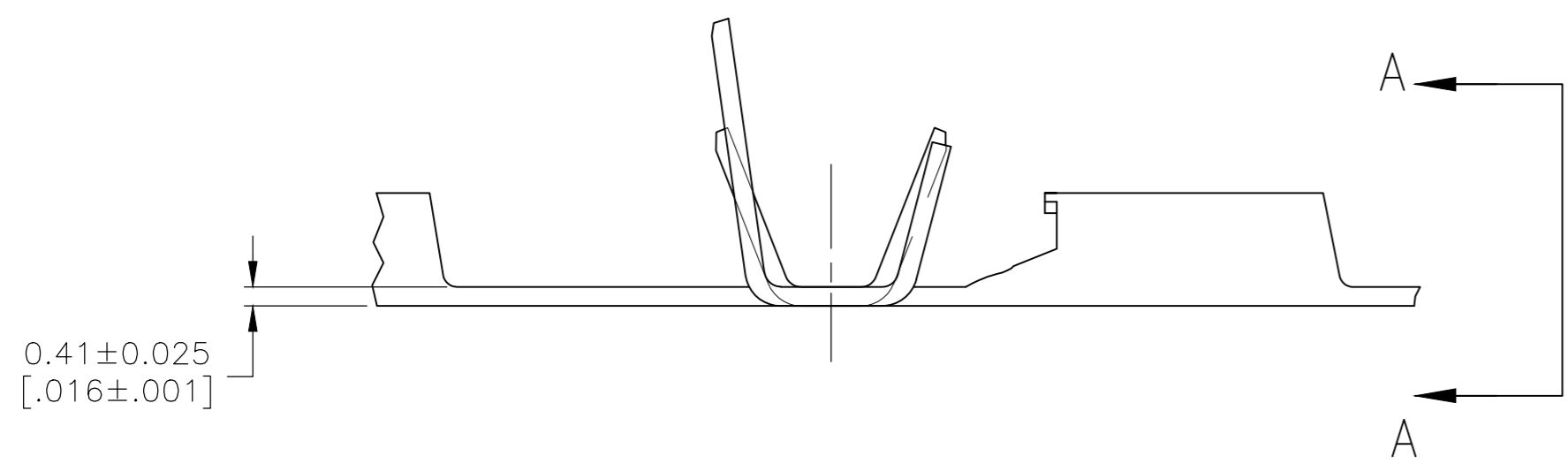

SECTION B-B

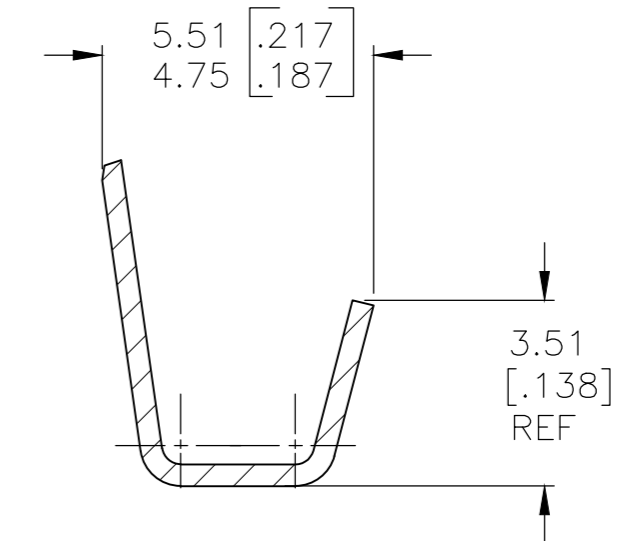

SECTION C-C

PART NO	WIRE		INSULATION DIAMETER (MAX)	WIDTH	WIRE BARREL CRIMP			TENSILE STRENGTH POUNDS
	QTY	SIZE AWG			CRIMP HEIGHT	CRIMPER	ANVIL	
63512-1	1	14	.150	.120	.071	F	FLAT	50
	1	16			.063			30
	1	18			.057			20

OBSOLETE		.000080 MIN TIN	63512-4
	REVERSE REELING	-	63512-3
		-	63512-1
	REELING	FINISH	PART NO.

THIS DRAWING IS A CONTROLLED DOCUMENT.		DWN	JR RUTH	9/29/88		TE Connectivity																		
DIMENSIONS: mm [INCHES]		CHK	MS FEHER	9/30/88		RECEPTACLE, FLAG, FASTON, 4.75 [.187] SERIES																		
TOLERANCES UNLESS OTHERWISE SPECIFIED:		APVD	C MEYERS	9/30/88		-																		
<table border="0"> <tr><td>0 PLC</td><td>±</td><td>-</td></tr> <tr><td>1 PLC</td><td>±</td><td>-</td></tr> <tr><td>2 PLC</td><td>±</td><td>0.25 [.010]</td></tr> <tr><td>3 PLC</td><td>±</td><td>-</td></tr> <tr><td>4 PLC</td><td>±</td><td>-</td></tr> <tr><td>ANGLES</td><td>±</td><td>-</td></tr> </table>		0 PLC	±	-		1 PLC	±	-	2 PLC	±	0.25 [.010]	3 PLC	±	-	4 PLC	±	-	ANGLES	±	-	APPLICATION SPEC		-	
0 PLC	±	-																						
1 PLC	±	-																						
2 PLC	±	0.25 [.010]																						
3 PLC	±	-																						
4 PLC	±	-																						
ANGLES	±	-																						
MATERIAL	BRASS	FINISH	SEE TABLE	WEIGHT	-	SIZE	A2	CAGE CODE	00779	DRAWING NO	C=63512	RESTRICTED TO	-											
CUSTOMER DRAWING				SCALE	4:1	SHEET	1 of 1	REV	K															