

Specification

Date : Mar-22-2012

TO : Digi-Key

Approved by

Selling agency
KYOCERA Corporation
(Electronic Components Sales Division)
〒612-8501 6 Takeda Tobadono-cho, Fushimi-ku
Kyoto 612-8501
TEL 075-604-3500, FAX 075-604-3501

Manufacturer
KYOCERA KINSEKI Corporation
(Crystal Oscillator Department)
〒201-8648 1-8-1 Izumi -Honcho Komae-shi,
Tokyo 201-8648
TEL 03-5497-3111, FAX 03-5497-3209

Let us Submit 1 Copies of the approved Specification on the below items.

Product	SAW Oscillator
Model	KC7050Yxxx.xxxL30EZU (x is frequency.)
Frequency	75.0000, 125.000, 156.250, 200.000, 250.000, 312.500MHz
Customer Model	-
Customer Parts No.	-

This product is Pb - Free and RoHS compliant.

Engineering KYOCERA KINSEKI Yamagata Corporation	Issued by <i>Y. Yamagishi</i>	Approved by <i>N. Takano</i>	Drawing No. K1101-12002-SF2
--------------------------------------------------------	----------------------------------	---------------------------------	--------------------------------

※Recycled paper is being used for the conservation of nature

HISTORY

No	Date	Change matter	Charge	Check	Approval
1	2012/1/6	First edition	<i>Y. Yamagishi</i>	<i>T. Kobayashi</i>	<i>N. Takano</i>
2	2012/3/22	Model KC7050Yxxx.xxxL30E00 → KC7050Yxxx.xxxL30EZU 7-1. Taping Quantities maximum 1000 pcs → maximum 500 pcs	<i>Y. Yamagishi</i>	<i>T. Kobayashi</i>	<i>N. Takano</i>
KYOCERA KINSEKI Yamagata Corporation			Dwg No	K1101-12002-SF2 2/8	

1. Application

This specification delivers Digi-Key.

SAW Oscillator, KC7050Yxxx.xxxL30EZU applies to 75.0000, 125.000, 156.250, 200.000, 250.000, 312.500MHz.

2. Function

2-1. Absolute Maximum Rating

Item	Symbol	Rating	Unit
Power Supply Voltage	V_{CC}	-0.3 to +5.0	V
Input Voltage	V_{IN}	-0.3 to $V_{CC} + 0.3$	V
Storage Temperature Range	T_{STG}	-55 to +125	°C

Note: If KC7050Y is used beyond absolute maximum ratings, it may cause internal destruction.

KC7050Y should be used under the recommended operating conditions. KC7050Y reliability may be damaged if those conditions are exceeded.

2-2. Recommended Operating Condition

Item	Symbol	Min	Typ	Max	Unit	Remarks
Power Supply Voltage	V_{CC}	3.14	3.3	3.46	V	
Input Voltage	V_{IN}	0	---	V_{CC}	V	
Operating Temperature Range	T_{OPR}	0	+25	+70	°C	

2-3. Electrical Characteristic Specifications

Item	Symbol	Min	Typ	Max	Unit	Remarks
Frequency Stability	F_{SBY}	-50	---	+50	ppm	*Over all conditions: Initial tolerance, operating temperature range, rated power supply voltage change, load change, aging (1year @25°C), shock and vibration
Current Consumption	I_{CC}	---	---	70	mA	
Standby Current	I_{ST}	---	---	30	µA	
Duty ratio (crossing point)	SYM	45	50	55	%	100ohm, @ 50% Vopp
Rise Time (20% to 80% Output Level)	T_r	---	0.25	0.4	nS	100ohm
Fall Time (20% to 80% Output Level)	T_f	---	0.25	0.4		
Output Voltage -"L"	V_{OL}	0.9	1.1	---	V	DC characteristic.
Output Voltage -"H"	V_{OH}	---	1.43	1.6		
Differential Output Voltage	V_{OD}	247	330	454	mV	DC characteristic. $dV_{OD} = V_{OD1} - V_{OD2} $
Differential Output Voltage Error	dV_{OD}	---	---	50		
Offset Voltage	V_{OS}	1.125	1.25	1.375	V	
Offset Voltage Error	dV_{OS}	---	---	50	mV	$dV_{OS} = V_{OS1} - V_{OS2} $
Output Load	---	100			ohm	LVDS Output
Input Voltage -"L"	V_{IL}	---	---	30% V_{CC}	V	OE termination
Input Voltage -"H"	V_{IH}	70% V_{CC}	---	---		
Output Disable Time	---	---	---	200	nS	
Output Enable Time	---	---	---	10	mS	
Start up time	ST	---	---	10	mS	@Minimum operating voltage to be 0sec
Deterministic Jitter*	DJ	---	0.2	2	pS	DJ pk-pk
1sigma Jitter*	1sigma	---	2	4		
Peak to Peak Jitter*	Pk-Pk	---	20	30		

Note: All Electrical characteristics define Maximum Loaded and operating temperature range.

*The Time Interval Analyzer "Wavecrest DTS-2079" with VISI 6.3.1 shall measure jitter.

(Load=50ohm, @ 50% output swing)

Table 1

KYOCERA KINSEKI Yamagata
Corporation

Dwg No

K1101-12002-SF2 3/8

2-4. Measurement Condition

Unless otherwise specified, the standard range of atmospheric conditions for making measurements and tests are as follows:

- Ambient temperature : 15°C to 35 °C
- Relative Humidity : 25% to 85%
- Air pressure : 86kPa to 106kPa

If there is any doubt about the results, measurements shall be made within the following limits:

- Ambient temperature : 25°C
- Relative Humidity : 60% to 70%
- Air pressure : 86kPa to 106kPa

Unless otherwise specified for each item, it should be specified according to JIS (Japanese industrial Standard).

2-5. Measurement Circuit

The test circuit as shown in “Fig. 1” (*Jitter Test Circuits “Fig. 4”) shall measure electric characteristics.

2-6. Clock Timing Chart

The clock timing chart as shown in “Fig. 2”, “Fig. 3”..

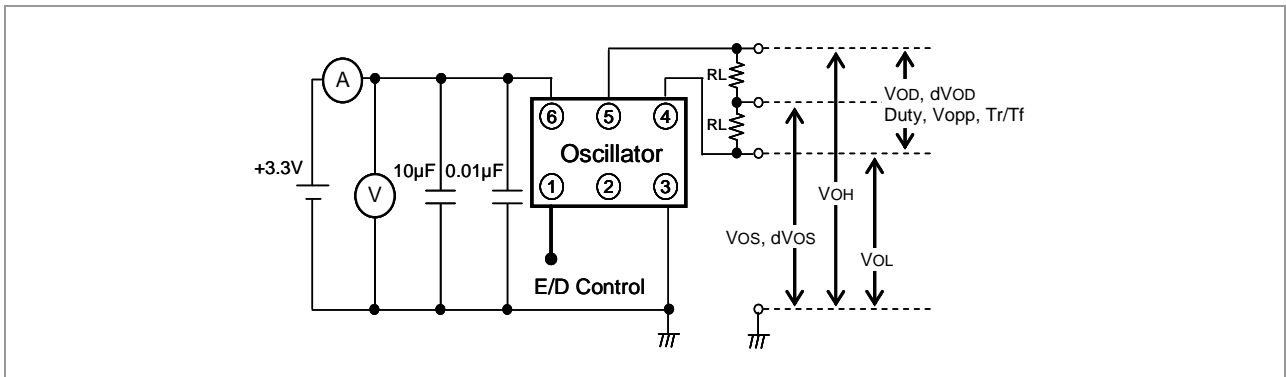

Fig.1 TestCircuit

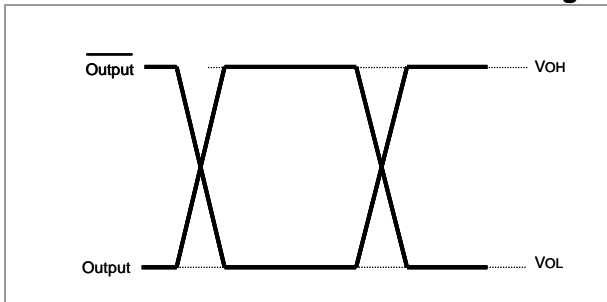

Fig.2 Clock Timing Chart 3

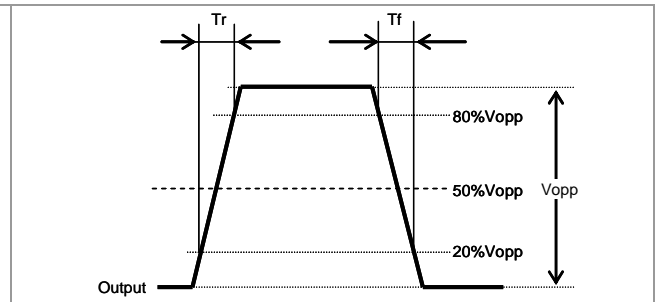

Fig.3 Clock Timing Chart 2

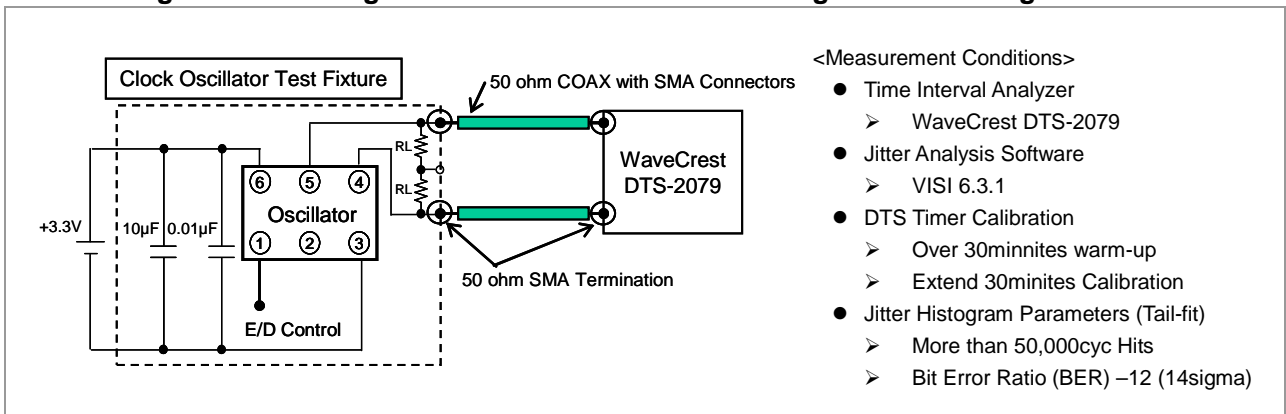
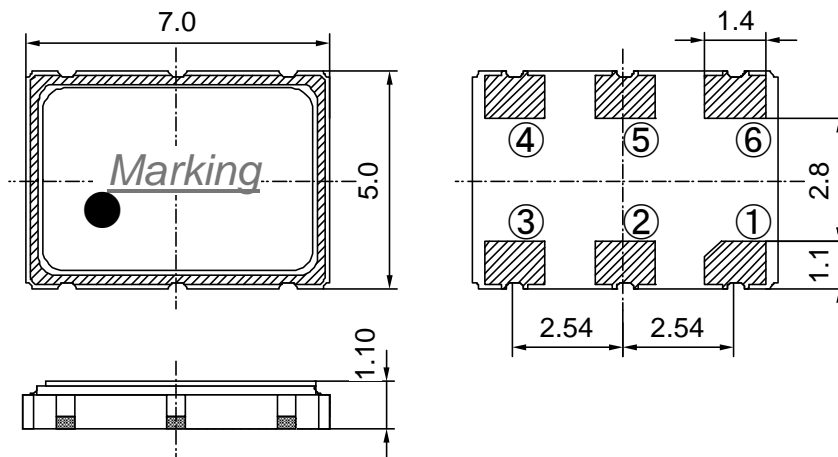

Fig.4 Jitter Test Circuits

<Measurement Conditions>

- Time Interval Analyzer
 - WaveCrest DTS-2079
- Jitter Analysis Software
 - VISI 6.3.1
- DTS Timer Calibration
 - Over 30minites warm-up
 - Extend 30minites Calibration
- Jitter Histogram Parameters (Tail-fit)
 - More than 50,000cyc Hits
 - Bit Error Ratio (BER) -12 (14sigma)

3. Dimensions and Marking



Tolerance; +/-0.2
Unit; (mm)

Pad arrangement	
①	Enable / Disable
②	NC
③	GND
④	Output
⑤	Complementary Output
⑥	V _{CC}

Enable / Disable Function	
*Pad1	*Pad4 / Pad5
OPEN	Active
"H" Level	Active
"L" Level	No-Oscillation

Marking		(Example)																																				
A	Frequency (3digits)																																					
B	Frequency identification code																																					
C	Output Waveform ex; 3[LVDS]																																					
D	Supply Voltage ex; A[3.3V]																																					
E	Multiplying function ex; A[No multiplying], B[1/2], C[1/4]																																					
F	Management No.																																					
G	Pin No.1 indication																																					
H	Making Company Abbreviation																																					
I	Lot code Manufacturing year and week are shown.																																					
<table border="1"> <thead> <tr> <th>code</th> <th>year</th> <th>month</th> <th colspan="7">Week</th> </tr> </thead> <tbody> <tr> <td>201</td> <td rowspan="3">2012</td> <td rowspan="3">1</td> <td></td><td></td><td>1</td><td>2</td><td>3</td><td>4</td><td>5</td> </tr> <tr> <td>202</td> <td>6</td><td>7</td><td>8</td><td>9</td><td>10</td><td>11</td><td>12</td> </tr> <tr> <td>203</td> <td>13</td><td>14</td><td>15</td><td>16</td><td>17</td><td>18</td><td>19</td> </tr> </tbody> </table>		code	year	month	Week							201	2012	1			1	2	3	4	5	202	6	7	8	9	10	11	12	203	13	14	15	16	17	18	19	
code	year	month	Week																																			
201	2012	1			1	2	3	4	5																													
202			6	7	8	9	10	11	12																													
203			13	14	15	16	17	18	19																													
ex; 2012, The first week : 201																																						

4. Parts Numbering Guide

KC7050Y xxx.xxx L 3 0 E ZU

A B C D E F G

A: Series (6pad SMD SAW OSC)

B: Oscillating frequency

C: Output

L [LVDS]

D: Supply voltage

3 [3.3V]

E: Frequency stability (*Over all condition)

0 [±50ppm]

*Over all conditions:

Initial tolerance, operating temperature range, rated power supply voltage change, load change, aging(1year @25°C), shock and vibration.

F: Duty ratio and Enable/Disable function

E [Duty 45% to 50% with standby function]

G: Customer special model suffix

ZU [Custom specification]

KYOCERA KINSEKI Yamagata Corporation

Dwg No

K1101-12002-SF2 5/8

5. Environmental Characterist

Items	Conditions	Criteria of Acceptance
5-1. Solderability	Soaking: 245±5°C, 5.0±0.5sec	Dipped potion: Minimum 95% coverage
5-2. Soldering Heat Resistance	Reflow Soldering: Peak 260°C max, 10sec, Twice max Soldering iron: 380±5°C, 3+1/-0sec, Twice as one time for four Pads	Without looseness or crack etc.
5-3. Temperature Cycle	10Cycles: -55°C to +125°C (30minuts each)/cycle	Clause 5-10 shall be satisfied.
5-4. Mechanical Shock (Pulse)	5 times 14750m/sec ² (1500G), Duration of pulse 0.5msec (MIL-STD-883D-2002.3 Condition B)	
5-5. Vibration	4 times each axis X, Y, Z: 20 to 2000Hz and 2000Hz to 20Hz/cycle Peak acceleration 196m/sec ² (20G) (MIL-STD-883D-2007.2 Condition A)	
5-6. High Temperature	1000 hours: Temperature: 85+5/-3°C	
5-7. Low Temperature	1000 hours: Temperature: -40+5/-3°C	
5-8. Humidity Cycle	10 cycles: Based on 1004 specifications (MIL-STD-883D-1004.7)	Clause 5-1 shall be satisfied.
5-9. Hermeticity 1 (Gross leak)	Soaking: 110±5°C, 5minutes	No bubbles appeared
5-10. Hermeticity 2 (Fine leak)	Measured by Helium Detector Device (MIL-STD-883D-1014.10 Condition A1)	5x10 ⁻⁹ Pa m ³ /sec max

Note:After above Test, it shall be subjected to standard atmospheric conditions for 2 hours, after which measurement shall be made. And result of the test shall satisfy **Table 1**

Table2

6. Recommended Land pattern and soldering Guide

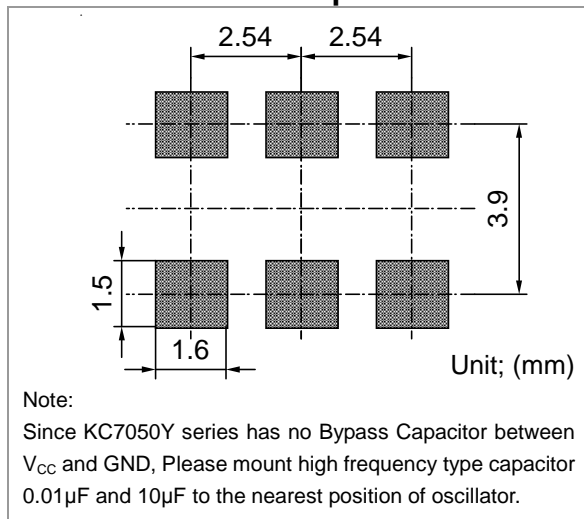

Fig.4 Land pattern

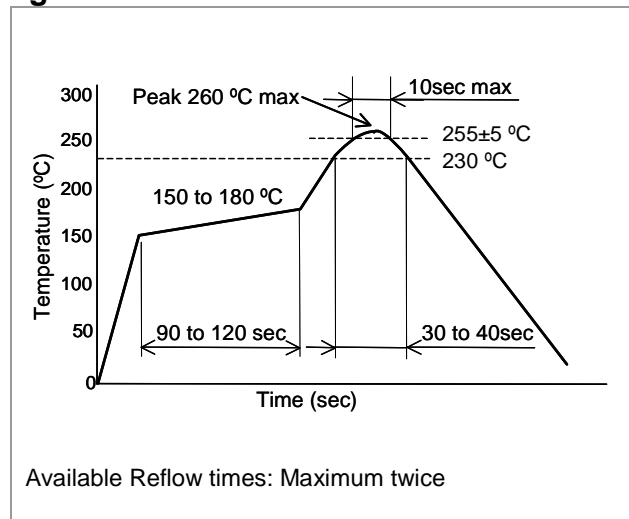

Fig.5 Reflow profile (Lead Free Available)

<Reflow Condition>

- Solder melting point 183°C

<Solder Heat Resistance>

- Maximum 260°C / Maximum 10sec or Maximum 230°C / Maximum 60sec.

KYOCERA KINSEKI Yamagata
Corporation

Dwg No

K1101-12002-SF2 6/8

7. Taping Specifications

7-1. Taping Quantities:

- The tape of one reel shall pack with maximum 500 pcs.
- KC7050Y shall be contained continuously in pocket.

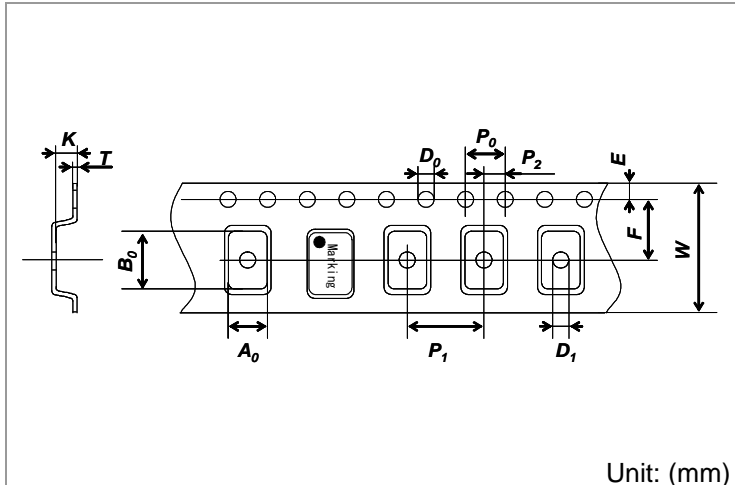

Unit: (mm)

Symbol	A_0	B_0	W	F	E
Dimensions	5.6 ± 0.1	7.8 ± 0.1	16.0 ± 0.3	7.5 ± 0.1	1.75 ± 0.1
Symbol	P_1	P_2	P_0	D_0	T
Dimensions	8.0 ± 0.1	2.0 ± 0.1	4.0 ± 0.1	$1.5 + 0.1/0$	0.3 ± 0.05
Symbol	K	D_1			
Dimensions	1.9 ± 0.1	1.55 ± 0.05			

Fig.6 Emboss Carrier

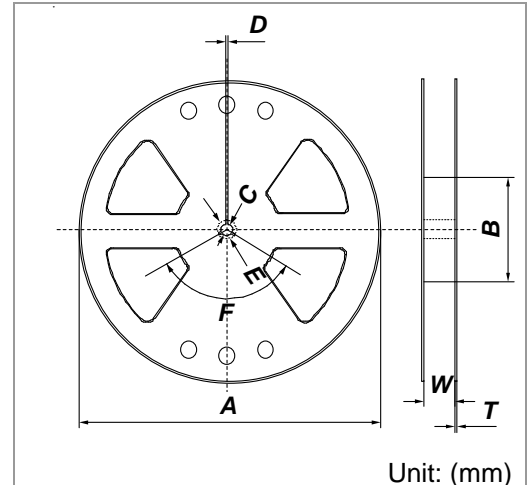

Unit: (mm)

Symbol	A	B	C
Dimensions	$\phi 330 \pm 2$	$\phi 100 \pm 1$	$\phi 13 \pm 2$
Symbol	D	E	F
Dimensions	2.0 ± 0.5	$\phi 21 \pm 0.8$	120°
Symbol	W	T	
Dimensions	17.5 ± 0.5	2 ± 0.5	

Fig.7 Reel

7-2. Leader and Blank Pocket

- Package shall consist of leader, blank pocket and loaded pocket as follows. "Fig.8"
- The power peeling top tape from carrier one shall be $0.1N$ {10gf} to $0.7N$ {70gf}. "Fig.9"

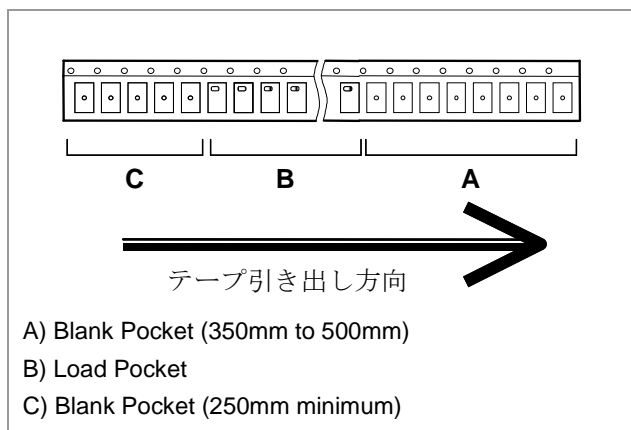

Fig.8 Taping

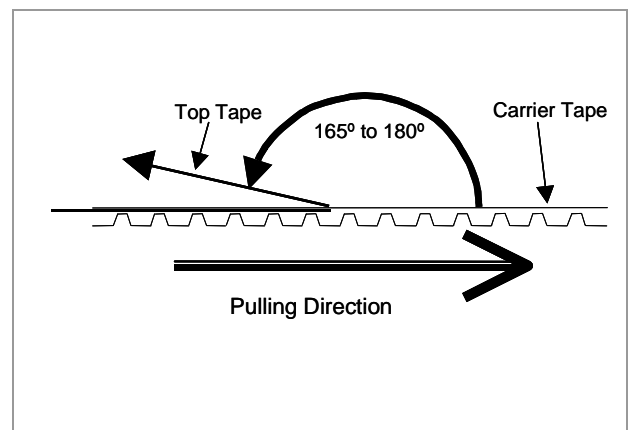

Fig.9 Peeling Strength

8. Package

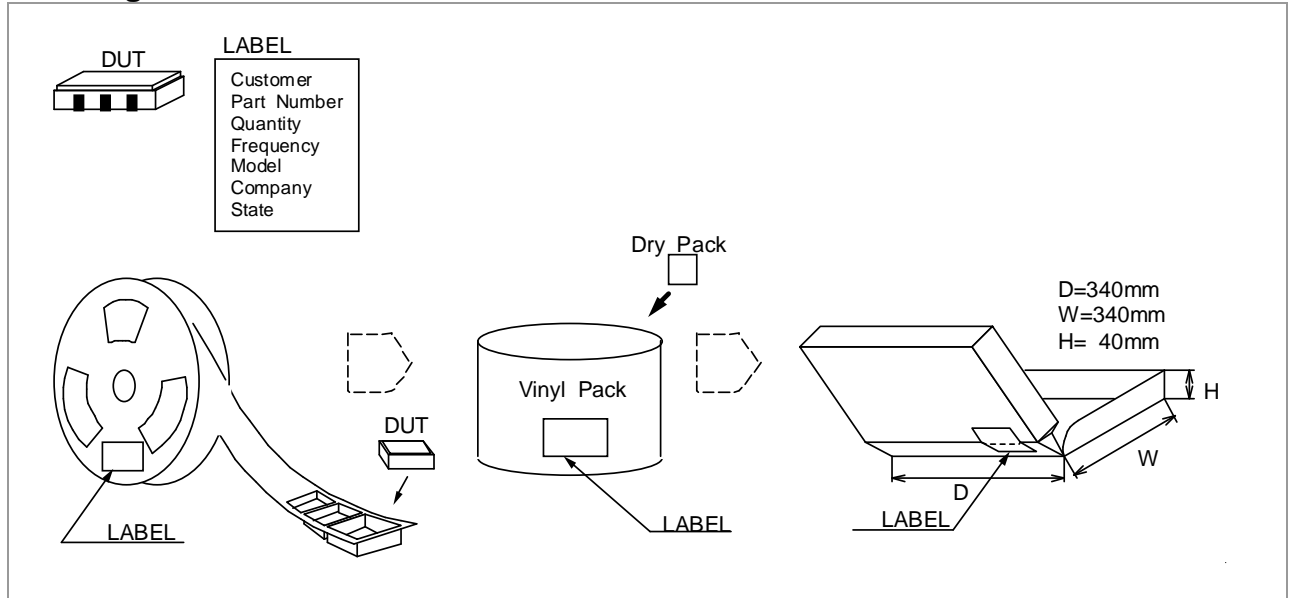

Fig.10 Package

9. The agreement of this specifications

If you find further points in this specifications, contact us within 45 days after the date of issue.

10. Remarks on Usage

10-1. Storage Condition

Parts should be stored in temperature range of -5 to +40°C, humidity 40 to 60% RH, and avoid direct sunlight. Then use within 6 months.

10-2. Handling Condition

Although KC7050Y has protection circuit against static electricity, when excess static electricity is applied, the inside IC may get damaged.

When mounting on PCB, please make sure the direction of KC7050Y is correct, otherwise KC7050Y will increase in temperature and may damaged.

Please do not use KC7050Y under unfavorable condition such as beyond specified range in catalogue or specification sheet.

When using an auto-mounting machine, select the one which give silent impulse as little as possible to the relevant components and operate it with much attentive confirmation so that it may not cause damaged.

After making the KC7050Y mounted on a printed circuit board, if it is required to divide the printed circuit board into another one, use it with attentive confirmation so that a warp caused by this division might not affect any damage. When designing a printed circuit board as well as handling the mounting location, the printed circuit board has to be being stress free area as much as possible.

Please do not use KC7050Y under condition in the water or salt water will drop on KC7050Y and under environment of dew or harmful gas.

10-3. Soldering

Please use KC7050Y under condition " IR or Vapor phase Reflow " only.

10-4. Washing Condition

If KC7050Y is applied ultrasonic, it may be inferior and destroy.

Please don't use ultrasonic cleaner.

In case of using KC7050Y without above precaution, Kyocera is unable to guarantee the specified characteristics.