

# NCV1124

## Dual Variable-Reluctance Sensor Interface IC

The NCV1124 is a monolithic integrated circuit designed primarily to condition signals from sensors used to monitor rotating parts.

The NCV1124 is a dual channel device. Each of the two identical channels interfaces with a variable-reluctance sensor, and continuously compares the sensor output signal to a user-programmable internal reference. An alternating input signal of appropriate amplitude at IN1 or IN2 will result in a rectangular waveform at the corresponding OUT terminal, suitable for interface to either standard microprocessors or standard logic families.

A diagnostic input, common to both channels, provides a means to test for degradation or loss of the physical connector to both sensors.

### Typical Applications

- Anti-Skid Braking and Traction Control
- Vehicle Stability Control
- Drive Belt Slippage Detection
- Crankshaft/Camshaft Position Sensing

### Features

- Two Independent Channels
- Internal Hysteresis
- Built-In Diagnostic Mode
- Designed to Work from a 5.0 V  $\pm$  10% Supply
- Site and Control for Automotive Applications
- Pb-Free Packages are Available

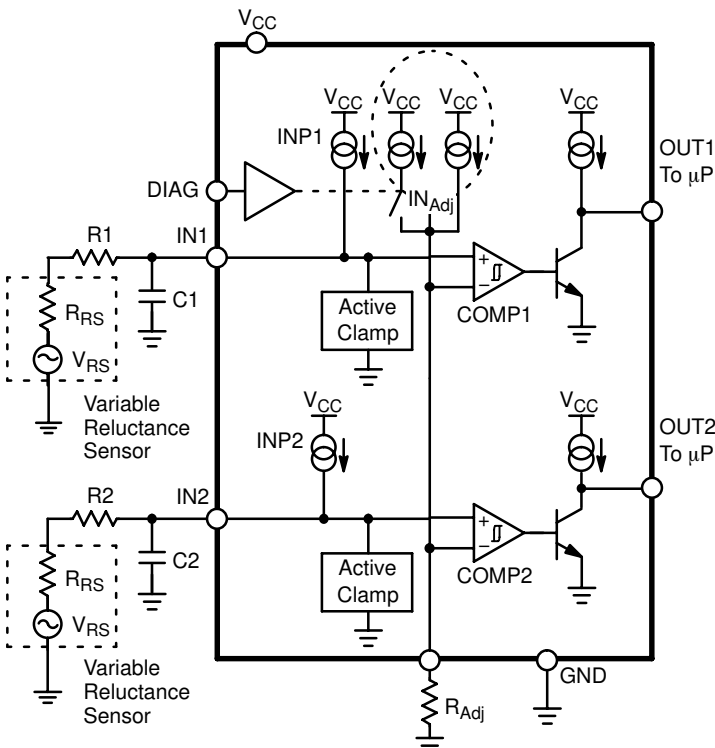

Figure 1. Block Diagram



ON Semiconductor®

<http://onsemi.com>



SO-8  
CASE 751

### MARKING DIAGRAM

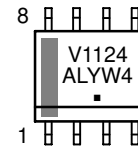

V1124 = Device Code  
A = Assembly Location  
L = Wafer Lot  
Y = Year  
W = Work Week  
▪ = Pb-Free Package

### PIN CONNECTIONS

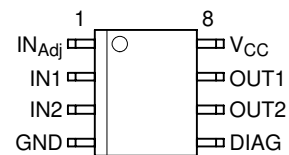

### ORDERING INFORMATION

See detailed ordering and shipping information in the package dimensions section on page 3 of this data sheet.

# NCV1124

## MAXIMUM RATINGS

Rating	Value	Unit
Storage Temperature Range	-65 to 150	°C
Ambient Operating Temperature	-40 to 125	°C
Supply Voltage Range (continuous)	-0.3 to 7.0	V
Input Voltage Range (at any input, R1 = R2 = 22 k)	-250 to 250	V
Maximum Junction Temperature	150	°C
ESD Susceptibility (Human Body Model)	2.0	kV
Lead Temperature Soldering:	Reflow: (SMD styles only) (Note 1)	240 peak
		°C

Stresses exceeding Maximum Ratings may damage the device. Maximum Ratings are stress ratings only. Functional operation above the Recommended Operating Conditions is not implied. Extended exposure to stresses above the Recommended Operating Conditions may affect device reliability.

1. 60 second maximum above 183°C.

## ELECTRICAL CHARACTERISTICS (4.5 V < V<sub>CC</sub> < 5.5 V, -40°C < T<sub>A</sub> < 125°C, V<sub>DIAG</sub> = 0; unless otherwise specified.)

Characteristic	Test Conditions	Min	Typ	Max	Unit
----------------	-----------------	-----	-----	-----	------

### V<sub>CC</sub> SUPPLY

Operating Current Supply	V <sub>CC</sub> = 5.0 V	-	-	5.0	mA
--------------------------	-------------------------	---	---	-----	----

### Sensor Inputs

Input Threshold – Positive	V <sub>DIAG</sub> = Low	135	160	185	mV
	V <sub>DIAG</sub> = High	135	160	185	mV
Input Threshold – Negative	V <sub>DIAG</sub> = Low	-185	-160	-135	mV
	V <sub>DIAG</sub> = High	135	160	185	mV
Input Bias Current (INP1, INP2)	V <sub>IN</sub> = 0.336 V	-16	-11	-6.0	μA
Input Bias Current (DIAG)	V <sub>DIAG</sub> = 0 V	-	-	1.0	μA
Input Bias Current Factor (K <sub>I</sub> ) (I <sub>NAdj</sub> = INP × K <sub>I</sub> )	V <sub>IN</sub> = 0.336 V, V <sub>DIAG</sub> = Low	-	100	-	%INP
	V <sub>IN</sub> = 0.336 V, V <sub>DIAG</sub> = High	152	155	157	%INP
Bias Current Matching	INP1 or INP2 to I <sub>NAdj</sub> , V <sub>IN</sub> = 0.336 V	-1.0	0	1.0	μA
Input Clamp – Negative	I <sub>IN</sub> = -50 μA	-0.5	-0.25	0	V
	I <sub>IN</sub> = -12 mA	-0.5	-0.30	0	V
Input Clamp – Positive	I <sub>IN</sub> = +12 mA	5.0	7.0	9.8	V
Output Low Voltage	I <sub>OUT</sub> = 1.6 mA	-	0.2	0.4	V
Output High Voltage	I <sub>OUT</sub> = -1.6 mA	V <sub>CC</sub> - 0.5	V <sub>CC</sub> - 0.2	-	V
Mode Change Time Delay	-	0	-	20	μs
Input to Output Delay	I <sub>OUT</sub> = 1.0 mA	-	1.0	20	μs
Output Rise Time	C <sub>LOAD</sub> = 30 pF	-	0.5	2.0	μs
Output Fall Time	C <sub>LOAD</sub> = 30 pF	-	0.05	2.0	μs
Open-Sensor Positive Threshold	V <sub>DIAG</sub> = High, R <sub>IN(Adj)</sub> = 40 k. Note 2	29.4	54	86.9	kΩ

### Logic Inputs

DIAG Input Low Threshold	-	-	-	0.2 × V <sub>CC</sub>	V
DIAG Input High Threshold	-	0.7 × V <sub>CC</sub>	-	-	V
DIAG Input Resistance	V <sub>IN</sub> = 0.3 × V <sub>CC</sub> , V <sub>CC</sub> = 5.0 V	8.0	22	70	kΩ
	V <sub>IN</sub> = V <sub>CC</sub> , V <sub>CC</sub> = 5.0 V	8.0	22	70	kΩ

2. This parameter is guaranteed by design, but not parametrically tested in production.

# NCV1124

## PACKAGE PIN DESCRIPTION

PIN # SO-8	PIN SYMBOL	FUNCTION
1	IN <sub>Adj</sub>	External resistor to ground that sets the trip levels of both channels. Functions for both diagnostic and normal mode
2	IN1	Input to channel 1
3	IN2	Input to channel 2
4	GND	Ground
5	DIAG	Diagnostic mode switch. Normal mode is low
6	OUT2	Output of channel 2
7	OUT1	Output of channel 1
8	V <sub>CC</sub>	Positive 5.0 volt supply input

## ORDERING INFORMATION

Device	Package	Shipping†
NCV1124DG	SO-8 NB (Pb-Free)	98 Units / Rail
NCV1124DR2G	SO-8 NB (Pb-Free)	2500 Units / Tape & Reel

†For information on tape and reel specifications, including part orientation and tape sizes, please refer to our Tape and Reel Packaging Specifications Brochure, BRD8011/D.

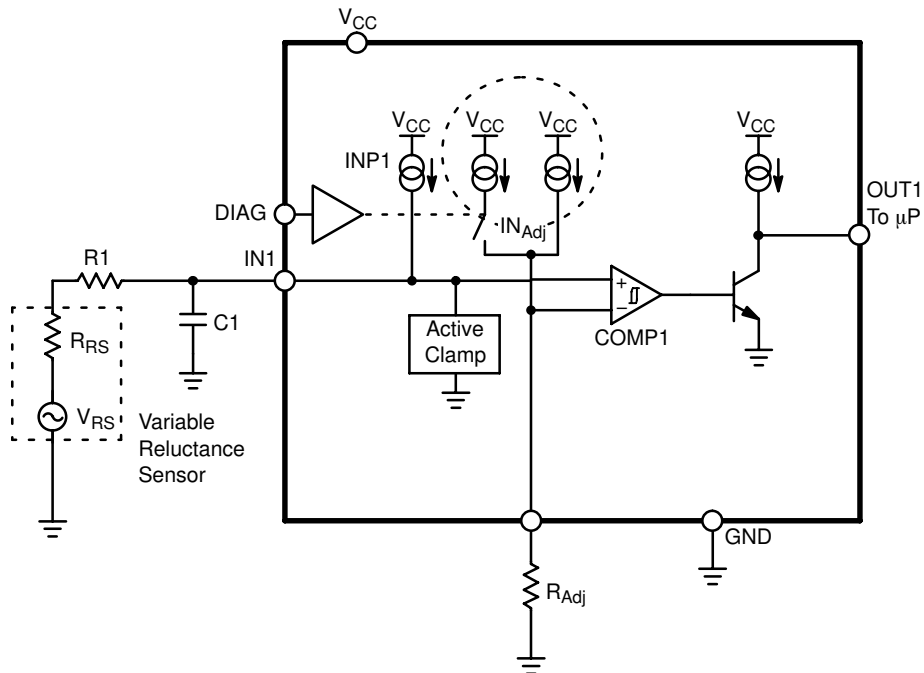

Figure 2. Application Diagram

THEORY OF OPERATION

NORMAL OPERATION

Figure 2 shows one channel of the NCV1124 along with the necessary external components. Both channels share the  $IN_{Adj}$  pin as the negative input to a comparator. A brief description of the components is as follows:

$V_{RS}$  – Ideal sinusoidal, ground referenced, sensor output – amplitude usually increases with frequency, depending on loading.

$R_{RS}$  – Source impedance of sensor.

$R1/R_{Adj}$  – External resistors for current limiting and biasing.

$INP1/IN_{Adj}$  – Internal current sources that determine trip points via  $R1/R_{Adj}$ .

COMP1 – Internal comparator with built-in hysteresis set at 160 mV.

OUT1 – Output 0 V – 5.0 V square wave with the same frequency as  $V_{RS}$ .

By inspection, the voltage at the (+) and (–) terminals of COMP1 with  $V_{RS} = 0V$  are:

$$V^+ = INP1(R1 + R_{RS}) \quad (1)$$

$$V^- = IN_{Adj} \times R_{Adj} \quad (2)$$

As  $V_{RS}$  begins to rise and fall, it will be superimposed on the DC biased voltage at  $V^+$ .

$$V^+ = INP1(R1 + R_{RS}) + V_{RS} \quad (3)$$

To get comparator COMP1 to trip, the following condition is needed when crossing in the positive direction,

$$V^+ > V^- + V_{HYS} \quad (4)$$

( $V_{HYS}$  is the built-in hysteresis set to 160 mV), or when crossing in the negative direction,

$$V^+ < V^- - V_{HYS} \quad (5)$$

Combining equations 2, 3, and 4, we get:

$$INP1(R1 + R_{RS}) + V_{RS} > IN_{Adj} \times R_{Adj} + V_{HYS} \quad (6)$$

therefore,

$$V_{RS(+TRP)} < IN_{Adj} \times R_{Adj} - INP1(R1 + R_{RS}) + V_{HYS} \quad (7)$$

It should be evident that tripping on the negative side is:

$$V_{RS(-TRP)} < IN_{Adj} \times R_{Adj} - INP1(R1 + R_{RS}) - V_{HYS} \quad (8)$$

In normal mode,

$$INP1 = IN_{Adj} \quad (9)$$

We can now re-write equation (7) as:

$$V_{RS(+TR)} > INP1(R_{Adj} - R1 - R_{RS}) + V_{HYS} \quad (10)$$

By making

$$R_{Adj} = R1 + R_{RS} \quad (11)$$

you can detect signals with as little amplitude as  $V_{HYS}$ .

A design example is given in the applications section.

OPEN SENSOR PROTECTION

The NCV1124 has a DIAG pin that when pulled high (5.0 V), will increase the  $IN_{Adj}$  current source by roughly 50%.

Equation (7) shows that a larger  $V_{RS(+TRP)}$  voltage will be needed to trip comparator COMP1. However, if no  $V_{RS}$  signal is present, then we can use equations 1, 2, and 4 (equation 5 does not apply in this mode) to get:

$$INP1(R1 + R_{RS}) > INP1 \times K_I \times R_{Adj} + V_{HYS} \quad (12)$$

Since  $R_{RS}$  is the only unknown variable we can solve for  $R_{RS}$ ,

$$R_{RS} = \frac{INP1 \times K_I \times R_{Adj} + V_{HYS}}{INP1} - R1 \quad (13)$$

Equation (13) shows that if the output switches states when entering the diag mode with  $V_{RS} = 0$ , the sensor impedance must be greater than the above calculated value. This can be very useful in diagnosing intermittent sensor.

INPUT PROTECTION

As shown in Figure 2, an active clamp is provided on each input to limit the voltage on the input pin and prevent substrate current injection. The clamp is specified to handle  $\pm 12$  mA. This puts an upper limit on the amplitude of the sensor output. For example, if  $R1 = 20$  k, then

$$V_{RS(MAX)} = 20 \text{ k} \times 12 \text{ mA} = 240 \text{ V}$$

Therefore, the  $V_{RS(pk-pk)}$  voltage can be as high as 480 V.

The NCV1124 will typically run at a frequency up to 1.8 MHz if the input signal does not activate the positive or negative input clamps. Frequency performance will be lower when the positive or negative clamps are active. Typical performance will be up to a frequency of 680 kHz with the clamps active.

CIRCUIT DESCRIPTION

Figure 3 shows the part operating near the minimum input thresholds. As the sin wave input threshold is increased, the low side clamps become active (Figure 4). Increasing the amplitude further (Figure 5), the high-side clamp becomes active. These internal clamps allow for voltages up to -250 V and 250 V on the sensor side of the setup (with  $R1 = R2 = 22\text{ k}$ ) (reference the diagram page 1).

Figure 6 shows the effect using the diagnostic (DIAG) function has on the circuit. The input threshold (negative) is switched from a threshold of -160 mV to +160 mV when DIAG goes from a low to a high. There is no hysteresis when DIAG is high.

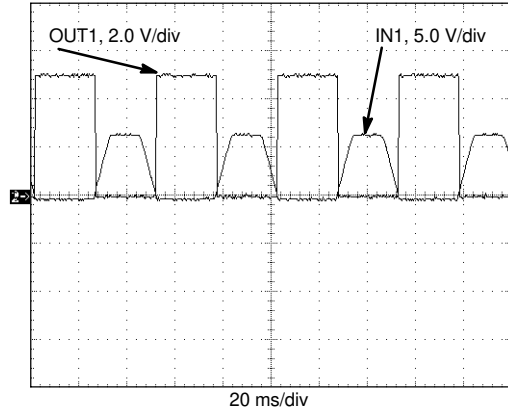

Figure 5. Low- and High-Side Clamps

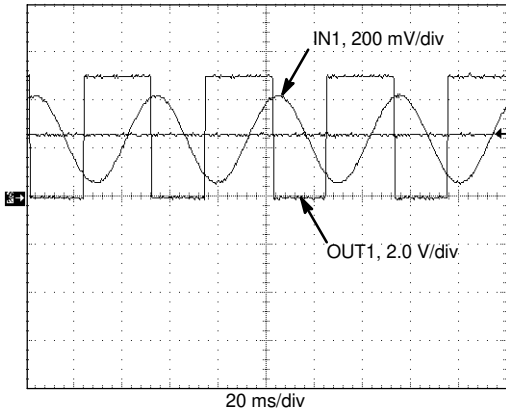

Figure 3. Minimum Threshold Operation

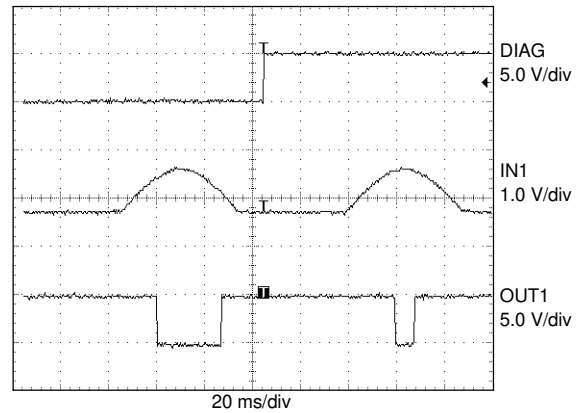

Figure 6. Diagnostic Operation

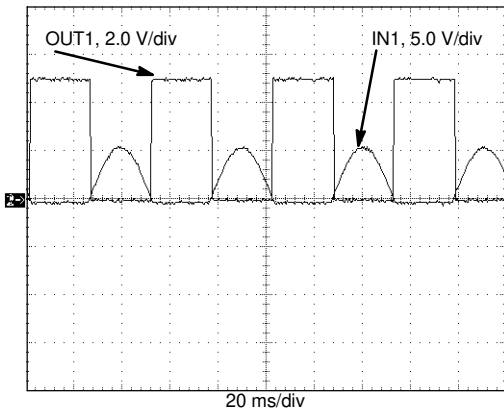

Figure 4. Low-Side Clamp

APPLICATION INFORMATION

Referring to Figure 2, the following will be a design example given these system requirements:

$$R_{RS} = 1.5 \text{ k}\Omega \text{ (} > 12 \text{ k}\Omega \text{ is considered open)}$$

$$V_{RS(MAX)} = 120 \text{ V}_{pk}$$

$$V_{RS(MIN)} = 250 \text{ mV}_{pk}$$

$$F_{VRS} = 10 \text{ kHz @ } V_{RS(MIN)} = 40 \text{ V}_{pk-pk}$$

**1. Determine tradeoff between R1 value and power rating. (use 1/2 watt package)**

$$P_D = \frac{\left(\frac{120}{\sqrt{2}}\right)^2}{R_1} < 1/2 \text{ W}$$

Set R1 = 15 k. (The clamp current will then be 120/15 k = 8.0 mA, which is less than the 12 mA limit.)

**2. Determine R<sub>Adj</sub>**

Set R<sub>Adj</sub> as close to R1 + R<sub>RS</sub> as possible.  
Therefore, R<sub>Adj</sub> = 17 k.

**3. Determine V<sub>RS(+TRP)</sub> using equation (7).**

$$V_{RS(+TRP)} = 11\mu\text{A} \times 17 \text{ k} - 11\mu\text{A}(15 \text{ k} + 1.5 \text{ k}) + 160 \text{ mV}$$

$$V_{RS(+TRP)} = 166 \text{ mV typical (easily meets 250 mV minimum)}$$

**4. Calculate worst case V<sub>RS(+TRP)</sub>**

Examination of equation (7) and the spec reveals the worst case trip voltage will occur when:

- V<sub>HYS</sub> = 180 mV
- IN<sub>Adj</sub> = 16 μA
- INP1 = 15 μA
- R1 = 14.25 k (5% low)
- R<sub>Adj</sub> = 17.85 k (5% High)

$$\begin{aligned} V_{RS(+)}MAX &= 16 \mu\text{A}(17.85 \text{ k}) \\ &\quad - 15\mu\text{A}(14.25 \text{ k} + 1.5 \text{ k}) + 180 \text{ mV} \\ &= 229 \text{ mV} \end{aligned}$$

which is still less than the 250 mV minimum amplitude of the input.

**5. Calculate C1 for low pass filtering**

Since the sensor guarantees 40 V<sub>pk-pk</sub> @ 10 kHz, a low pass filter using R1 and C1 can be used to eliminate high frequency noise without affecting system performance.

$$\text{Gain Reduction} = \frac{0.29 \text{ V}}{20 \text{ V}} = 0.0145 = -36.7 \text{ dB}$$

Therefore, a cut-off frequency, f<sub>C</sub>, of 145 Hz could be used.

$$C_1 \leq \frac{1}{2\pi f_C R_1} \leq 0.07 \mu\text{F}$$

Set C1 = 0.047 μF.

**6. Calculate the minimum R<sub>RS</sub> that will be indicated as an open circuit. (DIAG = 5.0 V)**

Rearranging equation (7) gives

$$R_{RS} = \frac{\left[ V_{HYS} + [INP1 \times K_I \times R_{Adj}] - V_{RS(+TRP)} \right]}{INP1} - R_1$$

But, V<sub>RS</sub> = 0 during this test, so it drops out.  
Using the following as worst case Low and High:

	Worst Case Low (R <sub>RS</sub> )	Worst Case High (R <sub>RS</sub> )
IN <sub>Adj</sub>	23.6 μA = 15 μA × 1.57	10.7 μA = 7.0 μA × 1.53
R <sub>Adj</sub>	16.15 k	17.85 k
V <sub>HYS</sub>	135 mV	185 mV
INP1	16 μA	6.0 μA
R1	15.75 k	14.25 k
K <sub>I</sub>	1.57	1.53

$$\begin{aligned} R_{RS} &= \frac{135 \text{ mV} + 23.6 \mu\text{A} \times 16.15 \text{ k}}{16 \mu\text{A}} - 15.75 \text{ k} \\ &= 16.5 \text{ k} \end{aligned}$$

Therefore,

$$R_{RS(MIN)} = 16.5 \text{ k (meets 12 k system spec)}$$

and,

$$\begin{aligned} R_{RS(MAX)} &= \frac{185 \text{ mV} + 10.7 \mu\text{A} \times 17.85 \text{ k}}{6.0 \mu\text{A}} - 14.25 \text{ k} \\ &= 48.4 \text{ k} \end{aligned}$$

# MECHANICAL CASE OUTLINE PACKAGE DIMENSIONS

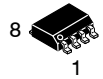

SCALE 1:1

SOIC-8 NB  
CASE 751-07  
ISSUE AK

DATE 16 FEB 2011

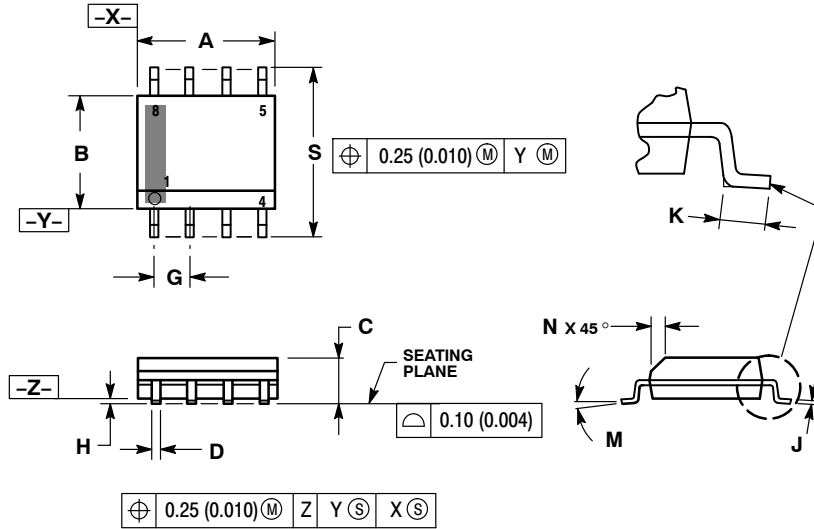

- NOTES:
1. DIMENSIONING AND TOLERANCING PER ANSI Y14.5M, 1982.
  2. CONTROLLING DIMENSION: MILLIMETER.
  3. DIMENSION A AND B DO NOT INCLUDE MOLD PROTRUSION.
  4. MAXIMUM MOLD PROTRUSION 0.15 (0.006) PER SIDE.
  5. DIMENSION D DOES NOT INCLUDE DAMBAR PROTRUSION. ALLOWABLE DAMBAR PROTRUSION SHALL BE 0.127 (0.005) TOTAL IN EXCESS OF THE D DIMENSION AT MAXIMUM MATERIAL CONDITION.
  6. 751-01 THRU 751-06 ARE OBSOLETE. NEW STANDARD IS 751-07.

DIM	MILLIMETERS		INCHES	
	MIN	MAX	MIN	MAX
A	4.80	5.00	0.189	0.197
B	3.80	4.00	0.150	0.157
C	1.35	1.75	0.053	0.069
D	0.33	0.51	0.013	0.020
G	1.27 BSC		0.050 BSC	
H	0.10	0.25	0.004	0.010
J	0.19	0.25	0.007	0.010
K	0.40	1.27	0.016	0.050
M	0°	8°	0°	8°
N	0.25	0.50	0.010	0.020
S	5.80	6.20	0.228	0.244

### SOLDERING FOOTPRINT\*

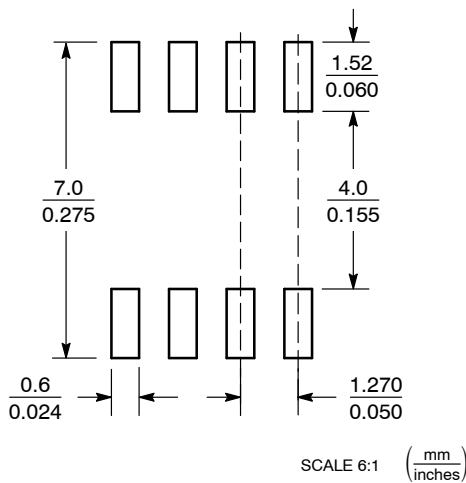

\*For additional information on our Pb-Free strategy and soldering details, please download the ON Semiconductor Soldering and Mounting Techniques Reference Manual, SOLDERRM/D.

### GENERIC MARKING DIAGRAM\*

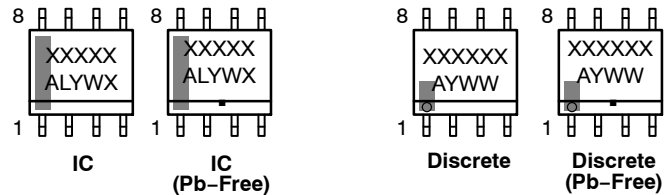

XXXXXX = Specific Device Code  
A = Assembly Location  
L = Wafer Lot  
Y = Year  
W = Work Week  
▪ = Pb-Free Package

XXXXXX = Specific Device Code  
A = Assembly Location  
Y = Year  
WW = Work Week  
▪ = Pb-Free Package

\*This information is generic. Please refer to device data sheet for actual part marking. Pb-Free indicator, "G" or microdot "▪", may or may not be present. Some products may not follow the Generic Marking.

STYLES ON PAGE 2

DOCUMENT NUMBER:	98ASB42564B	Electronic versions are uncontrolled except when accessed directly from the Document Repository. Printed versions are uncontrolled except when stamped "CONTROLLED COPY" in red.
DESCRIPTION:	SOIC-8 NB	PAGE 1 OF 2

onsemi and ONsemi are trademarks of Semiconductor Components Industries, LLC dba onsemi or its subsidiaries in the United States and/or other countries. onsemi reserves the right to make changes without further notice to any products herein. onsemi makes no warranty, representation or guarantee regarding the suitability of its products for any particular purpose, nor does onsemi assume any liability arising out of the application or use of any product or circuit, and specifically disclaims any and all liability, including without limitation special, consequential or incidental damages. onsemi does not convey any license under its patent rights nor the rights of others.

**SOIC-8 NB**  
**CASE 751-07**  
**ISSUE AK**

DATE 16 FEB 2011

- |   |  |  |  |
|---|--|--|--|
| <p>STYLE 1:<br/>         PIN 1. EMITTER<br/>         2. COLLECTOR<br/>         3. COLLECTOR<br/>         4. EMITTER<br/>         5. EMITTER<br/>         6. BASE<br/>         7. BASE<br/>         8. EMITTER</p>   | <p>STYLE 2:<br/>         PIN 1. COLLECTOR, DIE, #1<br/>         2. COLLECTOR, #1<br/>         3. COLLECTOR, #2<br/>         4. COLLECTOR, #2<br/>         5. BASE, #2<br/>         6. EMITTER, #2<br/>         7. BASE, #1<br/>         8. EMITTER, #1</p>               | <p>STYLE 3:<br/>         PIN 1. DRAIN, DIE #1<br/>         2. DRAIN, #1<br/>         3. DRAIN, #2<br/>         4. DRAIN, #2<br/>         5. GATE, #2<br/>         6. SOURCE, #2<br/>         7. GATE, #1<br/>         8. SOURCE, #1</p>                            | <p>STYLE 4:<br/>         PIN 1. ANODE<br/>         2. ANODE<br/>         3. ANODE<br/>         4. ANODE<br/>         5. ANODE<br/>         6. ANODE<br/>         7. ANODE<br/>         8. COMMON CATHODE</p>   |
| <p>STYLE 5:<br/>         PIN 1. DRAIN<br/>         2. DRAIN<br/>         3. DRAIN<br/>         4. DRAIN<br/>         5. GATE<br/>         6. GATE<br/>         7. SOURCE<br/>         8. SOURCE</p>   | <p>STYLE 6:<br/>         PIN 1. SOURCE<br/>         2. DRAIN<br/>         3. DRAIN<br/>         4. SOURCE<br/>         5. SOURCE<br/>         6. GATE<br/>         7. GATE<br/>         8. SOURCE</p>  | <p>STYLE 7:<br/>         PIN 1. INPUT<br/>         2. EXTERNAL BYPASS<br/>         3. THIRD STAGE SOURCE<br/>         4. GROUND<br/>         5. DRAIN<br/>         6. GATE 3<br/>         7. SECOND STAGE Vd<br/>         8. FIRST STAGE Vd</p>                    | <p>STYLE 8:<br/>         PIN 1. COLLECTOR, DIE #1<br/>         2. BASE, #1<br/>         3. BASE, #2<br/>         4. COLLECTOR, #2<br/>         5. COLLECTOR, #2<br/>         6. EMITTER, #2<br/>         7. EMITTER, #1<br/>         8. COLLECTOR, #1</p>                              |
| <p>STYLE 9:<br/>         PIN 1. EMITTER, COMMON<br/>         2. COLLECTOR, DIE #1<br/>         3. COLLECTOR, DIE #2<br/>         4. EMITTER, COMMON<br/>         5. EMITTER, COMMON<br/>         6. BASE, DIE #2<br/>         7. BASE, DIE #1<br/>         8. EMITTER, COMMON</p> | <p>STYLE 10:<br/>         PIN 1. GROUND<br/>         2. BIAS 1<br/>         3. OUTPUT<br/>         4. GROUND<br/>         5. GROUND<br/>         6. BIAS 2<br/>         7. INPUT<br/>         8. GROUND</p>  | <p>STYLE 11:<br/>         PIN 1. SOURCE 1<br/>         2. GATE 1<br/>         3. SOURCE 2<br/>         4. GATE 2<br/>         5. DRAIN 2<br/>         6. DRAIN 2<br/>         7. DRAIN 1<br/>         8. DRAIN 1</p>   | <p>STYLE 12:<br/>         PIN 1. SOURCE<br/>         2. SOURCE<br/>         3. SOURCE<br/>         4. GATE<br/>         5. DRAIN<br/>         6. DRAIN<br/>         7. DRAIN<br/>         8. DRAIN</p>   |
| <p>STYLE 13:<br/>         PIN 1. N.C.<br/>         2. SOURCE<br/>         3. SOURCE<br/>         4. GATE<br/>         5. DRAIN<br/>         6. DRAIN<br/>         7. DRAIN<br/>         8. DRAIN</p>  | <p>STYLE 14:<br/>         PIN 1. N-SOURCE<br/>         2. N-GATE<br/>         3. P-SOURCE<br/>         4. P-GATE<br/>         5. P-DRAIN<br/>         6. P-DRAIN<br/>         7. N-DRAIN<br/>         8. N-DRAIN</p>   | <p>STYLE 15:<br/>         PIN 1. ANODE 1<br/>         2. ANODE 1<br/>         3. ANODE 1<br/>         4. ANODE 1<br/>         5. CATHODE, COMMON<br/>         6. CATHODE, COMMON<br/>         7. CATHODE, COMMON<br/>         8. CATHODE, COMMON</p>               | <p>STYLE 16:<br/>         PIN 1. EMITTER, DIE #1<br/>         2. BASE, DIE #1<br/>         3. EMITTER, DIE #2<br/>         4. BASE, DIE #2<br/>         5. COLLECTOR, DIE #2<br/>         6. COLLECTOR, DIE #2<br/>         7. COLLECTOR, DIE #1<br/>         8. COLLECTOR, DIE #1</p> |
| <p>STYLE 17:<br/>         PIN 1. VCC<br/>         2. V2OUT<br/>         3. V1OUT<br/>         4. TXE<br/>         5. RXE<br/>         6. VEE<br/>         7. GND<br/>         8. ACC</p>  | <p>STYLE 18:<br/>         PIN 1. ANODE<br/>         2. ANODE<br/>         3. SOURCE<br/>         4. GATE<br/>         5. DRAIN<br/>         6. DRAIN<br/>         7. CATHODE<br/>         8. CATHODE</p>   | <p>STYLE 19:<br/>         PIN 1. SOURCE 1<br/>         2. GATE 1<br/>         3. SOURCE 2<br/>         4. GATE 2<br/>         5. DRAIN 2<br/>         6. MIRROR 2<br/>         7. DRAIN 1<br/>         8. MIRROR 1</p>   | <p>STYLE 20:<br/>         PIN 1. SOURCE (N)<br/>         2. GATE (N)<br/>         3. SOURCE (P)<br/>         4. GATE (P)<br/>         5. DRAIN<br/>         6. DRAIN<br/>         7. DRAIN<br/>         8. DRAIN</p>   |
| <p>STYLE 21:<br/>         PIN 1. CATHODE 1<br/>         2. CATHODE 2<br/>         3. CATHODE 3<br/>         4. CATHODE 4<br/>         5. CATHODE 5<br/>         6. COMMON ANODE<br/>         7. COMMON ANODE<br/>         8. CATHODE 6</p>  | <p>STYLE 22:<br/>         PIN 1. I/O LINE 1<br/>         2. COMMON CATHODE/VCC<br/>         3. COMMON CATHODE/VCC<br/>         4. I/O LINE 3<br/>         5. COMMON ANODE/GND<br/>         6. I/O LINE 4<br/>         7. I/O LINE 5<br/>         8. COMMON ANODE/GND</p> | <p>STYLE 23:<br/>         PIN 1. LINE 1 IN<br/>         2. COMMON ANODE/GND<br/>         3. COMMON ANODE/GND<br/>         4. LINE 2 IN<br/>         5. LINE 2 OUT<br/>         6. COMMON ANODE/GND<br/>         7. COMMON ANODE/GND<br/>         8. LINE 1 OUT</p> | <p>STYLE 24:<br/>         PIN 1. BASE<br/>         2. EMITTER<br/>         3. COLLECTOR/ANODE<br/>         4. COLLECTOR/ANODE<br/>         5. CATHODE<br/>         6. CATHODE<br/>         7. COLLECTOR/ANODE<br/>         8. COLLECTOR/ANODE</p>                                      |
| <p>STYLE 25:<br/>         PIN 1. VIN<br/>         2. N/C<br/>         3. REXT<br/>         4. GND<br/>         5. IOUT<br/>         6. IOUT<br/>         7. IOUT<br/>         8. IOUT</p>   | <p>STYLE 26:<br/>         PIN 1. GND<br/>         2. dv/dt<br/>         3. ENABLE<br/>         4. ILIMIT<br/>         5. SOURCE<br/>         6. SOURCE<br/>         7. SOURCE<br/>         8. VCC</p>  | <p>STYLE 27:<br/>         PIN 1. ILIMIT<br/>         2. OVLO<br/>         3. UVLO<br/>         4. INPUT+<br/>         5. SOURCE<br/>         6. SOURCE<br/>         7. SOURCE<br/>         8. DRAIN</p>  | <p>STYLE 28:<br/>         PIN 1. SW_TO_GND<br/>         2. DASIC_OFF<br/>         3. DASIC_SW_DET<br/>         4. GND<br/>         5. V_MON<br/>         6. VBULK<br/>         7. VBULK<br/>         8. VIN</p>  |
| <p>STYLE 29:<br/>         PIN 1. BASE, DIE #1<br/>         2. EMITTER, #1<br/>         3. BASE, #2<br/>         4. EMITTER, #2<br/>         5. COLLECTOR, #2<br/>         6. COLLECTOR, #2<br/>         7. COLLECTOR, #1<br/>         8. COLLECTOR, #1</p>                        | <p>STYLE 30:<br/>         PIN 1. DRAIN 1<br/>         2. DRAIN 1<br/>         3. GATE 2<br/>         4. SOURCE 2<br/>         5. SOURCE 1/DRAIN 2<br/>         6. SOURCE 1/DRAIN 2<br/>         7. SOURCE 1/DRAIN 2<br/>         8. GATE 1</p>                           |  |  |

<b>DOCUMENT NUMBER:</b>	<b>98ASB42564B</b>	Electronic versions are uncontrolled except when accessed directly from the Document Repository. Printed versions are uncontrolled except when stamped "CONTROLLED COPY" in red.
<b>DESCRIPTION:</b>	<b>SOIC-8 NB</b>	<b>PAGE 2 OF 2</b>

**onsemi** and **ONSEMI** are trademarks of Semiconductor Components Industries, LLC dba **onsemi** or its subsidiaries in the United States and/or other countries. **onsemi** reserves the right to make changes without further notice to any products herein. **onsemi** makes no warranty, representation or guarantee regarding the suitability of its products for any particular purpose, nor does **onsemi** assume any liability arising out of the application or use of any product or circuit, and specifically disclaims any and all liability, including without limitation special, consequential or incidental damages. **onsemi** does not convey any license under its patent rights nor the rights of others.



**onsemi**, **Onsemi**, and other names, marks, and brands are registered and/or common law trademarks of Semiconductor Components Industries, LLC dba "**onsemi**" or its affiliates and/or subsidiaries in the United States and/or other countries. **onsemi** owns the rights to a number of patents, trademarks, copyrights, trade secrets, and other intellectual property. A listing of **onsemi**'s product/patent coverage may be accessed at [www.onsemi.com/site/pdf/Patent-Marking.pdf](http://www.onsemi.com/site/pdf/Patent-Marking.pdf). **onsemi** reserves the right to make changes at any time to any products or information herein, without notice. The information herein is provided "as-is" and **onsemi** makes no warranty, representation or guarantee regarding the accuracy of the information, product features, availability, functionality, or suitability of its products for any particular purpose, nor does **onsemi** assume any liability arising out of the application or use of any product or circuit, and specifically disclaims any and all liability, including without limitation special, consequential or incidental damages. Buyer is responsible for its products and applications using **onsemi** products, including compliance with all laws, regulations and safety requirements or standards, regardless of any support or applications information provided by **onsemi**. "Typical" parameters which may be provided in **onsemi** data sheets and/or specifications can and do vary in different applications and actual performance may vary over time. All operating parameters, including "Typicals" must be validated for each customer application by customer's technical experts. **onsemi** does not convey any license under any of its intellectual property rights nor the rights of others. **onsemi** products are not designed, intended, or authorized for use as a critical component in life support systems or any FDA Class 3 medical devices or medical devices with a same or similar classification in a foreign jurisdiction or any devices intended for implantation in the human body. Should Buyer purchase or use **onsemi** products for any such unintended or unauthorized application, Buyer shall indemnify and hold **onsemi** and its officers, employees, subsidiaries, affiliates, and distributors harmless against all claims, costs, damages, and expenses, and reasonable attorney fees arising out of, directly or indirectly, any claim of personal injury or death associated with such unintended or unauthorized use, even if such claim alleges that **onsemi** was negligent regarding the design or manufacture of the part. **onsemi** is an Equal Opportunity/Affirmative Action Employer. This literature is subject to all applicable copyright laws and is not for resale in any manner.

---

## ADDITIONAL INFORMATION

### TECHNICAL PUBLICATIONS:

Technical Library: [www.onsemi.com/design/resources/technical-documentation](http://www.onsemi.com/design/resources/technical-documentation)  
onsemi Website: [www.onsemi.com](http://www.onsemi.com)

### ONLINE SUPPORT: [www.onsemi.com/support](http://www.onsemi.com/support)

For additional information, please contact your local Sales Representative at [www.onsemi.com/support/sales](http://www.onsemi.com/support/sales)