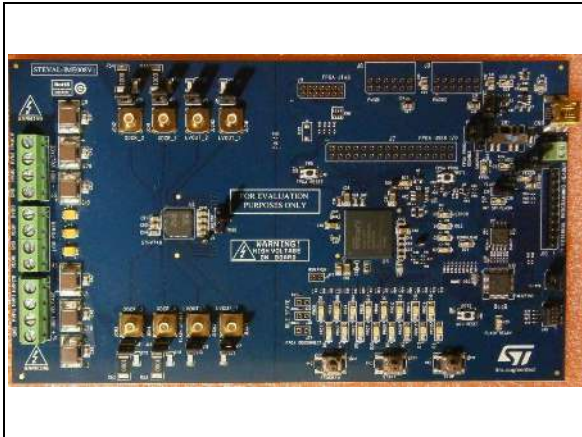

**STHV749 Ultrasound Pulser IC evaluation board**

Data brief

**Description**

The STEVAL-IME008V1 is a product evaluation board designed around the STHV749 4-channel 7-level high voltage pulser, a state-of-the-art device designed for ultrasound imaging applications.

The output waveforms can be displayed directly on an oscilloscope by connecting the scope probe to the relative BNCs. 16 preset waveforms are available to test the HV pulser under varying conditions.

**Features**

- 4-channel outputs: high voltage and low voltage BNC connectors
- Load simulator using signal equivalent circuits
- Possibility to set up own load simulator
- 16 preset waveforms
- USB connector to connect STM32 with PC and supply power to it
- 4 MB serial Flash memory to host FPGA code and waveforms
- Memory expansion connector to add external serial Flash
- Connectors to supply high voltage and low voltage to the STHV749 output stage
- LEDs to monitor the power management stage
- Human machine interface to select, start and stop the generation of the preset waveforms
- 25 LEDs to monitor board behavior
- RoHS compliant

# 1 Schematic diagrams

Figure 1. STEVAL-IME008V1 circuit schematic (1 of 16)

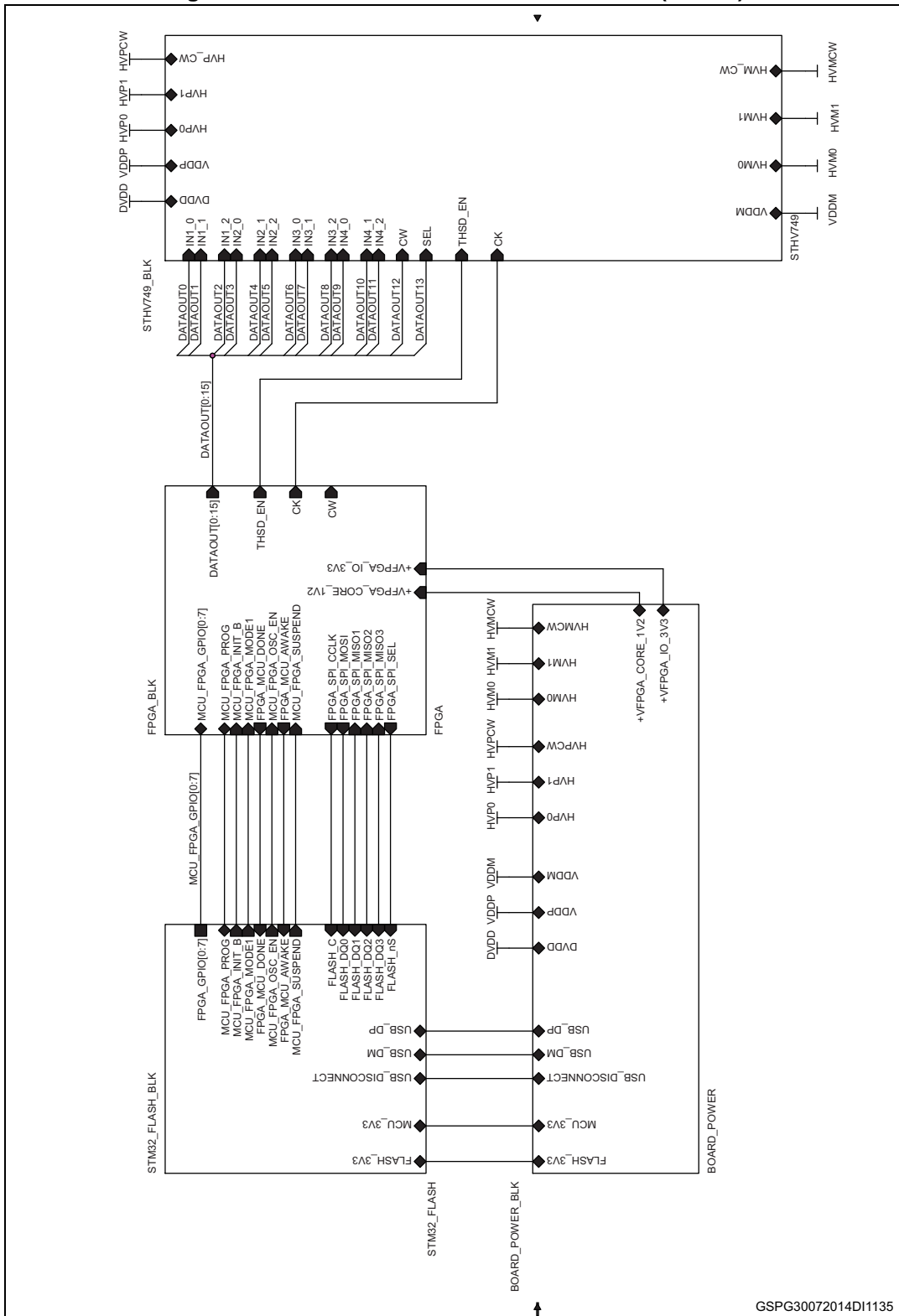

GSPG30072014D11135



Figure 2. STEVAL-IME008V1 circuit schematic (2 of 16)

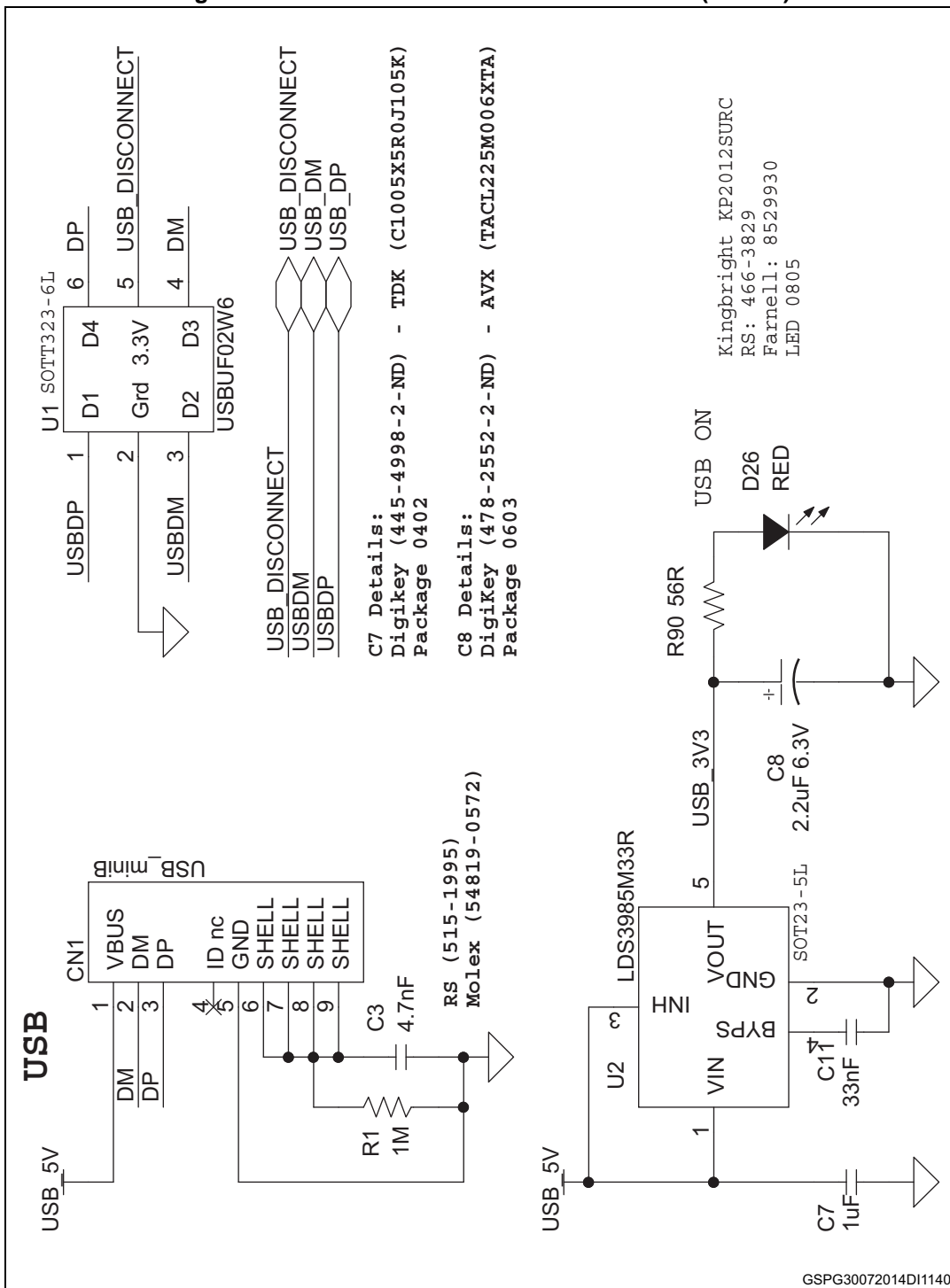
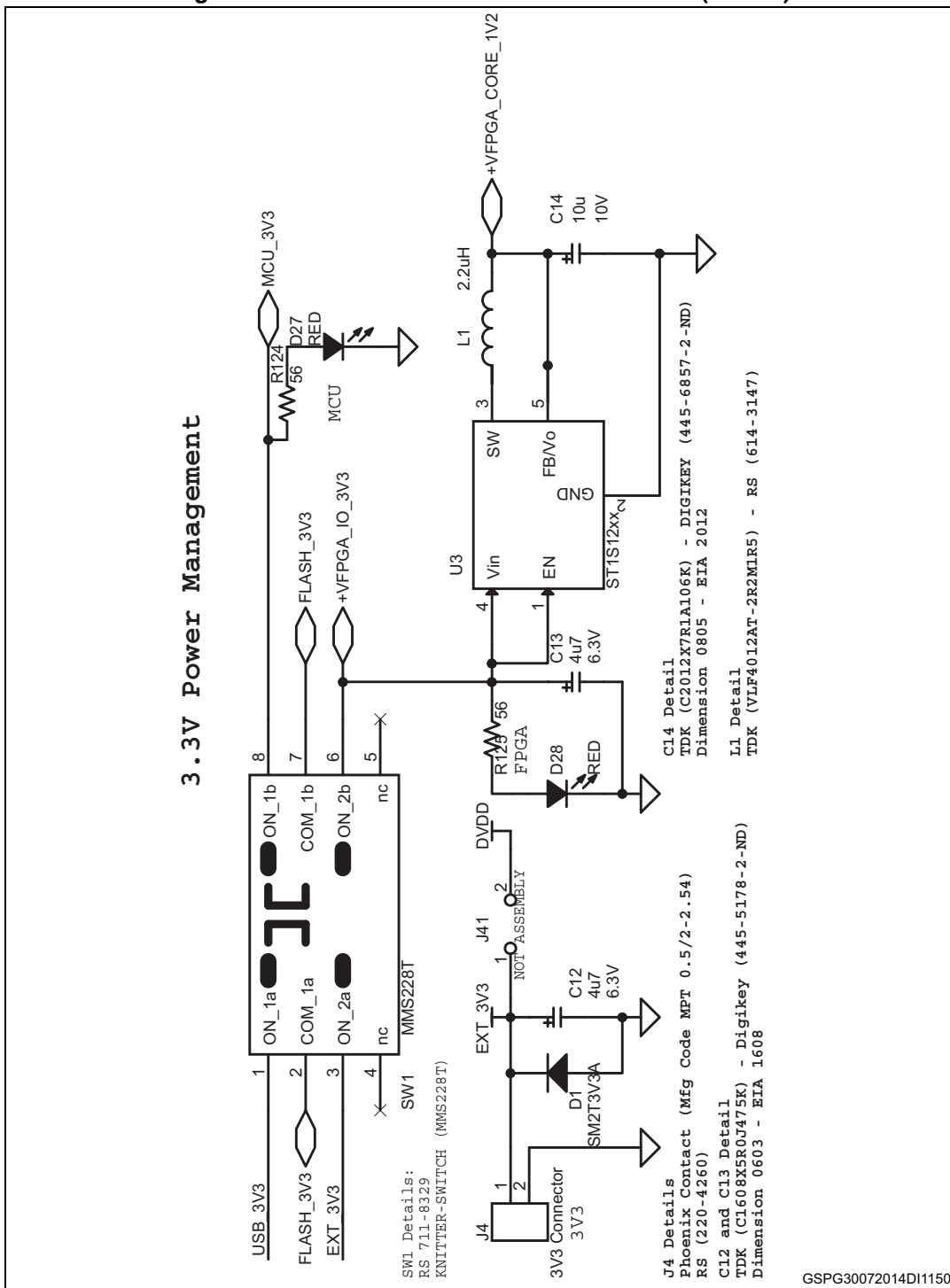

Figure 3. STEVAL-IME008V1 circuit schematic (3 of 16)



GSPG30072014DI1150



Figure 4. STEVAL-IME008V1 circuit schematic (4 of 16)

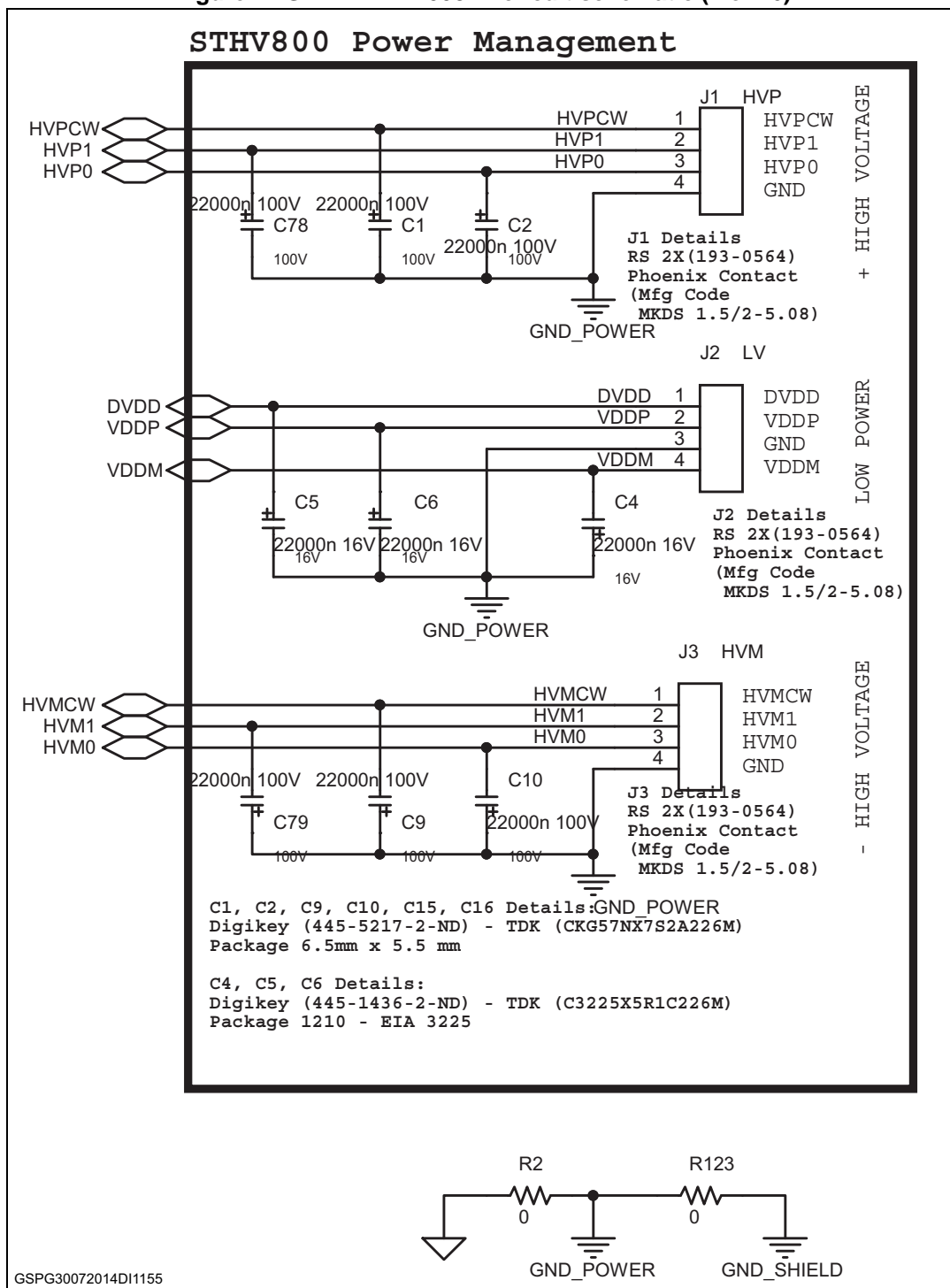

Figure 5. STEVAL-IME008V1 circuit schematic (5 of 16)

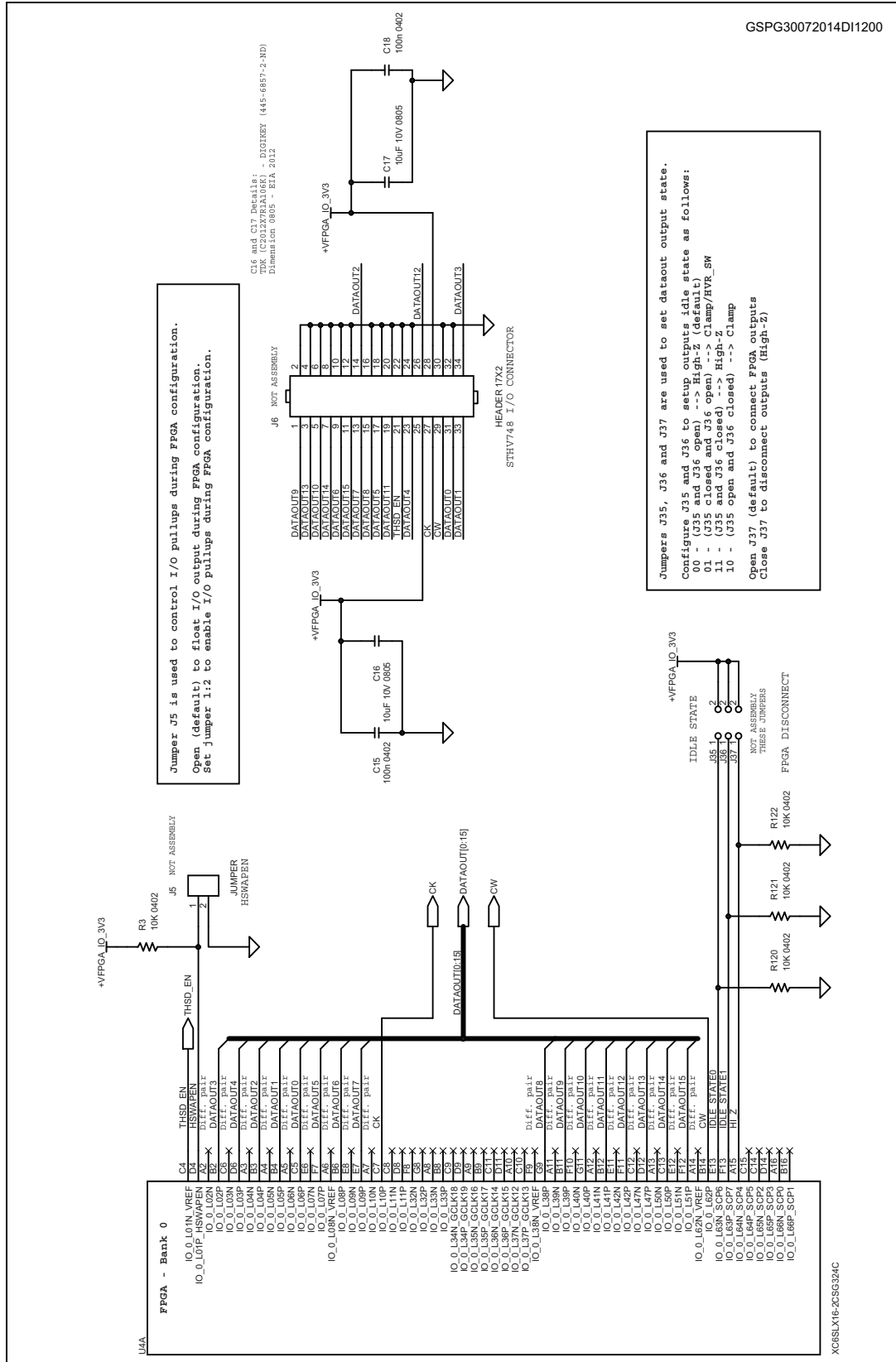

Figure 6. STEVAL-IME008V1 circuit schematic (6 of 16)

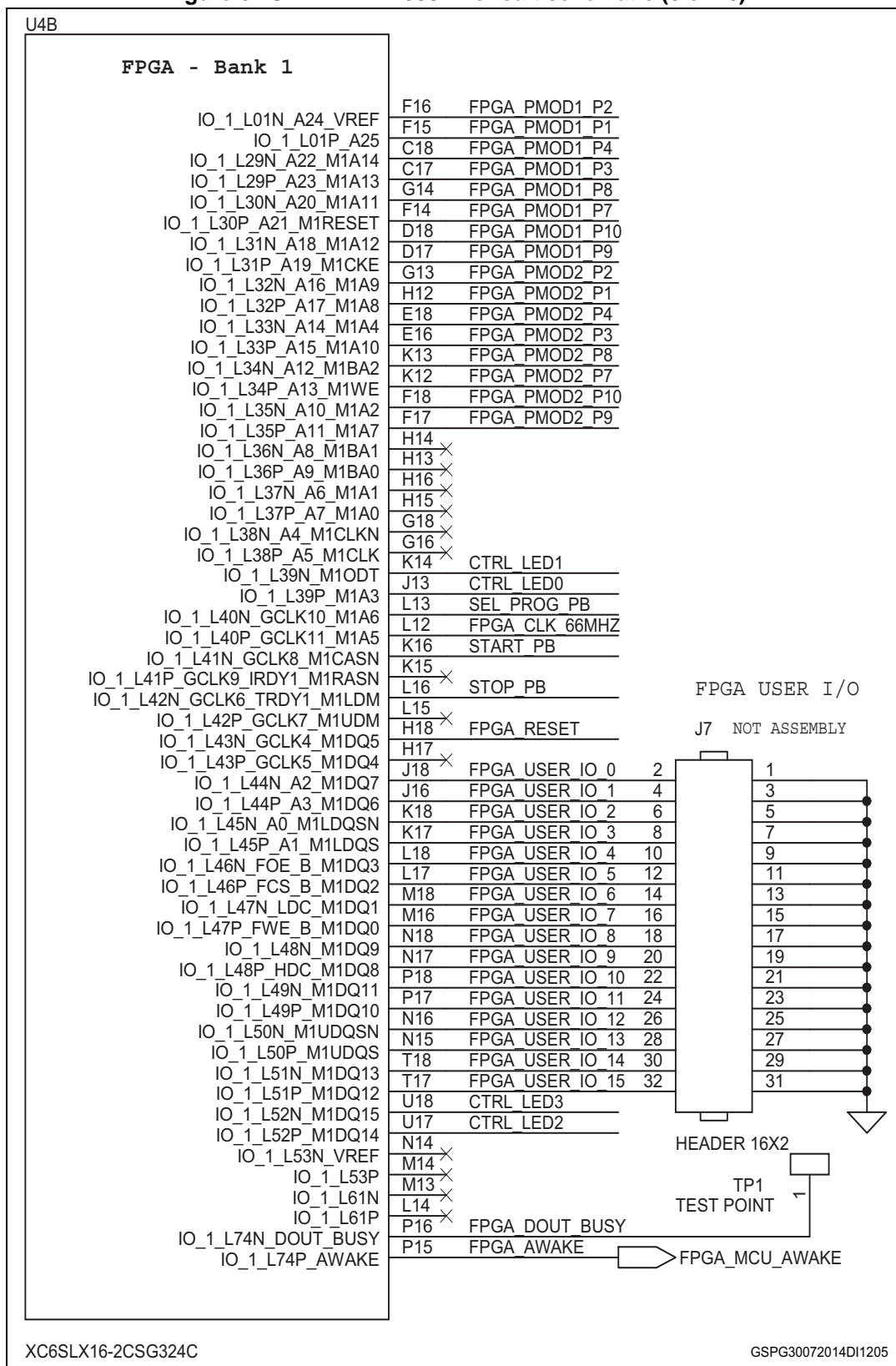

Figure 7. STEVAL-IME008V1 circuit schematic (7 of 16)

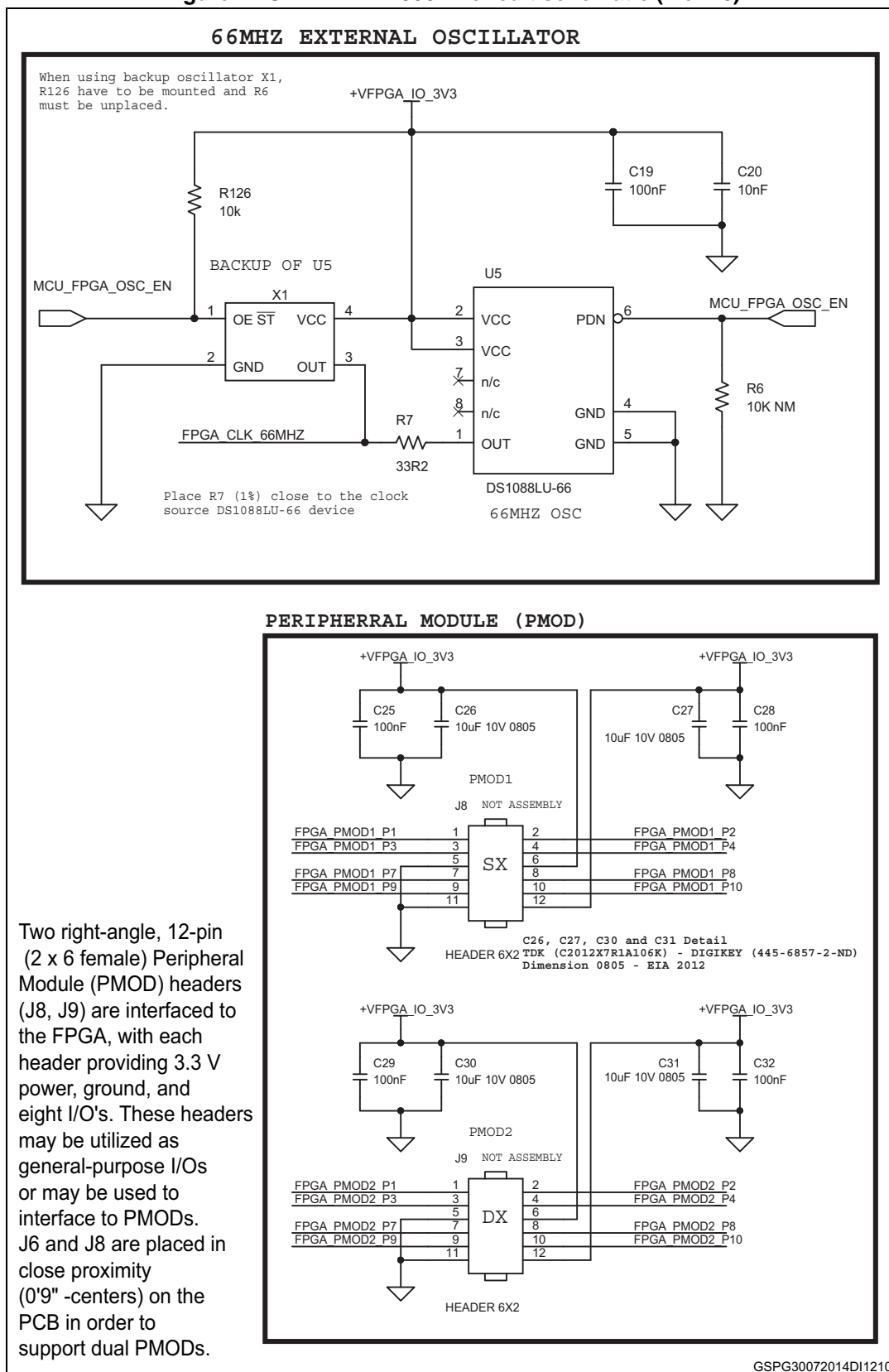



Figure 8. STEVAL-IME008V1 circuit schematic (8 of 16)

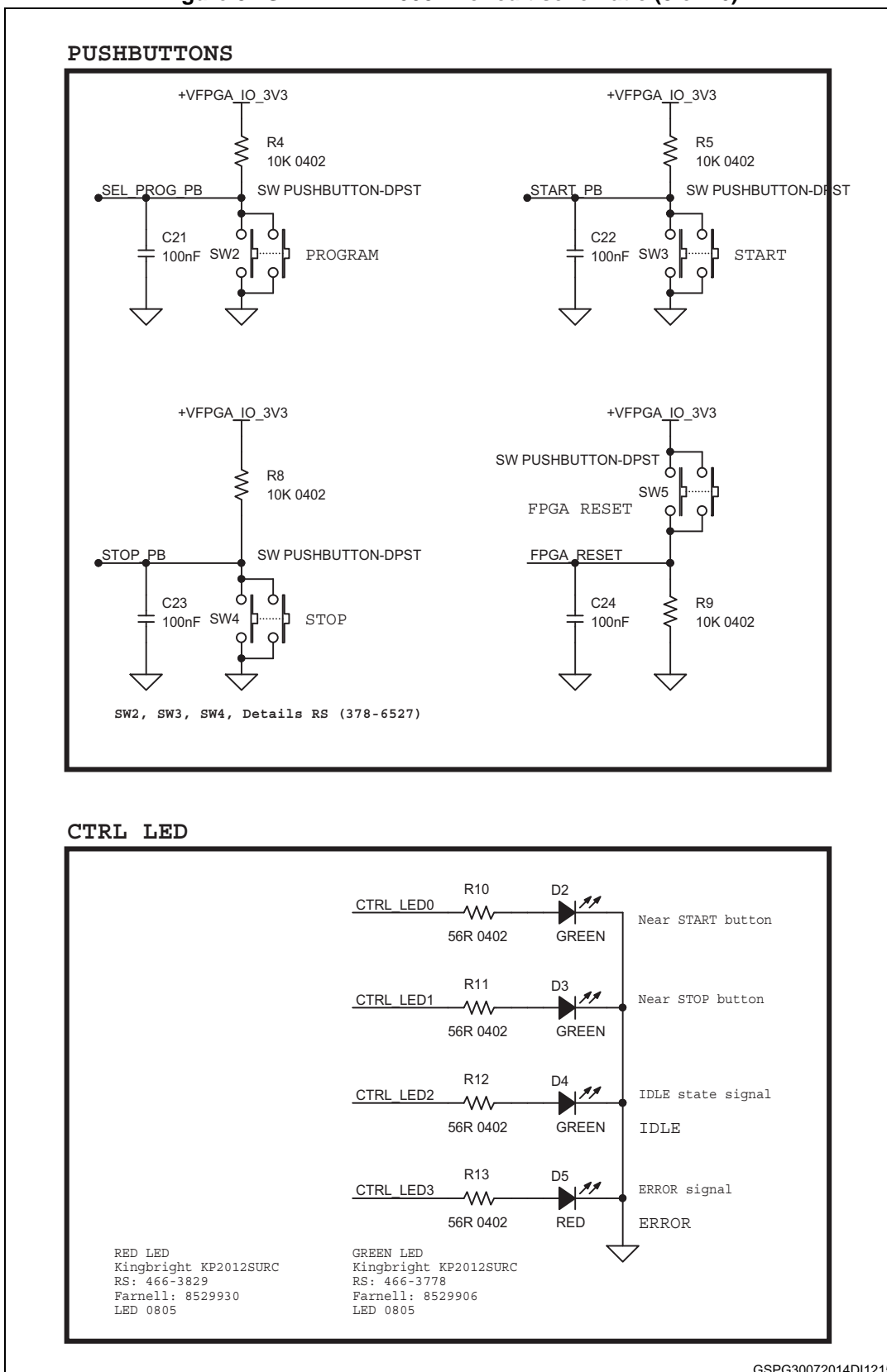

Figure 9. STEVAL-IME008V1 circuit schematic (9 of 16)

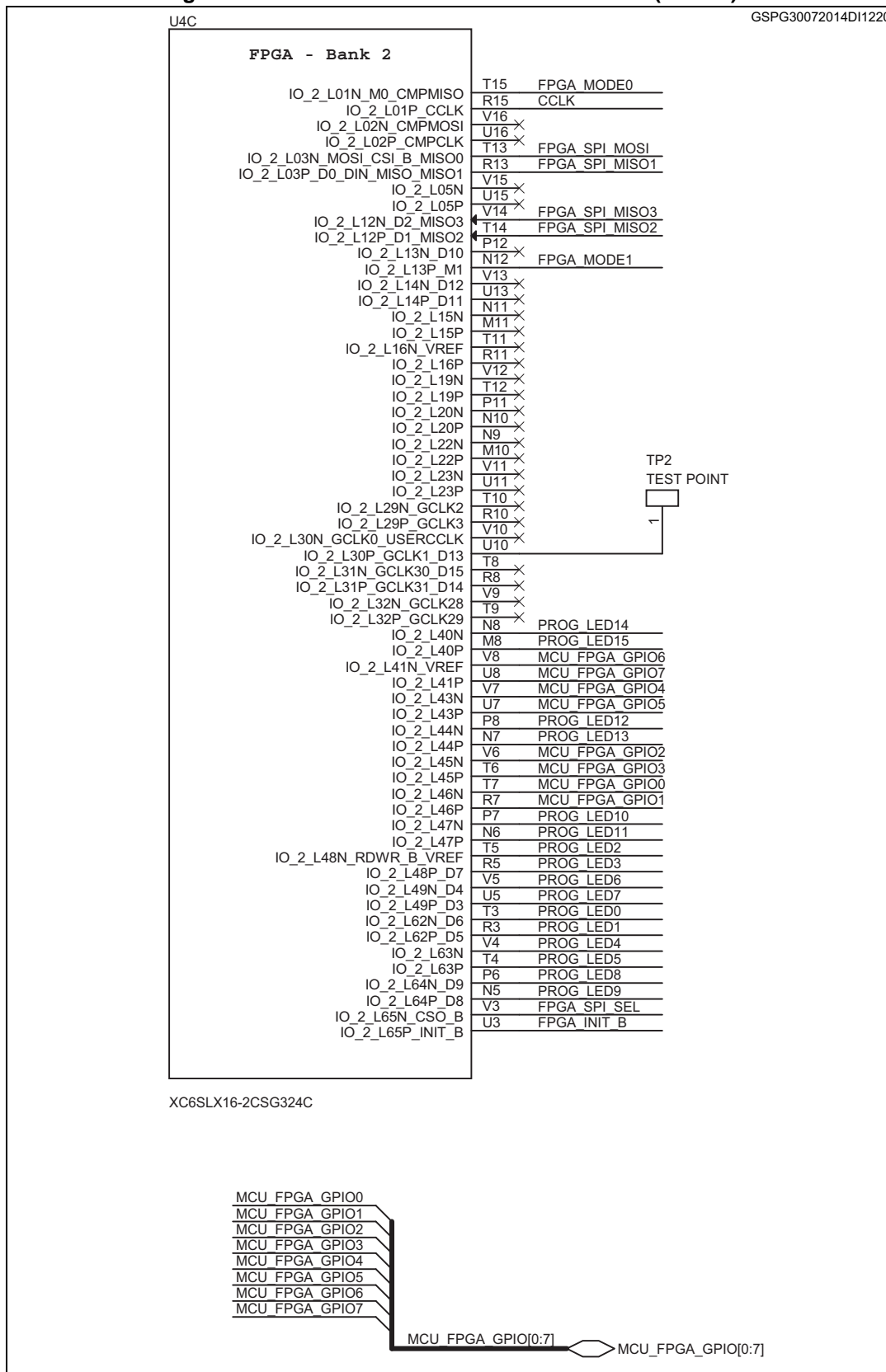

Figure 10. STEVAL-IME008V1 circuit schematic (10 of 16)

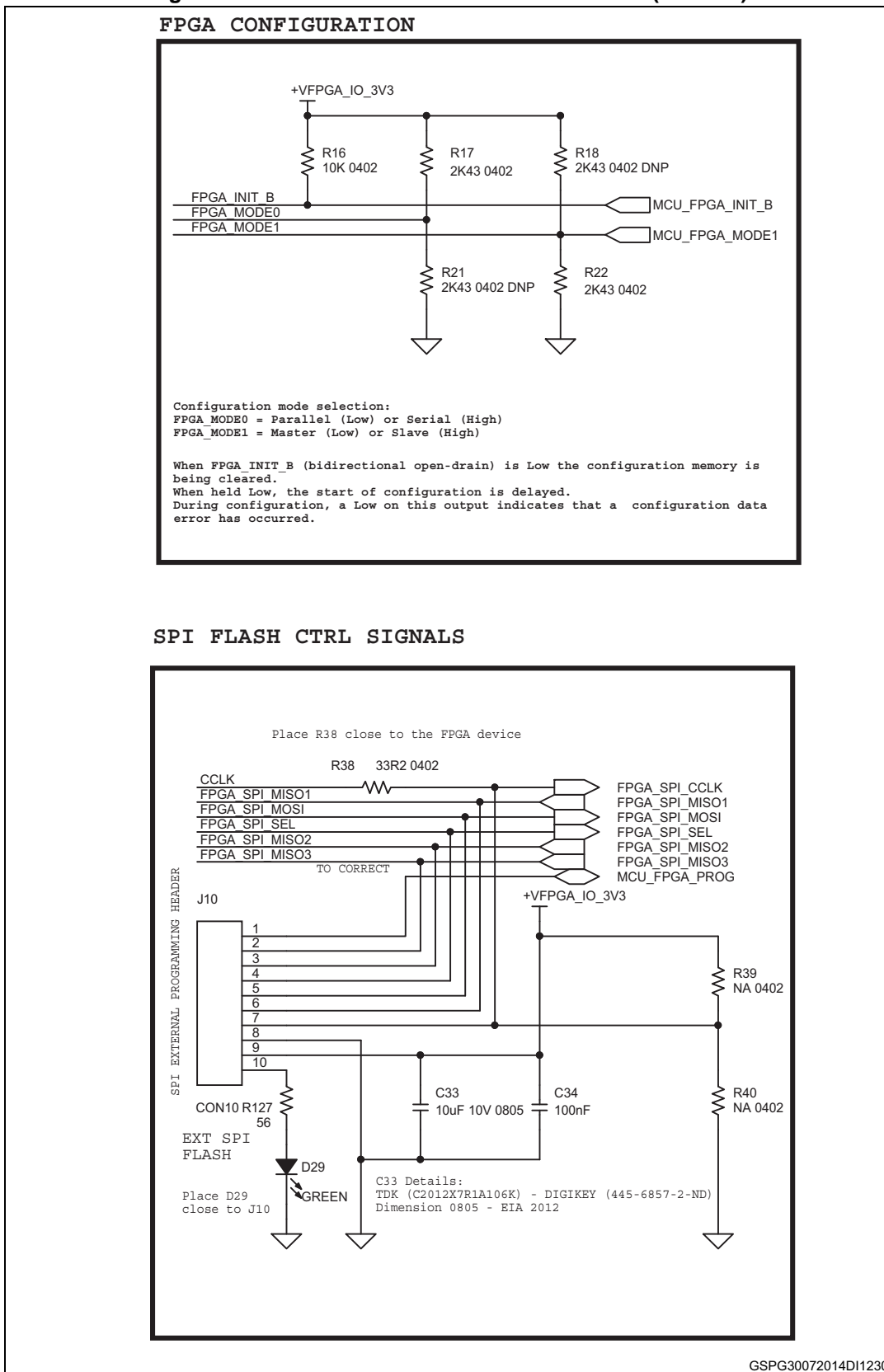

Figure 11. STEVAL-IME008V1 circuit schematic (11 of 16)

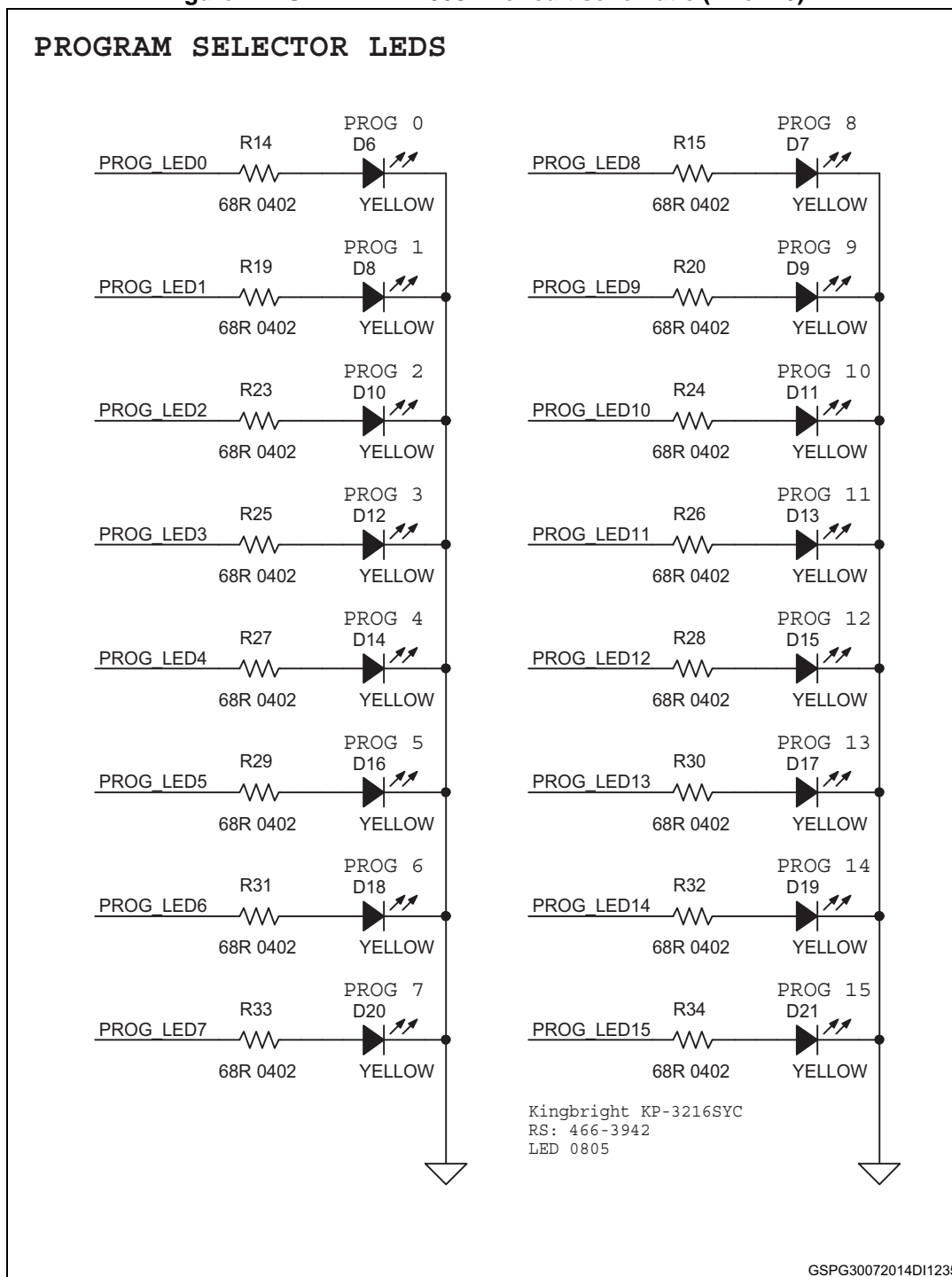
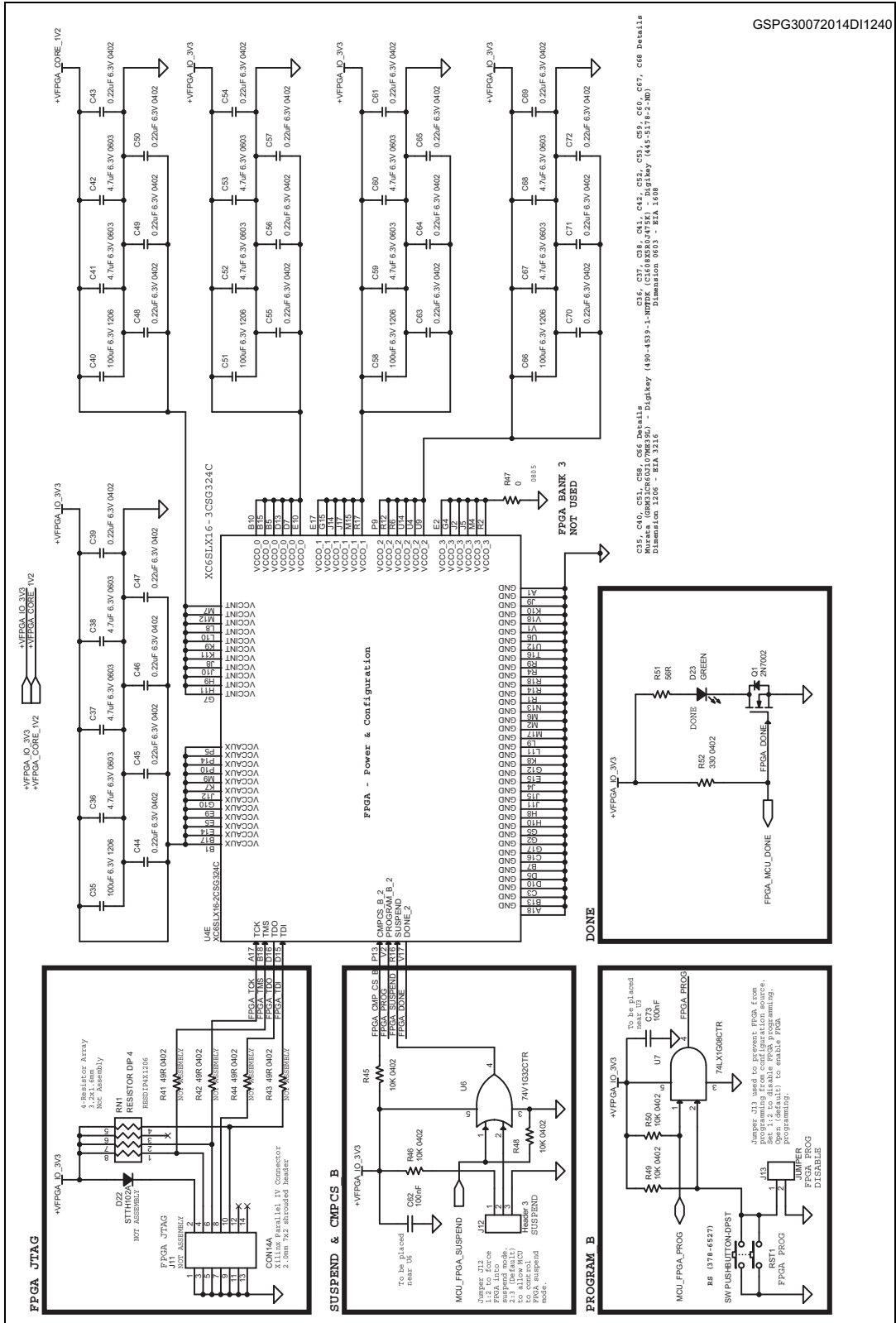

Figure 12. STEVAL-IME008V1 circuit schematic (12 of 16)



GSPG30072014D11240

C52, C55, C56, C57, C58, C59, C60, C61, C62, C63, C64, C65, C66, C67, C68, C69, C70, C71, C72, C73, C74, C75, C76, C77, C78, C79, C80, C81, C82, C83, C84, C85, C86, C87, C88, C89, C90, C91, C92, C93, C94, C95, C96, C97, C98, C99, C100, C101, C102, C103, C104, C105, C106, C107, C108, C109, C110, C111, C112, C113, C114, C115, C116, C117, C118, C119, C120, C121, C122, C123, C124, C125, C126, C127, C128, C129, C130, C131, C132, C133, C134, C135, C136, C137, C138, C139, C140, C141, C142, C143, C144, C145, C146, C147, C148, C149, C150, C151, C152, C153, C154, C155, C156, C157, C158, C159, C160, C161, C162, C163, C164, C165, C166, C167, C168, C169, C170, C171, C172, C173, C174, C175, C176, C177, C178, C179, C180, C181, C182, C183, C184, C185, C186, C187, C188, C189, C190, C191, C192, C193, C194, C195, C196, C197, C198, C199, C200, C201, C202, C203, C204, C205, C206, C207, C208, C209, C210, C211, C212, C213, C214, C215, C216, C217, C218, C219, C220, C221, C222, C223, C224, C225, C226, C227, C228, C229, C230, C231, C232, C233, C234, C235, C236, C237, C238, C239, C240, C241, C242, C243, C244, C245, C246, C247, C248, C249, C250, C251, C252, C253, C254, C255, C256, C257, C258, C259, C260, C261, C262, C263, C264, C265, C266, C267, C268, C269, C270, C271, C272, C273, C274, C275, C276, C277, C278, C279, C280, C281, C282, C283, C284, C285, C286, C287, C288, C289, C290, C291, C292, C293, C294, C295, C296, C297, C298, C299, C300, C301, C302, C303, C304, C305, C306, C307, C308, C309, C310, C311, C312, C313, C314, C315, C316, C317, C318, C319, C320, C321, C322, C323, C324, C325, C326, C327, C328, C329, C330, C331, C332, C333, C334, C335, C336, C337, C338, C339, C340, C341, C342, C343, C344, C345, C346, C347, C348, C349, C350, C351, C352, C353, C354, C355, C356, C357, C358, C359, C360, C361, C362, C363, C364, C365, C366, C367, C368, C369, C370, C371, C372, C373, C374, C375, C376, C377, C378, C379, C380, C381, C382, C383, C384, C385, C386, C387, C388, C389, C390, C391, C392, C393, C394, C395, C396, C397, C398, C399, C400, C401, C402, C403, C404, C405, C406, C407, C408, C409, C410, C411, C412, C413, C414, C415, C416, C417, C418, C419, C420, C421, C422, C423, C424, C425, C426, C427, C428, C429, C430, C431, C432, C433, C434, C435, C436, C437, C438, C439, C440, C441, C442, C443, C444, C445, C446, C447, C448, C449, C450, C451, C452, C453, C454, C455, C456, C457, C458, C459, C460, C461, C462, C463, C464, C465, C466, C467, C468, C469, C470, C471, C472, C473, C474, C475, C476, C477, C478, C479, C480, C481, C482, C483, C484, C485, C486, C487, C488, C489, C490, C491, C492, C493, C494, C495, C496, C497, C498, C499, C500, C501, C502, C503, C504, C505, C506, C507, C508, C509, C510, C511, C512, C513, C514, C515, C516, C517, C518, C519, C520, C521, C522, C523, C524, C525, C526, C527, C528, C529, C530, C531, C532, C533, C534, C535, C536, C537, C538, C539, C540, C541, C542, C543, C544, C545, C546, C547, C548, C549, C550, C551, C552, C553, C554, C555, C556, C557, C558, C559, C560, C561, C562, C563, C564, C565, C566, C567, C568, C569, C570, C571, C572, C573, C574, C575, C576, C577, C578, C579, C580, C581, C582, C583, C584, C585, C586, C587, C588, C589, C590, C591, C592, C593, C594, C595, C596, C597, C598, C599, C600, C601, C602, C603, C604, C605, C606, C607, C608, C609, C610, C611, C612, C613, C614, C615, C616, C617, C618, C619, C620, C621, C622, C623, C624, C625, C626, C627, C628, C629, C630, C631, C632, C633, C634, C635, C636, C637, C638, C639, C640, C641, C642, C643, C644, C645, C646, C647, C648, C649, C650, C651, C652, C653, C654, C655, C656, C657, C658, C659, C660, C661, C662, C663, C664, C665, C666, C667, C668, C669, C670, C671, C672, C673, C674, C675, C676, C677, C678, C679, C680, C681, C682, C683, C684, C685, C686, C687, C688, C689, C690, C691, C692, C693, C694, C695, C696, C697, C698, C699, C700, C701, C702, C703, C704, C705, C706, C707, C708, C709, C710, C711, C712, C713, C714, C715, C716, C717, C718, C719, C720, C721, C722, C723, C724, C725, C726, C727, C728, C729, C730, C731, C732, C733, C734, C735, C736, C737, C738, C739, C740, C741, C742, C743, C744, C745, C746, C747, C748, C749, C750, C751, C752, C753, C754, C755, C756, C757, C758, C759, C760, C761, C762, C763, C764, C765, C766, C767, C768, C769, C770, C771, C772, C773, C774, C775, C776, C777, C778, C779, C780, C781, C782, C783, C784, C785, C786, C787, C788, C789, C790, C791, C792, C793, C794, C795, C796, C797, C798, C799, C800, C801, C802, C803, C804, C805, C806, C807, C808, C809, C810, C811, C812, C813, C814, C815, C816, C817, C818, C819, C820, C821, C822, C823, C824, C825, C826, C827, C828, C829, C830, C831, C832, C833, C834, C835, C836, C837, C838, C839, C840, C841, C842, C843, C844, C845, C846, C847, C848, C849, C850, C851, C852, C853, C854, C855, C856, C857, C858, C859, C860, C861, C862, C863, C864, C865, C866, C867, C868, C869, C870, C871, C872, C873, C874, C875, C876, C877, C878, C879, C880, C881, C882, C883, C884, C885, C886, C887, C888, C889, C890, C891, C892, C893, C894, C895, C896, C897, C898, C899, C900, C901, C902, C903, C904, C905, C906, C907, C908, C909, C910, C911, C912, C913, C914, C915, C916, C917, C918, C919, C920, C921, C922, C923, C924, C925, C926, C927, C928, C929, C930, C931, C932, C933, C934, C935, C936, C937, C938, C939, C940, C941, C942, C943, C944, C945, C946, C947, C948, C949, C950, C951, C952, C953, C954, C955, C956, C957, C958, C959, C960, C961, C962, C963, C964, C965, C966, C967, C968, C969, C970, C971, C972, C973, C974, C975, C976, C977, C978, C979, C980, C981, C982, C983, C984, C985, C986, C987, C988, C989, C990, C991, C992, C993, C994, C995, C996, C997, C998, C999, C1000, C1001, C1002, C1003, C1004, C1005, C1006, C1007, C1008, C1009, C1010, C1011, C1012, C1013, C1014, C1015, C1016, C1017, C1018, C1019, C1020, C1021, C1022, C1023, C1024, C1025, C1026, C1027, C1028, C1029, C1030, C1031, C1032, C1033, C1034, C1035, C1036, C1037, C1038, C1039, C1040, C1041, C1042, C1043, C1044, C1045, C1046, C1047, C1048, C1049, C1050, C1051, C1052, C1053, C1054, C1055, C1056, C1057, C1058, C1059, C1060, C1061, C1062, C1063, C1064, C1065, C1066, C1067, C1068, C1069, C1070, C1071, C1072, C1073, C1074, C1075, C1076, C1077, C1078, C1079, C1080, C1081, C1082, C1083, C1084, C1085, C1086, C1087, C1088, C1089, C1090, C1091, C1092, C1093, C1094, C1095, C1096, C1097, C1098, C1099, C1100, C1101, C1102, C1103, C1104, C1105, C1106, C1107, C1108, C1109, C1110, C1111, C1112, C1113, C1114, C1115, C1116, C1117, C1118, C1119, C1120, C1121, C1122, C1123, C1124, C1125, C1126, C1127, C1128, C1129, C1130, C1131, C1132, C1133, C1134, C1135, C1136, C1137, C1138, C1139, C1140, C1141, C1142, C1143, C1144, C1145, C1146, C1147, C1148, C1149, C1150, C1151, C1152, C1153, C1154, C1155, C1156, C1157, C1158, C1159, C1160, C1161, C1162, C1163, C1164, C1165, C1166, C1167, C1168, C1169, C1170, C1171, C1172, C1173, C1174, C1175, C1176, C1177, C1178, C1179, C1180, C1181, C1182, C1183, C1184, C1185, C1186, C1187, C1188, C1189, C1190, C1191, C1192, C1193, C1194, C1195, C1196, C1197, C1198, C1199, C1200, C1201, C1202, C1203, C1204, C1205, C1206, C1207, C1208, C1209, C1210, C1211, C1212, C1213, C1214, C1215, C1216, C1217, C1218, C1219, C1220, C1221, C1222, C1223, C1224, C1225, C1226, C1227, C1228, C1229, C1230, C1231, C1232, C1233, C1234, C1235, C1236, C1237, C1238, C1239, C1240, C1241, C1242, C1243, C1244, C1245, C1246, C1247, C1248, C1249, C1250, C1251, C1252, C1253, C1254, C1255, C1256, C1257, C1258, C1259, C1260, C1261, C1262, C1263, C1264, C1265, C1266, C1267, C1268, C1269, C1270, C1271, C1272, C1273, C1274, C1275, C1276, C1277, C1278, C1279, C1280, C1281, C1282, C1283, C1284, C1285, C1286, C1287, C1288, C1289, C1290, C1291, C1292, C1293, C1294, C1295, C1296, C1297, C1298, C1299, C1300, C1301, C1302, C1303, C1304, C1305, C1306, C1307, C1308, C1309, C1310, C1311, C1312, C1313, C1314, C1315, C1316, C1317, C1318, C1319, C1320, C1321, C1322, C1323, C1324, C1325, C1326, C1327, C1328, C1329, C1330, C1331, C1332, C1333, C1334, C1335, C1336, C1337, C1338, C1339, C1340, C1341, C1342, C1343, C1344, C1345, C1346, C1347, C1348, C1349, C1350, C1351, C1352, C1353, C1354, C1355, C1356, C1357, C1358, C1359, C1360, C1361, C1362, C1363, C1364, C1365, C1366, C1367, C1368, C1369, C1370, C1371, C1372, C1373, C1374, C1375, C1376, C1377, C1378, C1379, C1380, C1381, C1382, C1383, C1384, C1385, C1386, C1387, C1388, C1389, C1390, C1391, C1392, C1393, C1394, C1395, C1396, C1397, C1398, C1399, C1400, C1401, C1402, C1403, C1404, C1405, C1406, C1407, C1408, C1409, C1410, C1411, C1412, C1413, C1414, C1415, C1416, C1417, C1418, C1419, C1420, C1421, C1422, C1423, C1424, C1425, C1426, C1427, C1428, C1429, C1430, C1431, C1432, C1433, C1434, C1435, C1436, C1437, C1438, C1439, C1440, C1441, C1442, C1443, C1444, C1445, C1446, C1447, C1448, C1449, C1450, C1451, C1452, C1453, C1454, C1455, C1456, C1457, C1458, C1459, C1460, C1461, C1462, C1463, C1464, C1465, C1466, C1467, C1468, C1469, C1470, C1471, C1472, C1473, C1474, C1475, C1476, C1477, C1478, C1479, C1480, C1481, C1482, C1483, C1484, C1485, C1486, C1487, C1488, C1489, C1490, C1491, C1492, C1493, C1494, C1495, C1496, C1497, C1498, C1499, C1500, C1501, C1502, C1503, C1504, C1505, C1506, C1507, C1508, C1509, C1510, C1511, C1512, C1513, C1514, C1515, C1516, C1517, C1518, C1519, C1520, C1521, C1522, C1523, C1524, C1525, C1526, C1527, C1528, C1529, C1530, C1531, C1532, C1533, C1534, C1535, C1536, C1537, C1538, C1539, C1540, C1541, C1542, C1543, C1544, C1545, C1546, C1547, C1548, C1549, C1550, C1551, C1552, C1553, C1554, C1555, C1556, C1557, C1558, C1559, C1560, C1561, C1562, C1563, C1564, C1565, C1566, C1567, C1568, C1569, C1570, C1571, C1572, C1573, C1574, C1575, C1576, C1577, C1578, C1579, C1580, C1581, C1582, C1583, C1584, C1585, C1586, C1587, C1588, C1589, C1590, C1591, C1592, C1593, C1594, C1595, C1596, C1597, C1598, C1599, C1600, C1601, C1602, C1603, C1604, C1605, C1606, C1607, C1608, C1609, C1610, C1611, C1612, C1613, C1614, C1615, C1616, C1617, C1618, C1619, C1620, C1621, C1622, C1623, C1624, C1625, C1626, C1627, C1628, C1629, C1630, C1631, C1632, C1633, C1634, C1635, C1636, C1637, C1638, C1639, C1640, C1641, C1642, C1643, C1644, C1645, C1646, C1647, C1648, C1649, C1650, C1651, C1652, C1653, C1654, C1655, C1656, C1657, C1658, C1659, C1660, C1661, C1662, C1663, C1664, C1665, C1666, C1667, C1668, C1669, C1670, C1671, C1672, C1673, C1674, C1675, C1676, C1677, C1678, C1679, C1680, C1681, C1682, C1683, C1684, C1685, C1686, C1687, C1688, C1689, C1690, C1691, C1692, C1693, C1694, C1695, C1696, C1697, C1698, C1699, C1700, C1701, C1702, C1703, C1704, C1705, C1706, C1707, C1708, C1709, C1710, C1711, C1712, C1713, C1714, C1715, C1716, C1717, C1718, C1719, C1720, C1721, C1722, C1723, C1724, C1725, C1726, C1727, C1728, C1729, C1730, C1731, C1732, C1733, C1734, C1735, C1736, C1737, C1738, C1739, C1740, C1741, C1742, C1743, C1744, C1745, C1746, C1747, C1748, C1749, C1750, C1751, C1752, C1753, C1754, C1755, C1756, C1757, C1758, C1759, C1760, C1761, C1762, C1763, C1764, C1765, C1766, C1767, C1768, C1769, C1770, C1771, C1772, C1773, C1774, C1775, C1776, C1777, C1778, C1779, C1780, C1781, C1782, C1783, C1784, C1785, C1786, C1787, C1788, C1789, C1790, C1791, C1792, C1793, C1794, C1795, C1796, C1797, C1798, C1799, C1800, C1801, C1802, C1803, C1804, C1805, C1806, C1807, C1808, C1809, C1810, C1811, C1812, C1813, C1814, C1815, C1816, C1817, C1818, C1819, C1820, C1821, C1822, C1823, C1824, C1825, C1826, C1827, C1828, C1829, C1830, C1831, C1832, C1833, C1834, C1835, C1836, C1837, C1838, C1839, C1840, C1841, C1842, C1843, C1844, C1845, C1846, C1847, C1848, C1849, C1850, C1851, C1852, C1853, C1854, C1855, C1856, C1857, C1858, C1859, C1860, C1861, C1862, C1863, C1864, C1865, C1866, C1867, C1868, C1869, C1870, C1871, C1872, C1873, C1874, C1875, C1876, C1877, C1878, C1879, C1880, C1881, C1882, C1883, C1884, C1885, C1886, C1887, C1888, C1889, C1890, C1891, C1892, C1893, C1894, C1895, C1896, C1897, C1898, C1899, C1900, C1901, C1902, C1903, C1904, C1905, C1906, C1907, C1908, C1909, C1910, C1911, C1912, C1913, C1914, C1915, C1916, C1917, C1918, C1919, C1920, C1921, C1922, C1923, C1924, C1925, C1926, C1927, C1928, C1929, C1930, C1931, C1932, C1933, C1934, C1935, C1936, C1937, C1938, C1939, C1940, C1941, C1942, C1943, C1944, C1945, C1946, C1947, C1948, C1949, C1950, C1951, C1952, C1953, C1954, C1955, C1956, C1957, C1958, C1959, C1960, C1961, C1962, C1963, C1964, C1965, C1966, C1967, C1968, C1969, C1970, C1971, C1972, C1973, C1974, C1975, C1976, C1977, C1978, C1979, C1980, C1981, C1982, C1983, C1984, C1985, C1986, C1987, C1988, C1989, C1990, C1991, C1992, C1993, C1994, C1995, C1996, C1997, C1998, C1999, C2000, C2001, C2002, C2003, C2004, C2005, C2006, C2007, C2008, C2009, C2010, C2011, C2012, C2013, C2014, C2015, C2016, C2017, C2018, C2019, C2020, C2021, C2022, C2023, C2024, C2025, C2026, C2027, C2028, C2029, C2030, C2031, C2032, C2033, C2034, C2035, C2036, C2037, C2038, C2039, C2040, C2041, C2042, C2043, C2044, C2045, C2046, C2047, C2048, C2049, C2050, C2051, C2052, C2053, C2054, C2055, C2056, C2057, C2058, C2059, C2060, C2061, C2062, C2063, C2064, C2065, C2066, C2067, C2068, C2069, C2070, C2071, C2072, C2073, C2074, C2075, C2076, C2077, C2078, C2079, C2080, C2081, C2082, C2083, C2084, C2085, C2086, C2087, C2088, C2089, C2090, C2091, C2092, C2093, C2094, C2095, C2096, C2097, C2098, C2099, C2100, C2101, C2102, C2103, C2104, C2105, C2106, C2107, C2108, C2109, C2110, C2111, C2112, C2113, C2114, C2115, C2116, C2117, C2118, C2119, C2120, C2121, C2122, C2123, C2124, C2125, C2126, C2127, C2128, C2129, C2130, C2131, C2132, C2133, C2134, C2135, C2136, C2137, C2138, C2139, C2140, C2141, C214



Figure 14. STEVAL-IME008V1 circuit schematic (14 of 16)

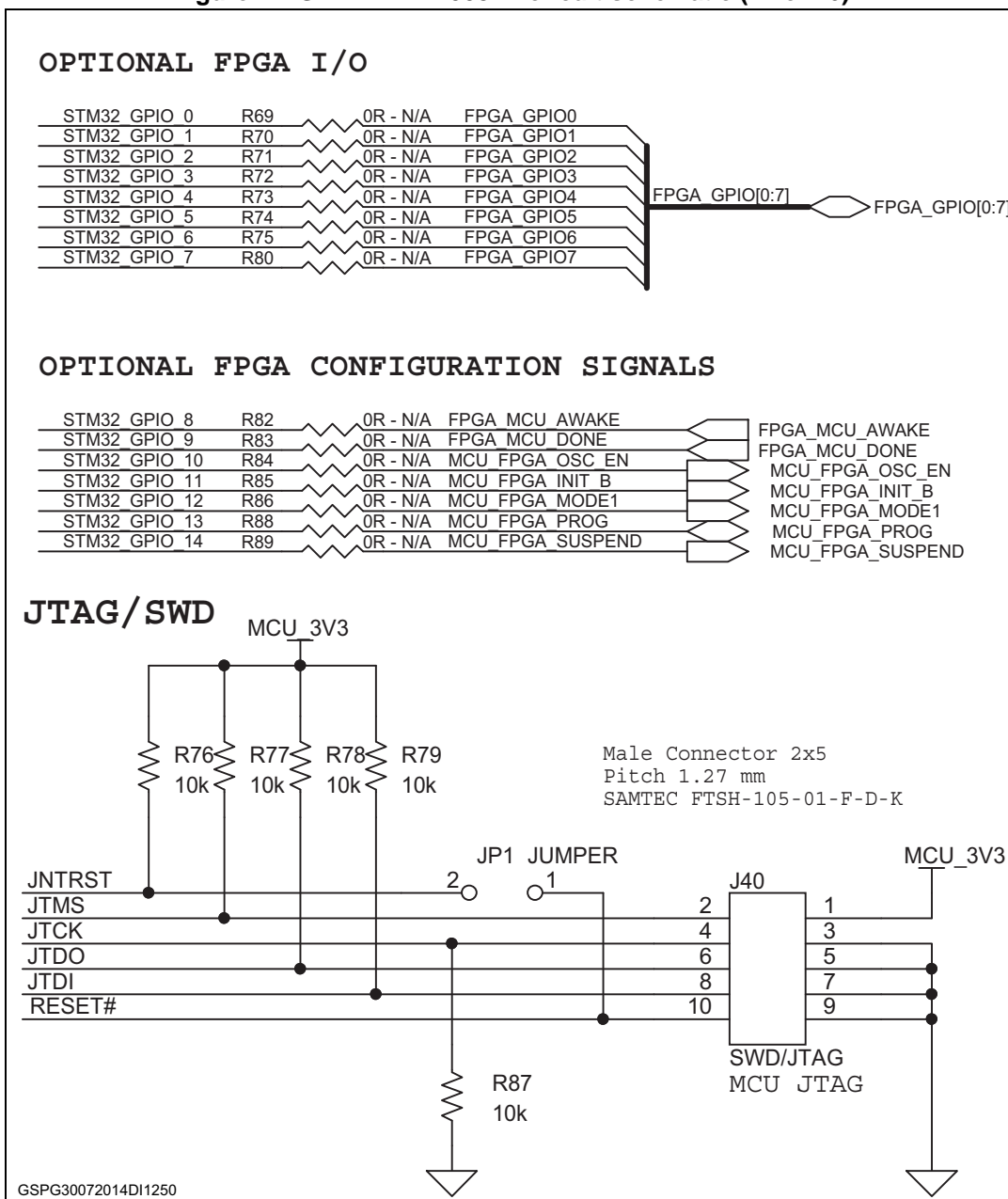

Figure 15. STEVAL-IME008V1 circuit schematic (15 of 16)

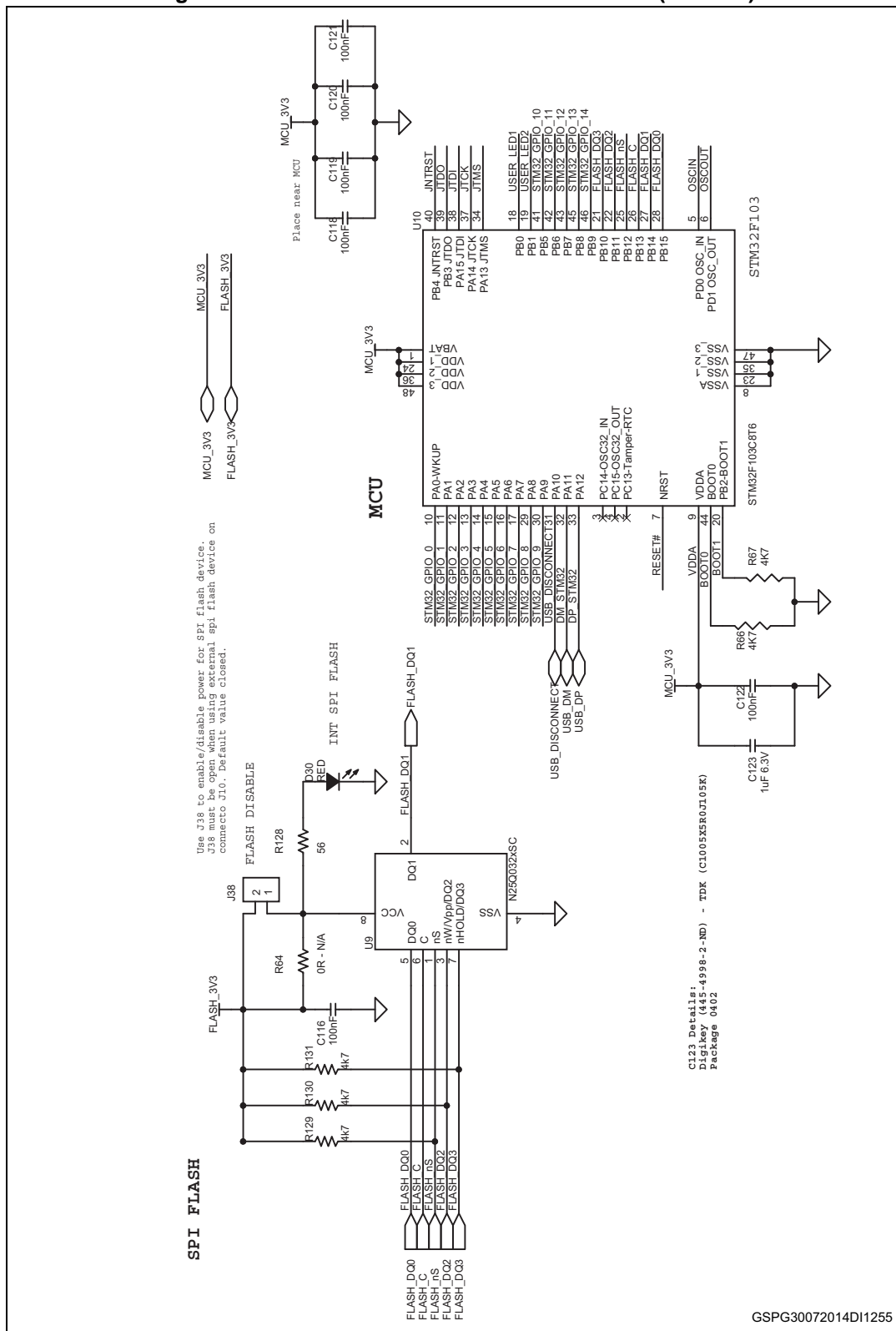
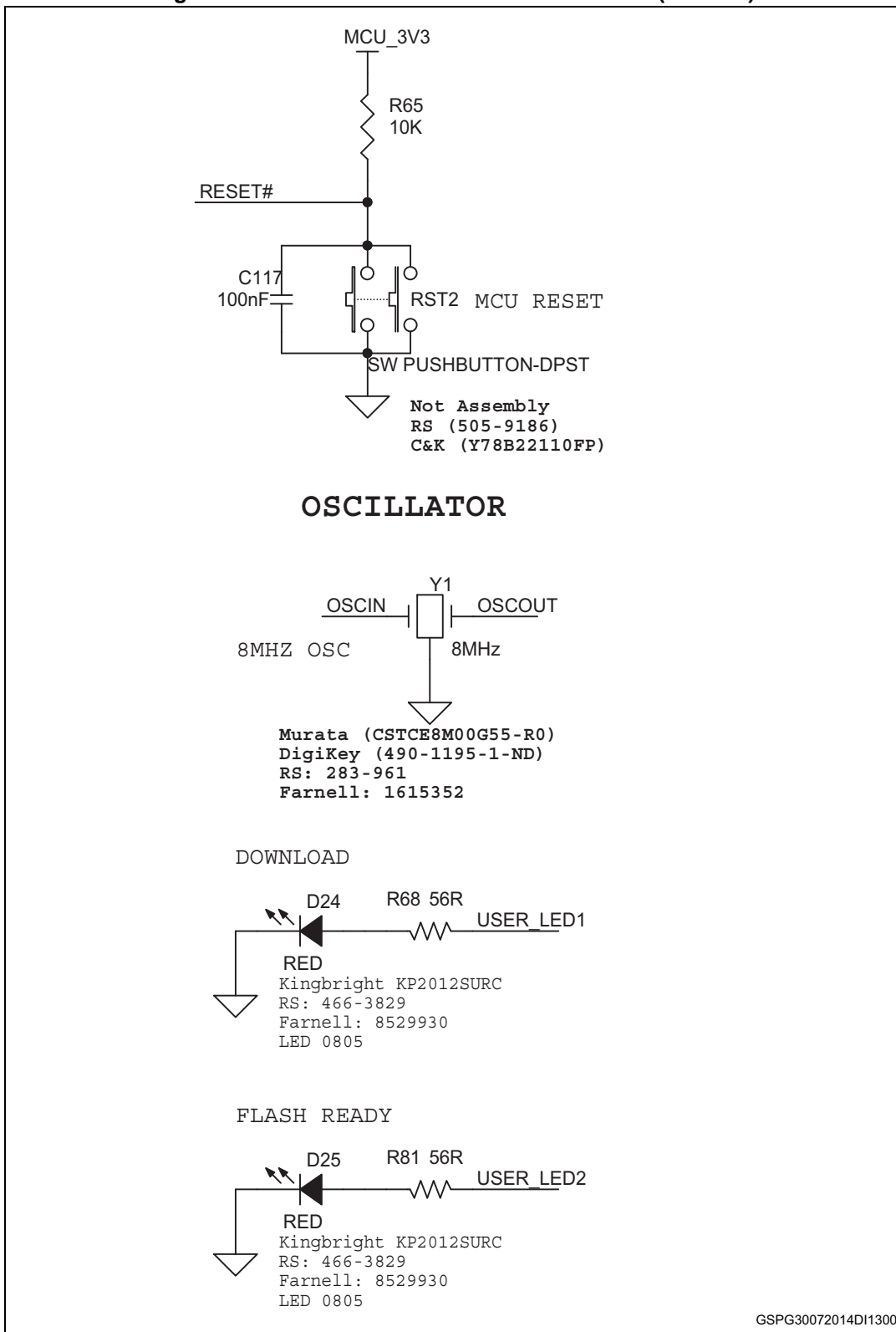



Figure 16. STEVAL-IME008V1 circuit schematic (16 of 16)



## 2 Revision history

Table 1. Document revision history

Date	Revision	Changes
06-Aug-2014	1	Initial release.
06-Aug-2015	2	Updated title on the cover page.

**IMPORTANT NOTICE – PLEASE READ CAREFULLY**

STMicroelectronics NV and its subsidiaries ("ST") reserve the right to make changes, corrections, enhancements, modifications, and improvements to ST products and/or to this document at any time without notice. Purchasers should obtain the latest relevant information on ST products before placing orders. ST products are sold pursuant to ST's terms and conditions of sale in place at the time of order acknowledgement.

Purchasers are solely responsible for the choice, selection, and use of ST products and ST assumes no liability for application assistance or the design of Purchasers' products.

No license, express or implied, to any intellectual property right is granted by ST herein.

Resale of ST products with provisions different from the information set forth herein shall void any warranty granted by ST for such product.

ST and the ST logo are trademarks of ST. All other product or service names are the property of their respective owners.

Information in this document supersedes and replaces information previously supplied in any prior versions of this document.

© 2015 STMicroelectronics – All rights reserved

