

TLE9562-3QX

DC Motor System IC



RoHS



1 Overview

Features

- Low-drop voltage regulator 5 V, 250 mA for main supply
- Four half-bridge gate drivers for external N-channel MOSFETs
- Adaptive MOSFET gate control:
 - Regulation of the MOSFET switching time
 - Reduced switching losses in PWM mode
 - High efficient constant gate charge
- Control of reverse battery protection MOSFET
- High-speed CAN transceiver supporting CAN FD communication up to 5 Mbit/s according to ISO11898-2:2016 including selective wake-up functionality via CAN partial networking and CAN FD tolerant mode
- LIN Transceivers LIN2.2/SAE J2602 with programmable TXD time-out feature and LIN flash mode
- Fail Outputs for fail-safe signalization
- Configurable wake-up sources
- Four high-side outputs 7 Ω typ.
- Two PWM inputs
 - High-side and low-side PWM capable
 - Active free-wheeling
 - Up to 25 kHz PWM frequency
- 32 bit serial peripheral interface (SPI) with cyclic redundancy check (CRC)
- Very low quiescent current consumption in Stop Mode and Sleep Mode
- Periodic cyclic sense and cyclic wake in Normal Mode, Stop Mode and Sleep Mode
- Reset and interrupt output
- Drain-source monitoring and open-load detection
- Configurable time-out and window watchdog
- Overtemperature and short circuit protection features
- Leadless power package with support of optical lead tip inspection
- Green Product (RoHS compliant)

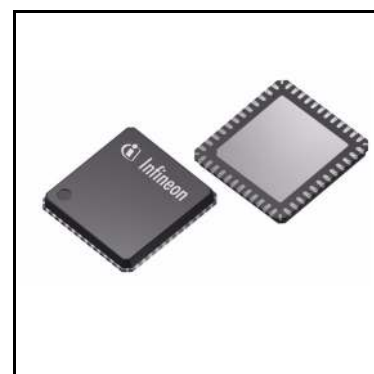

Overview

Potential applications

- Door module
- Power lift gate
- Power sliding doors
- Seat control module
- Seatbelt pretension
- Steering column lock
- Sunroof module

Product validation

Qualified for automotive applications. Product validation according to AEC-Q100.

Description

The TLE9562-3QX is a multifunctional system IC with integrated power supply, communication interfaces, multiple half-bridges and support features in an exposed pad PG-VQFN-48 power package. The device is designed for various motor control automotive applications.

To support these applications, the DC Motor System IC provides the main functions, such as a 5 V low-dropout voltage regulator one HS-CAN transceiver supporting CAN FD, CAN Partial Networking (incl. FD tolerant mode), one LIN transceiver, four half-bridges for DC motor control, and one 32 bit serial peripheral interface (SPI).

The device includes diagnostic and supervision features, such as drain-source monitoring and open-load detection, short circuit protection, configurable time-out and window watchdog, fail-safe output, as well as overtemperature protection.

Type	Package	Marking
TLE9562-3QX	PG-VQFN-48	TLE9562-3QX

Table of Contents

1	Overview	1
2	Block Diagram	8
3	Pin Configuration	9
3.1	Pin Assignment	9
3.2	Pin Definitions and Functions	9
3.3	Hints for not functional pins	11
4	General Product Characteristics	12
4.1	Absolute Maximum Ratings	12
4.2	Functional Range	13
4.3	Thermal Resistance	15
4.4	Current Consumption	15
5	System Features	20
5.1	Short State Machine Description	20
5.2	Device Configuration	21
5.3	Block Description of State Machine	23
5.4	State Machine Modes Description	24
5.4.1	Init Mode	24
5.4.2	Normal Mode	24
5.4.3	Stop Mode	25
5.4.4	Sleep Mode	26
5.4.5	Restart Mode	27
5.4.6	Fail-Safe Mode	28
5.4.7	Software Development Mode	29
5.5	Transition Between States	30
5.5.1	Transition into Init Mode	30
5.5.2	Init Mode -> Normal Mode	30
5.5.3	Normal Mode -> Stop Mode	31
5.5.4	Normal Mode -> Sleep Mode	31
5.5.5	Stop Mode -> Normal Mode	32
5.5.6	Sleep Mode -> Restart Mode	32
5.5.7	Restart Mode -> Normal Mode	32
5.5.8	Fail-Safe Mode -> Restart Mode	33
5.6	Reaction on Detected Faults	33
5.6.1	Stay in Current State	33
5.6.2	Transition into Restart Mode	33
5.6.3	Transition into Fail-Safe Mode	35
5.7	Wake Features	35
5.7.1	Cyclic Sense	36
5.7.1.1	Configuration and Operation of Cyclic Sense	36
5.7.1.2	Cyclic Sense in Low-power Mode	40
5.7.2	Cyclic Wake	40
5.7.3	Internal Timers	41
5.8	VS Supply Multiplexing	42
5.9	Partial Networking on CAN	43
5.9.1	CAN Partial Networking - Selective Wake Feature	43

5.9.2	Partial Networking Function	44
5.9.2.1	Activation of SWK	45
5.9.2.2	Wake-up Pattern (WUP)	46
5.9.2.3	Wake-up Frame (WUF)	46
5.9.2.4	CAN Protocol Error Counter	47
5.9.3	Diagnoses Flags	48
5.9.3.1	PWRON/RESET-FLAG	48
5.9.3.2	BUSERR-Flag	48
5.9.3.3	TXD Dominant Time-out flag	48
5.9.3.4	WUP Flag	48
5.9.3.5	WUF Flag (WUF)	48
5.9.3.6	SYSERR Flag (SYSERR)	48
5.9.3.7	Configuration Error	49
5.9.3.8	CAN Bus Timeout-Flag (CANTO)	49
5.9.3.9	CAN Bus Silence-Flag (CANSIL)	49
5.9.3.10	SYNC-FLAG (SYNC)	49
5.9.3.11	SWK_SET FLAG (SWK_SET)	49
5.9.4	Modes for Selective Wake (SWK)	50
5.9.4.1	Normal Mode with SWK	50
5.9.4.2	Stop Mode with SWK	51
5.9.4.3	Sleep Mode with SWK	52
5.9.4.4	Restart Mode with SWK	53
5.9.4.5	Fail-Safe Mode with SWK	54
5.9.5	Wake-up	54
5.9.6	Configuration for SWK	54
5.9.7	CAN Flexible Data Rate (CAN FD) Tolerant Mode	55
5.9.8	Clock and Data Recovery	57
5.9.8.1	Configuring the Clock Data Recovery for SWK	57
5.9.8.2	Setup of Clock and Data Recovery	58
5.9.9	Electrical Characteristics	59
6	Voltage Regulator 1	61
6.1	Block Description	61
6.2	Functional Description	62
6.3	Electrical Characteristics	63
7	High-Side Switch	65
7.1	Block Description	65
7.2	Functional Description	65
7.2.1	Under Voltage Switch Off	66
7.2.2	Over Voltage Switch Off	66
7.2.3	Over Current Detection and Switch Off	66
7.2.4	Open Load Detection	66
7.2.5	PWM, Timer and SYNC Function	66
7.3	Electrical Characteristics	68
8	High Speed CAN Transceiver	69
8.1	Block Description	69
8.2	Functional Description	69

8.2.1	CAN OFF Mode	71
8.2.2	CAN Normal Mode	71
8.2.3	CAN Receive Only Mode	71
8.2.4	CAN Wake Capable Mode	72
8.2.5	CAN Bus termination	73
8.2.6	TXD Time-out Feature	73
8.2.7	Bus Dominant Clamping	73
8.2.8	Undervoltage Detection	74
8.3	Electrical Characteristics	74
9	LIN Transceiver	81
9.1	Block Description	81
9.1.1	LIN Specifications	81
9.2	Functional Description	82
9.2.1	LIN OFF Mode	82
9.2.2	LIN Normal Mode	82
9.2.3	LIN Receive Only Mode	83
9.2.4	LIN Wake Capable Mode	83
9.2.5	TXD Time-out Feature	84
9.2.6	Bus Dominant Clamping	85
9.2.7	Under-Voltage Detection	85
9.2.8	Slope Selection	85
9.2.9	Flash Programming via LIN	85
9.3	Electrical Characteristics	86
10	High-Voltage Wake Input	91
10.1	Block Description	91
10.2	High-Voltage Wake Function	92
10.2.1	Functional Description	92
10.2.2	Wake Input Configuration	92
10.2.3	Wake configuration for Cyclic Sense	93
10.2.4	Wake configuration for Synchronization	93
10.2.5	Fail Safe Output Configuration	93
10.3	Electrical Characteristics	95
11	Interrupt Function	96
11.1	Block and Functional Description	96
11.2	Electrical Characteristics	99
12	Gate Drivers	100
12.1	MOSFET control	100
12.2	Static activation	101
12.2.1	Static activation of a high-side MOSFET	102
12.2.2	Static activation of a low-side MOSFET	105
12.2.3	Turn-off of the high-side and low-side MOSFETs of a half-bridge	105
12.3	PWM operation	106
12.3.1	Determination of the active and freewheeling MOSFET	106
12.3.2	Configurations in PWM mode	109
12.3.3	PWM mapping	110
12.3.4	PWM operation with adaptive gate control	112

12.3.4.1	High-side PWM with adaptive gate control, motor operating as load	114
12.3.4.2	Low-side PWM with adaptive gate control, motor operating as load	124
12.3.4.3	High-side PWM with adaptive gate control, motor operating as generator	124
12.3.4.4	Low-side PWM with adaptive gate control, motor operating as generator	126
12.3.4.5	Status bits for regulation of turn-on and turn-off delay times	128
12.3.4.6	Time modulation of pre-charge and pre-discharge times	128
12.3.5	PWM operation without adaptive gate control	130
12.3.5.1	AGC[1:0]=00 _B	130
12.3.5.2	AGC[1:0]=01 _B	130
12.3.6	Gate driver current	131
12.3.7	PWM operation at high and low duty cycles with active freewheeling	137
12.3.8	Measurements of the switching times	140
12.4	Passive discharge	140
12.5	Slam mode	141
12.6	Parking braking mode	141
12.7	Charge pump	142
12.8	Frequency modulation	143
12.9	Electrical characteristics gate driver	144
13	Supervision Functions	152
13.1	Reset Function	152
13.1.1	Reset Output Description	152
13.1.2	Soft Reset Description	153
13.2	Watchdog Function	154
13.2.1	Time-Out Watchdog	155
13.2.2	Window Watchdog	156
13.2.3	Watchdog Setting Check Sum	156
13.2.4	Watchdog during Stop Mode	157
13.2.5	Watchdog Start in Stop Mode due to Bus Wake	157
13.3	VSINT Power On Reset	158
13.4	VSINT Under- and Overvoltage	159
13.4.1	VSINT Undervoltage	159
13.4.2	VSINT Overvoltage	159
13.5	VS Under- and Overvoltage	160
13.5.1	VS Undervoltage	160
13.5.2	VS Overvoltage	160
13.6	VSHS Under- Overvoltage	161
13.6.1	VSHS Undervoltage	161
13.6.2	VSHS Overvoltage	161
13.7	VCC1 Over-/ Undervoltage and Undervoltage Prewarning	162
13.7.1	VCC1 Undervoltage and Undervoltage Prewarning	162
13.7.2	VCC1 Overvoltage	163
13.8	VCC1 Short Circuit Diagnostics	163
13.9	VCAN Undervoltage	163
13.10	Thermal Protection	164
13.10.1	Individual Thermal Shutdown	164
13.10.2	Temperature Prewarning	164
13.10.3	Thermal Shutdown	164

13.11	Bridge driver	166
13.11.1	Bridge driver supervision with activated charge pump	166
13.11.1.1	Drain-source voltage monitoring	166
13.11.1.2	Cross-current protection and drain-source overvoltage blank time	167
13.11.1.3	OFF-state diagnostic	168
13.11.1.4	Charge pump undervoltage	169
13.11.1.5	Switching parameters of MOSFETs in PWM mode	169
13.11.2	Low-side drain-source voltage monitoring during braking	170
13.11.3	VS or VSINT Overvoltage braking	170
13.12	Electrical Characteristics	171
14	Serial Peripheral Interface	177
14.1	SPI Block Description	177
14.2	Failure Signalization in the SPI Data Output	178
14.3	SPI Programming	180
14.3.1	CRC	181
14.4	SPI Bit Mapping	183
14.4.1	Register Banking	184
14.5	SPI control registers	186
14.5.1	Device Control Registers	188
14.5.2	Control registers bridge driver	209
14.5.3	Selective Wake Registers	229
14.5.4	Selective Wake trim and configuration Registers	243
14.6	SPI status information registers	248
14.6.1	Device Status Registers	250
14.6.2	Status registers bridge driver	262
14.6.3	Selective wake status registers	276
14.6.4	Family and product information register	279
14.7	Electrical Characteristics	280
15	Application Information	282
15.1	Application Diagrams	282
15.2	ESD Tests	285
15.2.1	ESD according to IEC61000-4-2	285
15.2.2	ESD according to SAE J2962	285
15.3	Thermal Behavior of Package	286
15.4	Further Application Information	286
16	Package Outlines	287
17	Revision History	288

Block Diagram

2 Block Diagram

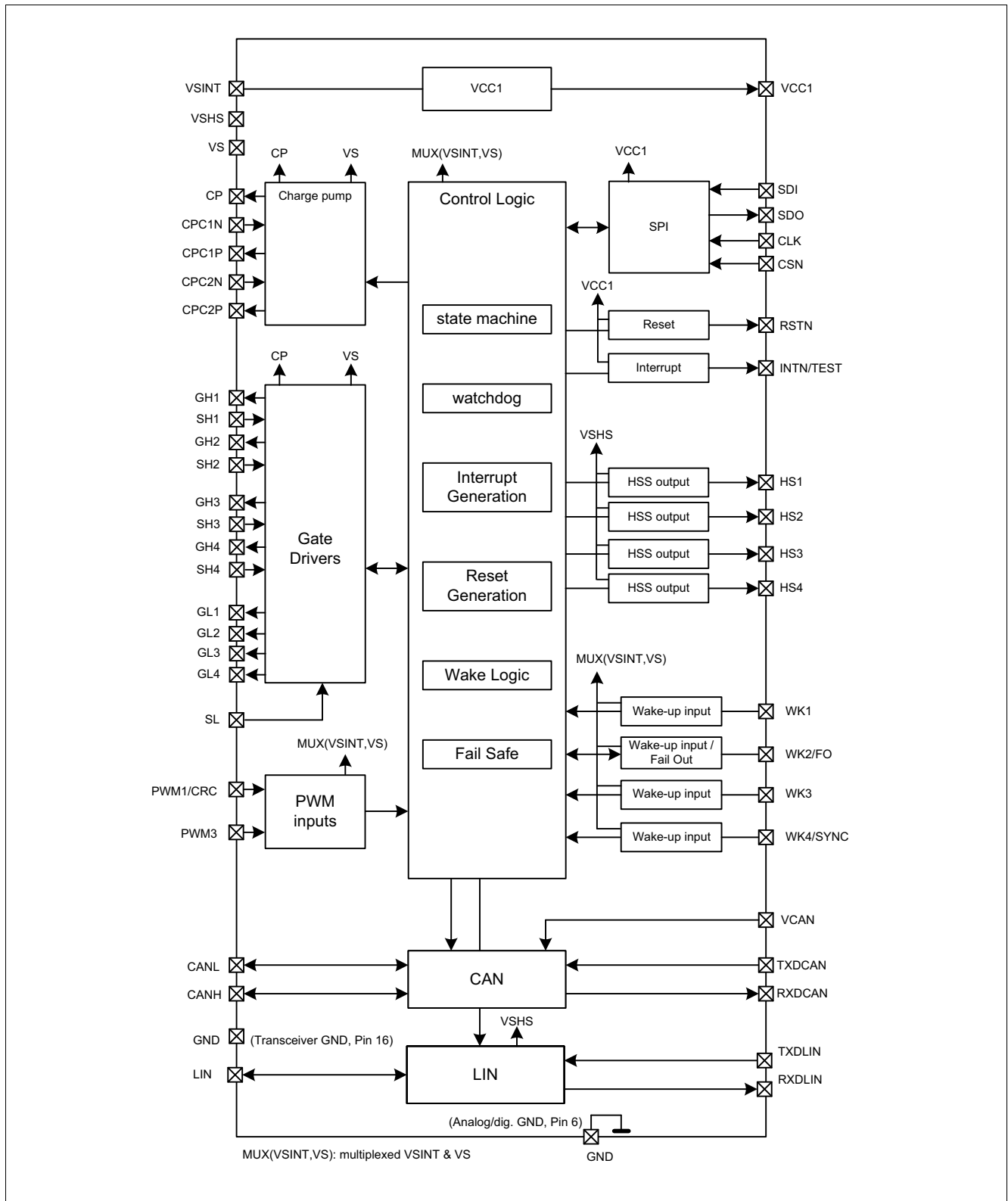

Figure 1 Block Diagram

Pin Configuration

3 Pin Configuration

3.1 Pin Assignment

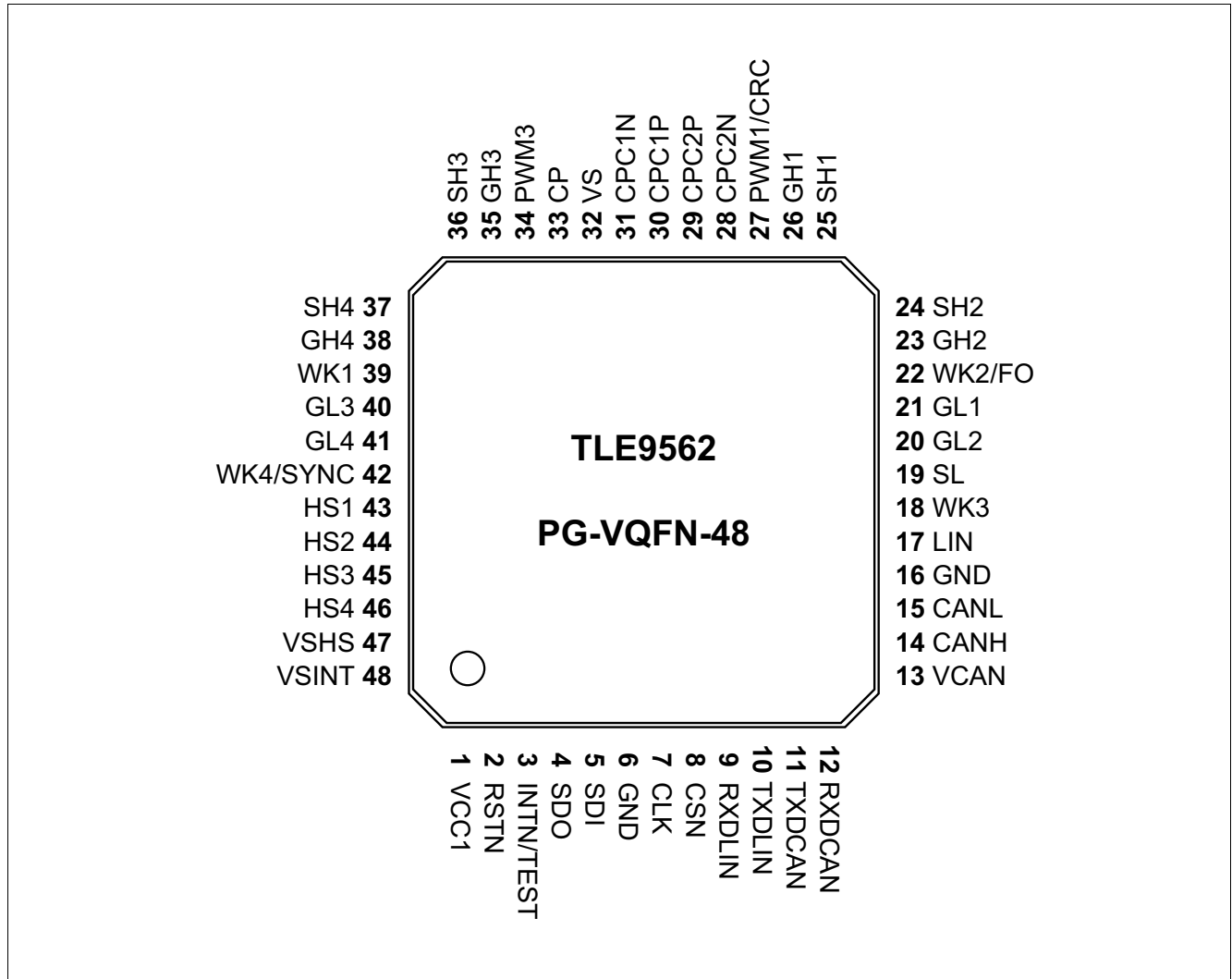

Figure 2 Pin Configuration

3.2 Pin Definitions and Functions

Pin	Symbol	Function
1	VCC1	Voltage Regulator. Output voltage 1
2	RSTN	Reset Output. Active LOW, internally passive pull-up with open-drain output
3	INTN/TEST	Interrupt Output. Active LOW output, push-pull structure TEST. Connect to GND (via pull-down) to activate Software Development Mode
4	SDO	SPI Data Output to Microcontroller (=MISO). Push-pull structure
5	SDI	SPI Data Input from Microcontroller (=MOSI). Internal pull-down
6	GND	Ground. Analog/digital ground
7	CLK	SPI Clock Input. Internal passive pull-down

Pin Configuration

Pin	Symbol	Function
8	CSN	SPI Chip Select Not input. Internal passive pull-up
9	RXDLIN	Receive LIN. Push-pull structure
10	TXDLIN	Transmit LIN. Internal passive pull-up
11	TXDCAN	Transmit CAN. Internal passive pull-up
12	RXDCAN	Receive CAN. Push-pull structure
13	VCAN	HS-CAN Supply Input. For internal HS-CAN cell needed for CAN Normal Mode
14	CANH	CAN High Bus.
15	CANL	CAN Low Bus.
16	GND	Ground. Transceiver ground (CAN, LIN)
17	LIN	LIN Bus.
18	WK3	Wake-up input 3.
19	SL	Source Low Side.
20	GL2	Gate Low Side 2.
21	GL1	Gate Low Side 1.
22	WK2/FO	Wake-up input 2 or Fail Safe Output.
23	GH2	Gate High Side 2.
24	SH2	Source High Side 2.
25	SH1	Source High Side 1.
26	GH1	Gate High Side 1.
27	PWM1/CRC	PWM input 1. Internal passive pull-down CRC. Connect to GND (via pull-down) to activate CRC functionality
28	CPC2N	Negative connection to Charge Pump Capacitor 2.
29	CPC2P	Positive connection to Charge Pump Capacitor 2.
30	CPC1P	Positive connection to Charge Pump Capacitor 1.
31	CPC1N	Negative connection to Charge Pump Capacitor 1.
32	VS	Supply voltage for Bridge Drivers and Charge pump. Connected to the battery voltage after reverse protection.
33	CP	Charge Pump output voltage.
34	PWM3	PWM input 3. Internal passive pull-down
35	GH3	Gate High Side 3.
36	SH3	Source High Side 3.
37	SH4	Source High Side 4.
38	GH4	Gate High Side 4.
39	WK1	Wake-up input 1.
40	GL3	Gate Low Side 3.
41	GL4	Gate Low Side 4.
42	WK4/SYNC	Wake-up input 4/Sync.
43	HS1	High Side output 1.
44	HS2	High Side output 2.

Pin Configuration

Pin	Symbol	Function
45	HS3	High Side output 3.
46	HS4	High Side output 4.
47	VSHS	Supply voltage for HSx and LIN. Connected to the battery voltage after reverse protection
48	VSINT	Voltage regulator and main supply voltage. Connected to the battery voltage after reverse protection
Cooling Tab	GND	Cooling Tab - Exposed Die Pad; For cooling purposes only, do not use as an electrical ground ¹⁾

1) The exposed die pad at the bottom of the package allows better power dissipation of heat from the device via the PCB. The exposed die pad is not connected to any active part of the IC. However, it should be connected to GND for the best EMC performance.

Note: The GND pin as well as the Cooling Tab must be connected to one common GND potential.

3.3 Hints for not functional pins

It must be ensured that the correct configurations are also selected, i.e. in case functions are not used that they are disabled via SPI. Unused pins should be handled as follows:

- **N.U.:** not used; internally bonded for testing purpose; leave open.
- **RSVD:** must be connected to GND.

General Product Characteristics

4 General Product Characteristics

4.1 Absolute Maximum Ratings

Table 1 Absolute Maximum Ratings¹⁾

$T_j = -40^\circ\text{C}$ to $+150^\circ\text{C}$; all voltages with respect to ground, positive current flowing into pin (unless otherwise specified)

Parameter	Symbol	Values			Unit	Note or Test Condition	Number
		Min.	Typ.	Max.			
Voltages							
Supply Voltage VS	$V_{S, \max}$	-0.3	-	28	V	-	P_4.1.1
Supply Voltage VS	$V_{S, \max}$	-0.3	-	40	V	Load Dump	P_4.1.2
Supply Voltage VSINT	$V_{SINT, \max}$	-0.3	-	28	V	-	P_4.1.3
Supply Voltage VSINT	$V_{SINT, \max}$	-0.3	-	40	V	Load Dump	P_4.1.4
Supply Voltage VSHS	$V_{SHS, \max}$	-0.3	-	28	V	-	P_4.1.5
Supply Voltage VSHS	$V_{SHS, \max}$	-0.3	-	40	V	Load Dump	P_4.1.6
Voltage Regulator 1	$V_{CC1, \max}$	-0.3	-	5.5	V		P_4.1.7
Charge Pump Output Pin (CP)	$V_{CP, \max}$	$V_S - 0.8$	-	$V_S + 17$	V	$I_{CP} > -200 \mu\text{A}$ if CP is disabled	P_4.1.8
CPC1P, CPC2P	$V_{CPCxP, \max}$	-0.3	-	$V_S + 17$	V		P_4.1.38
CPC1N, CPC2N	$V_{CPCxN, \max}$	-0.3	-	$V_S + 0.3$	V		P_4.1.39
Bridge Driver Gate High Side (GHx)	$V_{GHx, \max}$	-8.0	-	40	V	-	P_4.1.11
Bridge Driver Gate Low Side (GLx)	$V_{GLx, \max}$	-8.0	-	24	V	-	P_4.1.12
Voltage difference between GHx-SHx and between GLx-SLx	V_{GS}	-0.3	-	16	V	-	P_4.1.13
Bridge Driver Source High (SHx)	$V_{SHx, \max}$	-8.0	-	40	V	-	P_4.1.14
Bridge Driver Source Low Side SL	$V_{SL, \max}$	-8.0	-	6.0	V	-	P_4.1.15
Wake Input WKx	$V_{WKx, \max}$	-0.3	-	40	V	-	P_4.1.19
High Side HSx	$V_{HSx, \max}$	-0.3	-	$V_{SHS, \max} + 0.3$	V	-	P_4.1.20
LIN bus	$V_{LIN, \max}$	-27	-	40	V	-	P_4.1.21
CANH, CANL	$V_{BUS, \max}$	-27	-	40	V	-	P_4.1.22
PWM1/CRC, PWM3 Input Pins	$V_{PWM1-3, \max}$	-0.3	-	40	V	-	P_4.1.23
Logic Input Pins (CSN, CLK, SDI, TXDCAN, TXDLIN)	$V_{I, \max}$	-0.3	-	$V_{CC1} + 0.3$	V	-	P_4.1.27

General Product Characteristics

Table 1 Absolute Maximum Ratings¹⁾ (cont'd)

$T_j = -40^\circ\text{C}$ to $+150^\circ\text{C}$; all voltages with respect to ground, positive current flowing into pin (unless otherwise specified)

Parameter	Symbol	Values			Unit	Note or Test Condition	Number
		Min.	Typ.	Max.			
Logic Output Pins (SDO, RSTN, INTN, RXDCAN, RXDLIN)	$V_{O,max}$	-0.3	–	$V_{CC1} + 0.3$	V	–	P_4.1.30
VCAN Input Voltage	$V_{VCAN,max}$	-0.3	–	5.5	V		P_4.1.31

Temperatures

Junction Temperature	T_j	-40	–	150	°C	–	P_4.1.32
Storage Temperature	T_{stg}	-55	–	150	°C	–	P_4.1.33

ESD Susceptibility

ESD Resistivity	$V_{ESD,11}$	-2	–	2	kV	HBM ²⁾	P_4.1.34
ESD Resistivity to GND, CANH, CANL, LIN	$V_{ESD,12}$	-8	–	8	kV	HBM ²⁾³⁾	P_4.1.35
ESD Resistivity to GND	$V_{ESD,21}$	-500	–	500	V	CDM ⁴⁾	P_4.1.36
ESD Resistivity Pin 1, 12,13,24,25,36,37,48 (corner pins) to GND	$V_{ESD,22}$	-750	–	750	V	CDM ⁴⁾	P_4.1.37

- 1) Not subject to production test, specified by design.
- 2) ESD susceptibility, HBM according to ANSI/ESDA/JEDEC JS-001 (1.5 kΩ, 100 pF).
- 3) For ESD “GUN” Resistivity (according to IEC61000-4-2 “gun test” (150 pF, 330 Ω)), is shown in Application Information and test report will be provided from IBEE.
- 4) ESD susceptibility, Charged Device Model “CDM” EIA/JESD22-C101 or ESDA STM5.3.1.

Notes

1. Stresses above the ones listed here may cause permanent damage to the device. Exposure to absolute maximum rating conditions for extended periods may affect device reliability.
2. Integrated protection functions are designed to prevent IC destruction under fault conditions described in the data sheet. Fault conditions are considered as “outside” normal operating range. Protection functions are not designed for continuous repetitive operation.

4.2 Functional Range

Table 2 Functional Range¹⁾

Parameter	Symbol	Values			Unit	Note or Test Condition	Number
		Min.	Typ.	Max.			
Supply Voltage	$V_{SINT,func}$	$V_{POR,f}$	–	28	V	²⁾	P_4.2.1
Bridge Supply Voltage	$V_{S,func}$	6.0	–	28	V	–	P_4.2.2
High Side Supply Voltage	$V_{SHS_HS,func}$	6.0	–	28	V	²⁾	P_4.2.7
LIN Bus Voltage	$V_{SHS_LIN,func}$	6	–	18	V	³⁾	P_4.2.3
CAN Supply Voltage	$V_{CAN,func}$	4.75	–	5.25	V	–	P_4.2.4
Junction Temperature	T_j	-40	–	150	°C	–	P_4.2.6

General Product Characteristics

- 1) Not subject to production test, specified by design.
- 2) Including Power-On Reset, Over- and Undervoltage Protection.
- 3) Parameter specification according to ISO 17987-4: rev 2016.

Note: Within the functional range the IC operates as described in the circuit description. The electrical characteristics are specified within the conditions given in the related electrical characteristics table.

Device Behavior Outside of Specified Functional Range

- $28\text{ V} < V_{\text{SINT,func}} < 40\text{ V}$: Device will still be functional including the state machine; the specified electrical characteristics might not be ensured anymore. The V_{CC1} is working properly, however, a thermal shutdown might occur due to high power dissipation. HSx switches might be turned OFF depending on HSx_OV configurations. The specified SPI communication speed is ensured; the absolute maximum ratings are not violated, however the device is not intended for continuous operation of $V_{\text{SINT}} > 28\text{ V}$ and a thermal shutdown might occur due to high power dissipation. The device operation at high junction temperatures for long periods might reduce the operating life time.

Note: $18\text{ V} < V_{\text{SHS}} < 28\text{ V}$: The LIN transceiver is still functional. However, the communication might fail due to out-of-LIN-spec operation.

Note: $V_{\text{SHS,UVD}} < V_{\text{SHS}} < 6\text{ V}$: The LIN transceiver is still functional. However, the communication might fail due to out-of-LIN-spec operation.

Note: $V_{\text{CAN}} < 4.75\text{ V}$: The undervoltage bit will be set in the SPI register and the transmitter will be disabled as long as the UV condition is present.

Note: $5.25\text{ V} < V_{\text{CAN}} < 5.5\text{ V}$: CAN transceiver still functional. However, the communication might fail due to out-of-spec operation.

- $V_{\text{POR,f}} < V_{\text{SINT}} < 5.5\text{ V}$ (given the fact that the device was powered up correctly before with $V_{\text{SINT}} > 5.5\text{ V}$): Device will still be functional; the specified electrical characteristics might not be ensured anymore:
 - The voltage regulator will enter the low-drop operation mode.
 - A reset could be triggered depending on the Vrthx settings.
 - The LIN transmitter will be disabled if $V_{\text{SHS,UVD}}$ is reached. .
 - HSx switch behavior will depend on the respective configuration:
 - HS_UV_SD_DIS** = '0' (default): HSx will be turned OFF for $V_{\text{SHS}} < V_{\text{SHS,UVD}}$ and will stay OFF.
 - HS_UV_SD_DIS** = '1': HSx stays on as long as possible. An unwanted overcurrent shut down may occur. OC shut down bit set and the respective HSx switch will stay OFF.
 - If WK2/FO is configured as Fail Safe Output, FO outputs will remain ON if they were enabled before $V_{\text{SINT}} > 5.5\text{ V}$.
 - The specified SPI communication speed is ensured.

Note: $V_{\text{s,uv}} < V_{\text{s}} < 6.0\text{ V}$: the charge pump might be deactivated due to a charge pump undervoltage detection, resulting in a turn-off of the external MOSFETs.

General Product Characteristics

4.3 Thermal Resistance

Table 3 Thermal Resistance¹⁾

Parameter	Symbol	Values			Unit	Note or Test Condition	Number
		Min.	Typ.	Max.			
Junction to Soldering Point	$R_{th(JSP)}$	–	7.2	–	K/W	Exposed Pad	P_4.3.1
Junction to Ambient	$R_{th(JA)}$	–	27	–	K/W	²⁾	P_4.3.2

1) Not subject to production test, specified by design.

2) Specified $R_{th(JA)}$ value is according to Jedec JESD51-2,-5,-7 at natural convection on FR4 2s2p board for a power dissipation of 1.5 W; the product (chip+package) was simulated on a 76.2 x 114.3 x 1.5 mm³ with 2 inner copper layers (2 x 70 μm Cu, 2 x 35 μm C); where applicable a thermal via array under the exposed pad contacted the first inner copper layer and 300 mm² cooling areas on the top layer and bottom layers (70 μm).

4.4 Current Consumption

Table 4 Current Consumption

Current consumption values are specified at $T_j = 25^\circ\text{C}$, $V_{SINT} = V_{SHS} = 13.5\text{ V}$, all outputs open (unless otherwise specified)

Parameter	Symbol	Values			Unit	Note or Test Condition	Number
		Min.	Typ.	Max.			
Normal Mode							
Normal Mode current consumption	I_{Normal}	–	4.5	5.5	mA	¹⁾ $V_{SINT} = 5.5\text{ V to }28\text{ V}$; $T_j = -40^\circ\text{C to }+150^\circ\text{C}$; CAN=LIN=CP=off	P_4.4.1
Stop Mode							
Stop Mode current consumption (low active peak threshold)	$I_{Stop_1,25}$	–	50	65	μA	¹⁾²⁾ CAN ³⁾ =LIN=off; WKx=HSx=CP=off; Cyclic Wak./Sen.=off Watchdog = off; no load on V_{CC1} ; I_PEAK_TH = 0 _B	P_4.4.2
Stop Mode current consumption (low active peak threshold)	$I_{Stop_1,85}$	–	55	80	μA	¹⁾²⁾⁴⁾ $T_j = 85^\circ\text{C}$; CAN ³⁾ =LIN=off; WKx=HSx=CP=off; Cyclic Wak./Sen.=off Watchdog = off; no load on V_{CC1} ; I_PEAK_TH = 0 _B	P_4.4.3
Stop Mode current consumption (high active peak threshold)	$I_{Stop_2,25}$	–	70	95	μA	¹⁾²⁾ CAN ³⁾ =LIN=off; WKx=HSx=CP=off; Cyclic Wak./Sen.=off Watchdog = off; no load on V_{CC1} ; I_PEAK_TH = 1 _B	P_4.4.4

General Product Characteristics

Table 4 Current Consumption (cont'd)

Current consumption values are specified at $T_j = 25^\circ\text{C}$, $V_{\text{SINT}} = V_{\text{SHS}} = 13.5\text{ V}$, all outputs open (unless otherwise specified)

Parameter	Symbol	Values			Unit	Note or Test Condition	Number
		Min.	Typ.	Max.			
Stop Mode current consumption (high active peak threshold)	$I_{\text{Stop}_2,85}$	–	75	105	μA	¹⁾²⁾⁴⁾ $T_j = 85^\circ\text{C}$; CAN ³⁾ =LIN=off; Cyclic Wak./Sen.=off; Watchdog = off; no load on V_{CC1} ; I_PEAK_TH = 1 _B	P_4.4.5

Sleep Mode

Sleep Mode current consumption	$I_{\text{Sleep},25}$	–	18	30	μA	¹⁾ CAN ³⁾ =LIN=off; WKx=HSx=CP=off; Cyclic Wak./Sen.= off	P_4.4.6
Sleep Mode current consumption	$I_{\text{Sleep},85}$	–	28	40	μA	¹⁾⁴⁾ $T_j = 85^\circ\text{C}$; CAN ³⁾ =LIN=off; WKx=HSx=CP=off; Cyclic Wak./Sen.=off	P_4.4.7

Feature Incremental Current Consumption

Current consumption for LIN module, recessive state	$I_{\text{LIN,rec}}$	–	1.0	1.2	mA	⁴⁾⁵⁾ Normal/Stop Mode; LIN Normal Mode; $T_j = -40^\circ\text{C}$ to $+150^\circ\text{C}$; $V_{\text{TXDLIN}} = V_{\text{CC1}}$; no RL on LIN	P_4.4.8
Current consumption for LIN module, dominant state	$I_{\text{LIN,dom}}$	–	1.5	1.7	mA	⁴⁾⁵⁾ Normal/Stop Mode; LIN Normal Mode; $T_j = -40^\circ\text{C}$ to $+150^\circ\text{C}$; $V_{\text{TXDLIN}} = \text{GND}$; no RL on LIN	P_4.4.9
Current consumption for LIN module, Receive Only Mode, Normal Mode	$I_{\text{LIN,Rec_onlyN}}$	–	0.1	0.2	mA	⁴⁾⁵⁾ Normal Mode; LIN Receive Only Mode; $V_{\text{TXDLIN}} = V_{\text{CC1}}$ no RL on LIN	P_4.4.10
Current consumption for LIN wake capability	$I_{\text{LIN,wake},25}$	–	0.2	2	μA	⁵⁾ Stop/Sleep Mode; LIN wake capable;	P_4.4.11
Current consumption for LIN wake capability	$I_{\text{LIN,wake},85}$	–	2	3	μA	⁴⁾⁵⁾ Stop/Sleep Mode; $T_j = 85^\circ\text{C}$; LIN wake capable;	P_4.4.12

General Product Characteristics

Table 4 Current Consumption (cont'd)

Current consumption values are specified at $T_j = 25^\circ\text{C}$, $V_{\text{SINT}} = V_{\text{SHS}} = 13.5\text{ V}$, all outputs open (unless otherwise specified)

Parameter	Symbol	Values			Unit	Note or Test Condition	Number
		Min.	Typ.	Max.			
Current consumption for CAN module, recessive state	$I_{\text{CAN,rec}}$	–	2	3.5	mA	¹⁾⁴⁾ Normal/Stop Mode; CAN Normal Mode; $T_j = -40^\circ\text{C}$ to $+150^\circ\text{C}$; V_{CC1} connected to V_{CAN} ; $V_{\text{TXDCAN}} = V_{\text{CC1}}$; no RL on CAN	P_4.4.13
Current consumption for CAN module, dominant state	$I_{\text{CAN,dom}}$	–	3	5.0	mA	¹⁾⁴⁾ Normal/Stop Mode; CAN Normal Mode; $T_j = -40^\circ\text{C}$ to $+150^\circ\text{C}$; V_{CC1} connected to V_{CAN} ; $V_{\text{TXDCAN}} = \text{GND}$; no RL on CAN	P_4.4.14
Current consumption for CAN module, Receive Only Mode, Normal Mode	$I_{\text{CAN,Rec_onlyN}}$	–	0.5	0.7	mA	¹⁾⁴⁾⁶⁾ Normal Mode; CAN Receive Only Mode; $T_j = -40^\circ\text{C}$ to $+150^\circ\text{C}$; V_{CC1} connected to V_{CAN} ; $V_{\text{TXDCAN}} = V_{\text{CC1}}$; no RL on CAN	P_4.4.15
Current consumption for CAN module, Receive Only Mode, Stop Mode	$I_{\text{CAN,Rec_only}}$	–	1.4	1.5	mA	¹⁾⁴⁾⁶⁾ Stop Mode; CAN Receive Only Mode; $T_j = -40^\circ\text{C}$ to $+150^\circ\text{C}$; V_{CC1} connected to V_{CAN} ; $V_{\text{TXDCAN}} = V_{\text{CC1}}$; no RL on CAN	P_4.4.16
Current consumption for CAN wake capability (tsilence expired)	$I_{\text{CAN,wake,25}}$	–	4.5	7	μA	¹⁾³⁾⁷⁾ Sleep Mode; CAN wake capable;	P_4.4.17
Current consumption for CAN wake capability (tsilence expired)	$I_{\text{CAN,wake,85}}$	–	8	10	μA	¹⁾³⁾⁴⁾⁷⁾ Sleep Mode; $T_j = 85^\circ\text{C}$; CAN wake capable; WK = off;	P_4.4.18

General Product Characteristics

Table 4 Current Consumption (cont'd)

Current consumption values are specified at $T_j = 25^\circ\text{C}$, $V_{\text{SINT}} = V_{\text{SHS}} = 13.5\text{ V}$, all outputs open (unless otherwise specified)

Parameter	Symbol	Values			Unit	Note or Test Condition	Number
		Min.	Typ.	Max.			
Current consumption during CAN Partial Networking frame detect mode (RX_WK_SEL= '0')	$I_{\text{CAN,SWK,25}}$	–	475	550	μA	¹⁾⁴⁾ $T_j = 25^\circ\text{C}$; Stop Mode; WK, CAN SWK wake capable, SWK Receiver enabled, WUF detect; no RL on CAN;	P_4.4.19
Current consumption during CAN Partial Networking frame detect mode (RX_WK_SEL= '0')	$I_{\text{CAN,SWK,85}}$	–	500	575	μA	¹⁾⁴⁾ $T_j = 85^\circ\text{C}$; Stop Mode; WK, CAN SWK wake capable, SWK Receiver enabled, WUF detect; no RL on CAN;	P_4.4.20
Current consumption for each WK input	$I_{\text{WK,wake,25}}$	–	0.2	2	μA	¹⁾⁷⁾⁸⁾⁹⁾ Sleep Mode; WK wake capable; no activity on WK pin;	P_4.4.22
Current consumption for each WK input	$I_{\text{WK,wake,85}}$	–	0.5	3	μA	¹⁾⁴⁾⁷⁾⁸⁾⁹⁾ Sleep Mode; $T_j = 85^\circ\text{C}$; WK wake capable; no activity on WK pin;	P_4.4.23
Current consumption for first High-Side in Stop Mode	$I_{\text{Stop,HS,25}}$	–	250	375	μA	⁴⁾⁷⁾¹⁰⁾¹²⁾¹¹⁾ Stop Mode; HS with 100% duty cycle (no load);	P_4.4.24
Current consumption for first High-Side in Stop Mode	$I_{\text{Stop,HS,85}}$	–	250	375	μA	⁴⁾⁷⁾¹⁰⁾¹²⁾¹¹⁾ Stop Mode; $T_j = 85^\circ\text{C}$; HS with 100% duty cycle (no load);	P_4.4.25
Current consumption for cyclic sense function	$I_{\text{Stop,CS25}}$	–	20	26	μA	⁷⁾¹⁰⁾¹²⁾¹³⁾ Stop Mode; WD = off;	P_4.4.26
Current consumption for cyclic sense function	$I_{\text{Stop,CS85}}$	–	24	32	μA	⁴⁾⁷⁾¹⁰⁾¹²⁾¹³⁾ Stop Mode; $T_j = 85^\circ\text{C}$; WD = off;	P_4.4.27
Current consumption for watchdog active in Stop Mode	$I_{\text{Stop,WD25}}$	–	18	23	μA	⁴⁾¹⁴⁾ Stop Mode; Watchdog running;	P_4.4.28
Current consumption for watchdog active in Stop Mode	$I_{\text{Stop,WD85}}$	–	19	25	μA	⁴⁾¹⁴⁾ Stop Mode; $T_j = 85^\circ\text{C}$; Watchdog running;	P_4.4.29

General Product Characteristics

Table 4 Current Consumption (cont'd)

Current consumption values are specified at $T_j = 25^\circ\text{C}$, $V_{\text{SINT}} = V_{\text{SHS}} = 13.5\text{ V}$, all outputs open (unless otherwise specified)

Parameter	Symbol	Values			Unit	Note or Test Condition	Number
		Min.	Typ.	Max.			
Current consumption for active Fail Output FO	$I_{\text{Stop,FO}}$	–	350	600	μA	⁴⁾¹⁴⁾ all modes; $T_j < 85^\circ\text{C}$; FO = on (no load);	P_4.4.30
Current consumption in parking braking mode (LSx ON)	I_{parking}	–	10	14	μA	⁴⁾¹⁴⁾ Stop Mode or Sleep Mode; $T_j < 85^\circ\text{C}$; PARK_BRK_EN = 1 _B	P_4.4.32
Current consumption Over voltage braking mode (LSx OFF)	$I_{\text{OV,LS_OFF}}$	–	7	10	μA	⁴⁾¹⁴⁾ Stop Mode or Sleep Mode; $T_j < 85^\circ\text{C}$; OV_BRK_EN = 1 _B	P_4.4.34
Current consumption in VS for Charge Pump and Bridge Driver	$I_{\text{CP,BD}}$	–	30	40	mA	Normal Mode; $T_j = -40^\circ\text{C}$ to $+150^\circ\text{C}$; CPEN = 1; All HB OFF	P_4.4.35

- 1) Measured at V_{SINT} .
- 2) If the load current on V_{CC1} will exceed the configured V_{CC1} active peak threshold, the current consumption will increase by typ. 2.9 mA to ensure optimum dynamic load behavior. See also [Chapter 6](#).
- 3) CAN not configured in Selective Wake Mode.
- 4) Not subject to production test, specified by design.
- 5) Additional current will be drawn from VSHS.
- 6) Current consumption adder also applies for during WUF detection (frame detect mode) when CAN Partial Networking is activated.
- 7) Current consumption adders of features defined for Stop Mode also apply for Sleep Mode and vice versa. Wake input signals are stable (i.e. not toggling), cyclic wake/sense & watchdog are OFF (unless otherwise specified).
- 8) No pull-up or pull-down configuration selected.
- 9) The specified WKx current consumption adder for wake capability applies regardless how many WK inputs are activated.
- 10) Additional current will be drawn from V_{SHS} and V_{SINT} .
- 11) Typical adder of additional high-side switch activation 200 μA .
- 12) HSx used for cyclic sense, Timerx with 20ms period, 0.1 ms on-time, no load.
In general the current consumption adder for cyclic sense in Stop Mode can be calculated with below equation:
$$I_{\text{Stop,CS_typ}} = 18\ \mu\text{A} + (I_{\text{Stop,HS,25}} \times t_{\text{on}}/T_{\text{Per}})$$
where the 18 μA is the base current consumption of the digital cyclic sense/wake functionality.
- 13) Also applies to cyclic wake but without adder from HS biasing contribution.
- 14) Additional current will be drawn from V_{SINT} .

Notes

1. There is no additional current consumption contribution in Normal Mode due to PWM generators or Timers.
2. The quiescent current consumption in Stop Mode and Sleep Mode will increase for $V_{\text{SINT}} < 9\text{ V}$.

5 System Features

This chapter describes the system features and behavior of the TLE9562-3QX:

- State machine
- Device configuration
- State machine modes and mode transitions
- Wake-up features such as cyclic sense and cyclic wake

5.1 Short State Machine Description

The DC Motor System IC offers six operating modes:

- Init Mode: Power-up of the device and after a soft reset.
- Normal Mode: The main operating mode of the device.
- Stop Mode: The first-level power saving mode with the main voltage regulator VCC1 enabled.
- Sleep Mode: The second-level power saving mode with VCC1 disabled.
- Restart Mode: An intermediate mode after a wake event from Sleep Mode or Fail-Safe Mode or after a failure (e.g. WD failure, VCC1 under voltage reset) to bring the microcontroller into a defined state via a reset.
- Fail-Safe Mode: A safe-state mode after critical failures (e.g. Temperature shutdown) to bring the system into a safe state and to ensure a proper restart of the system.

A special mode, called Software Development Mode, is available during software development or debugging of the system. All above mentioned operating modes can be accessed in this mode. However, the watchdog is still running, but no reset to the microcontroller is applied. Watchdog failures are indicated over INTN pin instead.

However, the watchdog reset signaling can be reactivated again in Software Development Mode. The Watchdog will start always with the Long Open Windows (t_{low}).

The DC Motor System IC is controlled via a 32-bit SPI interface (refer to [Chapter 14](#) for detailed information). The configuration as well as the diagnosis is handled via the SPI.

The device offers various supervision features to support functional safety requirements. Refer to [Chapter 13](#) for more information.

System Features

5.2 Device Configuration

Two features on the DC Motor System IC can be configured by hardware:

- The selection of the normal device operation or the Software Development Mode.
- Enabling/disabling the CRC on the SPI interface.

The configurations are done monitoring the follow pins:

- INTN/TEST
- PWM1/CRC

The hardware configuration can be done typically at device power-up, where the device is in Init Mode or (only in case of CRC setting) in Restart Mode.

Software development Mode configuration detail

After the RSTN is released, the INTN/TEST pin is internally pulled HIGH with a weak pull-up resistor. Therefore the default configuration is the device in normal operation.

In order to configure the Software Development Mode, the following conditions have to be fulfilled:

- Init Mode from power-up
- $VCC1 > V_{rtx}$
- **POR**=1
- RSTN = HIGH

The Software Development Mode is configured using the following scheme:

- Only one external pull-down on INTN/TEST pin followed by an arbitrary SPI command, the device latches the Software Development Mode.
- External pull-up or no pull-down on INTN/TEST pin enable the device in normal operation.
- To enter Software Development Mode, a pull-down resistor to GND might be used.

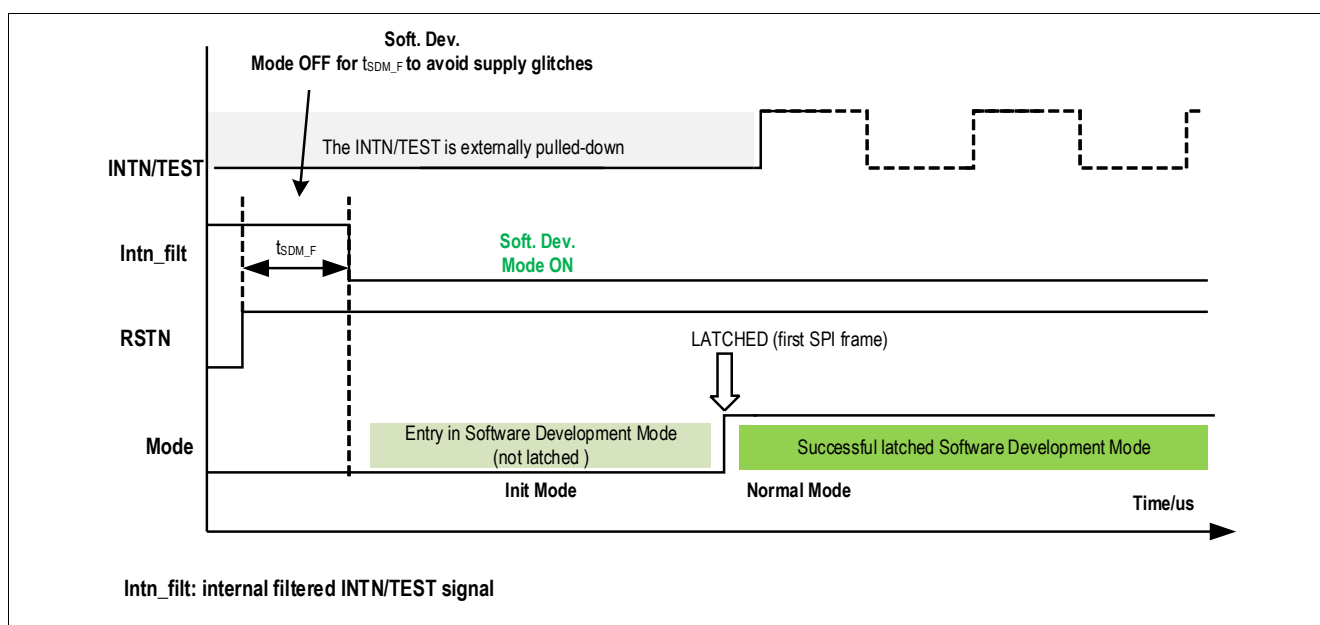

Figure 3 Software Development Mode Selection Timing

Intn_filt is a filtered signal from INTN/TEST, with the filter time t_{SMD_F} (P_11.2.7). Intn_filt starts (at the rising edge if RSNT) with the value 1.

System Features

Note: If during monitoring the INTN/TEST pin for Software Development Mode entry, the device changes the mode without SPI command, the device will not enter/stay in Software Development Mode.

CRC configuration detail

The CRC is configured using the following scheme:

- Pull-down on PWM1/CRC enable the CRC.
- No external components on PWM1/CRC disables the CRC.

In order to configure the CRC, the follow conditions have to be full filled:

- Init Mode (from power-up) or Restart Mode
- $VCC1 > V_{rtx}$
- **POR**=1
- **RSTN** = LOW

The configuration selection is done during the reset delay time t_{RD1} with a continuous filter time of t_{CFG_F} and the configuration (depending on the voltage level at PWM1/CRC) is latched at the rising edge of RSTN.

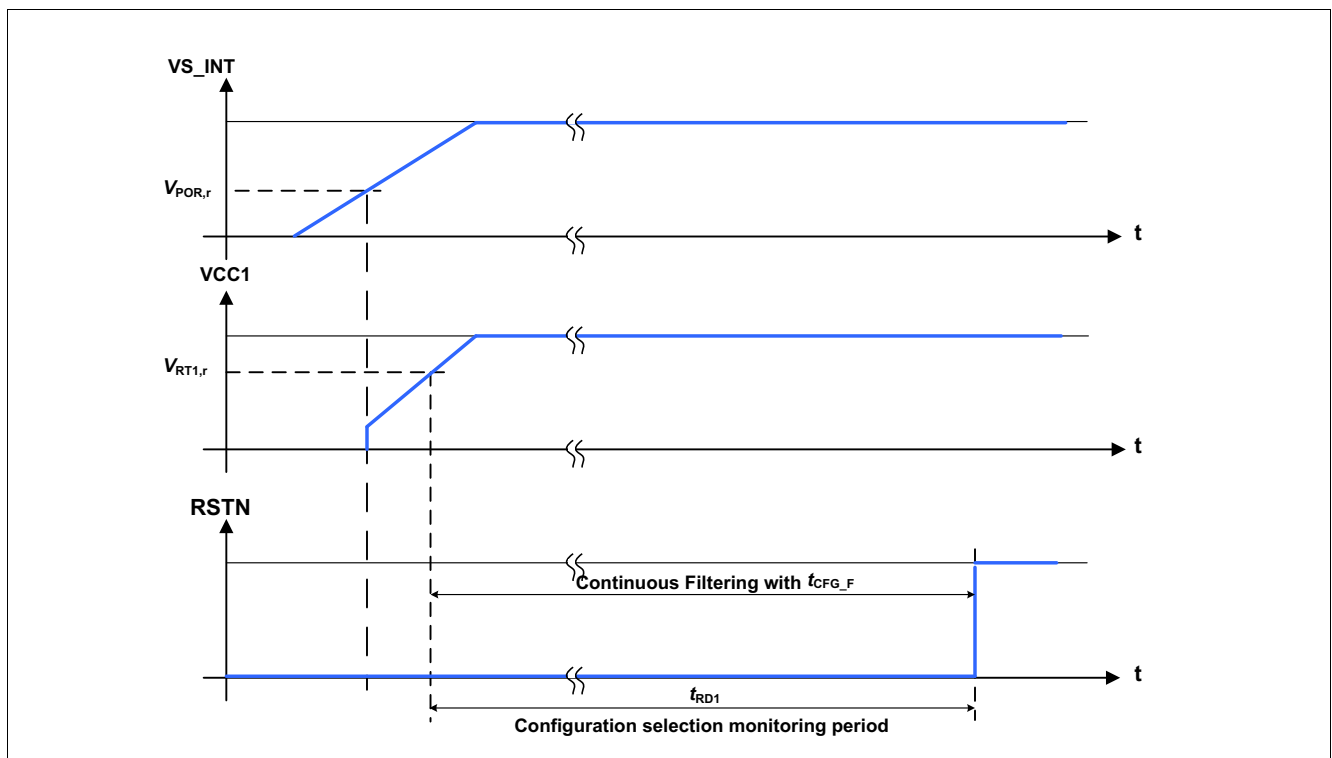

Figure 4 CRC configuration Selection Timing Diagram at the device power-up.

In case of mismatch between CRC setting between the device and μC (**CRC_STAT**), the device can accept two recovery SPI commands (static patterns).

The pattern 67AA AA0E_H (addr + rw_bit = 67 ; data = AAAA ; CRC = 0E) enables the CRC.

The pattern E7AA AAC3_H (addr + rw_bit = E7 ; data = AAAA ; CRC = C3) disables the CRC.

The patterns shall be send only in Normal Mode.

For additional details about the CRC setting and configuration, refer also to **Chapter 14.3.1**.

System Features

5.3 Block Description of State Machine

The state machine describes the different states of operation, the device may get into. The following figure shows the state machine flow diagram.

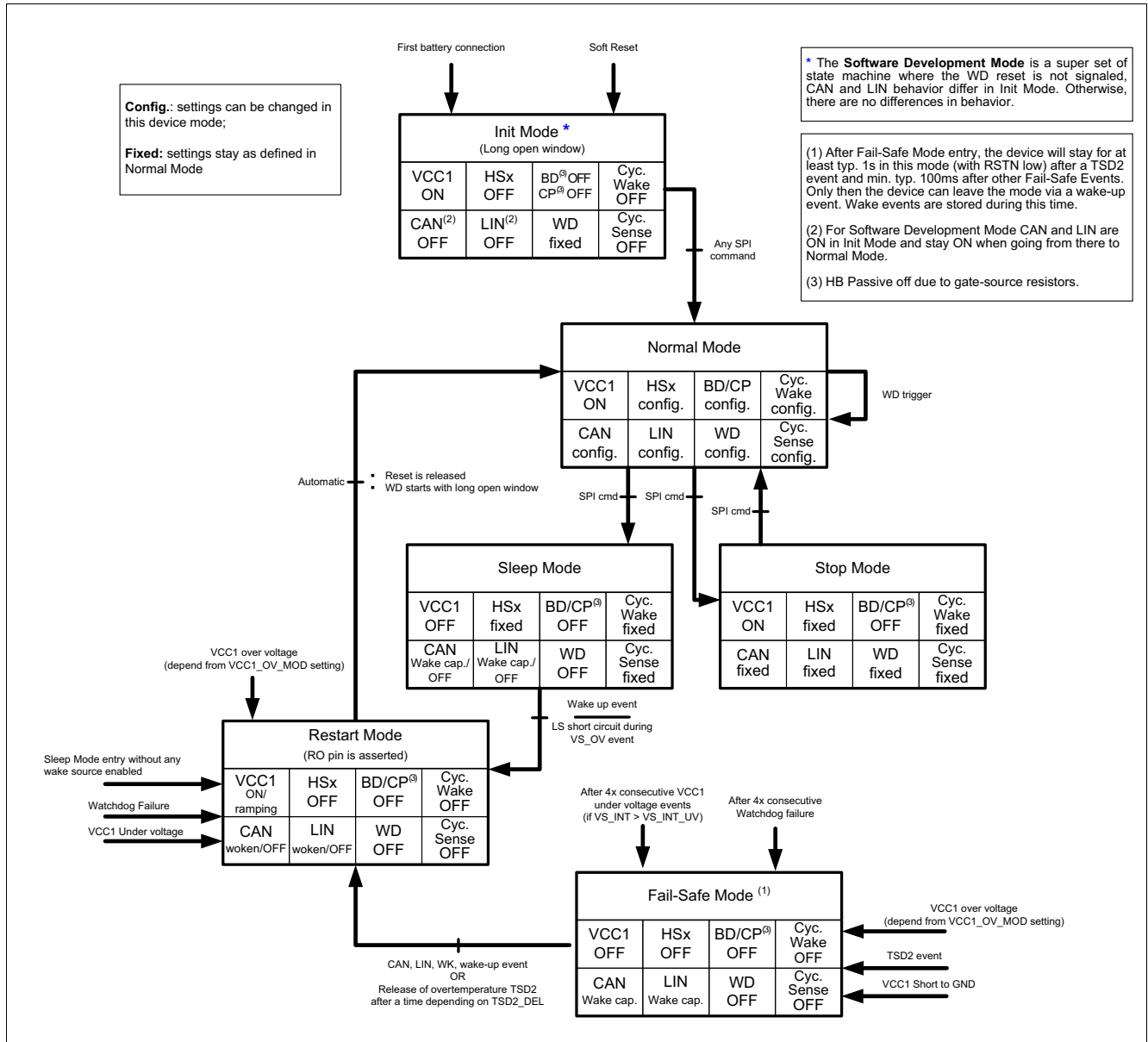

Figure 5 State Diagram showing the operating modes

Description:

- ON /OFF:= Indicate if the module is enabled or disabled either via SPI or from the device itself
- config:= Settings can be changed in this mode
- fixed:= Settings stay as defined in Normal Mode or Init Mode
- active/inactive:= Indicate if the device activates/deactivates one specific feature
- Wake capable:= Transceiver that is capable to detect one wake-up events
- woken:= Transceiver that has detected one wake-up event

System Features

5.4 State Machine Modes Description

5.4.1 Init Mode

The device starts up in Init Mode after crossing the power-on reset $V_{POR,r}$ threshold (see also [Chapter 13.3](#)) and the watchdog will start with a long open window (t_{LW}) after RSTN is released (High level).

In Init Mode, the device waits for the microcontroller to finish its startup and initialization sequence.

Init Mode (Long open window)			
VCC1 ON	HSx OFF	BD OFF CP OFF	Cyc. Wake OFF
CAN OFF	LIN OFF	WD fixed	Cyc. Sense OFF

Figure 6 Init Mode

Table 5 Init Mode Settings

Part/Function	Value	Description
VCC1	ON	• The VCC1 is ON
WD	fixed	• Watchdog is fixed and set with a long open window (t_{LW})
HSx	OFF	• All HSx are OFF
BD	OFF	• Bridge Drivers is OFF
CP	OFF	• Charge Pump is OFF
CAN	OFF	• CAN transceiver is OFF ¹⁾
LIN	OFF	• LIN transceiver is OFF ²⁾
Cyc Sense	OFF	• Cycle Sense is OFF
Cyc Wake	OFF	• Cycle Wake is OFF

1) Exception: The CAN transceiver is ON during Software Development Mode

2) Exception: The LIN transceiver is ON during Software Development Mode

5.4.2 Normal Mode

The Normal Mode is the standard operating mode for the device. The VCC1 is active and all features are configurable. Supervision and monitoring features are enabled.

System Features

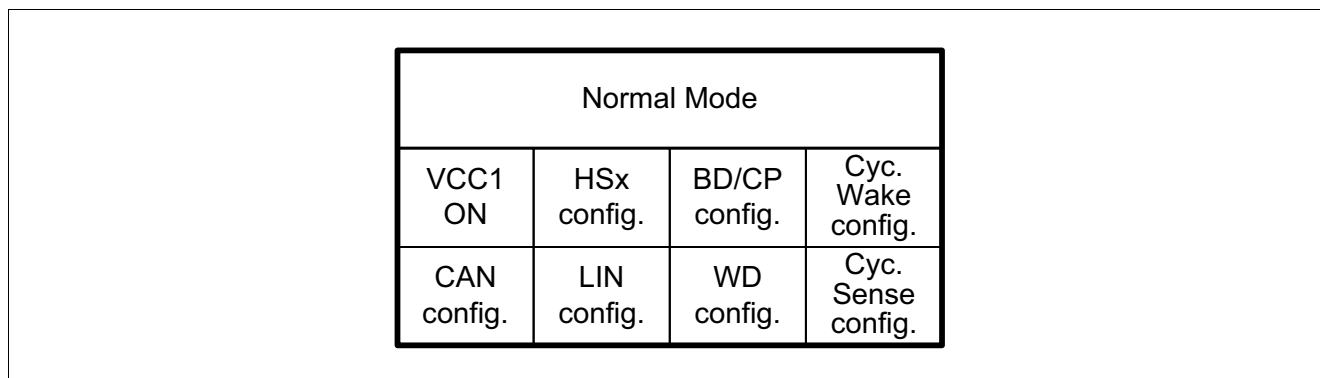

Figure 7 Normal Mode

Table 6 Normal Mode Settings

Part/Function	Value	Description
VCC1	ON	<ul style="list-style-type: none"> VCC1 is active
WD	config	<ul style="list-style-type: none"> Watchdog may be configured by SPI
HSx	config	<ul style="list-style-type: none"> The High Side Switches may be configured and switched ON or OFF by SPI
BD/CP	config	<ul style="list-style-type: none"> The Bridge Drivers and Charge Pump may be configured and switched ON or OFF by SPI
CAN	config	<ul style="list-style-type: none"> CAN may be configurable and switched ON or OFF by SPI
LIN	config	<ul style="list-style-type: none"> LIN may be configurable and switched ON or OFF by SPI
Cyc. Sense	config	<ul style="list-style-type: none"> Cyclic sense may be configured with the HSx, WKx inputs and Timer1 or Timer2 or SYNC (WK4)
Cyc. Wake	config	<ul style="list-style-type: none"> Cyclic wake can be configured with the Timer1 or Timer 2

5.4.3 Stop Mode

The Stop Mode is the first level technique to reduce the overall current consumption by setting the voltage regulator VCC1 into a low-power mode.

Note: All settings have to be done before entering Stop Mode.

In Stop Mode any kind of SPI WRITE commands are ignored and the **SPI_FAIL** bit is set, except for changing to Normal Mode, triggering a device Soft Reset, refreshing the watchdog as well as for reading and clearing the SPI status registers.

Note: A wake-up event on CAN, LIN, WKx, Low-Side short circuit detection in parking braking mode or overvoltage brake detection, could generate an interrupt on pin INTN (based on INTN masking configuration; refer to [Chapter 11](#)) however, no change of the device mode will occur.

System Features

Stop Mode			
VCC1 ON	HSx fixed	BD/CP OFF	Cyc. Wake fixed
CAN fixed	LIN fixed	WD fixed	Cyc. Sense fixed

Figure 8 Stop Mode

Table 7 Stop Mode Settings

Part/Function	Value	Description
VCC1	ON	• VCC1 is ON
WD	fixed	• Watchdog is fixed as configured in Normal Mode
HSx	fixed	• HSx are fixed as configured in Normal Mode
BD/CP	OFF	• The Bridge Drivers and Charge Pump are OFF
CAN	fixed	• CAN fixed as configured in Normal Mode
LIN	fixed	• LIN fixed as configured in Normal Mode
Cyc. Sense	fixed	• Cyclic sense fixed as configured in Normal Mode
Cyc. Wake	fixed	• Cyclic wake is fixed as configured in Normal Mode

Note: In Stop Mode, it is possible to activate the Low-Side of Bridge Drivers (e.g. in case of parking braking mode or overvoltage brake detection). Refer to [Chapter 13.11](#) for additional details.

5.4.4 Sleep Mode

The Sleep Mode is the second level technique to reduce the overall current consumption to a minimum needed to react on wake-up events or for the device to perform autonomous actions (e.g. cyclic sense).

Note: All settings have to be done before entering Sleep Mode.

Sleep Mode			
VCC1 OFF	HSx fixed	BD/CP OFF	Cyc. Wake fixed
CAN Wake cap./ OFF	LIN Wake cap./ OFF	WD OFF	Cyc. Sense fixed

Figure 9 Sleep Mode

System Features

Table 8 Sleep Mode Settings

Part/Function	Value	Description
VCC1	OFF	• VCC1 is OFF
WD	OFF	• Watchdog is OFF
HSx	fixed	• HSx are fixed as configured in Normal Mode
BD/CP	OFF	• The Bridge Drivers and Charge Pump are OFF
CAN	Wake Cap/ OFF	• CAN fixed as configured (Wake Capable or OFF)
LIN	Wake Cap/ OFF	• LIN fixed as configured (Wake Capable or OFF)
Cyc. Sense	fixed	• Cyclic sense fixed as configured in Normal Mode
Cyc. Wake	fixed	• Cyclic wake is fixed

Note: In Sleep Mode, it is possible to activate the Low-Side's of Bridge Drivers (e.g. in case of parking braking mode or overvoltage braking). Refer to [Chapter 13.11](#) for additional details.

5.4.5 Restart Mode

The Restart Mode is a transition state where the RSNT pin is asserted.

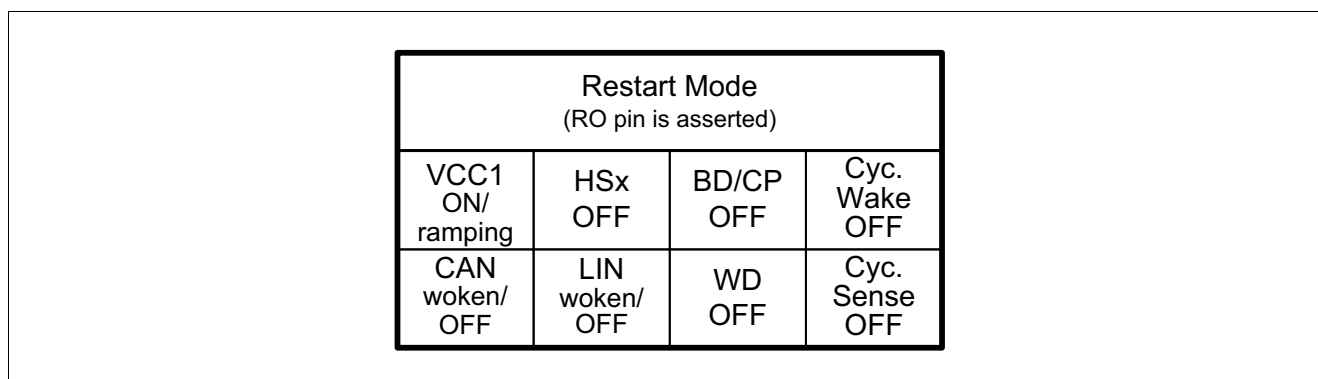

Figure 10 Restart Mode

Table 9 Restart Mode Settings

Part/Function	Value	Description
VCC1	ON/ ramping	• VCC1 is ON or ramping up
WD	OFF	• WD will be disabled if it was activated before
HSx	OFF	• HSx will be disabled if it was activated before
BD/CP	OFF	• The Bridge Drivers and Charge Pump are OFF
CAN	Woken/ wake capable/ OFF	• CAN may woken (in case of wake-up event on the Bus) or wake capable or OFF

System Features

Table 9 Restart Mode Settings (cont'd)

Part/Function	Value	Description
LIN	Woken/ wake capable/ OFF	<ul style="list-style-type: none"> LIN may woken (in case of wake-up event on the Bus) or wake capable or OFF
Cyc. Sense	OFF	<ul style="list-style-type: none"> Cyclic sense will be disabled if it was activated before
Cyc. Wake	OFF	<ul style="list-style-type: none"> Cyclic wake will be disabled if it was activated before

5.4.6 Fail-Safe Mode

The purpose of this mode is to bring the system in a safe status after a failure condition by turning OFF the VCC1 supply and powering off the microcontroller. After a wake event the system is then able to restart again.

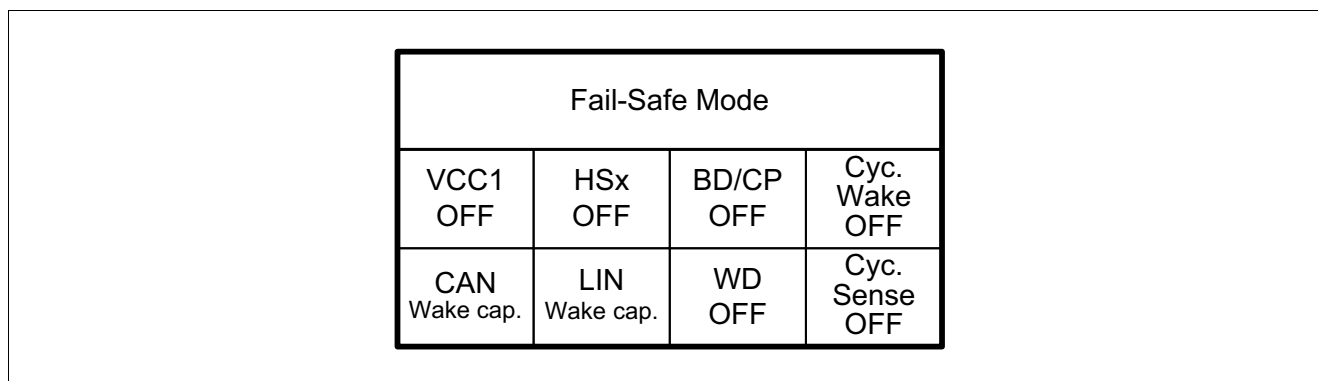

Figure 11 Fail-Safe Mode

Table 10 Fail-Safe Mode Settings

Part/Function	Value	Description
VCC1	OFF	<ul style="list-style-type: none"> VCC1 is switched OFF
WD	OFF	<ul style="list-style-type: none"> WD is switched OFF
HSx	OFF	<ul style="list-style-type: none"> HSx are switched OFF
BD/CP	OFF	<ul style="list-style-type: none"> The Bridge Drivers and Charge Pump are OFF
CAN	Wake Cap	<ul style="list-style-type: none"> CAN is forced to be Wake capable
LIN	Wake Cap	<ul style="list-style-type: none"> LIN is forced to be Wake capable
Cyc. Sense	OFF	<ul style="list-style-type: none"> Cyclic sense is switched OFF
Cyc. Wake	OFF	<ul style="list-style-type: none"> Cyclic wake is switched OFF

Note

- In Fail-Safe Mode, the default wake sources CAN, LIN and WKx (if configured as wake inputs) are activated automatically and all wake event bits will be cleared.
- In case that WK2 is set as Fail Safe Output (FO), the WK2/FO is automatically activated.
- The Fail-Safe Mode will be maintained until a wake event on the default wake sources occurs. To avoid any fast toggling behavior a filter time of typ. 100ms ($t_{FS,min}$) is implemented. Wake events during this time will be stored and will automatically lead to entering Restart Mode after the filter time.
In case of an VCC1 overtemperature shutdown (TSD2) the Restart Mode will be reached automatically after

System Features

a filter time of typ. 1s (t_{TSD2}) without the need of a wake event once the device temperature has fallen below the TSD2 threshold.

- The parking braking mode is automatically disabled in Fail-Safe Mode.

5.4.7 Software Development Mode

The Software Development Mode is a dedicated device configuration especially useful for software development.

Compared to the default device user mode operation, this mode is a super set of the state machine. The device will start also in Init Mode and it is possible to use all the modes and functions with following differences:

- Restart Mode or Fail-Safe Mode (depending on the configuration) is not reached due to watchdog failure but the other reasons to enter these modes are still valid.
- CAN, LIN default value in Init Mode and entering Normal Mode from Init Mode is ON instead of OFF.

Table 11 Normal Mode Settings (Software Development Mode active)

Part/Function	Default State	Description
VCC1	ON	• VCC1 is active
WD	ON	• WD is on, but will not trigger transition to Fail-Safe Mode or Restart Mode
HSx	OFF	• The High Side Switches may be configured and switched ON or OFF by SPI
BD/CP	OFF	• The Bridge Drivers and Charge Pump may be configured and switched ON or OFF by SPI
CAN	ON	• CAN may be configurable and switched ON or OFF by SPI
LIN	ON	• LIN may be configurable and switched ON or OFF by SPI
Cyc. Sense	OFF	• Can be configured
Cyc. Wake	OFF	• Can be configured

Software Development Mode entry

For timing and configuration details, refer to [Chapter 5.2](#).

Note

- After Init Mode, the pull-up is released as the INTN/TEST pin acts as output then to drive the INTN signal.
- If the device enters Fail-Safe Mode due to VCC1 short circuit to GND during the Init Mode, the Software Development Mode will not be entered and can only be reached at the next power-up of the device after the VCC1 short circuit is removed.
- The absolute maximum ratings of the pin INTN must be observed. To increase the robustness of this pin during debugging or programming a series resistor between INTN and the connector can be added.

Watchdog in Software Development Mode

The Watchdog is enabled in Software Development Mode as default state. One INTN event is generated due to wrong watchdog trigger.

It is possible to deactivate the integrated Watchdog module using the **WD_SDM_DISABLE** bit. After disabling the Watchdog, no INTN events are generated and the **WD_FAIL** bit will also not be set anymore in case of a trigger failure. It is also possible only to mask / unmask the INTN event of the WD in Software Development Mode by using the bit **WD_SDM**. In case of unmasking, a WD trigger fail will only lead to **WD_FAIL** bit set.

System Features

5.5 Transition Between States

This chapter describes the transition between the modes triggered by power-up, SPI commands or wake-up events.

5.5.1 Transition into Init Mode

The device goes into Init Mode in case of a power-up or after sending a soft-reset in Normal or Stop Mode.

Prerequisites:

- Power OFF
- Device in Normal Mode or Stop Mode with follow conditions:
 - $VSINT > VPOR,r$
 - RSTN High

Triggering Events:

- A Soft Reset command (**MODE** = '11'). All SPI registers will be changed to their respective Soft Reset values.

Note

- In case of Soft Reset command, a hardware RSTN event can be generated depending on the configuration. An external Reset will be generated in case of **SOFT_RESET_RO** = 0_B. In case of **SOFT_RESET_RO** = 1_B, no RSTN hardware event is generated in case of Soft Reset.
- At power-up, the SPI bit **VCC1_UV** will not be set as long as VCC1 is below the VRT,x threshold and if VSINT is below the VSINT,UV threshold. The RSTN pin will be kept LOW as long as VCC1 is below the selected VRT1,r threshold. The reset delay counter will start after VRT1,r threshold is reached. After the first threshold crossing of $VCC1 > V_{RT1,R}$ and RSTN transition from low to high, all subsequent undervoltage events will lead to Restart Mode.
- Wake events are ignored during Init Mode and will be lost.
- The bit **VSINT_UV** will only be updated in Init Mode once RSTN resumes a high level.

5.5.2 Init Mode -> Normal Mode

This transition moves the device in the mode where all configurations are accessible via SPI command.

Prerequisites:

- $VSINT > VPOR,r$
- Init Mode
- RSTN High

Triggering Events:

- Any valid SPI command (from SPI protocol point of view) will bring the device to Normal Mode (i.e. any register can be written, cleared and read) during the long open window where the watchdog has to be triggered (refer also [Chapter 14.2](#)). The CRC is not taken into account for this transition.
- For example:
 - A SPI Sleep Mode command will still bring the device into Normal Mode. However, as this is an invalid state transition, the SPI bit **SPI_FAIL** is set.
 - Any invalid SPI command (from content point of view) will still bring the device into Normal Mode. The SPI bit **SPI_FAIL** is set.

Note

- It is recommended to use the first SPI command to trigger and to configure the watchdog.

System Features

5.5.3 Normal Mode -> Stop Mode

This transition is intended as first measure to reduce the current consumption. All the device features needed in Stop Mode shall be configured in Normal Mode.

Prerequisites:

- VCC1>V_{rtx}
- Device in Normal Mode

Triggering Events:

- State transition is only initiated by specific SPI command.

Note

- An interrupt is triggered on the pin INTN when Stop Mode is entered and not all wake source signalization flags were cleared.
- If high-side switches are kept enabled during Stop Mode, then the device current consumption will increase.
- It is not possible to switch directly from Stop Mode to Sleep Mode. Doing so will also set the **SPI_FAIL** flag and will bring the device into Restart Mode.

5.5.4 Normal Mode -> Sleep Mode

This transition is intended to reduce as much as possible the current consumption keeping active only wake-up sources. All wake-up sources configurations shall be done in Normal Mode.

Prerequisites:

- VCC1>V_{rtx}
- Device in Normal Mode
- All wake source signalization flags were cleared (including the LSxDSOV_BRK bit)
- At least one wake-up source activated

Triggering Events:

- State transition is only initiated by specific SPI command.

Note

- If the HSx outputs are kept enabled during Sleep Mode, then the device current consumption will increase (see [Chapter 4.4](#)).
- The Cyclic Sense function will not work properly anymore in case of a failure event (e.g. overcurrent, over temperature, reset) because the configured HSx and Timers will be disabled.
- If **VCC1_UV** or **VCC1_OV** (with Config to go to Restart Mode) occurs at the border of the Sleep Mode entry: The device will go immediately into Restart Mode.
- If **TSD2** or **VCC1_OV** (with Config to go to Fail-Safe Mode) occurs at the border of the Sleep Mode entry: The device will enter immediately Fail-Safe Mode.
- As soon as the Sleep Mode command is sent, the Reset will go low.
- It is not possible to switch all wake sources off in Sleep Mode. Doing so will set the **SPI_FAIL** flag and will bring the device into Restart Mode.

System Features

5.5.5 Stop Mode -> Normal Mode

This transition is intended to set the device in Normal Mode where all the device integrated features are available and configurable.

Prerequisites:

- VCC1 > V_{rtx}
- Device in Stop Mode

Triggering Events:

- State transition is only initiated by SPI command.

Note

- None

5.5.6 Sleep Mode -> Restart Mode

This transition is the consequence of a detection of wake-up event by the device. This transition is used to ramp up VCC1 after a wake in a defined way.

Prerequisites:

- Device in Sleep Mode
- At least one wake-up source active

Triggering Events:

- A wake-up event on CAN, LIN, WK_x, Cyclic Sense, Cyclic Wake.
- Bridge driver low-side short circuit detected during overvoltage braking or in parking braking mode.

Note

- It is not possible to switch off all wake sources in Sleep Mode. Doing so will set the **SPI_FAIL** flag and will bring the device into Restart Mode.
- RSTN is pulled low during Restart Mode.
- The Restart Mode entry is signalled in the SPI register **DEV_STAT**.
- The wake-up events are flagged in **WK_STAT** register or **DSOV** register.

5.5.7 Restart Mode -> Normal Mode

From Restart Mode, the device goes automatically to Normal Mode.

Prerequisites:

- Device in Sleep Mode or Fail-Safe Mode

Triggering Events:

- Automatic
- Reset is released

Note

- The watchdog timer will start with a long open window starting from the moment of the rising edge of RSTN and the watchdog period setting in the register **WD_CTRL** will be changed to the respective default value.

System Features

5.5.8 Fail-Safe Mode -> Restart Mode

This transition is similar to device from Sleep Mode to Restart Mode and consequence of a detection of wake-up event by the device. This transition is used to ramp up VCC1 after a wake in a defined way.

Prerequisites:

- Device in Fail-Safe Mode

Triggering Events:

- A wake-up event on CAN, LIN, WKx, TSD2 (released over temperature TSD2 after t_{TSD2}).
- Bridge Driver Low Side short circuit detected during VS/VSINT overvoltage braking mode or in parking braking mode.

Note: After leaving Fail-Safe Mode, the **FAILURE** bit in **DEV_STAT** register is set and needs to be cleared in order to release the FO pin.

5.6 Reaction on Detected Faults

The device can react at some critical events either signalling the specific failure or changing the device mode. The chapter describes actions taken from the device in case of critical events in particular related the device mode change.

5.6.1 Stay in Current State

The following failures will not trigger any device mode changes, but will indicate the failures by an INTN event (depending from the Interrupt Masking) and in dedicated status registers:

- Failures on CAN
- Failures on LIN
- Failures in Bridge Driver and/or Charge Pump
- Failures on HSx

5.6.2 Transition into Restart Mode

The Restart Mode can be entered in case of failure as shown in following figure.

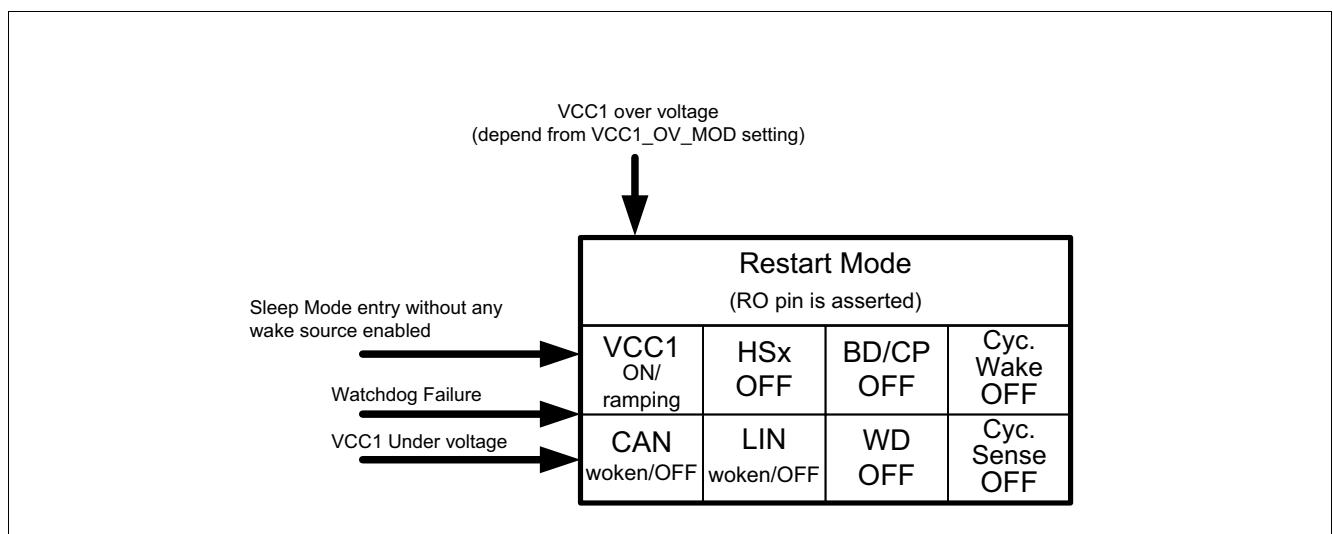

Figure 12 Move into Restart Mode

System Features

Prerequisites

- In case of wake-up event from Sleep Mode or Fail Safe Mode
- In case of Normal Mode
- In case of Stop Mode

Trigger Events

- VCC1 Undervoltage in case of Normal Mode or Stop Mode.
- Watchdog trigger failure in case of Normal Mode or Stop Mode.
- VCC1 Overvoltage (based on **VCC1_OV_MOD**) in case of Normal Mode or Stop Mode.
- Sleep Mode entry without any wake-up sources enabled in Normal Mode or Stop Mode.

Note

- None

System Features

5.6.3 Transition into Fail-Safe Mode

The Fail-Safe Mode can be entered in case of critical event as shown in the following figure.

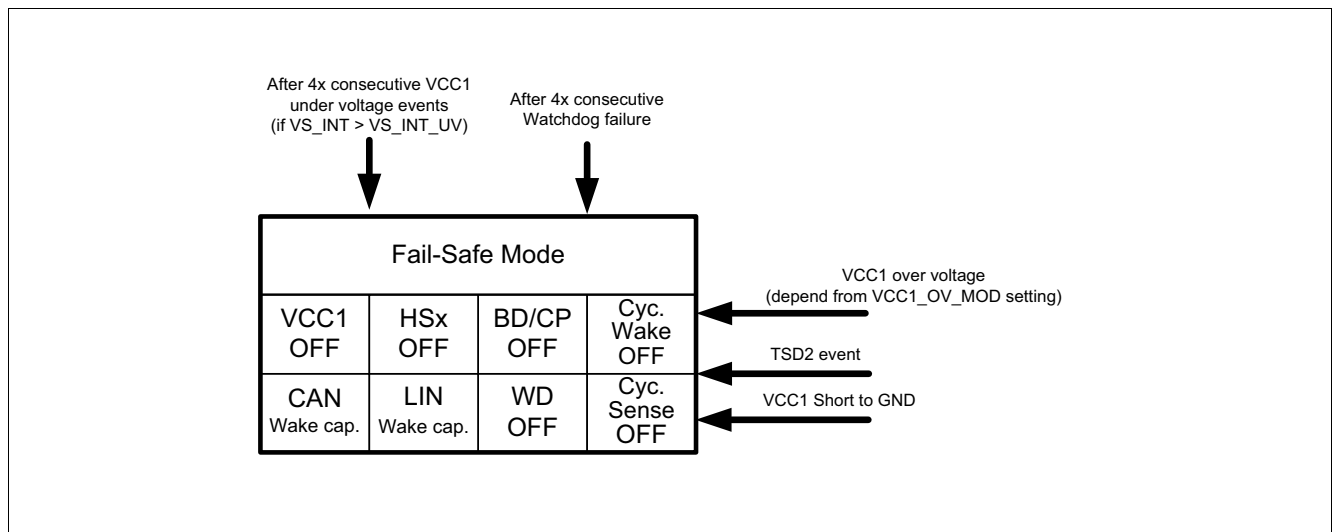

Figure 13 Move into Fail-Safe Mode

Prerequisites:

- Critical events on VCC1
- Watchdog trigger failures

Trigger Events:

- Device thermal shutdown (TSD2) (see also [Chapter 13.10.3](#)).
- VCC1 is shorted to GND (see also [Chapter 13.8](#)).
- VCC1 over voltage (based on [VCC1_OV_MOD](#)).
- 4 consecutive Watchdog trigger failure.
- 4 consecutive VCC1 under voltage events.

Note

- The FO/WK2 will be automatically activated if it was before configured as Fail Safe Output (FO).

5.7 Wake Features

Following wake sources are implemented in the device:

- Static Sense: WKx inputs are permanently active as wake sources.
- Cyclic Sense: WKx inputs only active during on-time of cyclic sense period. Internal timers are activating HSx during on-time for sensing the WKx inputs.
- Cyclic Wake: wake controlled by internal timers, wake inputs are not used for cyclic wake.
- CAN wake: Wake-up via Bus pattern or frame (refer to [Chapter 8.2.4](#) and [Chapter 5.9](#)).
- LIN wake: Wake-up via Bus messages (refer to [Chapter 9.2.4](#)).

*Note: Differences of 'cyclic sense' and 'cyclic wake':
In both cases a timer is active. With 'cyclic sense' one of the high-side drivers is switched on periodically and supplies some external circuits connected to the WK inputs. For the design, this means that the WK input states are only sampled at the end of the selected HS on-phase which is set*

System Features

by the corresponding SPI settings for GPIO HS and the timer. 'Cyclic wake' means that the timer is a wake source and thus generates periodic interrupts as long as it is enabled.

5.7.1 Cyclic Sense

The cyclic sense feature is intended to reduce the quiescent current of the device and the application. In the cyclic sense configuration, one high-side driver is switched on periodically controlled by **TIMER_CTRL** or WK4/SYNC pin. One high-side driver supplies external circuitries e.g. switches and/or resistor arrays, which are connected to one wake input WKx (see **Figure 14**). Any edge change of the WKx input signal during the on-time of the cyclic sense period causes a wake event. Depending on the device mode, either the INTN is pulled low (Normal Mode and Stop Mode) or the device is woken enabling the VCC1 (after Sleep Mode).

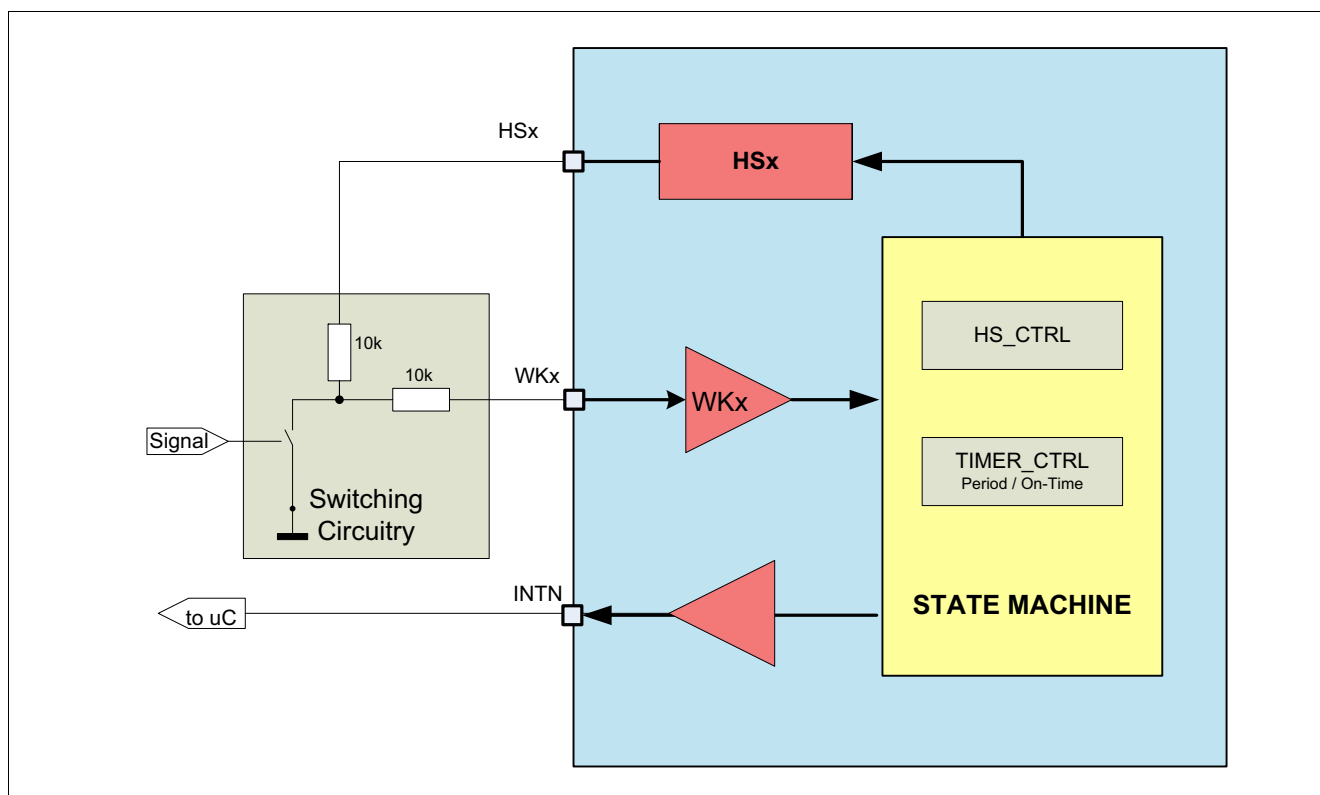

Figure 14 Cyclic Sense Working Principle

5.7.1.1 Configuration and Operation of Cyclic Sense

The correct sequence to configure the cyclic sense is shown in **Figure 15**. All the configurations have to be performed before the on-time is set in the **TIMER_CTRL** registers. The settings "OFF / LOW" and "OFF / HIGH" define the voltage level of the respective HS driver before the start of the cyclic sense. The intention of this selection is to avoid an unintentional wake due to a voltage level change at the start of the cyclic sense.

Cyclic Sense will start as soon as the respective on-time has been selected independently from the assignment of the HS and filter configuration. The correct configuration sequence is as follows:

- Configure the initial level.
- Mapping of a Timer to the respective HSx outputs.
- Configuring the respective filter timing and WK pins.
- Configuring the timer period and on-time.

System Features

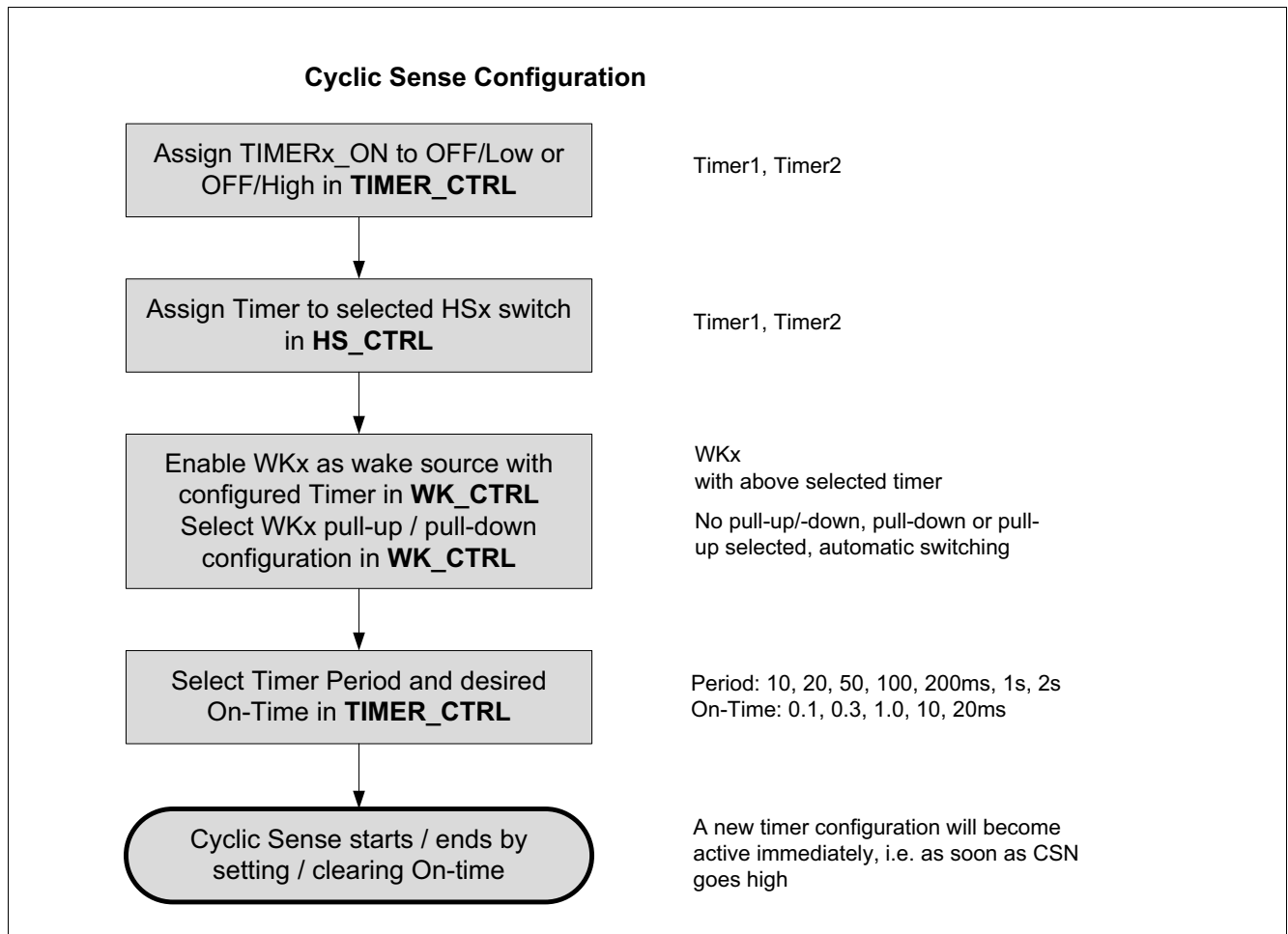

Figure 15 Cyclic Sense: Configuration and Sequence

System Features

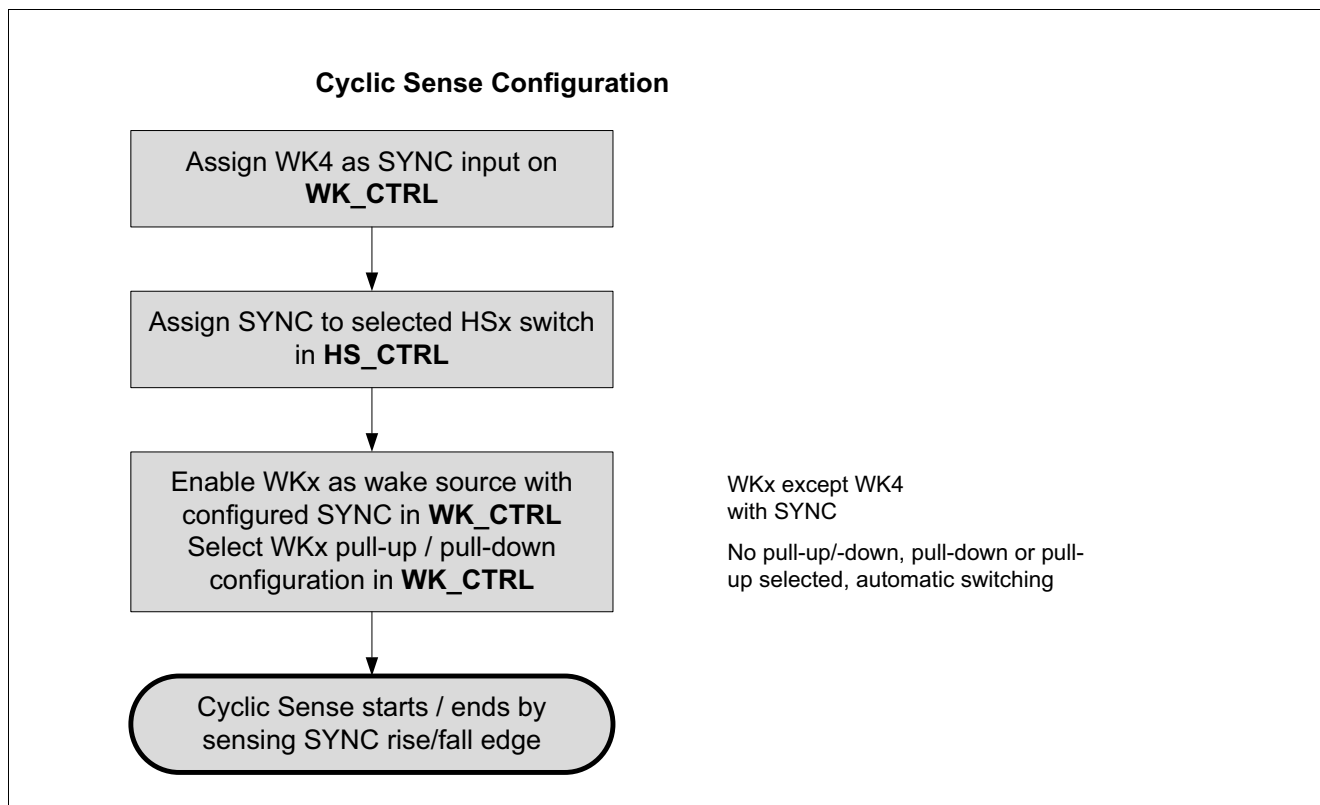

Figure 16 Cyclic Sense: Configuration and Sequence in case of SYNC usage

Note

- All configurations of period and on-time can be selected. However, recommended on-times for cyclic sense are 0.1ms, 0.3ms and 1ms for quiescent current saving reasons. The **SPI_FAIL** will be set if the on-time is longer than the period.
- If the sequence is not ensured before entering Sleep Mode, then the cyclic sense function might not work properly, e.g. an interrupt could be missed or an unintentional interrupt could be triggered. However, if cyclic sense is the only wake source and it is not configured properly, then Restart Mode will be entered immediately because no valid wake source was set.
- During the HSx on phase in cyclic-sensing, the WKx level is sampled only once (one sample point). In case, a level change will appear during HSx on phase, but before the sampling, as the sampling will happen at the end of the on time, the level change will not be detected and has to wait for the next sensing-cycle.

A wake event caused by cyclic-sensing will also set the corresponding bit WKx_WU.

During Cyclic Sense, **WK_LVL_STAT** is updated only with the sampled voltage levels of the WKx pin in Normal Mode or Stop Mode.

The functionality of the sampling and different scenarios are depicted in **Figure 17** to **Figure 19**. The behavior in Stop Mode and Sleep Mode is identical except that in Normal Mode and Stop Mode INTN will be triggered to signal a change of WKx input level and in Sleep Mode, VCC1 will power-up instead. A wake event will be triggered regardless if the bit WKx_WU is already set.

System Features

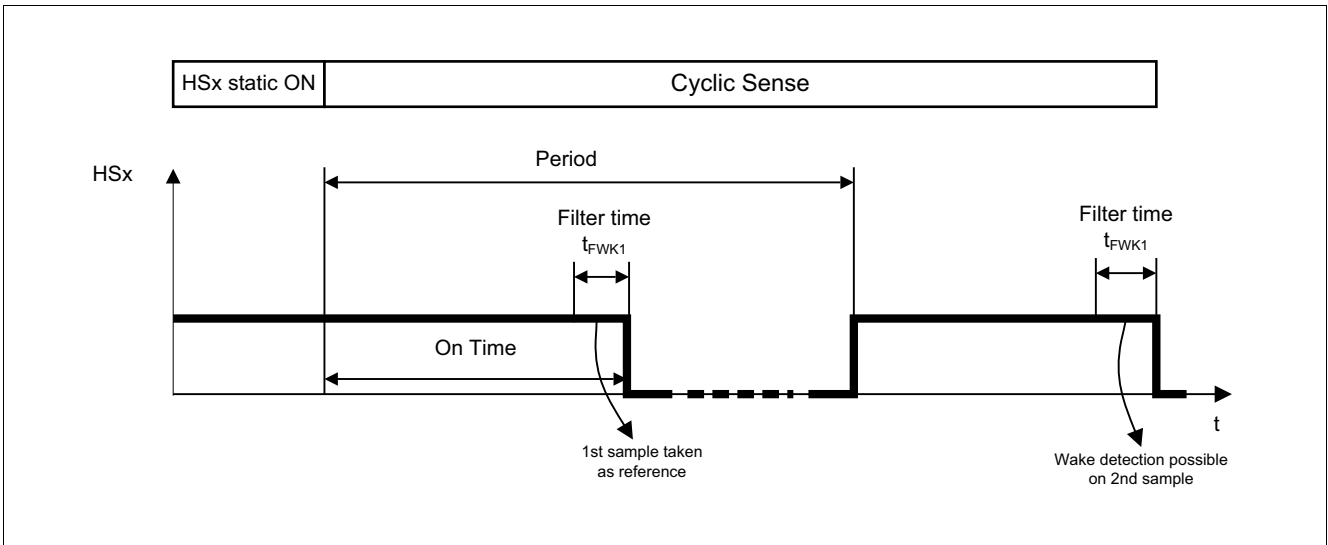

Figure 17 Cyclic Sense Timing

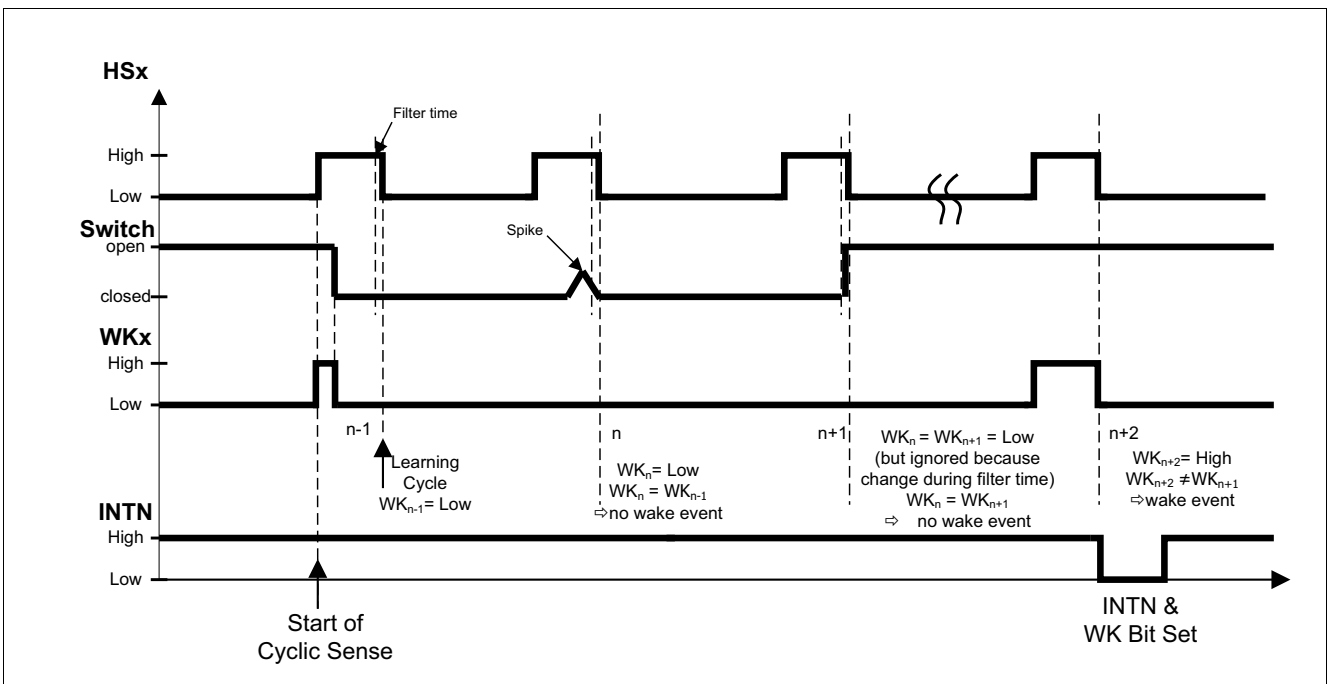

Figure 18 Cyclic Sense Example Timing for Stop Mode, HSx starts LOW, GND based WKx input

System Features

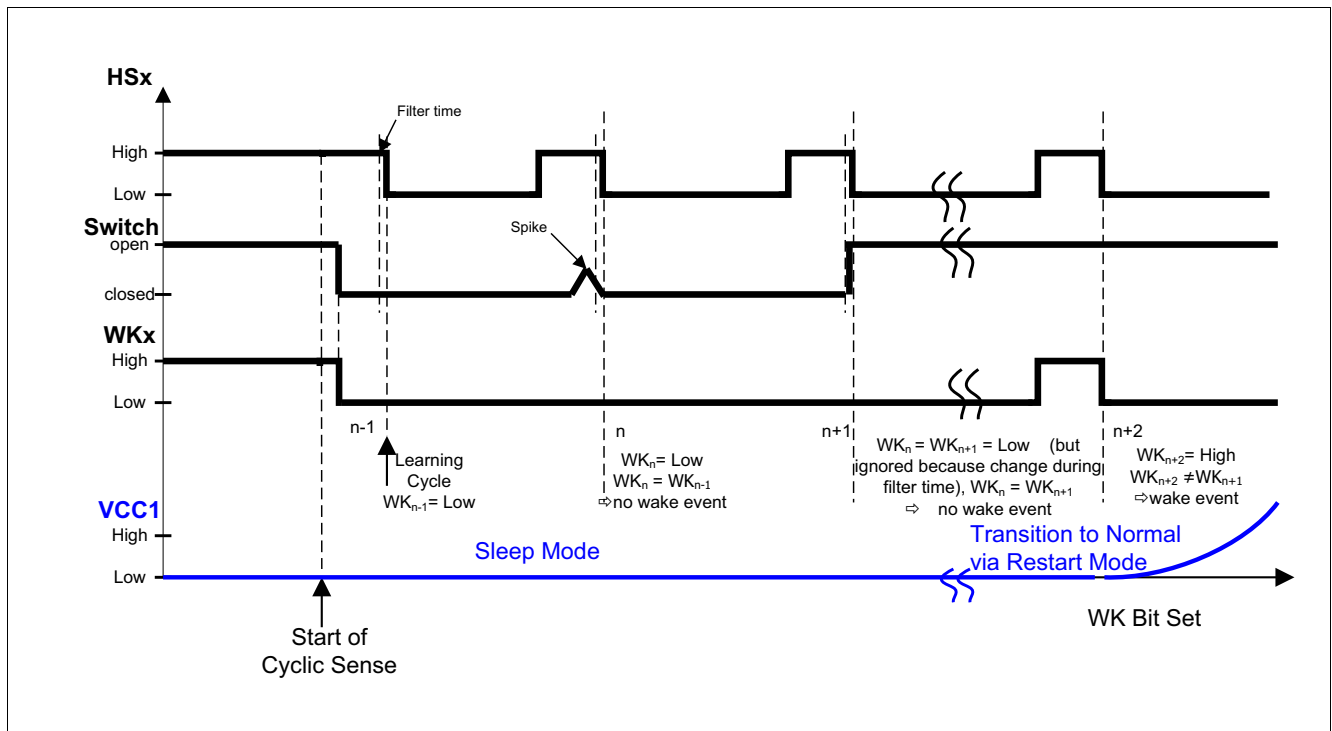

Figure 19 Cyclic Sense Example Timing for Sleep Mode, HSx starts with ON, GND based WKx input

The cyclic sense function will be disabled in case of following conditions:

- in case Fail-Safe Mode is entered, the HSx switch will be disabled and the WKx pin will be changed to static sensing. An unintended wake-up event could be triggered when the WKx input is changed to static sensing.
- In Normal Mode, Stop Mode, or Sleep Mode in case of an overcurrent, or overtemperature, or under- or overvoltage event, the respective HS switch will be disabled.

5.7.1.2 Cyclic Sense in Low-power Mode

If cyclic sense is intended for Stop Mode or Sleep Mode, it is necessary to activate cyclic sense in Normal Mode before going to the low-power mode. A wake event due to cyclic sense will set the bit WKx_WU. In Stop Mode a wake event will trigger an interrupt, in Sleep Mode the wake event will send the device via Restart Mode to Normal Mode.

Before returning to Sleep Mode, the wake status registers **WK_STAT** and **DSOV** must be cleared. Trying to go to Sleep Mode with uncleared wake flags will lead to a direct wake-up from Sleep Mode by going via Restart Mode to Normal Mode and triggering of RSTN.

5.7.2 Cyclic Wake

For the cyclic wake feature one timer is configured as internal wake-up source and will periodically trigger an interrupt on INTN in Normal Mode and Stop Mode. During Sleep Mode, the timer triggers and wakes up the device again. The device enters via Restart Mode the Normal Mode.

The correct sequence to configure the cyclic wake is shown in **Figure 20**. The sequence is as follows:

System Features

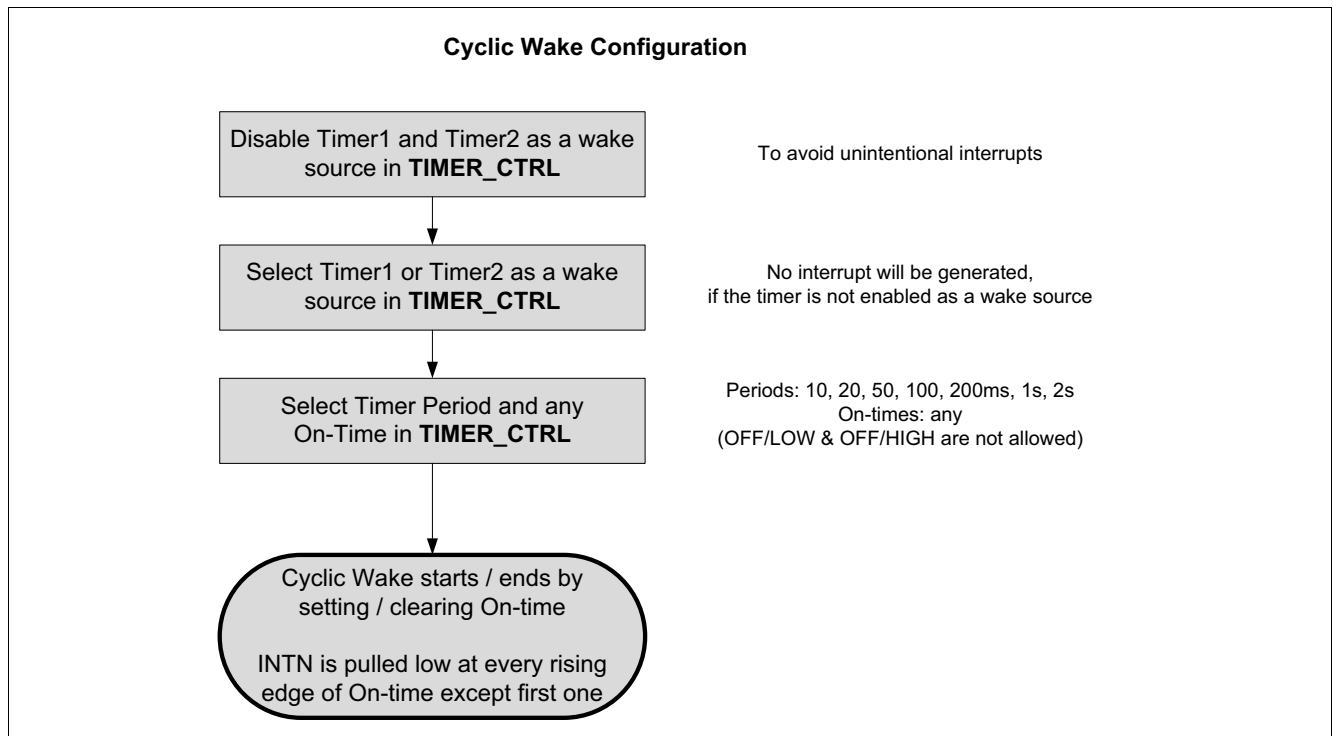

Figure 20 Cyclic Wake: Configuration and Sequence

Note: The on-time is only used to enable the cyclic wake function regardless of the value of the on time, i.e. the on time value has no meaning to the cyclic wake function as long as it is not '000' or '110' or '111'.

As in cyclic sense, the cyclic wake function will start as soon as the on-time is configured. An interrupt is generated for every start of the on-time except for the very first time when the timer is started.

5.7.3 Internal Timers

Two integrated timers can be used to control the below features:

- Cyclic Wake, i.e. to wake up the microcontroller periodically in Normal Mode, Stop Mode and Sleep Mode.
- Cyclic Sense, i.e. to perform cyclic sensing using the wake input WKx and the HSx by mapping the timer accordingly via the **HS_CTRL** register.

5.8 VS Supply Multiplexing

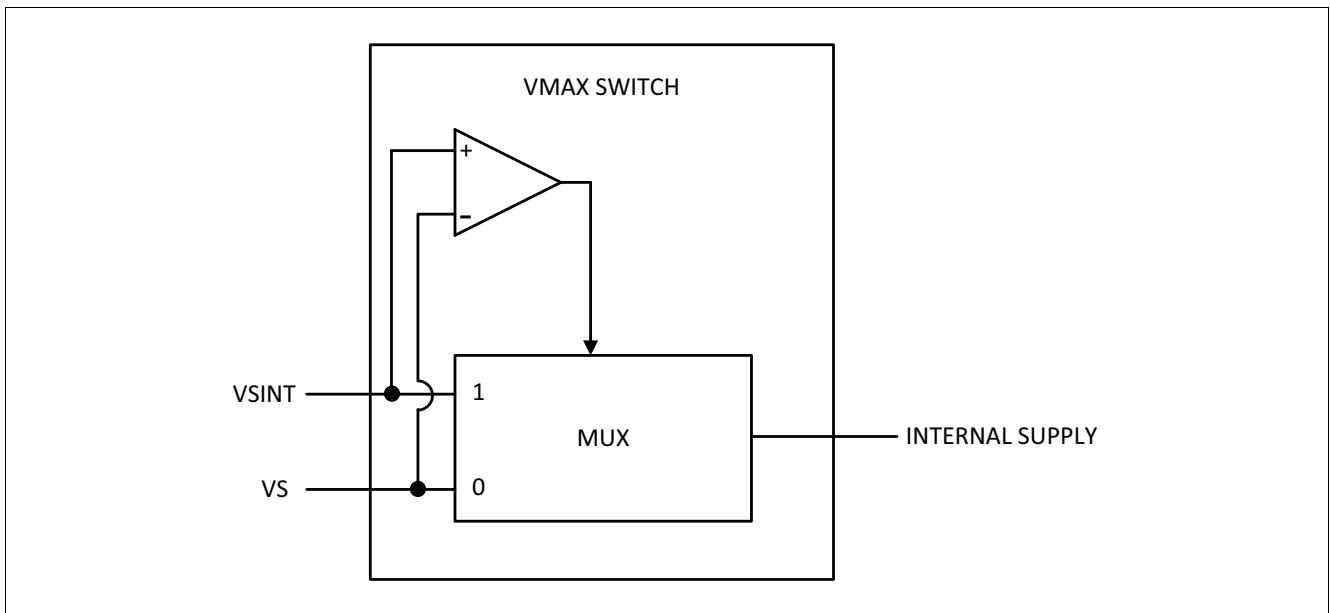

Figure 21 VS Supply Multiplexing

The internal supply voltage is multiplexed from VSINT and VS, choosing continuously the larger of both. In case of transient low VBAT, the buffered supply voltage takes over the internal supply, avoiding loss of power.

Note: Only the internal digital logic of the device is supplied by the VMAX SWITCH. In case of a power loss of either VS or VSINT, the internal register values will not be lost.

5.9 Partial Networking on CAN

5.9.1 CAN Partial Networking - Selective Wake Feature

The CAN partial networking feature can be activated for Normal Mode, in Sleep Mode and in Stop Mode. For Sleep Mode the partial networking has to be activated before sending the device to Sleep Mode. For Stop Mode the Partial Networking has to be activated before going to Stop Mode.

There are 2 detection mechanism available:

- WUP (Wake-Up Pattern) this is a CAN wake, that reacts on the CAN dominant time, with 2 dominant signals.
- WUF (Wake-Up frame) this is the wake-up on a CAN frame that matches the programmed message filter configured in the device via SPI.

The default baudrate is set to 500 kBaud. Besides the commonly used baudrates of 125 kBaud and 250 kBaud, other baudrates up to 1 MBaud can be selected (see [Chapter 14](#) for more details).

5.9.2 Partial Networking Function

The CAN partial networking modes are shown in the following figure.

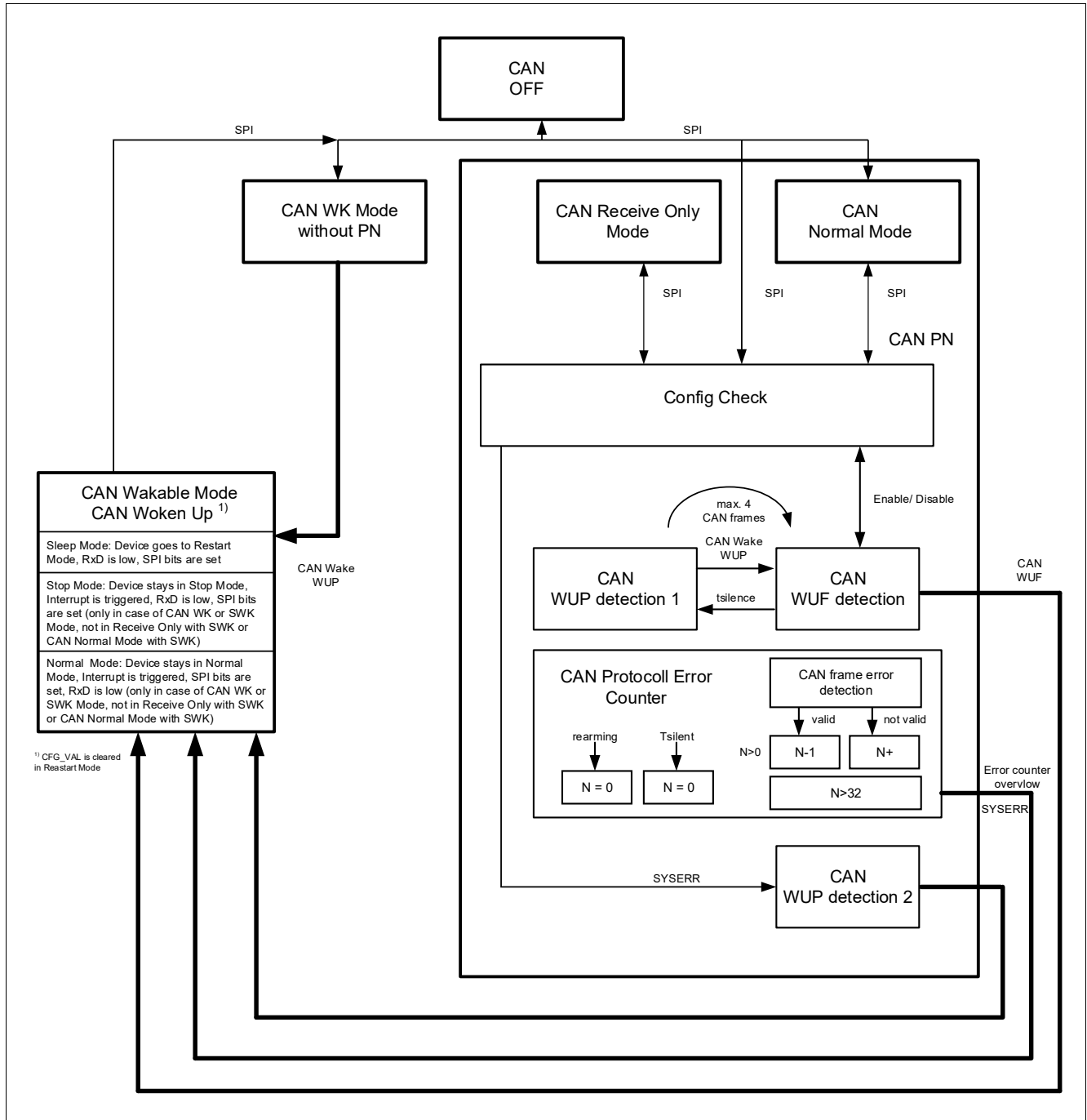

Figure 22 CAN Selective Wake State Diagram

5.9.2.1 Activation of SWK

The following figure shows the principal of the SWK activation.

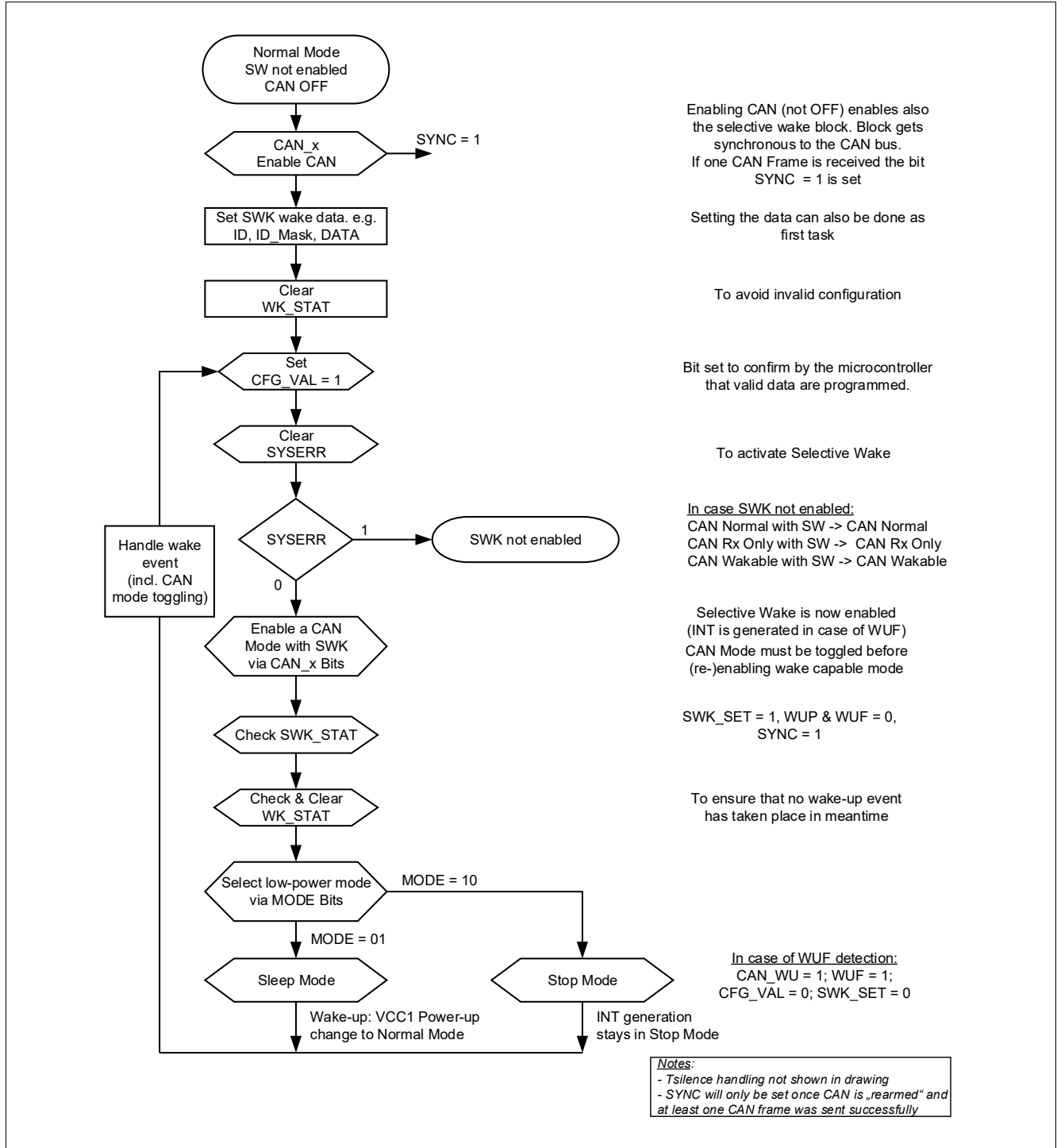

Figure 23 Flow for activation of SWK

5.9.2.2 Wake-up Pattern (WUP)

A WUP is signaled on the bus by two consecutive dominant bus levels for at least t_{WAKE1} , each separated by a recessive bus level.

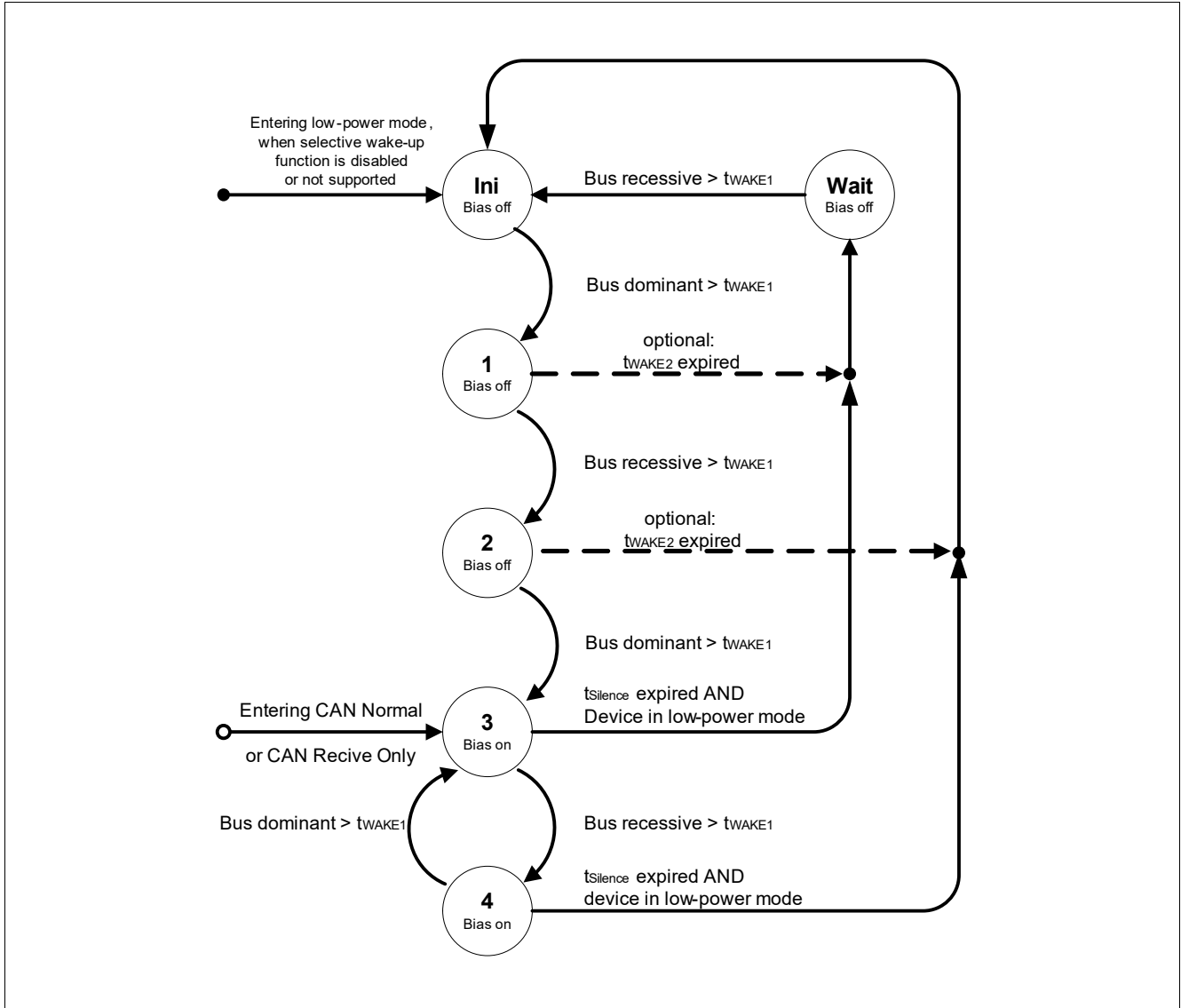

Figure 24 WUP detection following the definition in ISO11898-2:2016

5.9.2.3 Wake-up Frame (WUF)

The wake-up frame is defined in ISO11898-2:2016.

Only CAN frames according ISO11899-1 are considered as potential wake-up frames.

A bus wake-up shall be performed, if selective wake-up function is enabled and a "valid WUF" has been received. The transceiver may ignore up to four consecutive CAN data frames that start after switching on the bias.

A received frame is a "valid WUF" in case all of the following conditions are met:

- The ID of the received frame is exactly matching a configured ID in the relevant bit positions. The relevant bit positions are given by an ID mask. The ID and the ID mask might have either 11 bits or 29 bits.
- The DLC of the received frame is exactly matching the configured DLC.

- In case DLC is greater than 0, the data field of the received frame has at least one bit set in a bit position, where also in the configured data mask in the corresponding bit position the bit is set.
- No error exists according to ISO11898-2:2016 except errors which are signalled in the ACK field and EOF field.

5.9.2.4 CAN Protocol Error Counter

The counter is incremented, when a bit stuffing, CRC or form error according to ISO11898-2:2016 is detected. If a frame has been received that is valid up to the end of the CRC field and the counter is not zero, the counter is decremented.

If the counter has reached a value of 31, the following actions is performed on the next increment of this counter:

- The selective wake function is disabled.
- The CAN transceiver is woken.
- SYSERR is set and the error counter value = 32 can be read.

On each increment or decrement of the counter the decoder unit waits for at least 6 and most 10 recessive bits before considering a dominant bit as new start of frame.

The error counter is enabled:

- Whenever the CAN is in CAN Normal Mode, CAN Receive Only Mode or in WUF detection state.

The error counter is cleared under the following conditions:

- At the transition from WUF detection to WUP detection 1 (after t_{SILENCE} expiration, while SWK is correctly enabled).
- When WUF detection state is entered (in this way the counter will start from 0 when SWK is enabled).
- At CAN rearming (when exiting the woken state).
- When the CAN mode bits are selected '000', '100' (CAN off) or '0'01' (Wake capable without SWK function enabled).
- While CAN_FD_EN = '1' and DIS_ERR_CNT = '1'
(the counter is cleared and stays cleared when these two bits are set in the SPI registers).

The Error Counter is frozen:

- After a wake-up being in woken state.

The counter value can be read out of the bits **ECNT**.

5.9.3 Diagnoses Flags

5.9.3.1 PWRON/RESET-FLAG

The power-on reset can be detected and read by the **POR** bit in the Status register.
The VS power on resets all register in the device to reset value. SWK is not configured.

5.9.3.2 BUSERR-Flag

Bus Dominant Time-out detection is implemented and signaled by CAN_Fail_x in register **BUS_STAT**.

5.9.3.3 TXD Dominant Time-out flag

TXD Dominant timeout is shown in the SPI bit CAN_FAIL_x in register **BUS_STAT**.

5.9.3.4 WUP Flag

The WUP bit in the **SWK_STAT** register shows that a Wake-Up Pattern (WUP) has caused a wake of the CAN transceiver. It can also indicate an internal mode change from WUP detection 1 state to WUF detection after a valid WUP.

In the following case the bit is set:

- SWK is activated: due to t_{SILENCE} , the CAN changes into the state WUP detection 1. If a WUP is detected in this state, then the **WUP** bit is set.
- SWK is deactivated: the **WUP** bit is set if a WUP wakes up the CAN. In addition, the **CAN_WU** bit is set.
- In case WUP is detected during WUP detection 2 state (after a SYSERR) the bits **WUP** and **CAN_WU** are set.

The **WUP** bit is cleared automatically by the device at the next rearming of the CAN transceiver.

*Note: It is possible that WUF and WUP bit are set at the same time if a WUF causes a wake out of SWK, by setting the interrupt or by restart out of Sleep Mode. The reason is because the CAN has been in WUP detection 1 state during the time of CAN SWK Mode (because of t_{SILENCE}). See also **Figure 22**.*

5.9.3.5 WUF Flag (WUF)

The WUF bit in the **SWK_STAT** register shows that a Wake-Up frame (WUF) has caused a wake of the CAN block. In Sleep Mode this wake causes a transition to Restart Mode, in Normal Mode and in Stop Mode it causes an interrupt. Also in case of this wake the bit **CAN_WU** in the register **WK_STAT** is set.

The **WUF** bit is cleared automatically by the device at the next rearming of the CAN SWK function.

5.9.3.6 SYSERR Flag (SYSERR)

The bit **SYSERR** is set in case of an configuration error and in case of an error counter overflow. The bit is only updated (set to '1') if a CAN mode with SWK is enabled via CAN_x. An interrupt is triggered on INTN every time SYSERR is set if the **BUS_STAT** is not masked.

When programming selective wake via CAN_x, SYSERR = '0' signals that the SWK function has been enabled. The bit can be cleared via SPI. The bit is '0' after Power on Reset of the device.

5.9.3.7 Configuration Error

A configuration error sets the SYSERR bit to '1'. A configuration check is performed when enabling SWK via the bits CAN_x. If the check is successful SWK is enabled, the bit SYSERR is set to '0'. In Normal Mode it is also possible to detect a Configuration Error while SWK is enabled. This will occur if the **CFG_VAL** bit is cleared, e.g. by changing the SWK registers (from address 011 0001 to address 011 1010). In Stop Mode and Sleep Mode this is not possible as the SWK registers can not be changed.

Configuration Check:

In Restart Mode, the **CFG_VAL** bit is cleared by the device. If the Restart Mode was not triggered by a WUF wake up from Sleep Mode and the CAN was with SWK enabled, then the **SYSERR** bit will be set.

The SYSERR bit has to be cleared by the microcontroller.

The SYSERR bit cannot be cleared when CAN_2 is '1' and below conditions occur:

- Data valid bit not set by microcontroller, i.e. **CFG_VAL** is not set to '1'. The **CFG_VAL** bit is reset after SWK wake and needs to be set by the microcontroller before activation SWK again.
- **CFG_VAL** bit reset by the device when data are changed via SPI programming. (Only possible in Normal Mode)

Note: The SWK configuration is still valid if only the **SWK_CTRL** register is modified.

5.9.3.8 CAN Bus Timeout-Flag (**CANTO**)

In CAN WUF detection and CAN WUP detection 2 state the bit CANTO is set to '1' if the time t_{SILENCE} expires.

The bit can be cleared by the microcontroller. If the interrupt function for CANTO is enabled then an interrupt is generated in Stop Mode or Normal Mode when the CANTO set to '1'. The interrupt is enabled by setting the bit **CANTO_MASK** to '1'. Each CANTO event will trigger a interrupt even if the CANTO bit is not cleared.

There is no wake out of Sleep Mode because of CAN time-out.

5.9.3.9 CAN Bus Silence-Flag (**CANSIL**)

In CAN WUF detection and CAN WUP detection 2 state the bit CANSIL is set to '1' if the time t_{SILENCE} expires.

The CANSIL bit is set back to '0' with a WUP. With this bit the microcontroller can monitor if there is activity on the CAN bus while being in CAN SWK Mode. The bit can be read in Stop Mode and Normal Mode.

5.9.3.10 SYNC-FLAG (**SYNC**)

The bit SYNC shows that SWK is working and synchronous to the CAN bus. To get a SYNC bit set it is required to enable the CAN to CAN Normal Mode or in CAN Receive Only Mode or in WUF detection. However - for WUF detection, the CAN SWK Mode must be enabled.

The bit is set to '1' if a valid CAN frame has been received (no CRC error and no stuffing error). It is set back to '0' if a CAN protocol error is detected. When switching into CAN SWK Mode the SYNC bit indicates to the microcontroller that the frame detection is running and the next CAN frame can be detected as a WUF, CAN wake-up can now be handled by the device. It is possible to enter a low-power mode with SWK even if the bit is not set to '1', as this is necessary in case of a silent bus.

5.9.3.11 SWK_SET FLAG (**SWK_SET**)

The SWK_SET bit is set to signalize the following states (see also **Figure 22**):

- When SWK was correctly enabled in WUF Detection state.
- When SWK was correctly enabled when in WUP Detection 1 state.
- After a SYSERR before a wake event in WUP Detection 2 state.

The bit is cleared under following conditions:

- After a wake-up (ECNT overflow, WUP in WUP detection 2, WUF in WUF detection).
- If CAN_2 is cleared.

5.9.4 Modes for Selective Wake (SWK)

The device mode is selected via the **MODE** bits as described in **Chapter 5.3**.

The mode of the CAN transceiver needs to be selected in Normal Mode. The CAN mode is programmed the bits CAN_0, CAN_1 and CAN_2. In the low-power modes (Stop, Sleep) the CAN mode can not be changed via SPI.

The detailed state machine diagram including the CAN selective wake feature is shown in **Figure 5**.

The application must now distinguish between the normal CAN operation and the selective wake function:

- CAN WK Mode: This is the normal CAN wake capable mode without the selective wake function.
- CAN SWK Mode: This is the CAN wake capable mode with the selective wake function enabled.

Figure 25 shows the possible CAN transceiver modes.

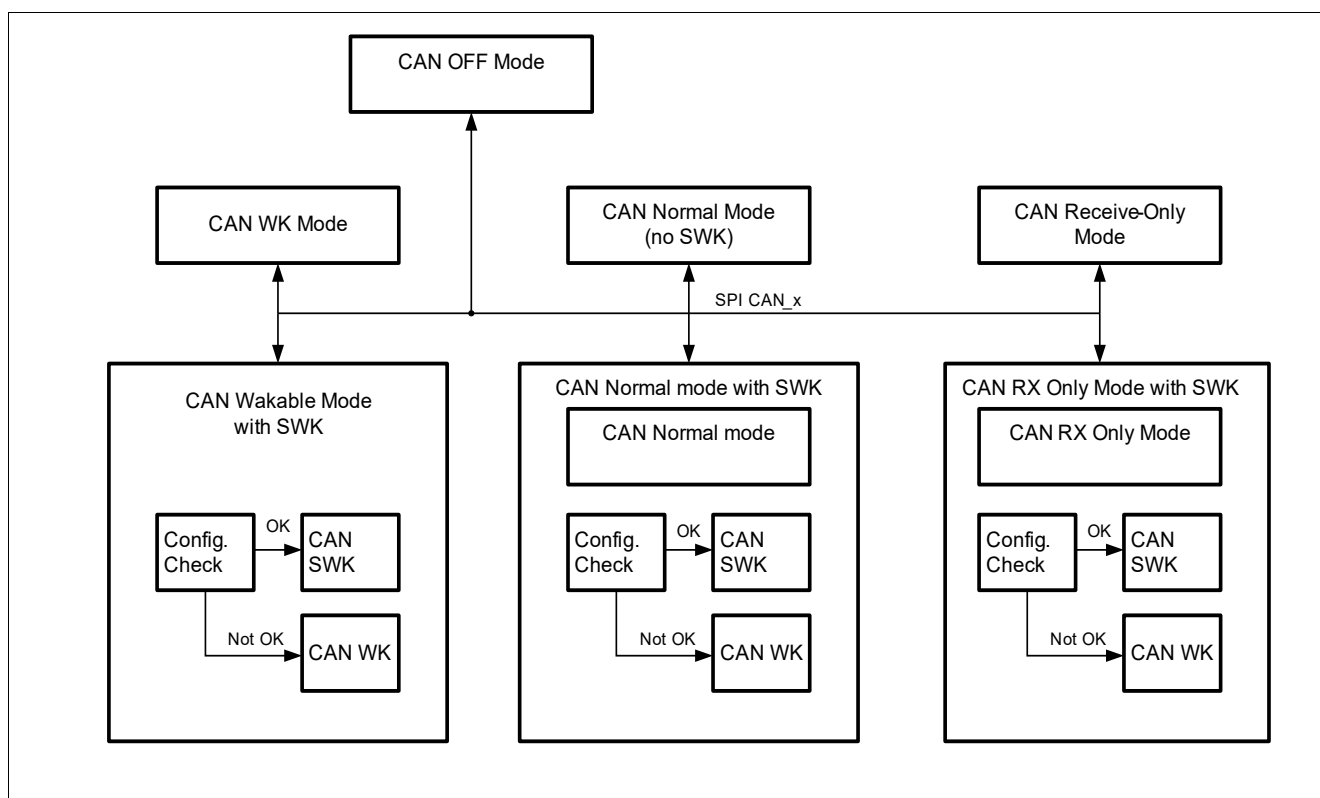

Figure 25 CAN SWK State Diagram

5.9.4.1 Normal Mode with SWK

In Normal Mode the CAN Transceiver can be switched into the following CAN modes:

- CAN OFF Mode
- CAN WK Mode (without SWK)
- CAN SWK Mode
- CAN Receive Only Mode (No SWK activated)
- CAN Receive Only Mode with SWK

- CAN Normal Mode (No SWK activated)
- CAN Normal Mode with SWK

In the CAN Normal Mode with SWK the CAN Transceiver works as in Normal Mode, so bus data is received through RXD, data is transmitted through TXD and sent to the bus. In addition the SWK block is active. It monitors the data on the CAN bus, updates the error counter and sets the **CANSIL** flag if there is no communication on the bus.

It will generate an CAN Wake interrupt in case a WUF is detected (RXD is not pulled to low in this configuration).

In CAN Receive Only Mode with SWK, CAN data can be received on RXD and SWK is active, no data can be sent to the bus.

The bit **SYSERR** = '0' indicates that the SWK function is enabled, and no frame error counter overflow is detected.

Table 12 CAN modes selected via SPI in Normal Mode

CAN mode	CAN_2	CAN_1	CAN_0
CAN OFF Mode	0	0	0
CAN WK Mode (no SWK)	0	0	1
CAN Receive Only Mode (no SWK)	0	1	0
CAN Normal Mode (no SWK)	0	1	1
CAN OFF Mode	1	0	0
CAN SWK Mode	1	0	1
CAN Receive Only Mode with SWK	1	1	0
CAN Normal Mode with SWK	1	1	1

When reading back CAN_x the programmed mode is shown in Normal Mode. To read the real CAN mode the bits **SYSERR**, **SWK_SET** and **CAN** have to be evaluated. A change out of Normal Mode can change the CAN_0 and CAN_1 bits.

5.9.4.2 Stop Mode with SWK

In Stop Mode the CAN transceiver can be operated with the following CAN modes:

- CAN OFF Mode
- CAN WK Mode (no SWK)
- CAN SWK Mode
- CAN Receive Only Mode (no SWK)
- CAN Receive Only Mode with SWK
- CAN Normal Mode (no SWK)
- CAN Normal Mode with SWK

To enable CAN SWK Mode the CAN has to be switched to “CAN Normal Mode with SWK”, “CAN Receive Only Mode with SWK” or to “CAN SWK Mode” in Normal Mode before sending the device to Stop Mode. The bit **SYSERR** = '0' indicates that the SWK function is enabled. The table shows the change of CAN mode when switching from Normal Mode to Stop Mode.

Note: CAN Receive Only Mode in Stop Mode is implemented to also enable pretended networking (Partial networking done in the microcontroller).

Table 13 CAN modes change when switching from Normal Mode to Stop Mode

Programmed CAN mode in Normal Mode	CAN_x bits	SYSERR bit	CAN mode in Stop Mode	CAN_x bits
CAN OFF Mode	000	0	CAN OFF Mode	000
CAN WK Mode (no SWK)	001	0	CAN WK Mode (no SWK)	001
CAN Receive Only Mode (no SWK)	010	0	CAN Receive Only Mode (no SWK)	010
CAN Normal Mode (no SWK)	011	0	CAN Normal Mode (no SWK)	011
CAN OFF Mode	100	0	CAN OFF Mode	100
CAN SWK Mode	101	0	CAN SWK Mode	101
CAN SWK Mode	101	1	CAN WK Mode (no SWK)	101
CAN Receive Only Mode with SWK	110	0	CAN Receive Only Mode with SWK	110
CAN Receive Only Mode with SWK	110	1	CAN Receive Only Mode (no SWK)	110
CAN Normal Mode with SWK	111	0	CAN Normal Mode with SWK	111
CAN Normal Mode with SWK	111	1	CAN Normal Mode (no SWK)	111

Note: When SYSERR is set then WUF frames will not be detected, i.e. the selective wake function is not activated (no SWK), but the MSB of CAN mode is not changed in the register.

5.9.4.3 Sleep Mode with SWK

In Sleep Mode the CAN Transceiver can be switched into the following CAN modes:

- CAN OFF Mode
- CAN WK Mode (without SWK)
- CAN SWK Mode

To enable “CAN SWK Mode” the CAN has to be switched to “CAN Normal Mode with SWK”, “CAN Receive Only Mode with SWK” or to “CAN SWK Mode” in Normal Mode before sending the device to Sleep Mode. The table shows the change of CAN mode when switching from Normal Mode to Sleep Mode.

A wake from Sleep Mode with Selective Wake (Valid WUF) leads to Restart Mode. In Restart Mode the CFG_VAL bit will be cleared by the device, the SYSERR bit is not set. In the register CAN_x the programmed CAN SWK Mode (101) can be read.

To enable the CAN SWK Mode again and to enter Sleep Mode the following sequence can be used; Program a CAN mode different from CAN SWK Mode (101, 110, 111), set the CFG_VAL, CLEAR SYSERR bit, Set CAN_x bits to CAN SWK Mode (101), switch the device to Sleep Mode.

To enable the CAN WK Mode or CAN SWK Mode again after a wake on CAN a rearming is required for the CAN transceiver to be wake capable again. The rearming is done by programming the CAN into a different mode with the CAN_x bit and back into the CAN WK Mode or CAN SWK Mode. To avoid lock-up when switching the device into Sleep Mode with an already woken CAN transceiver, the device does an automatic rearming of the CAN transceiver when switching into Sleep Mode. So after switching into Sleep Mode the CAN transceiver is either in CAN SWK Mode or CAN WK Mode depending on CAN_x setting and SYSERR bit (If CAN is switched to off mode it is also off in Sleep Mode).

Table 14 CAN modes change when switching to Sleep Mode

Programmed CAN mode in Normal Mode	CAN_x bits	SYSERR bit	CAN mode in Sleep Mode	CAN_x bits
CAN OFF Mode	000	0	CAN OFF Mode	000
CAN WK Mode (no SWK)	001	0	CAN WK Mode (no SWK)	001
CAN Receive Only Mode (no SWK)	010	0	CAN WK Mode (no SWK)	001
CAN Normal Mode (no SWK)	011	0	CAN WK Mode (no SWK)	001
CAN OFF Mode	100	0	CAN OFF Mode	100
CAN SWK Mode	101	0	CAN SWK Mode	101
CAN SWK Mode	101	1	CAN WK Mode (no SWK)	101
CAN Receive Only Mode with SWK	110	0	CAN SWK Mode	101
CAN Receive Only Mode with SWK	110	1	CAN WK Mode (no SWK)	101
CAN Normal Mode with SWK	111	0	CAN SWK Mode	101
CAN Normal Mode with SWK	111	1	CAN WK Mode (no SWK)	101

5.9.4.4 Restart Mode with SWK

If Restart Mode is entered the transceiver can change the CAN mode. During Restart or after Restart the following modes are possible:

- CAN OFF Mode
- CAN WK Mode (either still wake cable or already woken up)
- CAN SWK Mode (WUF Wake from Sleep)

Table 15 CAN modes change in case of Restart out of Normal Mode

Programmed CAN mode in Normal Mode	CAN_x bits	SYSERR bit	CAN mode in and after Restart Mode	CAN_x bits	SYSERR bit
CAN OFF Mode	000	0	CAN OFF Mode	000	0
CAN WK Mode (no SWK)	001	0	CAN WK Mode (no SWK)	001	0
CAN Receive Only Mode (no SWK)	010	0	CAN WK Mode (no SWK)	001	0
CAN Normal Mode (no SWK)	011	0	CAN WK Mode (no SWK)	001	0
CAN OFF Mode	100	0	CAN OFF Mode	100	0
CAN SWK Mode	101	0	CAN WK Mode (no SWK)	101	1
CAN SWK Mode	101	1	CAN WK Mode (no SWK)	101	1
CAN Receive Only Mode with SWK	110	0	CAN WK Mode (no SWK)	101	1
CAN Receive Only Mode with SWK	110	1	CAN WK Mode (no SWK)	101	1
CAN Normal Mode with SWK	111	0	CAN WK Mode (no SWK)	101	1
CAN Normal Mode with SWK	111	1	CAN WK Mode (no SWK)	101	1

The various reasons for entering Restart Mode and the respective status flag settings are shown in [Table 16](#).

Table 16 CAN modes change in case of Restart out of Sleep Mode

CAN mode in Sleep Mode	CAN mode in and after Restart Mode	CAN_x	SYS ERR	CAN_WU	WUP	WUF	ECNT_x	Reason for Restart
CAN OFF Mode	CAN off	000	0	0	0	0	0	Wake on other wake source
CAN WK Mode	CAN woken up	001	0	1	1	0	0	Wake (WUP) on CAN
CAN WK Mode	CAN WK Mode	001	0	0	0	0	0	Wake on other wake source
CAN SWK Mode	CAN woken up	101	0	1	0/1 ¹⁾	1	x	Wake (WUF) on CAN
CAN SWK Mode,	CAN woken up	101	1	1	0/1 ²⁾	0	100000	Wake due to error counter overflow
CAN SWK selected, CAN WK active	CAN woken up.	101	1	1	1	0	0	Wake (WUP) on CAN, config check was not pass
CAN SWK Mode	CAN WK Mode	101	1	0	0/1	0	x	Wake on other wake source

- 1) In case there is a WUF detection within $t_{SILENCE}$ then the WUP bit will not be set. Otherwise it will always be set together with the WUF bit.
- 2) In some cases the WUP bit might stay cleared even after $t_{SILENCE}$, e.g. when the error counter expires without detecting a wake-up pattern.

5.9.4.5 Fail-Safe Mode with SWK

When Fail-Safe Mode is entered the CAN transceiver is automatically set into CAN WK Mode (wake capable) without the selective wake function.

5.9.5 Wake-up

A wake-up via CAN leads to a restart out of Sleep Mode and to an interrupt in Normal Mode, and in Stop Mode. After the wake event the bit CAN_WU is set, and the details about the wake can be read out of the bits WUP, WUF, SYSERR, and ECNT.

5.9.6 Configuration for SWK

The CAN protocol handler settings can be configured in following registers:

- **SWK_BTL1_CTRL** defines the number of time quanta in a bit time. This number depends also on the internal clock settings performed in the register **SWK_CDR_CTRL**.
- **SWK_BTL1_CTRL** defines the sampling point position.
- The respective receiver during frame detection mode can be selected via the bit **RX_WK_SEL**.
- The clock and data recovery (see also **Chapter 5.9.8**) can be configured in the registers **SWK_CDR_CTRL** and **SWK_CDR_LIMIT**.

The actual configuration for selective wake is done via the Selective Wake Control Registers SWK_IDx_CTRL, SWK_MASK_IDx_CTRL, SWK_DLC_CTRL, SWK_DATAx_CTRL.

The oscillator has the option to be trimmed by the microcontroller. To measure the oscillator, the SPI bit OSC_CAL needs to be set to 1 and a defined pulse needs to be given to the TXDCAN pin by the microcontroller (e.g. 1µs pulse, CAN needs to be switched off before). The device measures the length of the pulse by counting the time with the integrated oscillator. The counter value can be read out of the register SWK_OSC_CAL_H_STATE and SWK_OSC_CAL_L_STATE. To change the oscillator the trimming function needs to be enabled by setting the bits TRIM_EN_x = 11 (and OSC_CAL = 1). The oscillator can then be adjusted by writing into the register **SWK_OSC_TRIM_CTRL**. To finish the trimming, the bits TRIM_EN_x need to be set back to “00”.

5.9.7 CAN Flexible Data Rate (CAN FD) Tolerant Mode

The CAN FD tolerant mode can be activated by setting the bit **CAN_FD_EN** = ‘1’ in the register **SWK_CAN_FD_CTRL**.

With this mode the internal CAN frame decoding will be stopped for CAN FD frame formats:

- The high baudrate part of a CAN FD frame will be ignored.
- No Error Handling (Bit Stuffing, CRC checking, Form Errors) will be applied to remaining CAN frame fields (Data Field, CRC Field, ...).
- No wake up is done on CAN FD frames.

The internal CAN frame decoder will be ready for new CAN frame reception when the End of frame (EOF) of a CAN FD frame is detected. The identification for a CAN FD frame is based on the EDL Bit, which is sent in the Control Field of a CAN FD frame:

- EDL Bit = 1 identifies the current frame as an CAN FD frame and will stop further decoding on it.
- EDL Bit = 0 identifies the current frame as CAN 2.0 frame and processing of the frame will be continued.

In this way it is possible to send mixed CAN frame formats without affecting the selective wake functionality by error counter increment and subsequent misleading wake up. In addition to the **CAN_FD_EN** bit also a filter setting must be provided for the CAN FD tolerant mode. This filter setting defines the minimum dominant time for a CAN FD dominant bit which will be considered as a dominant bit from the CAN FD frame decoder. This value must be aligned with the selected high baudrate of the data field in the CAN network.

To support programming via CAN during CAN FD mode a dedicated SPI bit **DIS_ERR_CNT** is available to avoid an overflow of the implemented error counter (see also **Chapter 5.9.2.4**).

The behavior of the error counter depends on the setting of the bits **DIS_ERR_CNT** and **CAN_FD_EN** and is show in below table:

Table 17 Error Counter Behavior

DIS_ERR_CNT setting	CAN_FD_EN setting	Error Counter Behavior
0	0	Error Counter counts up when a CAN FD frame or an incorrect/corrupted CAN frame is received; counts down when a CAN frame is received properly (as specified in ISO11898-2:2016)
1	0	Error Counter counts up when a CAN FD frame or an incorrect/corrupted CAN frame is received; counts down when a CAN frame is received properly (as specified in ISO11898-2:2016)

Table 17 Error Counter Behavior (cont'd)

DIS_ERR_CNT setting	CAN_FD_EN setting	Error Counter Behavior
0	1	Error Counter counts up when an incorrect/corrupted CAN frame is received; counts down when correct, including CAN FD frame, is received
1	1	Error Counter is and stays cleared to avoid an overflow during programming via CAN

The **DIS_ERR_CNT** bit is automatically cleared at **t_{SILENCE}** expiration.

5.9.8 Clock and Data Recovery

In order to compensate possible deviations on the CAN oscillator frequency caused by assembly and lifetime effects, the device features an integrated clock and data recovery (CDR).

It is recommended to always enable the CDR feature during SWK operation.

5.9.8.1 Configuring the Clock Data Recovery for SWK

The Clock and Data Recovery can be optionally enabled or disabled with the **CDR_EN** bit in the **SWK_CDR_CTRL** SPI register. In case the feature is enabled, the CAN bit stream will be measured and the internal clock used for the CAN frame decoding will be updated accordingly.

Before the Clock and Data Recovery can be used it must be configured properly related to the used baud rate and filtering characteristics (see [Chapter 5.9.8.2](#)).

It is strongly recommended not to enable/disable the Clock Recovery during a active CAN Communication.

To ensure this, it is recommended to enable/disable it during CAN off (**BUS_CTRL**; CAN[2:0] = 000).

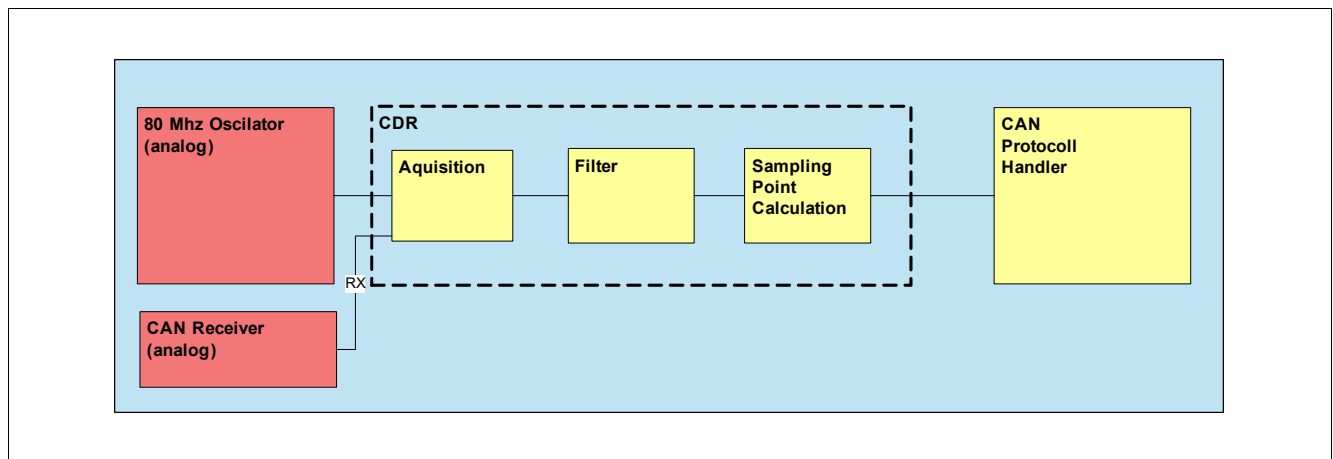

Figure 26 Clock and Data Recovery Block Diagram

5.9.8.2 Setup of Clock and Data Recovery

It is strongly recommended to enable the clock and data recovery feature only when the setup of the clock and data recovery is finished.

The following sequence should be followed for enabling the clock and data recovery feature:

- Step 1: Switch CAN to off and **CDR_EN** to off
Write SPI Register **BUS_CTRL** (CAN[2:0] = 000).
- Step 2: Configure CDR Input clock frequency
Write SPI Register **SWK_CDR_CTRL** (SEL_OSC_CLK[1:0]).
- Step 3: Configure Bit timing Logic
Write SPI Register **SWK_BTL1_CTRL** and adjust **SWK_CDR_LIMIT** according to **Table 84**.
- Step 4: Enable Clock and Data Recovery
Choose filter settings for Clock and Data recovery. Write SPI Register **SWK_CDR_CTRL** with **CDR_EN** = 1.

Additional hints for the CDR configuration and operation:

- Even if the CDR is disabled, when the baud rate is changed, the settings of **SEL_OSC_CLK** in the register **SWK_CDR_CTRL** and **SWK_BTL1_CTRL** have to be updated accordingly.
- The **SWK_CDR_LIMIT** registers has to be also updated when the baud rate or clock frequency is changed (the CDR is discarding all the acquisitions and loses all acquired information, if the limits are reached - the **SWK_BTL1_CTRL** value is reloaded as starting point for the next acquisitions).
- When updating the CDR registers, it is recommended to disable the CDR and to enable it again only after the new settings are updated.
- The **SWK_BTL1_CTRL** register represents the sampling point position. It is recommended to be used at default value: 11 0011 (~80%).

5.9.9 Electrical Characteristics

Table 18 Electrical Characteristics

$V_{SINT} = 5.5\text{ V to }28\text{ V}$; $T_j = -40^\circ\text{C to }+150^\circ\text{C}$; $4.75\text{ V} < V_{CAN} < 5.25\text{ V}$; $R_L = 60\ \Omega$; CAN Normal Mode; all voltages with respect to ground, positive current flowing into pin (unless otherwise specified)

Parameter	Symbol	Values			Unit	Note or Test Condition	Number
		Min.	Typ.	Max.			
CAN Partial Network Timing							
Bus Bias reaction time	t_{bias}	–	–	250	μs	¹⁾ Load $R_L = 60\ \Omega$, $C_L = 100\ \text{pF}$, $C_{GND} = 100\ \text{pF}$	P_5.10.2
Wake-up reaction time (WUP or WUF)	$t_{WU_WUP/WUF}$	–	–	100	μs	¹⁾²⁾³⁾ Wake-up reaction time after a valid WUP or WUF;	P_5.10.3
Min. Bit Time	t_{Bit_min}	1	–	–	μs	¹⁾⁴⁾	P_5.10.4

Table 18 Electrical Characteristics (cont'd)

$V_{SINT} = 5.5\text{ V to }28\text{ V}$; $T_j = -40^\circ\text{C to }+150^\circ\text{C}$; $4.75\text{ V} < V_{CAN} < 5.25\text{ V}$; $R_L = 60\ \Omega$; CAN Normal Mode; all voltages with respect to ground, positive current flowing into pin (unless otherwise specified)

Parameter	Symbol	Values			Unit	Note or Test Condition	Number
		Min.	Typ.	Max.			
CAN FD Tolerance⁵⁾							
SOF acceptance	$n_{\text{Bits_idle}}$	6	-	10	bits	⁶⁾ Number of recessive bits before a new SOF shall be accepted	P_5.10.5
Dominant signals which are ignored (up to 2MBit/s)	$t_{\text{FD_Glitch_4}}$	0	-	5	%	⁶⁾⁷⁾⁸⁾ of arbitration bit time; to be configured via FD_FILTER ;	P_5.10.6
Dominant signals which are ignored (up to 5MBit/s)	$t_{\text{FD_Glitch_10}}$	0	-	2.5	%	⁶⁾⁸⁾⁹⁾ of arbitration bit time; to be configured via FD_FILTER ;	P_5.10.7
Signals which are detected as a dominant data bit after the FDF bit and before EOF bit (up to 2MBit/s)	$t_{\text{FD_DOM_4}}$	17.5	-	-	%	⁶⁾⁷⁾⁸⁾ of arbitration bit time; to be configured via FD_FILTER ;	P_5.10.8
Signals which are detected as a dominant data bit after the FDF bit and before EOF bit (up to 5MBit/s)	$t_{\text{FD_DOM_10}}$	8.75	-	-	%	⁶⁾⁸⁾⁹⁾ of arbitration bit time; to be configured via FD_FILTER ;	P_5.10.9

- 1) Not subject to production test, tolerance defined by internal oscillator tolerance.
- 2) Wake-up is signaled via INTN pin activation in Stop Mode and via VCC1 ramping up with wake from Sleep Mode.
- 3) For WUP: time starts with end of last dominant phase of WUP; for WUF: time starts with end of CRC delimiter of the WUF.
- 4) The minimum bit time corresponds to a maximum bit rate of 1 Mbit/s. The lower end of the bit rate depends on the protocol IC or the permanent dominant detection circuitry preventing a permanently dominant clamped bus.
- 5) Applies for an arbitration rate of up to 500 kbps until the FDF bit is detected.
- 6) Not subject to production test; specified by design.
- 7) A data phase bit rate less or equal to four times of the arbitration bit rate or 2 Mbit/s, whichever is lower.
- 8) Parameter applies only for the Normal Mode CAN receiver ($RX_WK_sel = 1$).
- 9) A data phase bit rate less or equal to four times of the arbitration bit rate or 5 Mbit/s, whichever is lower.

Voltage Regulator 1

6 Voltage Regulator 1

6.1 Block Description

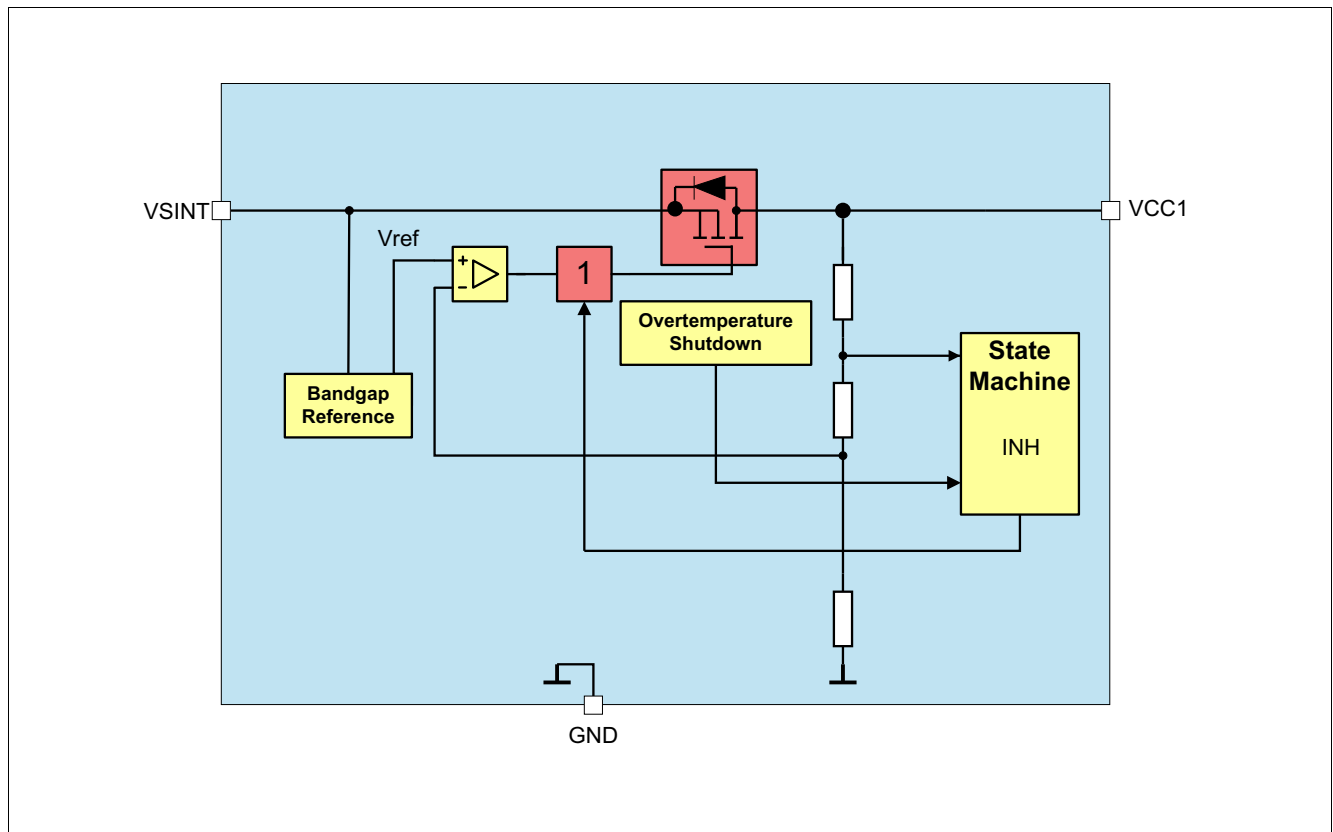

Figure 27 Module Block Diagram

Functional Features

- 5 V low-drop voltage regulator.
- Undervoltage monitoring with adjustable reset level and VCC1 undervoltage prewarning (refer to [Chapter 13.7](#) and [Chapter 13.8](#) for more information).
- Short circuit detection and switch off with undervoltage fail threshold, device enters Fail-Safe Mode.
- Effective capacitance must be $\geq 1 \mu\text{F}$ at nominal voltage output for stability. A $2.2 \mu\text{F}$ ceramic capacitor (MLCC) is recommended for best transient response.
- Output current capability up to $I_{VCC1,lim}$.

Voltage Regulator 1

6.2 Functional Description

The Voltage Regulator 1 (=VCC1) is “ON” in Normal Mode and Stop Mode and is disabled in Sleep Mode and in Fail-Safe Mode. The regulator can provide an output current up to $I_{VCC1,lim}$.

For low-quiescent current reasons, the output voltage tolerance is decreased in Stop Mode because only the less accurate low-power mode regulator will be active for small loads. If the load current on VCC1 exceeds the selected threshold ($I_{VCC1,peak1,r}$ or $I_{VCC1,peak2,r}$) then the high-power mode regulator will be also activated to support an optimum dynamic load behavior. The current consumption will then increase (approx. 2.8 mA additional quiescent current). The device mode stays unchanged.

If the load current on VCC1 falls below the selected threshold ($I_{VCC1,peak1,f}$ or $I_{VCC1,peak2,f}$), then the low-quiescent current mode is resumed again by disabling the high-power mode regulator.

Both regulators (low-power mode and high-power mode) are active in Normal Mode.

Two different active peak thresholds can be selected via SPI:

- **I_PEAK_TH** = ‘0’ (default): the lower VCC1 active peak threshold 1 is selected with lowest quiescent current consumption in Stop Mode.
- **I_PEAK_TH** = ‘1’: the higher VCC1 active peak threshold 2 is selected with an increased quiescent current consumption in Stop Mode.

Voltage Regulator 1

6.3 Electrical Characteristics

Table 19 Electrical Characteristics

$V_{SINT} = 5.5\text{ V to }28\text{ V}$; $T_j = -40^\circ\text{C to }+150^\circ\text{C}$; all voltages with respect to ground, positive current flowing into pin (unless otherwise specified).

Parameter	Symbol	Values			Unit	Note or Test Condition	Number
		Min.	Typ.	Max.			
Output Voltage including Line and Load Regulation	$V_{CC1,out1}$	4.9	5.0	5.1	V	¹⁾ Normal Mode; $10\ \mu\text{A} < I_{VCC1} < 150\ \text{mA}$;	P_6.3.1
Output Voltage including Line and Load Regulation (Full Load Current Range)	$V_{CC1,out2}$	4.9	5.0	5.1	V	¹⁾ Normal Mode; $6\ \text{V} < V_{SINT} < 28\ \text{V}$; $10\ \mu\text{A} < I_{VCC1} < 250\ \text{mA}$	P_6.3.2
Output Voltage including Line and Load Regulation (Higher Accuracy Range)	$V_{CC1,out3}$	4.95	–	5.05	V	²⁾ Normal Mode; $20\ \text{mA} < I_{VCC1} < 80\ \text{mA}$; $8\ \text{V} < V_{SINT} < 18\ \text{V}$; $25^\circ\text{C} < T_j < 150^\circ\text{C}$	P_6.3.3
Output Voltage including Line and Load Regulation (low-power mode)	$V_{CC1,out4}$	4.9	5.05	5.2	V	Stop Mode; $10\ \mu\text{A} < I_{VCC1} < I_{VCC1,peak}$	P_6.3.4
Output Drop Voltage	$V_{CC1,d1}$	–	200	400	mV	$I_{VCC1} = 50\ \text{mA}$, $V_{SINT} = 5\ \text{V}$	P_6.3.9
Output Drop Voltage	$V_{CC1,d2}$	–	300	500	mV	$I_{VCC1} = 150\ \text{mA}$, $V_{SINT} = 5\ \text{V}$	P_6.3.10
VCC1 Active Peak Threshold 1 (Transition threshold between low-power and high-power mode regulator)	$I_{VCC1,lpeak1,r}$	–	3.25	5.0	mA	²⁾ I_{CC1} rising; $V_{SINT} = 13.5\ \text{V}$; $I_PEAK_TH = '0'$	P_6.3.17
VCC1 Active Peak Threshold 1 (Transition threshold between high-power and low-power mode regulator)	$I_{VCC1,lpeak1,f}$	1.2	1.7	–	mA	²⁾ I_{CC1} falling; $V_{SINT} = 13.5\ \text{V}$; $I_PEAK_TH = '0'$	P_6.3.18
VCC1 Active Peak Threshold 2 (Transition threshold between low-power and high-power mode regulator)	$I_{VCC1,lpeak2,r}$	6	–	20	mA	²⁾ I_{CC1} rising; $V_{SINT} = 13.5\ \text{V}$; $I_PEAK_TH = '1'$	P_6.3.19
VCC1 Active Peak Threshold 2 (Transition threshold between high-power and low-power mode regulator)	$I_{VCC1,lpeak2,f}$	5	–	15	mA	²⁾ I_{CC1} falling; $V_{SINT} = 13.5\ \text{V}$; $I_PEAK_TH = '1'$	P_6.3.20
Overcurrent Limitation	$I_{VCC1,lim}$	260	360	500	mA	current following out of pin, $V_{CC1} = 0\ \text{V}$ ²⁾	P_6.3.21

Voltage Regulator 1

Table 19 Electrical Characteristics (cont'd)

$V_{SINT} = 5.5 \text{ V to } 28 \text{ V}$; $T_j = -40^\circ\text{C to } +150^\circ\text{C}$; all voltages with respect to ground, positive current flowing into pin (unless otherwise specified).

Parameter	Symbol	Values			Unit	Note or Test Condition	Number
		Min.	Typ.	Max.			
Minimum Output Capacitance for stability	$C_{VCC1,min}$	1 ³⁾	–	–	μF	²⁾	P_6.3.22
Maximum Output Capacitance	$C_{VCC1,max}$	–	–	47	μF	²⁾	P_6.3.23

- 1) In Stop Mode, the specified output voltage tolerance applies when I_{VCC1} has exceeded the selected active peak threshold ($I_{VCC1,peak1,r}$ or $I_{VCC1,peak2,r}$) but with increased current consumption.
- 2) Not subject to production test, specified by design.
- 3) Value is meant to be an effective value at rated output voltage level.

7 High-Side Switch

7.1 Block Description

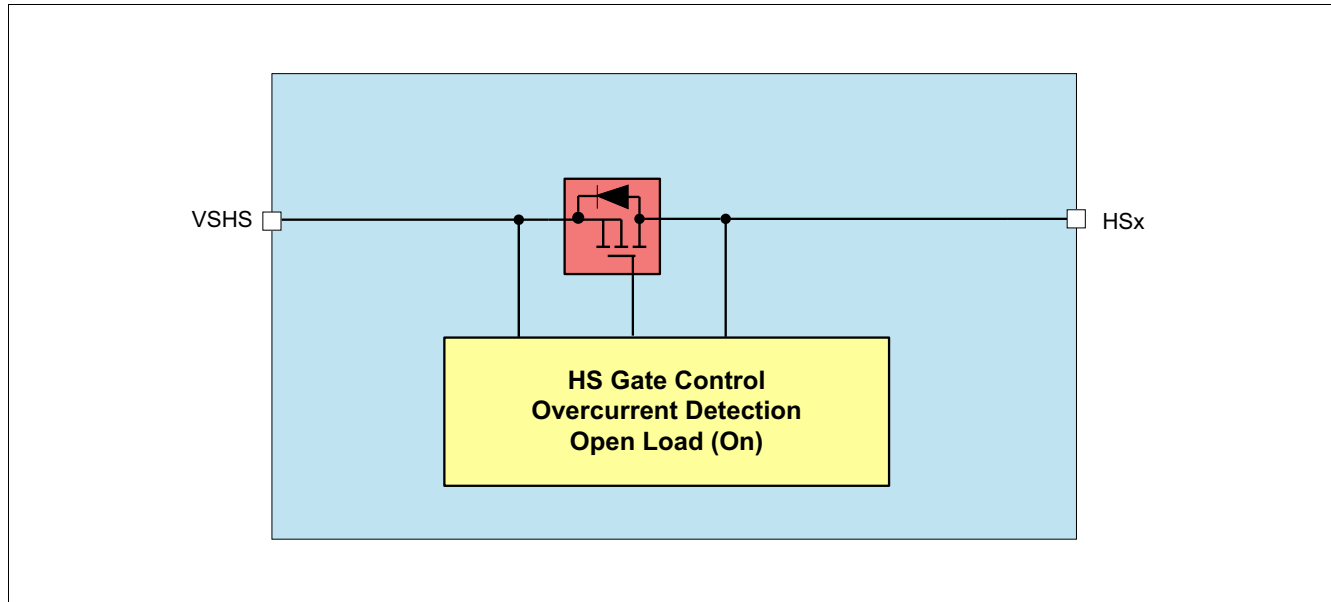

Figure 28 High-Side Module Block Diagram

Features

- All HSx supplied by VSHS
- Under voltage switch off configurable via SPI.
- Dedicated over voltage switch off per each HSx in Normal Mode- configurable via SPI.
- Overvoltage switch off in Stop Mode and Sleep Mode- configurable via SPI.
- Overcurrent detection and switch off.
- Open load detection in ON-state.
- PWM capability with internal or external timers configurable via SPI.
- Switch recovery after removal of OV or UV condition configurable via SPI.

7.2 Functional Description

The High-Side switches can be used for control of LEDs, as supply for the wake inputs and for other loads (except inductive load). The High-Side outputs can be controlled either directly via SPI by the integrated timers or by the integrated PWM generators or by external sync signal (using WK4/SYNC pin).

The high-side outputs are supplied by VSHS pin. The topology supports improved cranking condition behavior.

The configuration of the High-Sides (Permanent On, PWM, cyclic sense, etc.) drivers must be done in Normal Mode. The configuration is taken over in Stop Mode or Sleep Mode and cannot be modified. When entering Restart Mode or Fail-Safe Mode the HSx outputs are disabled.

High-Side Switch

7.2.1 Under Voltage Switch Off

All HS drivers in on-state are switched off in case of under voltage on VSHS. The feature can be disabled by setting the SPI bit **HS_UV_SD_DIS**.

After release of under voltage condition, the HSx switch goes back to programmed state in which it was configured via SPI. This behavior is only valid if the bit **HS_UV_REC** is set. Otherwise the switches will stay off and the respective SPI control bits are cleared.

The under voltage is signaled in the bit **HS_UV**, no other error bits are set.

7.2.2 Over Voltage Switch Off

The HS drivers in on-state are switched off in case of over voltage on VSHS.. In Normal Mode the HSx can be kept in on-state above the VSHS overvoltage threshold if the HSx_OV_SDN_DIS bit is set.

In Stop Mode or Sleep Modes all HS drivers can be kept in on-state if **HS_OV_SDS_DIS** bit is set.

When the HSx are configured to switch off in case of over voltage condition, after release of over voltage condition, the HS switch goes back to programmed state in which it was configured via SPI. This behavior is only valid if the respective bit HSx_OV_REC is set. Otherwise the switch will stay off and the respective SPI control bits are cleared. This configuration is available for each HSx.

The over voltage is signaled in the bit **HS_OV**, no other error bits are set.

7.2.3 Over Current Detection and Switch Off

If the load current exceeds the over current shutdown threshold for a time longer then the over current shutdown filter time the output is switched off.

The over current condition and the switch off is signaled with the respective HSx_OC_OT bit in the register **HS_OL_OC_OT_STAT**. The HSx configuration is then reset to 000 by the device. To activate the High-Side again the HSx configuration has to be set to ON (001) or be programmed to a timer function. It is recommended to clear the over current bit before activation the High-Side switch, as the bits are not cleared automatically by the device.

7.2.4 Open Load Detection

Open load detection on the High-Side outputs is done during on state of the output. If the current in the activated output falls below the open load detection current threshold, the open load is detected and signaled via the respective bit HS1_OL, HS2_OL, HS3_OL, or HS4_OL in the register **HS_OL_OC_OT_STAT**. The High-Side output stays activated.. If the open load condition disappears the Open Load bit in the SPI can be cleared. The bits are not cleared automatically by the device.

7.2.5 PWM, Timer and SYNC Function

Each integrated HSx can be configured in different ways, in particular:

- Static OFF
- Static ON
- Timer 1
- Timer 2
- Internal generator PWM1
- Internal generator PWM2
- Internal generator PWM3
- Internal generator PWM4

High-Side Switch

- SYNC (via WK4)

Note: PWMx mentioned in this chapter refer to the internal PWM generators, which are configured by the registers **HS_CTRL** and **PWM_CTRL**. They can be used to control the internal high-side switches HSx.

Note: PWMx mentioned in this chapter **do not refer** to the PWMx pins. The PWMx pins are used for the PWM operation of the bridge drivers, to control the external MOSFETs.

Static configuration (ON/OFF)

This configuration set the HSx permanently ON or OFF. This configuration is available in Normal Mode, Stop Mode and Sleep Mode.

The configuration shall be done via SPI.

Timer configuration (TIMER1 or TIMER2)

Two Timers are dedicated to control the ON phase of dedicated HS outputs.

The Timers are mapped to the dedicated HS outputs. Period and the duty cycle can be independently configured with via SPI.

PWM configuration (PWM1..PWM4)

Several internal PWM generators are dedicated to generate a PWM signal on the HSx output, e.g. for brightness adjustment or compensation of supply voltage fluctuation. The PWM generators are mapped to the dedicated HS outputs, and the duty cycle can be independently configured with a 10-bit resolution via SPI (**PWM_CTRL**). Two different frequencies can be selected independently for every PWM generator in the register **PWM_CTRL**.

In order to assign and configure the PWMx to specific HSX, the follow steps have to be followed:

- Configure duty cycle and frequency for respective PWM generator in **PWM_CTRL**.
- Assign PWM generator to respective HS switch(es) in **HSx_CTRL**.
- The PWM generation will start right after the HSx is assigned to the PWM generator (**HS_CTRL**).

Note: The min. on-time during PWM is limited by the actual on- and off-time of the respective HS switch, e.g. the PWM setting '00 0000 0001' could not be realized.

SYNC configuration (using WK4)

Another possible configuration is to use the WK4 (set as SYNC pin) and mapped to one dedicated HSx output.

The configuration of the WK4/SYNC bit is done using the **WK_EN** bits. If the **WK_EN**=10_B (SYNC selected), all bits in WK4 bank are ignored and wake-up capability on WK4 is not available.

Only after the WK4/SYNC configuration, the HSx can be configured for SYNC usage (HSx = 1000_B).

High-Side Switch

7.3 Electrical Characteristics

Table 20 Electrical Characteristics

$V_{SINT} = 5.5\text{ V to }28\text{ V}$; $T_j = -40^\circ\text{C to }+150^\circ\text{C}$; all voltages with respect to ground, positive current flowing into pin (unless otherwise specified)

Parameter	Symbol	Values			Unit	Note or Test Condition	Number
		Min.	Typ.	Max.			
Output HS1, HS2, HS3, HS4							
Static Drain-Source ON Resistance HSx	$R_{ON,HS25}$	–	7	–	Ω	$I_{ds} = 60\text{ mA}$, $T_j < 25^\circ\text{C}$	P_7.3.1
Static Drain-Source ON Resistance HSx	$R_{ON,HS150}$	–	11.5	16	Ω	$I_{ds} = 60\text{ mA}$, $T_j < 150^\circ\text{C}$	P_7.3.2
Leakage Current HSx / per channel	$I_{leak,HS}$	–	–	2	μA	¹⁾ $0\text{ V} < V_{HSx} < V_{S,HS}$; $T_j < 85^\circ\text{C}$	P_7.3.3
Output Slew Rate (rising)	$SR_{raise,HS}$	0.8	–	2.5	$\text{V}/\mu\text{s}$	¹⁾ 20 to 80% $V_{SHS} = 6\text{ to }18\text{ V}$ $R_L = 220\ \Omega$	P_7.3.4
Output Slew Rate (falling)	$SR_{fall,HS}$	-2.5	–	-0.8	$\text{V}/\mu\text{s}$	¹⁾ 80 to 20% $V_{SHS} = 6\text{ to }18\text{ V}$ $R_L = 220\ \Omega$	P_7.3.5
Switch-on time HSx	$t_{ON,HS}$	3	–	30	μs	CSN = HIGH to $0.8 \times V_{SHS}$; $R_L = 220\ \Omega$; $V_{SHS} = 6\text{ to }18\text{ V}$	P_7.3.6
Switch-off time HSx	$t_{OFF,HS}$	3	–	30	μs	CSN = HIGH to $0.2 \times V_{SHS}$; $R_L = 220\ \Omega$; $V_{SHS} = 6\text{ to }18\text{ V}$	P_7.3.7
Short Circuit Shutdown Current	$I_{SD,HS}$	150	245	300	mA	$V_{SHS} = 6\text{ to }20\text{ V}$	P_7.3.8
Short Circuit Shutdown Filter Time	$t_{SD,HS}$	12	16	22	μs	²⁾	P_7.3.9
Open Load Detection Current	$I_{OL,HS}$	0.4	–	2	mA	hysteresis included	P_7.3.10
Open Load Detection hysteresis	$I_{OL,HS,hys}$	–	0.45	–	mA	¹⁾	P_7.3.11
Open Load Detection Filter Time	$t_{OL,HS}$	160	220	270	μs	²⁾	P_7.3.12

1) Not subject to production test, specified by design.

2) Not subject to production test, tolerance defined by internal oscillator tolerance.

8 High Speed CAN Transceiver

8.1 Block Description

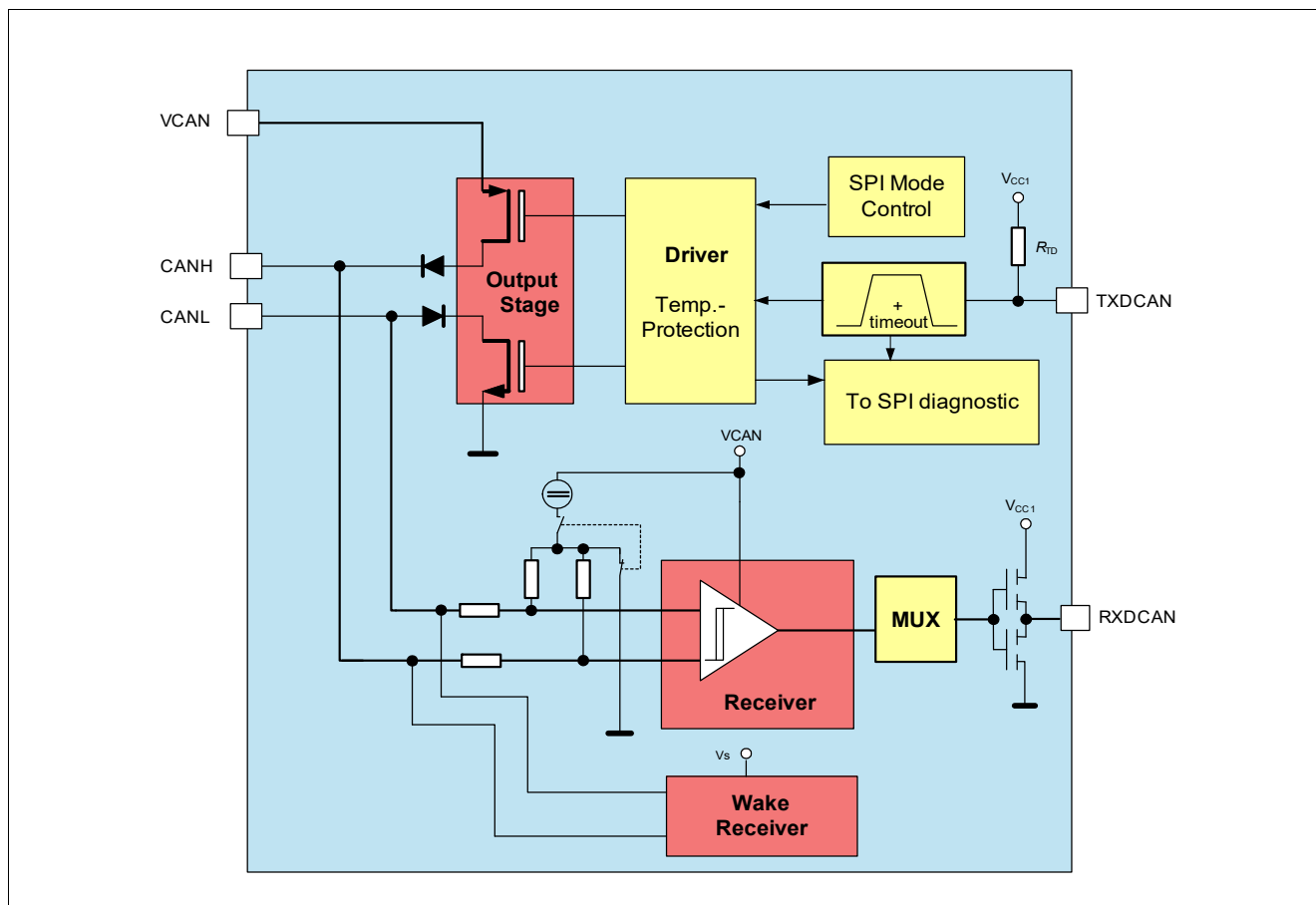

Figure 29 Functional Block Diagram

8.2 Functional Description

The Controller Area Network (CAN) transceiver part of the device provides High-Speed (HS) differential mode data transmission (up to 2 Mbaud/s) and reception in automotive and industrial applications. It works as an interface between the CAN protocol controller and the physical bus lines compatible to ISO11898-2:2016 and SAE J2284.

The CAN FD transceiver offers low-power modes to reduce current consumption. This supports networks with partially powered down nodes. To support software diagnostic functions, a CAN Receive Only Mode is implemented.

It is designed to provide excellent passive behavior when the transceiver is switched off (mixed networks, clamp 15/30 applications).

A wake-up from the CAN Wake Capable Mode is possible via a message on the bus. Thus, the microcontroller can be powered down or idled and is woken up by the CAN bus activities.

The CAN transceiver is designed to withstand the severe conditions of automotive applications and to support 12 V applications.

High Speed CAN Transceiver

The transceiver can also be configured to Wake Capable in order to save current and to ensure a safe transition from Normal Mode to Sleep Mode (to avoid losing messages).

Figure 30 shows the possible transceiver mode transition when changing the device mode.

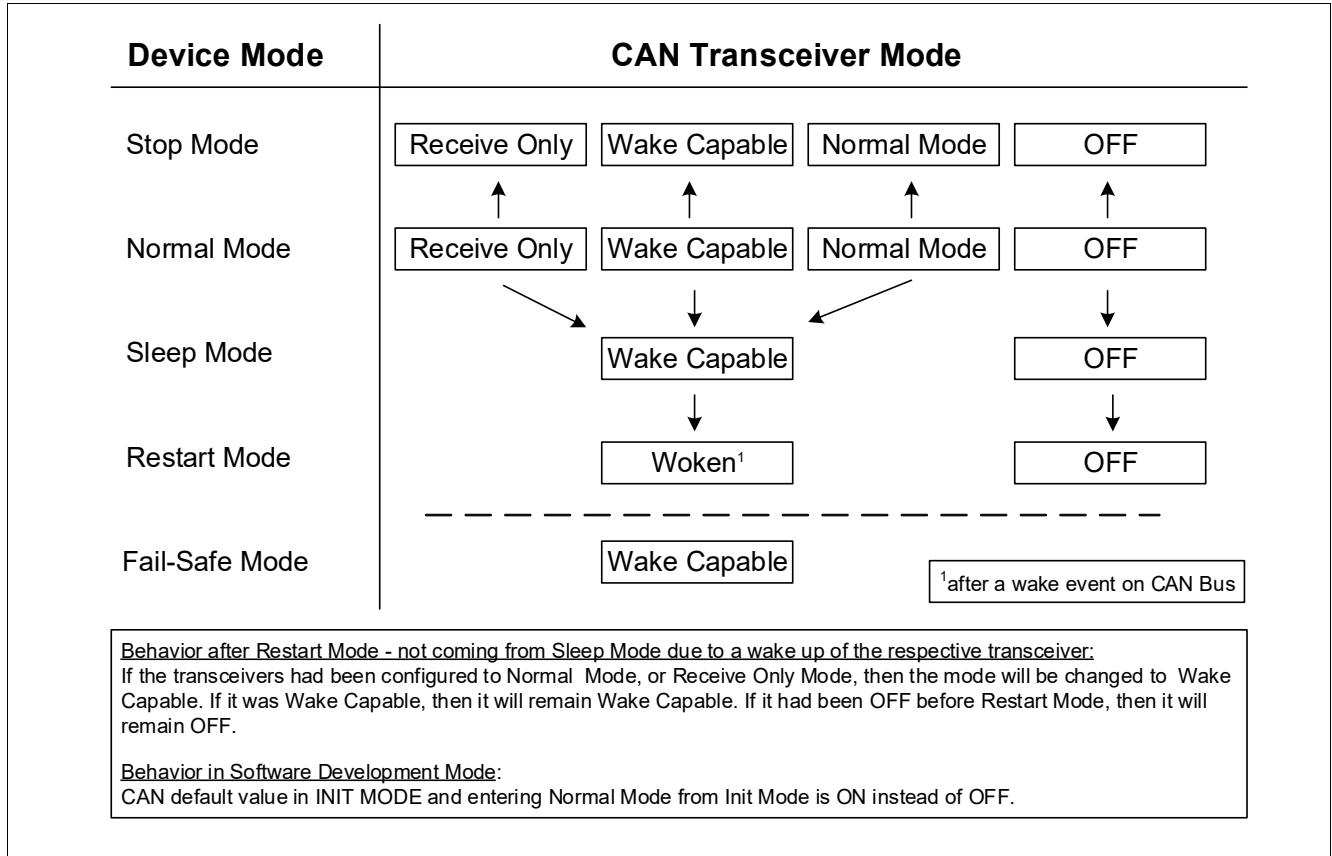

Figure 30 CAN Mode Control Diagram

CAN FD Support

CAN FD stands for ‘CAN with Flexible Data Rate’. It is based on the well established CAN protocol as specified in ISO11898-2:2016. CAN FD still uses the CAN bus arbitration method. The benefit is that the bit rate can be increased by switching to a shorter bit time at the end of the arbitration process and then to return to the longer bit time at the CRC delimiter, before the receivers transmit their acknowledge bits. See also **Figure 31**. In addition, the effective data rate is increased by allowing longer data fields. CAN FD allows the transmission of up to 64 data bytes compared to the 8 data bytes from the standard CAN.

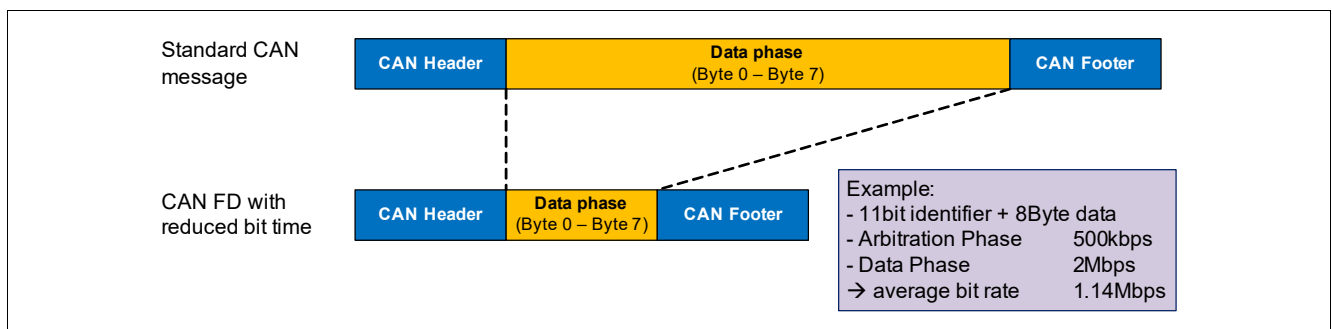

Figure 31 Bit Rate Increase with CAN FD vs. Standard CAN

High Speed CAN Transceiver

Not only the physical layer must support CAN FD but also the CAN controller. In case the CAN controller is not able to support CAN FD then the respective CAN node must at least tolerate CAN FD communication. This CAN FD tolerant mode is realized in the physical layer.

8.2.1 CAN OFF Mode

The CAN OFF Mode is the default mode after power-up of the device. It is available in all device modes and is intended to completely stop CAN activities or when CAN communication is not needed. In CAN OFF Mode, a wake-up event on the bus will be ignored.

8.2.2 CAN Normal Mode

The CAN Transceiver is enabled via SPI in Normal Mode. CAN Normal Mode is designed for normal data transmission/reception within the HS-CAN network. The mode is available in Normal Mode and in Stop Mode. The bus biasing is set to $V_{CAN}/2$.

Transmission

The signal from the microcontroller is applied to the TXDCAN input of the device. The bus driver switches the CANH/L output stages to transfer this input signal to the CAN bus lines.

Enabling sequence

The CAN transceiver requires an enabling time $t_{CAN,EN}$ before a message can be sent on the bus. This means that the TXDCAN signal can only be pulled low after the enabling time. If this is not ensured, then the TXDCAN needs to be set back to high (=recessive) until the enabling time is completed. Only the next dominant bit will be transmitted on the bus. **Figure 32** shows different scenarios and explanations for CAN enabling.

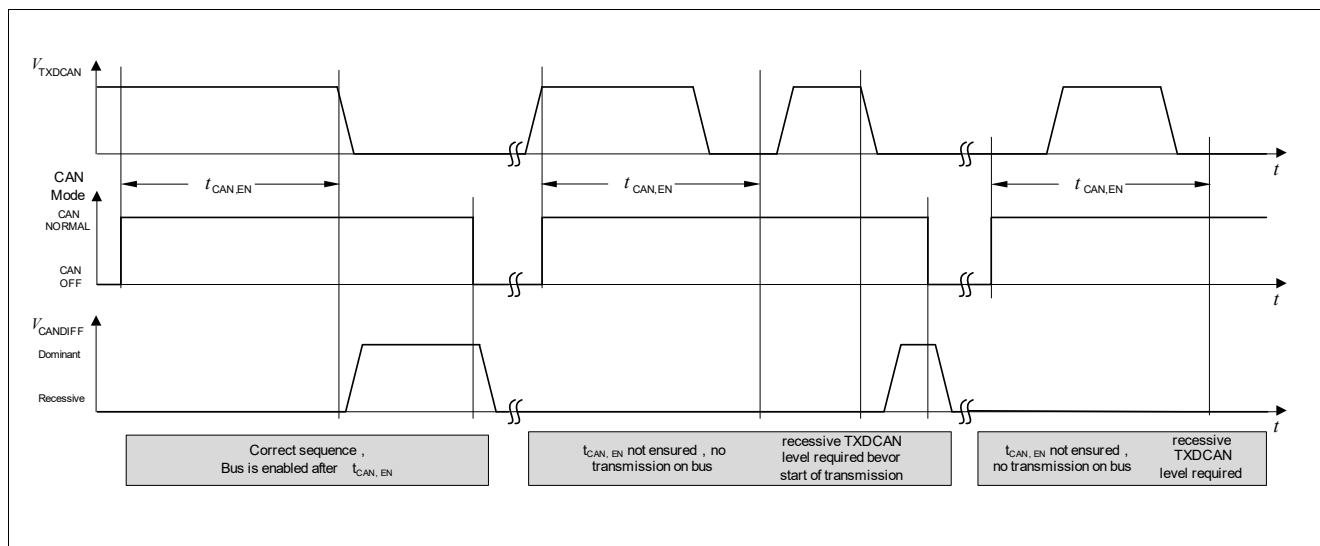

Figure 32 CAN Transceiver Enabling Sequence

Reduced Electromagnetic Emission

To reduce electromagnetic emissions (EME), the bus driver controls CANH/L slopes symmetrically.

Reception

Analog CAN bus signals are converted into digital signals at RXDCAN via the differential input receiver.

8.2.3 CAN Receive Only Mode

In CAN Receive Only Mode (RX only), the driver stage is de-activated but reception is still operational. This mode is accessible by an SPI command in Normal Mode and in Stop Mode.

High Speed CAN Transceiver

Note: The transceiver is still properly working in CAN Receive Only Mode even if VCAN is not available because of an independent receiver supply.

8.2.4 CAN Wake Capable Mode

This mode can be used in Stop Mode, Sleep Mode, Restart Mode and Normal Mode by programming via SPI and it is used to monitor bus activities. It is automatically accessed in Fail-Safe Mode. A wake-up signal on the bus results in a change of behavior of the device, as described in Table 21. As a signalization to the microcontroller, the RXDCAN pin is set low and will stay low until the CAN transceiver is changed to any other mode. After a wake-up event, the transceiver can be switched to CAN Normal Mode via SPI for bus communication.

As shown in Figure 33, a wake-up pattern (WUP) is signaled on the bus by two consecutive dominant bus levels for at least t_{Wake1} (wake-up time) and less than t_{Wake2} , each separated by a recessive bus level of greater than t_{Wake1} and shorter than t_{Wake2} .

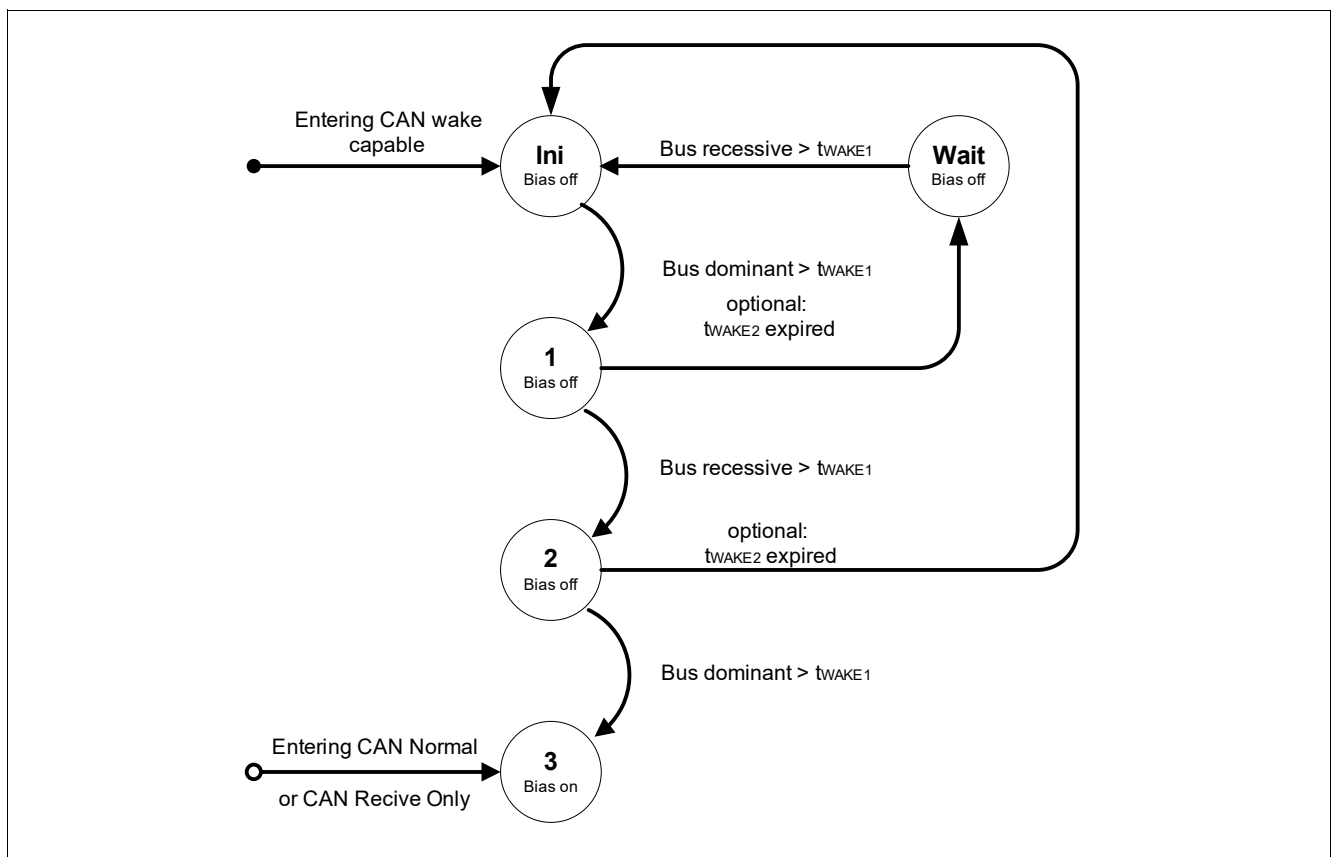

Figure 33 CAN Wake-up Pattern Detection according to the Definition in ISO11898-2:2016

Rearming the Transceiver for Wake Capability

After a BUS wake-up event, the transceiver is woken. However, the CAN transceiver mode bits will still show wake capable (=‘01’) so that the RXDCAN signal will be pulled low. There are two possibilities how the CAN transceiver’s wake capable mode is enabled again after a wake-up event:

- The CAN transceiver mode must be toggled, i.e. switched from CAN Wake Capable Mode to CAN Normal Mode, CAN Receive Only Mode or CAN OFF Mode, before switching to CAN Wake Capable Mode again.
- Rearming is done automatically when the device is changed to Stop Mode, Sleep Mode or Fail-Safe Mode to ensure wake-up capability.

High Speed CAN Transceiver

Wake-Up in Stop Mode and Normal Mode

In Stop Mode, if a wake-up is detected, it is always signaled by the INTN output and in the **WK_STAT** SPI register. It is also signaled by RXDCAN pulled to low. The same applies for the Normal Mode. The microcontroller should set the device from Stop Mode to Normal Mode, there is no automatic transition to Normal Mode.

For functional safety reasons, the watchdog will be automatically enabled in Stop Mode after a bus wake-up event in case it was disabled before (if bit **WD_EN_WK_BUS** was configured to high before).

Wake-Up in Sleep Mode

Wake-up is possible via a CAN message. The wake-up automatically transfers the device into the Restart Mode and from there to Normal Mode the corresponding RXDCAN pin is set to low. The microcontroller is able to detect the low signal on RXDCAN and to read the wake source out of the **WK_STAT** register via SPI. No interrupt is generated when coming out of Sleep Mode. The microcontroller can now for example switch the CAN transceiver into CAN Normal Mode via SPI to start communication.

Table 21 Action due to CAN Bus Wake-Up

Mode	Mode after Wake	VCC1	INTN	RXDCAN
Normal Mode	Normal Mode	On	Low	Low
Stop Mode	Stop Mode	On	Low	Low
Sleep Mode	Restart Mode	Ramping Up	High	Low
Restart Mode	Restart Mode	On	High	Low
Fail-Safe Mode	Restart Mode	Ramping Up	High	Low

8.2.5 CAN Bus termination

In accordance with the CAN configuration, four types of bus terminations are allowed:

- CAN Normal Mode: VCAN/2 termination.
- CAN Receive Only Mode: VCAN/2 termination in case that VCAN is nominal supply. when VCAN UV is detected, the termination is 2.5 V.
- CAN Wake Capable Mode: GND termination: after wake-up, the termination is 2.5 V.
- CAN OFF Mode: no termination necessary (bus floating).

When entering CAN Wake Capable Mode the termination is only connected to GND after the t_{silence} time has expired.

8.2.6 TXD Time-out Feature

If the TXDCAN signal is dominant for a time $t > t_{\text{TXDCAN_TO}}$, in CAN Normal Mode, the TXDCAN time-out function deactivates the transmission of the signal at the bus setting the TXDCAN pin to recessive. This is implemented to prevent the bus from being blocked permanently due to an error. The transmitter is disabled and thus switched to recessive state. The CAN SPI control bits (**CAN** on **BUS_CTRL**) remain unchanged and the failure is stored in the SPI flag **CAN_FAIL**. The CAN transmitter stage is activated again after the dominant time-out condition is removed and the transceiver is automatically switched back to CAN Normal Mode.

8.2.7 Bus Dominant Clamping

If the CAN bus is dominant for a time $t > t_{\text{BUS_CAN_TO}}$, when CAN is configured as CAN Normal Mode or CAN Receive Only Mode, a bus dominant clamping is detected and the SPI bit **CAN_FAIL** is set. The transceiver configuration stays unchanged. In order to avoid that a bus dominant clamping is detected due to a TXD time-out the bus dominant clamping filter time $t_{\text{BUS_CAN_TO}} > t_{\text{TXDCAN_TO}}$.

High Speed CAN Transceiver

8.2.8 Undervoltage Detection

The voltage at the CAN supply pin is monitored in CAN Normal Mode and CAN Receive Only Mode. In case of V_{CAN} undervoltage a signalization via SPI bit **V_{CAN_UV}** is triggered and the TLE9562-3QX disables the transmitter stage. If the CAN supply reaches a higher level than the undervoltage detection threshold (V_{CAN} > **V_{CAN_UV}**), the transceiver is automatically switched back to CAN Normal Mode.

The undervoltage detection is enabled if the mode bit CAN_1 = '1', i.e. in CAN Normal or CAN Receive Only Mode. .

8.3 Electrical Characteristics

Table 22 Electrical Characteristics

T_j = -40°C to +150°C; V_{SINT} = 5.5 V to 28 V; V_{CAN} = 4.75 V to 5.25 V; R_L = 60 Ω; CAN Normal Mode; all voltages with respect to ground, positive current flowing into pin (unless otherwise specified)

Parameter	Symbol	Values			Unit	Note or Test Condition	Number
		Min.	Typ.	Max.			
CAN Bus Receiver							
Differential Receiver Threshold Voltage, recessive to dominant edge	V _{diff,rd_N}	–	0.80	0.90	V	V _{diff} = V _{CANH} - V _{CANL} ; -12 V ≤ V _{CM} (CAN) ≤ 12 V; CAN Normal Mode	P_8.3.1
Differential Receiver Threshold Voltage, dominant to recessive edge	V _{diff,dr_N}	0.50	0.60	–	V	V _{diff} = V _{CANH} - V _{CANL} ; -12 V ≤ V _{CM} (CAN) ≤ 12 V; CAN Normal Mode	P_8.3.2
Dominant state differential input voltage range	V _{diff_D_range}	0.9	–	8.0	V	V _{diff} = V _{CANH} - V _{CANL} ; -12 V ≤ V _{CM} (CAN) ≤ +12 V; CAN Normal Mode	P_8.3.60
Common Mode Range	CMR	-12	–	12	V	4)	P_8.3.3
Recessive state differential input voltage range	V _{diff_R_range}	-3.0	–	0.5	V	V _{diff} = V _{CANH} - V _{CANL} ; -12 V ≤ V _{CM} (CAN) ≤ +12 V; CAN Normal Mode	P_8.3.61
Maximum Differential Bus Voltage	V _{diff,max}	-5	–	10	V	4)	P_8.3.4
CANH, CANL Input Resistance	R _i	20	40	50	kΩ	CAN Normal / Wake Capable Mode; Recessive state -2V ≤ V _{CANH/L} ≤ +7V	P_8.3.5
Differential Input Resistance	R _{diff}	40	80	100	kΩ	CAN Normal / Wake Capable Mode; Recessive state -2V ≤ V _{CANH/L} ≤ +7V	P_8.3.6
Input Resistance Deviation between CANH and CANL	DR _i	-3	–	3	%	4)Recessive state V _{CANH} = V _{CANL} = 5V	P_8.3.7

High Speed CAN Transceiver

Table 22 Electrical Characteristics (cont'd)

$T_j = -40^\circ\text{C}$ to $+150^\circ\text{C}$; $V_{\text{SINT}} = 5.5\text{ V}$ to 28 V ; $V_{\text{CAN}} = 4.75\text{ V}$ to 5.25 V ; $R_L = 60\ \Omega$; CAN Normal Mode; all voltages with respect to ground, positive current flowing into pin (unless otherwise specified)

Parameter	Symbol	Values			Unit	Note or Test Condition	Number
		Min.	Typ.	Max.			
Input Capacitance CANH, CANL versus GND	C_{in}	–	20	40	pF	¹⁾ $V_{\text{TXDCAN}} = 5\text{ V}$	P_8.3.8
Differential Input Capacitance	C_{diff}	–	10	20	pF	¹⁾ $V_{\text{TXDCAN}} = 5\text{ V}$	P_8.3.9
Wake-up Receiver Threshold Voltage, recessive to dominant edge	$V_{\text{diff,rd}_W}$	–	0.8	1.15	V	$-12\text{ V} \leq V_{\text{CM}}(\text{CAN}) \leq 12\text{ V}$; CAN Wake Capable Mode	P_8.3.10
Wake-up Receiver Dominant state differential input voltage range	$V_{\text{diff,D_range}_W}$	1.15	–	8.0	V	$-12\text{ V} \leq V_{\text{CM}}(\text{CAN}) \leq +12\text{ V}$; CAN Wake Capable Mode	P_8.3.62
Wake-up Receiver Threshold Voltage, dominant to recessive edge	$V_{\text{diff,dr}_W}$	0.4	0.7		V	$-12\text{ V} \leq V_{\text{CM}}(\text{CAN}) \leq 12\text{ V}$; CAN Wake Capable Mode	P_8.3.11
Wake-up Receiver Recessive state differential input voltage range	$V_{\text{diff,R_range}_W}$	-3.0	–	0.4	V	$-12\text{ V} \leq V_{\text{CM}}(\text{CAN}) \leq +12\text{ V}$; CAN Wake Capable Mode	P_8.3.63

CAN Bus Transmitter

CANH/CANL Recessive Output Voltage (CAN Normal Mode)	$V_{\text{CANL/H_NM}}$	2.0	–	3.0	V	CAN Normal Mode $V_{\text{TXDCAN}} = V_{\text{CC1}}$; no load	P_8.3.12
CANH/CANL Recessive Output Voltage (CAN Wake Capable Mode)	$V_{\text{CANL/H_LP}}$	-0.1	–	0.1	V	CAN Wake Capable Mode; $V_{\text{TXDCAN}} = V_{\text{CC1}}$; no load	P_8.3.13
CANH, CANL Recessive Output Voltage Difference $V_{\text{diff}} = V_{\text{CANH}} - V_{\text{CANL}}$ (CAN Normal Mode)	$V_{\text{diff}_r_N}$	-500	–	50	mV	CAN Normal Mode; $V_{\text{TXDCAN}} = V_{\text{CC1}}$; no load	P_8.3.14
CANH, CANL Recessive Output Voltage Difference $V_{\text{diff}} = V_{\text{CANH}} - V_{\text{CANL}}$ (CAN Wake Capable Mode)	$V_{\text{diff}_r_W}$	-200	–	200	mV	CAN Wake Capable Mode; $V_{\text{TXDCAN}} = V_{\text{CC1}}$; no load	P_8.3.15
CANL Dominant Output Voltage	V_{CANL}	0.5	–	2.25	V	⁴⁾ CAN Normal Mode; $V_{\text{TXDCAN}} = 0\text{ V}$; $V_{\text{CAN}} = 5\text{ V}$; $50\ \Omega \leq R_L \leq 65\ \Omega$	P_8.3.16

High Speed CAN Transceiver

Table 22 Electrical Characteristics (cont'd)

$T_j = -40^\circ\text{C}$ to $+150^\circ\text{C}$; $V_{\text{SINT}} = 5.5\text{ V}$ to 28 V ; $V_{\text{CAN}} = 4.75\text{ V}$ to 5.25 V ; $R_L = 60\ \Omega$; CAN Normal Mode; all voltages with respect to ground, positive current flowing into pin (unless otherwise specified)

Parameter	Symbol	Values			Unit	Note or Test Condition	Number
		Min.	Typ.	Max.			
CANH Dominant Output Voltage	V_{CANH}	2.75	–	4.5	V	⁴⁾ CAN Normal Mode; $V_{\text{TXDCAN}} = 0\text{ V}$; $V_{\text{CAN}} = 5\text{ V}$; $50\ \Omega \leq R_L \leq 65\ \Omega$	P_8.3.17
CANH, CANL Dominant Output Voltage Difference $V_{\text{diff}} = V_{\text{CANH}} - V_{\text{CANL}}$	$V_{\text{diff_d_N}}$	1.5	2.0	2.5	V	⁴⁾ CAN Normal Mode; $V_{\text{TXDCAN}} = 0\text{ V}$; $V_{\text{CAN}} = 5\text{ V}$; $50\ \Omega \leq R_L \leq 65\ \Omega$	P_8.3.18
CANH, CANL Dominant Output Voltage Difference (resistance during arbitration) $V_{\text{diff}} = V_{\text{CANH}} - V_{\text{CANL}}$	$V_{\text{diff_d_N}}$	1.5	–	5.0	V	⁴⁾ CAN Normal Mode; $V_{\text{TXDCAN}} = 0\text{ V}$; $V_{\text{CAN}} = 5\text{ V}$; $R_L = 2240\ \Omega$	P_8.3.19
CANH, CANL output voltage difference slope, recessive to dominant	$V_{\text{diff_slope_rd}}$	–	–	70	V/us	⁴⁾ 30% to 70% of measured differential bus voltage, $C_L = 100\text{ pF}$, $R_L = 60\ \Omega$	P_8.3.54
CANH, CANL output voltage difference slope, dominant to recessive	$V_{\text{diff_slope_dr}}$	–	–	70	V/us	⁴⁾ 70% to 30% of measured differential bus voltage, $C_L = 100\text{ pF}$, $R_L = 60\ \Omega$	P_8.3.55
Driver Symmetry $V_{\text{SYM}} = V_{\text{CANH}} + V_{\text{CANL}}$	V_{SYM}	4.5	–	5.5	V	²⁾ CAN Normal Mode; $V_{\text{TXDCAN}} = 0\text{ V} / 5\text{ V}$; $V_{\text{CAN}} = 5\text{ V}$; $C_{\text{SPLIT}} = 4.7\text{ nF}$; $50\ \Omega \leq R_L \leq 60\ \Omega$;	P_8.3.21
CANH Short Circuit Current	I_{CANHsc}	-115	-80	-50	mA	CAN Normal Mode; $V_{\text{CANHshort}} = -3\text{ V}$	P_8.3.22
CANL Short Circuit Current	I_{CANLsc}	50	80	115	mA	CAN Normal Mode; $V_{\text{CANLshort}} = 18\text{ V}$;	P_8.3.23
Leakage Current	$I_{\text{CANH,lk}}$ $I_{\text{CANL,lk}}$	–	5	7.5	μA	$V_S = V_{\text{CAN}} = 0\text{ V}$; $0\text{ V} \leq V_{\text{CANH,L}} \leq 5\text{ V}$; ³⁾ $R_{\text{test}} = 0 / 47\text{k}\Omega$	P_8.3.24
Receiver Output RXDCAN							
High level Output Voltage	$V_{\text{RXDCAN,H}}$	$0.8 \times V_{\text{CC1}}$	–	–	V	CAN Normal Mode; $I_{\text{RXDCAN}} = -2\text{ mA}$	P_8.3.26
Low Level Output Voltage	$V_{\text{RXDCAN,L}}$	–	–	$0.2 \times V_{\text{CC1}}$	V	CAN Normal Mode; $I_{\text{RXDCAN}} = 2\text{ mA}$	P_8.3.27

High Speed CAN Transceiver

Table 22 Electrical Characteristics (cont'd)

$T_j = -40^\circ\text{C}$ to $+150^\circ\text{C}$; $V_{\text{SINT}} = 5.5\text{ V}$ to 28 V ; $V_{\text{CAN}} = 4.75\text{ V}$ to 5.25 V ; $R_L = 60\ \Omega$; CAN Normal Mode; all voltages with respect to ground, positive current flowing into pin (unless otherwise specified)

Parameter	Symbol	Values			Unit	Note or Test Condition	Number
		Min.	Typ.	Max.			
Transmission Input TXDCAN							
High Level Input Voltage Threshold	$V_{\text{TXDCAN,H}}$	–	–	$0.7 \times V_{\text{cc1}}$	V	CAN Normal Mode; recessive state	P_8.3.28
Low Level Input Voltage Threshold	$V_{\text{TXDCAN,L}}$	$0.3 \times V_{\text{cc1}}$	–	–	V	CAN Normal Mode; dominant state	P_8.3.29
TXDCAN Input Hysteresis	$V_{\text{TXDCAN,hys}}$	–	$0.12 \times V_{\text{cc1}}$	–	V	⁴⁾	P_8.3.30
TXDCAN Pull-up Resistance	R_{TXDCAN}	20	50	80	k Ω	–	P_8.3.31
TXDCAN input capacitance	C_{TXDCAN}	–	6	10	pF	⁴⁾	P_8.3.64
CAN Transceiver Enabling Time	$t_{\text{CAN,EN}}$	8	12	18	μs	⁶⁾ CSN = high to first valid transmitted TXDCAN dominant	P_8.3.32
Dynamic CAN-Transceiver Characteristics							
Min. Dominant Time for Bus Wake-up	t_{Wake1}	0.5	–	1.8	μs	$-12\text{ V} \leq V_{\text{CM}}(\text{CAN}) \leq 12\text{ V}$; CAN Wake Capable Mode	P_8.3.33
Wake-up Time-out, Recessive Bus	t_{Wake2}	0.8	–	10	ms	⁶⁾ CAN Wake Capable Mode	P_8.3.34
Loop delay (recessive to dominant)	$t_{\text{LOOP,f}}$	–	150	255	ns	²⁾ CAN Normal Mode; $C_L = 100\text{ pF}$; $R_L = 60\ \Omega$; $V_{\text{CAN}} = 5\text{ V}$; $C_{\text{RXDCAN}} = 15\text{ pF}$	P_8.3.35
Loop delay (dominant to recessive)	$t_{\text{LOOP,r}}$	–	150	255	ns	²⁾ CAN Normal Mode; $C_L = 100\text{ pF}$; $R_L = 60\ \Omega$; $V_{\text{CAN}} = 5\text{ V}$; $C_{\text{RXDCAN}} = 15\text{ pF}$	P_8.3.36
Propagation Delay TXDCAN low to bus dominant	$t_{\text{d(L),T}}$	–	50	140	ns	CAN Normal Mode; $C_L = 100\text{ pF}$; $R_L = 60\ \Omega$; $V_{\text{CAN}} = 5\text{ V}$	P_8.3.37
Propagation Delay TXDCAN high to bus recessive	$t_{\text{d(H),T}}$	–	50	140	ns	CAN Normal Mode; $C_L = 100\text{ pF}$; $R_L = 60\ \Omega$; $V_{\text{CAN}} = 5\text{ V}$	P_8.3.38

High Speed CAN Transceiver

Table 22 Electrical Characteristics (cont'd)

$T_j = -40^\circ\text{C}$ to $+150^\circ\text{C}$; $V_{\text{SINT}} = 5.5\text{ V}$ to 28 V ; $V_{\text{CAN}} = 4.75\text{ V}$ to 5.25 V ; $R_L = 60\ \Omega$; CAN Normal Mode; all voltages with respect to ground, positive current flowing into pin (unless otherwise specified)

Parameter	Symbol	Values			Unit	Note or Test Condition	Number
		Min.	Typ.	Max.			
Propagation Delay bus dominant to RXDCAN low	$t_{d(L),R}$	–	100	–	ns	CAN Normal Mode; $C_L = 100\text{ pF}$; $R_L = 60\ \Omega$; $V_{\text{CAN}} = 5\text{ V}$; $C_{\text{RXDCAN}} = 15\text{ pF}$	P_8.3.39
Propagation Delay bus recessive to RXDCAN high	$t_{d(H),R}$	–	100	–	ns	CAN Normal Mode; $C_L = 100\text{ pF}$; $R_L = 60\ \Omega$; $V_{\text{CAN}} = 5\text{ V}$; $C_{\text{RXDCAN}} = 15\text{ pF}$	P_8.3.40
Received Recessive bit width	$t_{\text{bit(RXD)}}$	400	–	550	ns	CAN Normal Mode; $C_L = 100\text{ pF}$; $R_L = 60\ \Omega$; $V_{\text{CAN}} = 5\text{ V}$; $C_{\text{RXDCAN}} = 15\text{ pF}$; $t_{\text{bit(TXD)}} = 500\text{ ns}$; Parameter definition in according to Figure 35 .	P_8.3.42
Transmitted Recessive bit width	$t_{\text{bit(BUS)}}$	435	–	530	ns	CAN Normal Mode; $C_L = 100\text{ pF}$; $R_L = 60\ \Omega$; $V_{\text{CAN}} = 5\text{ V}$; $C_{\text{RXDCAN}} = 15\text{ pF}$; $t_{\text{bit(TXD)}} = 500\text{ ns}$; Parameter definition in according to Figure 35 .	P_8.3.43
Receiver timing symmetry ⁵⁾	Δt_{Rec}	-65	–	40	ns	CAN Normal Mode; $C_L = 100\text{ pF}$; $R_L = 60\ \Omega$; $V_{\text{CAN}} = 5\text{ V}$; $C_{\text{RXDCAN}} = 15\text{ pF}$; $t_{\text{bit(TXD)}} = 500\text{ ns}$; Parameter definition in according to Figure 35 .	P_8.3.44

High Speed CAN Transceiver

Table 22 Electrical Characteristics (cont'd)

$T_j = -40^\circ\text{C}$ to $+150^\circ\text{C}$; $V_{\text{SINT}} = 5.5\text{ V}$ to 28 V ; $V_{\text{CAN}} = 4.75\text{ V}$ to 5.25 V ; $R_L = 60\ \Omega$; CAN Normal Mode; all voltages with respect to ground, positive current flowing into pin (unless otherwise specified)

Parameter	Symbol	Values			Unit	Note or Test Condition	Number
		Min.	Typ.	Max.			
Received Recessive bit width	$t_{\text{bit(RXD)}}$	120	–	220	ns	CAN Normal Mode; $C_L = 100\text{ pF}$; $R_L = 60\ \Omega$; $V_{\text{CAN}} = 5\text{ V}$; $C_{\text{RXDCAN}} = 15\text{ pF}$; $t_{\text{bit(TXD)}} = 200\text{ ns}$; Parameter definition in according to Figure 35 .	P_8.3.45
Transmitted Recessive bit width	$t_{\text{bit(BUS)}}$	155	–	210	ns	CAN Normal Mode; $C_L = 100\text{ pF}$; $R_L = 60\ \Omega$; $V_{\text{CAN}} = 5\text{ V}$; $C_{\text{RXDCAN}} = 15\text{ pF}$; $t_{\text{bit(TXD)}} = 200\text{ ns}$; Parameter definition in according to Figure 35 .	P_8.3.46
Receiver timing symmetry $\Delta t_{\text{Rec}} = t_{\text{bit(RXD)}} - t_{\text{bit(BUS)}}$	Δt_{Rec}	-45	–	15	ns	CAN Normal Mode; $C_L = 100\text{ pF}$; $R_L = 60\ \Omega$; $V_{\text{CAN}} = 5\text{ V}$; $C_{\text{RXDCAN}} = 15\text{ pF}$; $t_{\text{bit(TXD)}} = 200\text{ ns}$; Parameter definition in according to Figure 35 .	P_8.3.47
TXDCAN Permanent Dominant Time-out	$t_{\text{TXDCAN_TO}}$	1.6	2.0	2.4	ms	⁶⁾ CAN Normal Mode	P_8.3.48
BUS Permanent Dominant Time-out	$t_{\text{BUS_CAN_TO}}$	2.0	2.5	3.0	ms	⁶⁾ CAN Normal Mode	P_8.3.49
Timeout for bus inactivity	t_{SILENCE}	0.6	–	1.2	s	⁶⁾	P_8.3.50
Bus Bias reaction time	t_{Bias}	–	–	250	μs	⁶⁾	P_8.3.51

- 1) Not subject to production test, specified by design, S2P - Method; $f = 10\text{ MHz}$
- 2) V_{SYM} shall be observed during dominant and recessive state and also during the transition dominant to recessive and vice versa while TXD is simulated by a square signal (50% duty cycle) with a frequency of up to 1 MHz (2MBit/s).
- 3) R_{tests} between (V_s / V_{CAN}) and 0V (GND).
- 4) Not subject to production test, specified by design.
- 5) $\Delta t_{\text{Rec}} = t_{\text{bit(RXD)}} - t_{\text{bit(BUS)}}$.
- 6) Not subject to production test, tolerance defined by internal oscillator tolerance.

High Speed CAN Transceiver

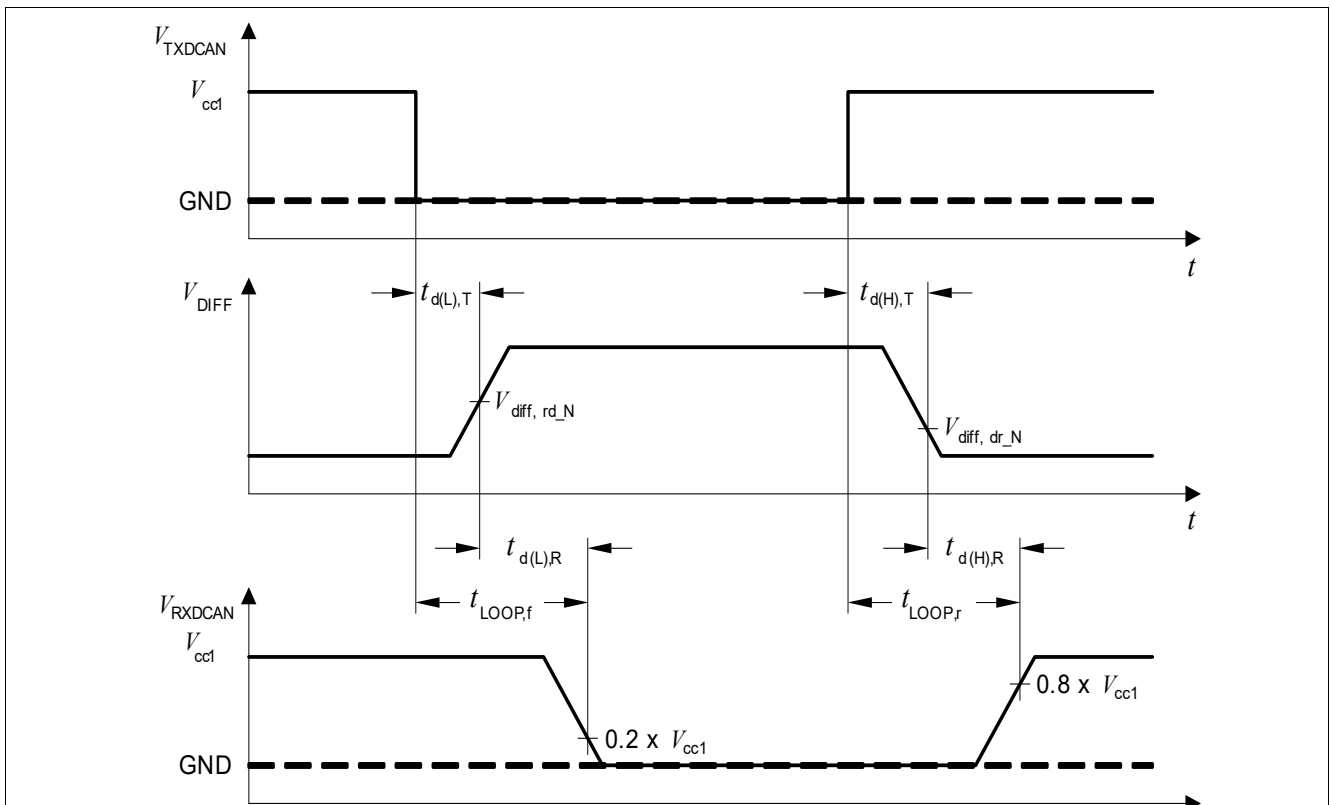

Figure 34 Timing Diagrams for Dynamic Characteristics

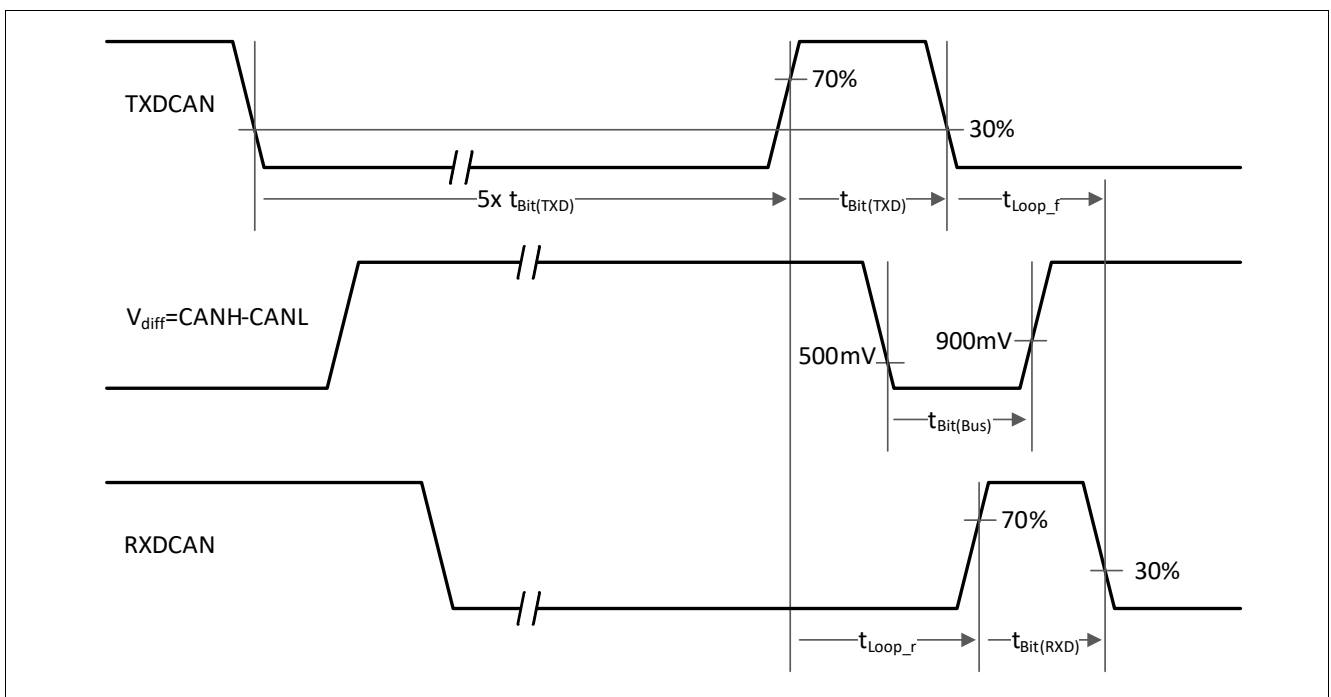

Figure 35 From ISO11898-2:2016: tloop, tbit(TXD), tbit(Bus), tbit(RXD) definitions

9 LIN Transceiver

9.1 Block Description

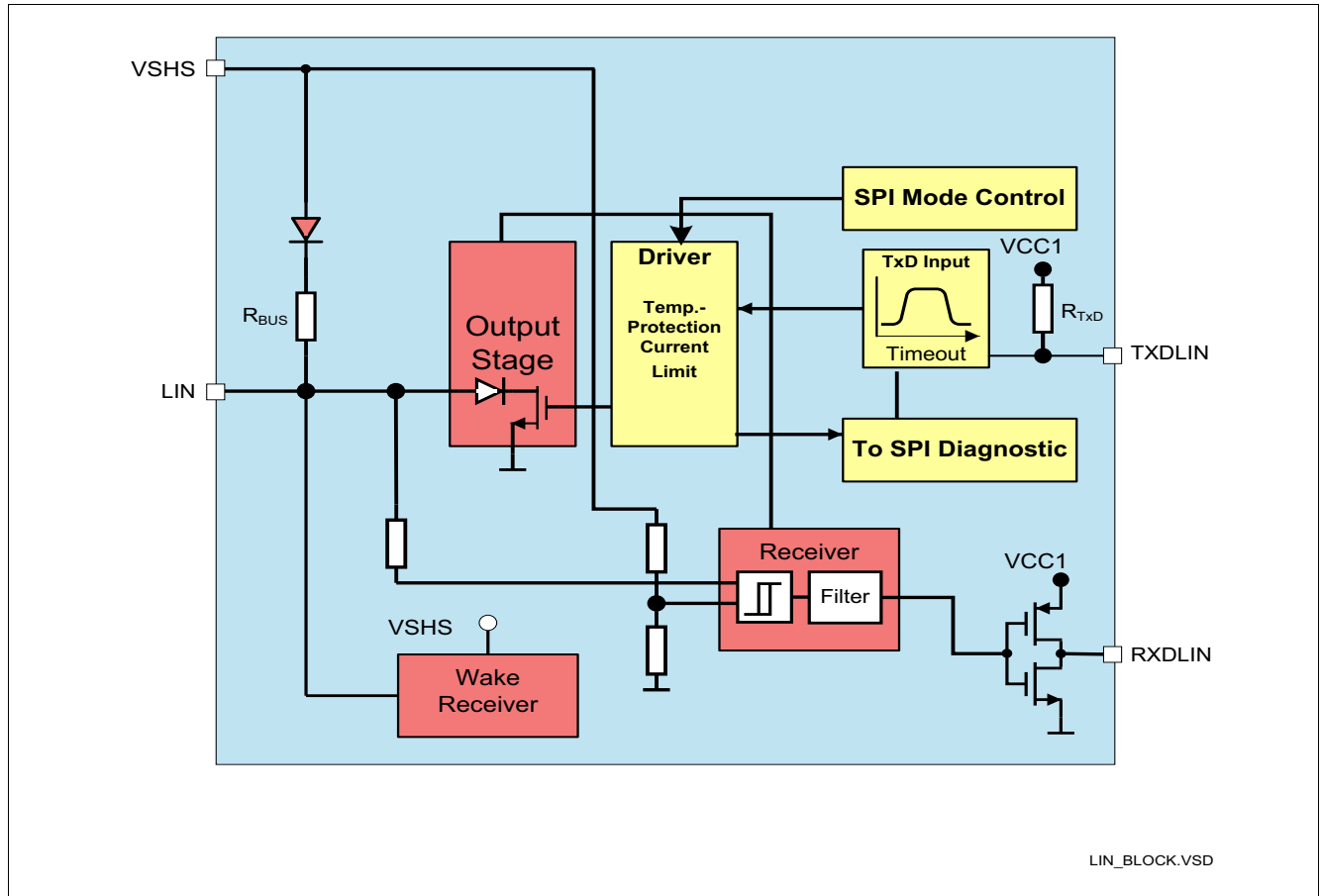

Figure 36 Block Diagram

9.1.1 LIN Specifications

The LIN network is standardized by international regulations.

The device is compliant to:

- ISO17987-4: rev. 2016
- SAE-J2602-2

LIN Transceiver

9.2 Functional Description

The LIN Bus is a single wire, bi-directional bus, used for in-vehicle networks. The LIN transceivers implemented inside the TLE9562-3QX are the interface between the microcontroller and the physical LIN Bus. The digital output data from the microcontroller are driven to the LIN bus via the TXDLIN pin on the TLE9562-3QX. The transmit data stream on the TXDLIN is converted to a LIN bus signal with optimized slew rate to minimize the EME level of the LIN network. The RXDLIN sends back the information from the LIN bus to the microcontroller. The receiver has an integrated filter network to suppress noise on the LIN Bus and to increase the EMI (Electro Magnetic Immunity) level of the transceiver.

Two logical states are possible on the LIN Bus according to the LIN specification.

Every LIN network consists of a master node and one or more slave nodes. To configure the TLE9562-3QX for master node applications, a resistor in the range of 1 kΩ and a reverse diode must be connected between the LIN bus and the power supply VSHS.

The different transceiver modes can be controlled via the SPI LIN bits.

Figure 37 shows the possible transceiver mode transitions when changing the devicemode.

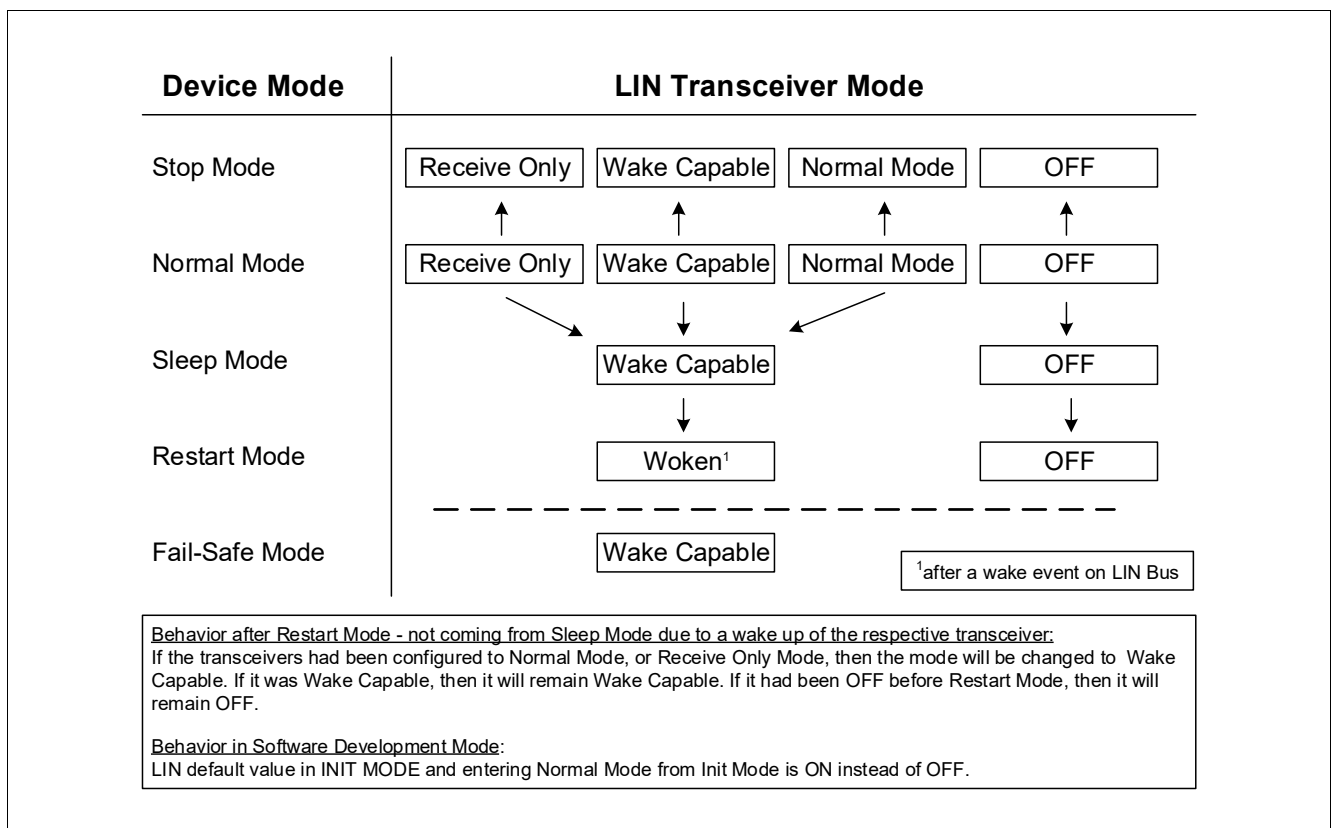

Figure 37 LIN Mode Control Diagram

9.2.1 LIN OFF Mode

The LIN OFF Mode is the default mode after power-up of the device. It is available in all device modes and is intended to completely stop LIN activities or when LIN communication is not needed. In LIN OFF Mode, a wake-up event on the bus will be ignored.

9.2.2 LIN Normal Mode

The LIN Transceiver is enabled via SPI in Normal Mode. LIN Normal Mode is designed for normal data transmission/reception within the LIN network. The mode is available in Normal Mode and in Stop Mode.

LIN Transceiver

Transmission

The signal from the microcontroller is applied to the TXDLIN input of the device. The bus driver switches the LIN output stage to transfer this input signal to the LIN bus line.

Enabling Sequence

The LIN transceiver requires an enabling time $t_{LIN,EN}$ before a message can be sent on the bus. This means that the TXDLIN signal can only be pulled LOW after the enabling time. If this is not ensured, then the TXDLIN needs to be set back to high (=recessive) until the enabling time is completed.

Only the next dominant bit will be transmitted on the bus.

Figure 38 shows different scenarios and explanations for LIN enabling.

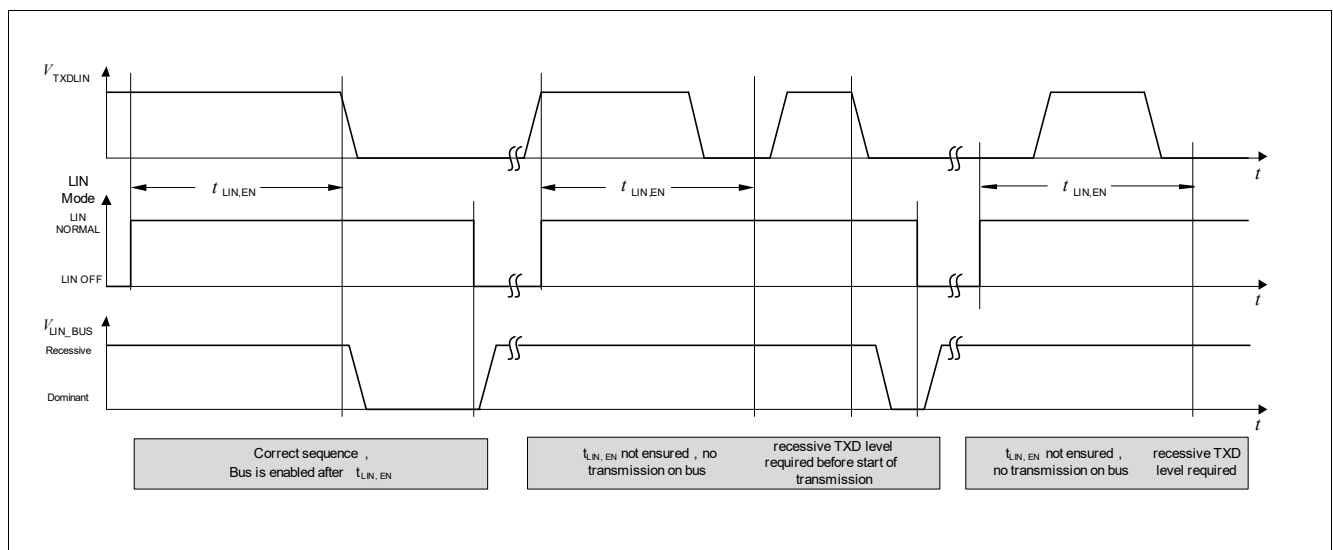

Figure 38 LIN Transceiver Enabling Sequence

Reduced Electromagnetic Emission

To reduce electromagnetic emissions (EME), the bus driver controls LIN slopes symmetrically. The configuration of the different slopes is described in **Chapter 9.2.8**.

Reception

Analog LIN bus signals are converted into digital signals at RXDLIN via the differential input receiver.

9.2.3 LIN Receive Only Mode

In LIN Receive Only Mode (RXD only), the driver stage is de-activated but reception is still possible. This mode is accessible by an SPI command and is available in Normal Mode and Stop Mode.

9.2.4 LIN Wake Capable Mode

This mode can be used in Stop Mode, Sleep Mode, Restart Mode and Normal Mode by programming via SPI and it is used to monitor bus activities. It is automatically accessed in Fail-Safe Mode. A wake up is detected, if a recessive to dominant transition on the LIN bus is followed by a dominant level of longer than $t_{WK,Bus}$ followed by a dominant to recessive transition. The dominant to recessive transition will cause a wake up of the LIN transceiver.

LIN Transceiver

A wake-up results in different behavior of the device, as described in below [Table 23](#). As a signalization to the microcontroller, the RXDLIN pin is set LOW and will stay LOW until the LIN transceiver is changed to any other mode. After a wake-up event the transceiver can be switched to LIN Normal Mode for communication.

Table 23 Action due to a LIN BUS Wake-up

Mode	Mode after Wake	VCC1	INTN	RXDLIN
Normal Mode	Normal Mode	ON	LOW	LOW
Stop Mode	Stop Mode	ON	LOW	LOW
Sleep Mode	Restart Mode	Ramping Up	HIGH	LOW
Restart Mode	Restart Mode	ON	HIGH	LOW
Fail-Safe Mode	Restart Mode	Ramping up	HIGH	LOW

Rearming the transceiver for wake capability

After a BUS wake-up event, the transceiver is woken. However, the LIN transceiver mode bits will still show wake capable (=‘01’) so that the RXDLIN signal will be pulled low.

There are two possibilities how the LIN transceiver’s wake capable mode is enabled again after a wake event:

- The LIN transceiver mode must be toggled, i.e. switched to LIN Normal Mode, LIN Receive Only Mode or LIN OFF Mode, before switching to LIN Wake Capable Mode again.
- Rearming is done automatically when the device is changed to Stop Mode, Sleep Mode or Fail-Safe Mode to ensure wake-up capability.

Wake-Up in Stop Mode and Normal Mode

In Stop Mode, if a wake-up is detected, it is signaled by the INTN output and in the [WK_STAT](#) SPI register. It is also signaled by RXDLIN put to LOW. The same applies for the Normal Mode. The microcontroller should set the device to Normal Mode, there is no automatic transition to Normal Mode.

For functional safety reasons, the watchdog will be automatically enabled in Stop Mode after a Bus wake event in case it was disabled before (if bit [WD_EN_WK_BUS](#) was configured to HIGH before).

Wake-Up in Sleep Mode

One wake-up event on the LIN Bus from Sleep or Fail-Safe Mode automatically transfers the device into the Restart Mode and from there to Normal Mode. The corresponding RXD pin in set to LOW. The microcontroller is able to detect the low signal on RXD and to read the wake source out of the [WK_STAT](#) register via SPI. No interrupt is generated when coming out of Sleep or Fail-Safe Mode. The microcontroller can now switch the LIN transceiver into LIN Normal Mode via SPI to start communication.

9.2.5 TXD Time-out Feature

If the TXDLIN signal is dominant for the time $t > t_{TXD_LIN_TO}$, the TXD time-out function deactivates the LIN transmitter output stage temporarily. The transceiver remains in recessive state. The TXD time-out function prevents the LIN bus from being blocked by a permanent LOW signal on the TXDLIN pin, caused by a failure. The failure is stored in the SPI flag [LIN_FAIL](#). The LIN transmitter stage is activated again after the dominant time-out condition is removed. The transceiver configuration stays unchanged.

LIN Transceiver

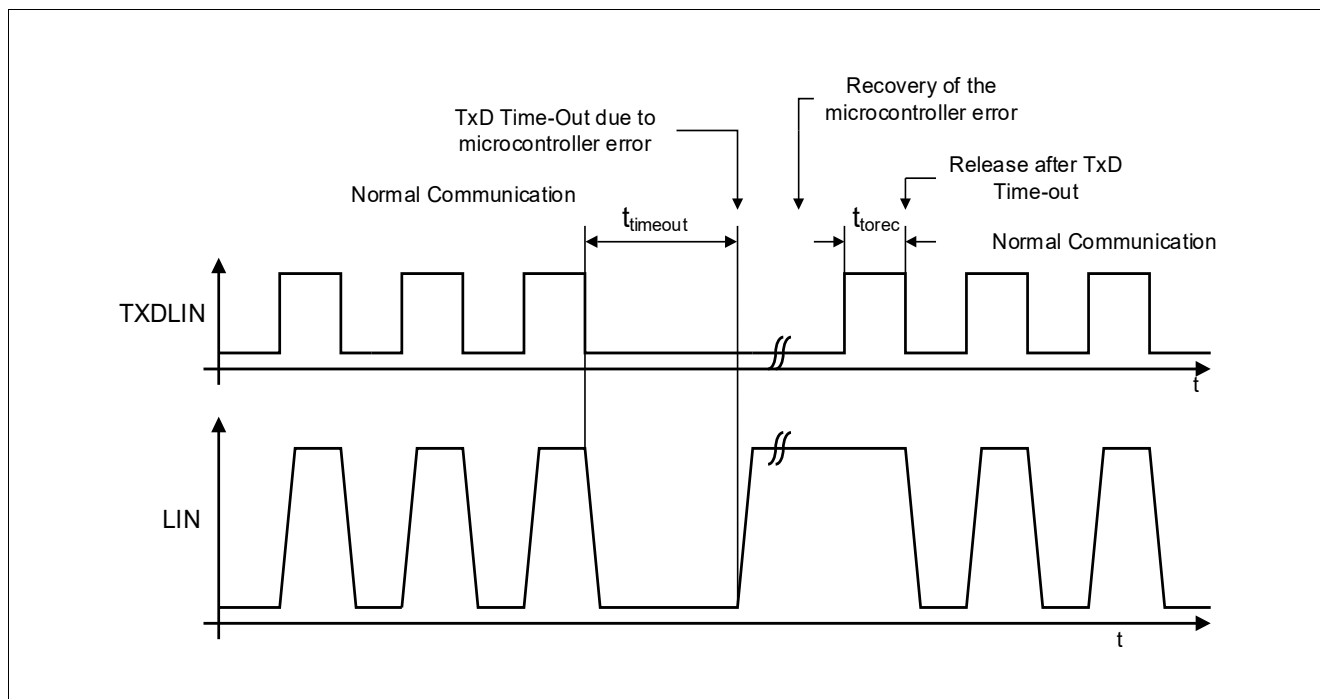

Figure 39 TXD Time-Out Function

9.2.6 Bus Dominant Clamping

If the LIN bus signal is dominant for a time $t > t_{BUS_LIN_TO}$ in LIN Normal Mode and LIN Receive Only Mode, then a bus dominant clamping is detected and the SPI bit **LIN_FAIL** is set. The transceiver configuration stays unchanged.

9.2.7 Under-Voltage Detection

In case the supply voltage is dropping below the VSHS undervoltage detection threshold ($V_{SHS} < V_{SHS,UV D}$), the TLE9562-3QX disables the output and receiver stages. If the power supply reaches a higher level than the undervoltage detection threshold ($V_{SHS} > V_{SHS,UV D}$), the TLE9562-3QX continues with normal operation. The transceiver configuration stays unchanged.

9.2.8 Slope Selection

The LIN transceiver offers a LIN Low-Slope Mode for 10.4 kBaud communication and a LIN Normal-Slope Mode for 20 kBaud communication. The only difference is the behavior of the transmitter. In LIN Low-Slope Mode, the transmitter uses a lower slew rate to further reduce the EME compared to Normal-Slope Mode. This complies with SAE J2602 requirements. By default, the device works in LIN Normal-Slope Mode. The selection of LIN Low-Slope Mode is done by an SPI bit **LIN_LSM** and will become effective as soon as CSN goes 'HIGH'. Only the LIN Slope is changed. The selection is accessible in Normal Mode only.

9.2.9 Flash Programming via LIN

The device allows LIN flash programming, e.g. of another LIN Slave with a communication of up to 115 kBaud. This feature is enabled by de-activating the slope control mechanism via a SPI command (bit **LIN_FLASH**) and will become effective as soon as CSN goes 'HIGH'. The SPI bit can be set in Normal Mode.

Note: It is recommended to perform flash programming only at nominal supply voltage $V_{SHS} = 13.5 V$ to ensure stable data communication.

LIN Transceiver

9.3 Electrical Characteristics

Table 24 Electrical Characteristics

$V_{SHS} = 5.5\text{ V to }18\text{ V}$, $T_j = -40^\circ\text{C to }+150^\circ\text{C}$, $R_L = 500\ \Omega$, all voltages with respect to ground, positive current flowing into pin (unless otherwise specified)

Parameter	Symbol	Values			Unit	Note or Test Condition	Number
		Min.	Typ.	Max.			
Receiver Output (RXD pin)							
HIGH Level Output Voltage	$V_{RXD,H}$	$0.8 \times V_{CC1}$	–	–	V	$I_{RXD} = -2\text{ mA}$; $V_{Bus} = V_{SHS}$	P_9.3.1
LOW Level Output Voltage	$V_{RXD,L}$	–	–	$0.2 \times V_{CC1}$	V	$I_{RXD} = 2\text{ mA}$; $V_{Bus} = 0\text{ V}$	P_9.3.2
Transmission Input (TXD pin)							
HIGH Level Input Voltage	$V_{TXD,H}$	–	–	$0.7 \times V_{CC1}$	V	Recessive State	P_9.3.3
TXD Input Hysteresis	$V_{TXD,hys}$	–	$0.12 \times V_{CC1}$	–	V	¹⁾	P_9.3.4
LOW Level Input Voltage	$V_{TXD,L}$	$0.3 \times V_{CC1}$	–	–	V	Dominant State	P_9.3.5
TXD Pull-up Resistance	R_{TXD}	20	40	80	k Ω	$V_{TXD} = 0\text{ V}$	P_9.3.6
LIN Bus Receiver (LIN Pin)							
Receiver Threshold Voltage, Recessive to Dominant Edge	$V_{Bus,rd}$	$0.4 \times V_{SHS}$	$0.45 \times V_{SHS}$	–	V		P_9.3.7
Receiver Dominant State	$V_{Bus,dom}$	–	–	$0.4 \times V_{SHS}$	V	LIN 2.2 Param. 17	P_9.3.8
Receiver Threshold Voltage, Dominant to Recessive Edge	$V_{Bus,dr}$	–	$0.55 \times V_{SHS}$	$0.60 \times V_{SHS}$	V		P_9.3.9
Receiver Recessive State	$V_{Bus,rec}$	$0.6 \times V_{SHS}$	–	–	V	LIN 2.2 Param 18	P_9.3.10
Receiver Center Voltage	$V_{Bus,c}$	$0.475 \times V_{SHS}$	$0.5 \times V_{SHS}$	$0.525 \times V_{SHS}$	V	LIN 2.2 Param 19 $6\text{ V} < V_{SHS} < 18\text{ V}$	P_9.3.11
Receiver Hysteresis	$V_{Bus,hys}$	$0.07 \times V_{SHS}$	$0.1 \times V_{SHS}$	$0.175 \times V_{SHS}$	V	$V_{bus,hys} = V_{bus,dr} - V_{bus,rd}$ LIN 2.2 Param 20	P_9.3.12
Wake-up Threshold Voltage	$V_{Bus,wk}$	$0.40 \times V_{SHS}$	$0.5 \times V_{SHS}$	$0.6 \times V_{SHS}$	V	–	P_9.3.13
Dominant Time for Bus Wake-up	$t_{WK,Bus}$	30	–	150	μs	²⁾	P_9.3.14

LIN Transceiver

Table 24 Electrical Characteristics (cont'd)

$V_{SHS} = 5.5\text{ V to }18\text{ V}$, $T_j = -40^\circ\text{C to }+150^\circ\text{C}$, $R_L = 500\ \Omega$, all voltages with respect to ground, positive current flowing into pin (unless otherwise specified)

Parameter	Symbol	Values			Unit	Note or Test Condition	Number
		Min.	Typ.	Max.			
LIN Bus Transmitter (LIN Pin)							
Bus Serial Diode Voltage Drop	$V_{serdiode}$	0.4	0.7	1.0	V	¹⁾ $V_{TXD} = V_{CC1}$; LIN 2.2 Param 21	P_9.3.15
Bus Recessive Output Voltage	$V_{BUS,ro}$	$0.8 \times V_{SHS}$	–	V_{SHS}	V	$V_{TXD} = \text{HIGH Level}$	P_9.3.16
Bus Short Circuit Current	$I_{BUS,sc}$	40	100	150	mA	$V_{BUS} = 18\text{ V}$; LIN 2.2 Param 12	P_9.3.20
Leakage Current Loss of Ground	$I_{BUS,lk1}$	-1000	-450	20	μA	$V_{SHS} = 12\text{ V} = \text{GND}$; $0\text{ V} < V_{BUS} < 18\text{ V}$; LIN 2.2 Param 15	P_9.3.21
Leakage Current Loss of Battery	$I_{BUS,lk2}$	–	–	20	μA	$V_{SHS} = 0\text{ V}$; $V_{BUS} = 18\text{ V}$; LIN 2.2 Param 16	P_9.3.22
Leakage Current Driver Off	$I_{BUS,lk3}$	-1	–	–	mA	$V_{SHS} = 18\text{ V}$; $V_{BUS} = 0\text{ V}$; LIN 2.2 Param 13	P_9.3.23
Leakage Current Driver Off	$I_{BUS,lk4}$	–	–	20	μA	$V_{SHS} = 8\text{ V}$; $V_{BUS} = 18\text{ V}$; LIN 2.2 Param 14	P_9.3.24
Bus Pull-up Resistance	R_{BUS}	20	30	47	k Ω	Normal Mode LIN 2.2 Param 26	P_9.3.25
LIN Input Capacitance	C_{BUS}		20	25	pF	¹⁾	P_9.3.26
Receiver propagation delay bus dominant to RXD LOW	$t_{d(L),R}$	–	1	6	μs	$V_{CC} = 5\text{ V}$; $C_{RXD} = 20\text{ pF}$; LIN 2.2 Param 31	P_9.3.27
Receiver propagation delay bus recessive to RXD HIGH	$t_{d(H),R}$	–	1	6	μs	$V_{CC} = 5\text{ V}$; $C_{RXD} = 20\text{ pF}$; LIN 2.2 Param 31	P_9.3.28
Receiver delay symmetry	$t_{sym,R}$	-2	–	2	μs	$t_{sym,R} = t_{d(L),R} - t_{d(H),R}$; LIN 2.2 Param 32	P_9.3.29
LIN Transceiver Enabling Time	$t_{LIN,EN}$	8	13	18	μs	²⁾ CSN = HIGH to first valid transmitted TXD dominant	P_9.3.30
Bus Dominant Time Out	$t_{BUS_LIN_TO}$	–	20	–	ms	¹⁾²⁾	P_9.3.31
TXD Dominant Time Out	$t_{TXD_LIN_TO}$	–	20	–	ms	¹⁾²⁾ $V_{TXD} = 0\text{ V}$	P_9.3.32
TXD Dominant Time Out Recovery Time	t_{torec}	–	10	–	μs	¹⁾²⁾	P_9.3.33

LIN Transceiver

Table 24 Electrical Characteristics (cont'd)

$V_{SHS} = 5.5\text{ V to }18\text{ V}$, $T_j = -40^\circ\text{C to }+150^\circ\text{C}$, $R_L = 500\ \Omega$, all voltages with respect to ground, positive current flowing into pin (unless otherwise specified)

Parameter	Symbol	Values			Unit	Note or Test Condition	Number
		Min.	Typ.	Max.			
Duty Cycle D1 (For worst case at 20 kbit/s) LIN 2.2 Normal Slope	D1	0.396	–	–		³⁾ $TH_{Rec}(max) = 0.744 \times V_{SHS}$; $TH_{Dom}(max) = 0.581 \times V_{SHS}$; $V_{SHS} = 7.0 \dots 18\text{ V}$; $t_{bit} = 50\ \mu\text{s}$; $D1 = t_{bus_rec(min)}/2 t_{bit}$; LIN 2.2 Param 27	P_9.3.34
Duty Cycle D2 (for worst case at 20 kbit/s) LIN 2.2 Normal Slope	D2	–	–	0.581		³⁾ $TH_{Rec}(min.) = 0.422 \times V_{SHS}$; $TH_{Dom}(min.) = 0.284 \times V_{SHS}$; $V_{SHS} = 7.6 \dots 18\text{ V}$; $t_{bit} = 50\ \mu\text{s}$; $D2 = t_{bus_rec(max)}/2 t_{bit}$; LIN 2.2 Param 28	P_9.3.35
Duty Cycle D3 (for worst case at 10.4 kbit/s) SAE J2602 Low Slope	D3	0.417	–	–		³⁾ $TH_{Rec}(max) = 0.778 \times V_{SHS}$; $TH_{Dom}(max) = 0.616 \times V_{SHS}$; $V_{SHS} = 7.0 \dots 18\text{ V}$; $t_{bit} = 96\ \mu\text{s}$; $D3 = t_{bus_rec(min)}/2 t_{bit}$; LIN 2.2 Param 29	P_9.3.36
Duty Cycle D4 (for worst case at 10.4 kbit/s) SAE J2602 Low Slope	D4	–	–	0.590		³⁾ $TH_{Rec}(min.) = 0.389 \times V_{SHS}$; $TH_{Dom}(min.) = 0.251 \times V_{SHS}$; $V_{SHS} = 7.6 \dots 18\text{ V}$; $t_{bit} = 96\ \mu\text{s}$; $D4 = t_{bus_rec(max)}/2 t_{bit}$; LIN 2.2 Param 30	P_9.3.37

- 1) Not subject to production test, specified by design.
- 2) Not subject to production test, tolerance defined by internal oscillator tolerance.
- 3) Bus load conditions concerning LIN Specification 2.2 C_{LIN} , $R_{LIN} = 1\text{ nF}$, $1\text{ k}\Omega$ / 6.8 nF , $660\ \Omega$ / 10 nF , $500\ \Omega$.

LIN Transceiver

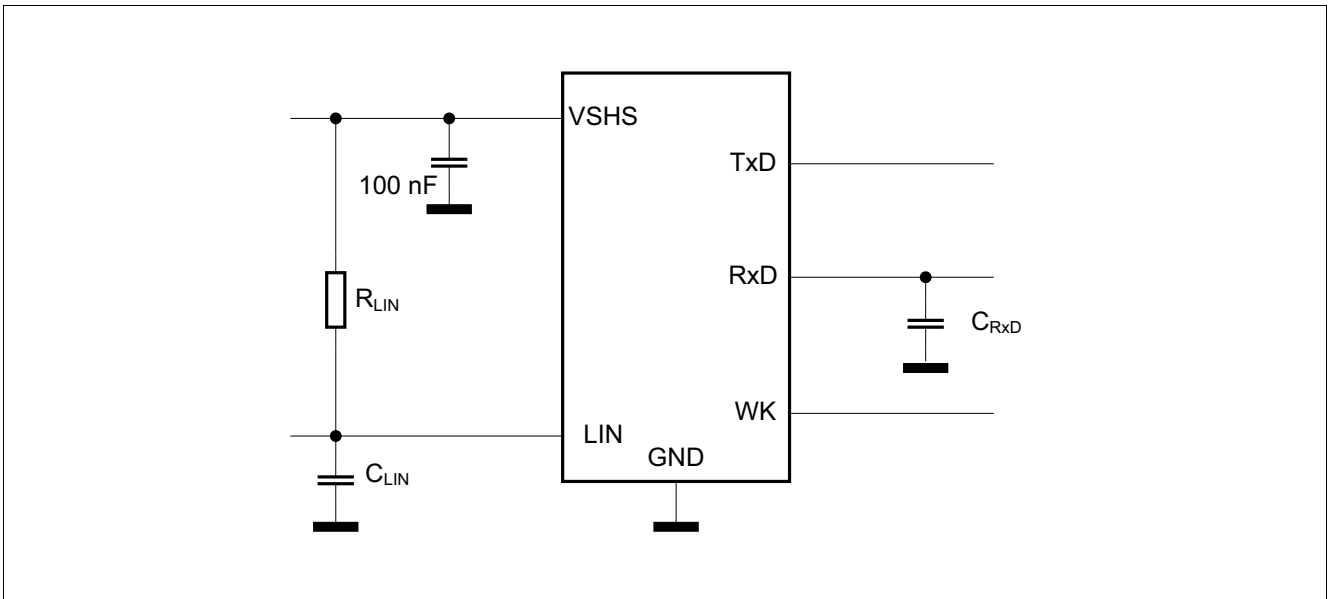

Figure 40 Simplified Test Circuit for Dynamic Characteristics

LIN Transceiver

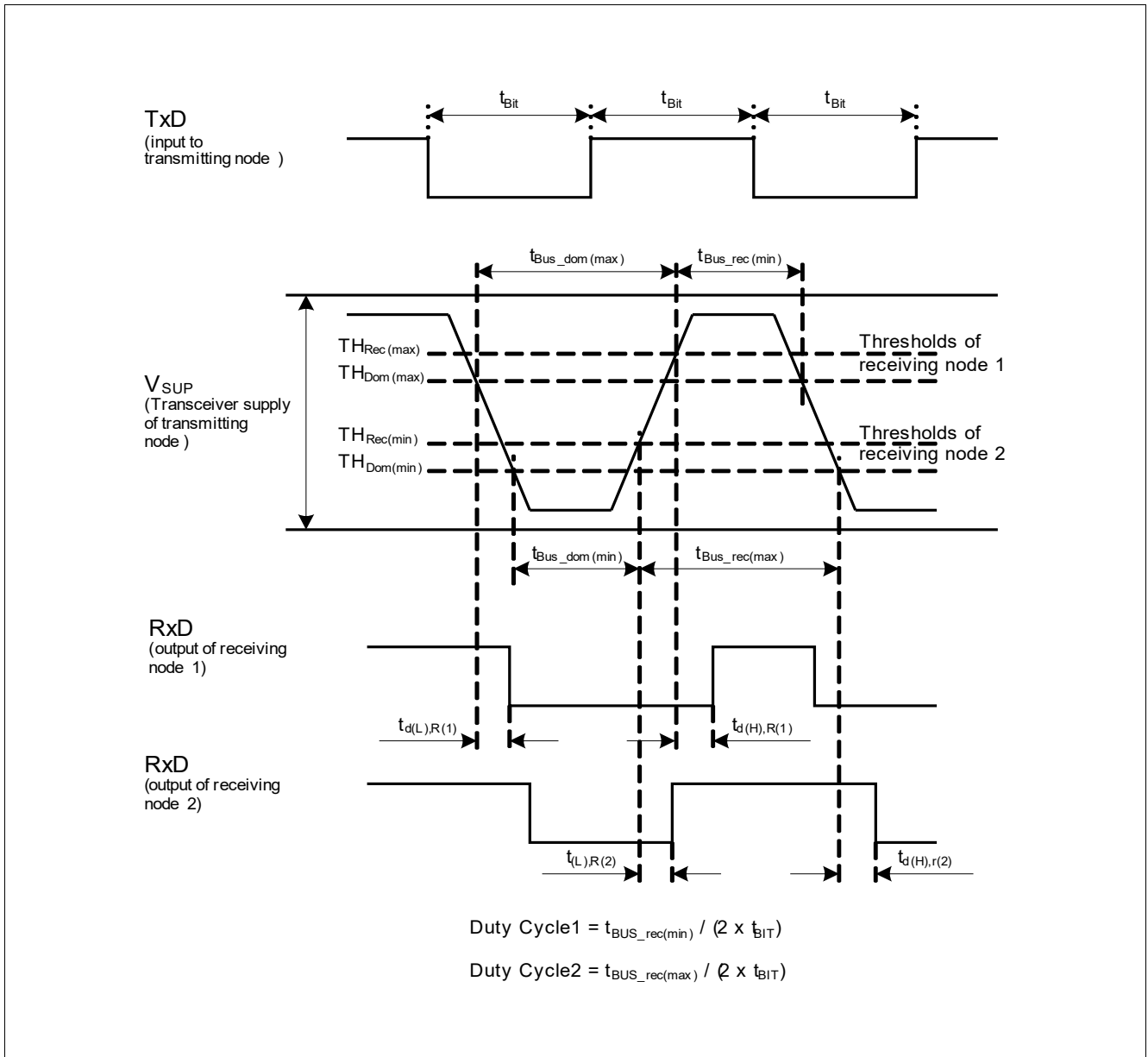

Figure 41 Timing Diagram for Dynamic Characteristics

10 High-Voltage Wake Input

10.1 Block Description

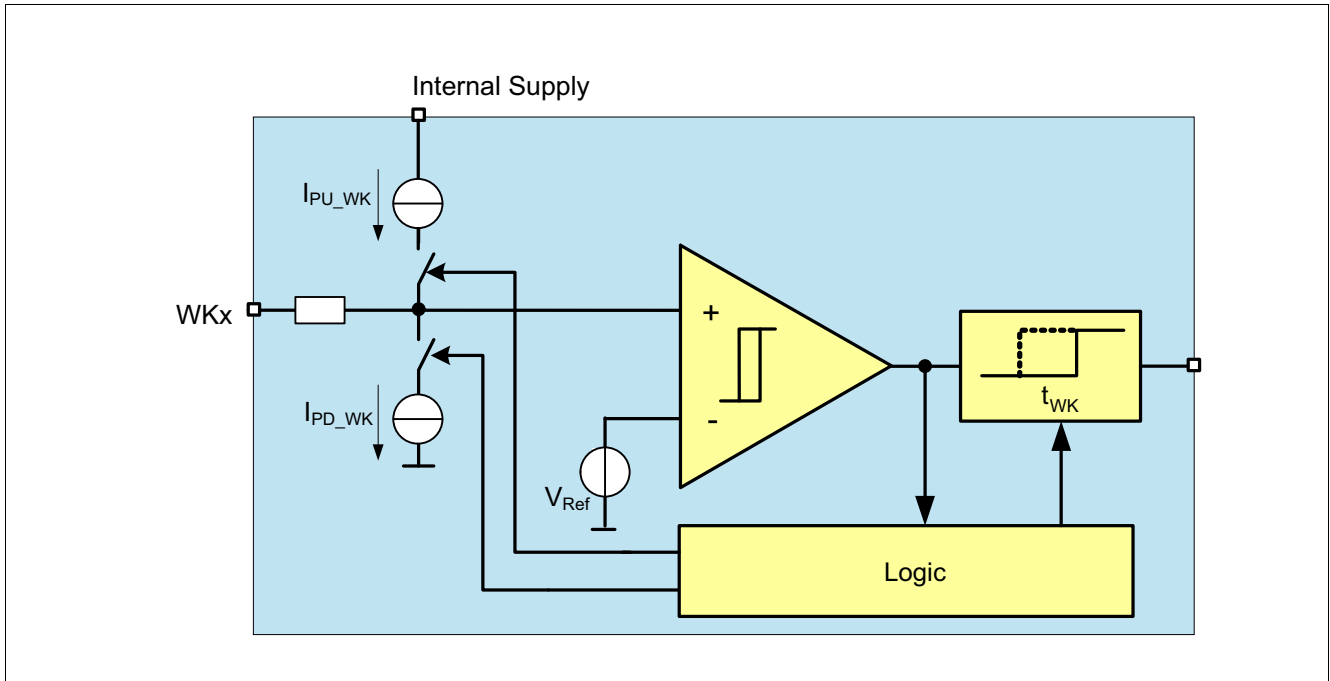

Figure 42 Wake Input Block Diagram

Features

- High-Voltage inputs with a 3 V (typ.) threshold voltage.
- Wake-up capability for power saving modes.
- Edge sensitive wake feature low to high and high to low.
- Pull-up and Pull-down current sources, configurable via SPI.
- Selectable configuration for static sense or cyclic sense.
- In Normal Mode and Stop Mode the level of the WKx pin can be read via SPI unless WK4 is configured as SYNC or WK2 is configured as FO.
- Synchronization with HSx via WK4 (for cyclic sense).
- Fail Safe Output configurability (only WK2).

High-Voltage Wake Input

10.2 High-Voltage Wake Function

10.2.1 Functional Description

The wake inputs pin are edge-sensitive inputs with a switching threshold of typically 3 V. Both transitions, high to low and low to high, result in a signalization by the device. The signalization occurs either in triggering the interrupt in Normal Mode and Stop Mode or by a wake up of the device in Sleep Mode and Fail-Safe Mode.

Two different wake detection modes can be selected via SPI:

- Static sense: WK inputs are always active.
- Cyclic sense: WK inputs are only active for a certain time period (see [Chapter 5.7.1](#)).

A filter time t_{FWKx} is implemented to avoid an unintentional wake-up due to transients or EMC disturbances in static sense configuration.

The filter time (t_{FWKx}) is triggered by a level change crossing the switching threshold and a wake signal is recognized if the input level will not cross again the threshold during the selected filter time.

[Figure 43](#) shows a typical wake-up timing and filtering of transient pulses.

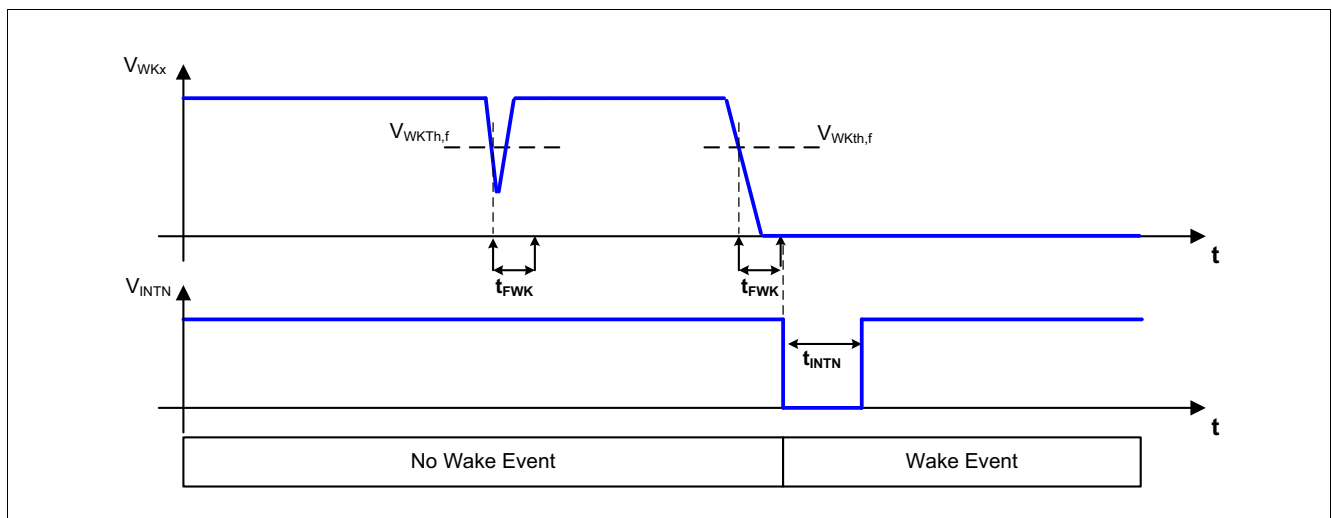

Figure 43 Wake-up Filter Timing for Static Sense

The wake-up capability for the WKx pin can be enabled or disabled via SPI command.

A wake event via the WKx pin can always be read in the register [WK_STAT](#).

The actual voltage level of the WKx pin (low or high) can always be read in Normal Mode, Stop Mode and Init Mode in the register [WK_LVL_STAT](#). During Cyclic Sense, the register shows the sampled levels of the respective WKx pin.

10.2.2 Wake Input Configuration

To ensure a defined and stable voltage levels at the internal comparator input it is possible to configure integrated current sources via the SPI register [WK_CTRL](#).

High-Voltage Wake Input

Table 25 Pull-Up / Pull-Down Resistor

WKx_PUPD_ 1	WKx_PUPD_ 0	Current Sources	Note
0	0	no current source	WK input is floating if left open (default setting)
0	1	pull-down	WK input internally pulled to GND
1	0	pull-up	WK input internally pulled to internal 5V supply
1	1	Automatic switching	If a high level is detected at the WK input the pull-up source is activated, if low level is detected the pull down is activated.

Note: If a WK input is not used, the respective WK input must be tied to GND on board to avoid unintended floating state of the pin.

One additional configuration is related the filter time of each Wake-up module. The bits **WK_FILT** permit to set the filter time in static sensing or in cyclic sensing.

Note: When the device mode is changed to normal (from INIT), in case of static sense, if the WK pin is set, the WK_STAT register is set in this time (also the interrupt pin).

10.2.3 Wake configuration for Cyclic Sense

The wake-up inputs can also be used for cyclical sensing signals during low-power modes. For this function the WKx input performs a cyclic sensing of the voltage level during the on-time of specific HSx.

A transition of the voltage level will trigger a wake-up event.

See also [Chapter 5.7.1](#) for more details.

10.2.4 Wake configuration for Synchronization

The WK4 pin can be configured as SYNC input for driving the HSx.

Prerequisite to configure the WK4 as SYNC input is that the WK4 has to be OFF.

The configuration of the WK4/SYNC bit is done using the **WK_EN** bits. if the **WK_EN**=10_B (SYNC selected), all bits in WK4 bank are ignored and wake-up capability on WK4 is not available.

Note: If WKx is the only wake source available and is configured with cyclic sense with SYNC (WKx_FILT = 100), trying to go to Sleep Mode is not possible (restart mode is entered) - because SYNC is driven by the microcontroller which is not supplied in Sleep Mode.

10.2.5 Fail Safe Output Configuration

The WK2 is by default configured as Fail Safe Output. It is possible to configure the WK2/FO pin as wake-up source using the **WK2_FO** bit.

As soon as the bit **WK2_FO** is written (first SPI write access of bank 2 on **WK_CTRL**), the configuration can be changed only after a software reset or a new power-up sequence.

In case that the **WK2_FO** is locked, any attempt to configured again it will set the **SPI_FAIL**.

The Fail Output consists of a failure logic block and one LOW-side switch. In case of a failure, the FO output is activated and the SPI bit **FAILURE**, in the register **DEV_STAT**, is set.

The Failure Output is activated due to the following failure conditions:

High-Voltage Wake Input

- After four consecutive Watchdog Trigger failures.
- Thermal Shutdown **TSD2**.
- VCC1 short to GND.
- VCC1 overvoltage in case **VCC1_OV_MOD**=11_B.
- after four consecutive VCC1 undervoltage detection.

In order to deactivate the Fail Output, the failure conditions (e.g. TSD2) must not be present anymore and the bit **FAILURE** needs to be cleared via SPI command.

In case of Watchdog fail, the deactivation of the Fail Output is only allowed after a successful WD trigger, i.e. the **FAILURE** bit must be cleared.

*Note: The internally stored default value used for the wake-enabled configuration is 'low'. A level change will be signaled in the corresponding bits in **WK_STAT** in case the externally connected signal proceeds a rising or falling edge transition if the WK-enable is configured to high.*

High-Voltage Wake Input

10.3 Electrical Characteristics

Table 26 Electrical Characteristics

$V_{SINT} = 5.5\text{ V to }28\text{ V}$; $T_j = -40^\circ\text{C to }+150^\circ\text{C}$; all voltages with respect to ground, positive current flowing into pin (unless otherwise specified)

Parameter	Symbol	Values			Unit	Note or Test Condition	Number
		Min.	Typ.	Max.			
WK1, WK2 ,WK3, WK4 Input Pin Characteristics							
Wake-up/monitoring threshold voltage falling	$V_{WKx_th,f}$	2.5	3	3.5	V	without external serial resistor R_S	P_10.3.1
Wake-up/monitoring threshold voltage rising	$V_{WKx_th,r}$	3	3.5	4	V	without external serial resistor R_S	P_10.3.2
Threshold hysteresis	$V_{WKx_th,hys}$	0.4	0.6	0.85	V	without external serial resistor R_S	P_10.3.3
WK pin Pull-up Current	I_{PU_WKx}	-20	-10	-3	μA	$V_{WKx} = 4\text{ V}$	P_10.3.4
WK pin Pull-down Current	I_{PD_WKx}	3	10	20	μA	$V_{WKx} = 2.5\text{ V}$	P_10.3.5
Input leakage current	$I_{LK,lx}$	-2		2	μA	$0\text{ V} < V_{WKx} < 40\text{ V}$; Pull-up / Pull-down disabled	P_10.3.6

WK4 as SYNC input pin

LOW input voltage threshold	$WK4_{SYNC_th,L}$	$0.3 \times V_{CC1}$	-	-	V		P_10.3.11
HIGH input voltage threshold	$WK4_{SYNC_th,H}$	-	-	$0.7 \times V_{CC1}$	V		P_10.3.12
Pull-down resistance on WK/SYNC	R_{SYNC}	20	40	80	k Ω	$V_{SYNC} = 1\text{ V}$	P_10.3.13

WK2/FO as Fail Safe Output

FO low-side output voltage (active)	$V_{FO,L1}$	-	0.6	1	V	WK2 configured as Fail-Safe Output; $I_{FO} = 4.0\text{ mA}$	P_10.3.14
FO input leakage current (all inactive)	$I_{FO,LK}$	-	-	2	μA	$V_{FO} = 28\text{ V}$	P_10.3.15

Timing

Wake-up filter time 1	t_{FWK1}	12	16	22	μs	¹⁾	P_10.3.16
Wake-up filter time 2	t_{FWK2}	50	64	80	μs	¹⁾	P_10.3.17

1) Not subject to production test, tolerance defined by internal oscillator tolerance.

Interrupt Function

11 Interrupt Function

11.1 Block and Functional Description

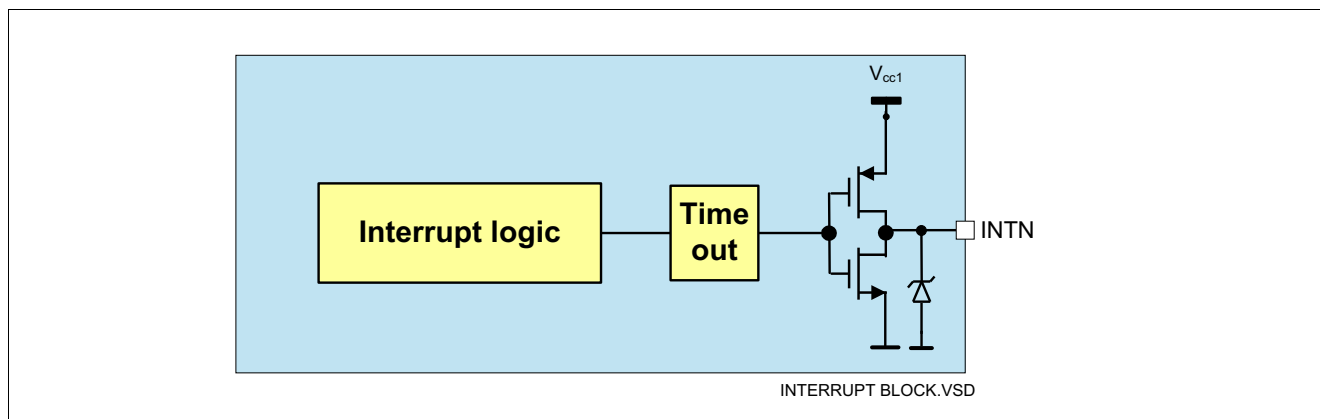

Figure 44 Interrupt Block Diagram

The interrupt is used to signalize special events in real time to the microcontroller. The interrupt block is designed as a push/pull output stage as shown in [Figure 44](#). An interrupt is triggered and the INTN pin is pulled low (active low) for t_{INTN} in Normal Mode and Stop Mode and it is released again once t_{INTN} is expired. The minimum high-time of INTN between two consecutive interrupts is t_{INTND} . An interrupt does not cause a device mode change.

Two different interrupt generation methods are implemented:

- Interrupt Mask: One dedicated register (INT_MASK) is intended to enable or disable set of interrupt sources. The interrupt sources follow the SPI Status Information Field.
In details:
 - SUPPLY_STAT: “OR” of all bits on SUP_STAT register except POR, VCC1_UV, VCC1_SC, VCC1_OV
 - TEMP_STAT: “OR” of all bits on THERM_STAT register except TSD2
 - BUS_STAT: “OR” of all bits on BUS_STAT register
 - HS_STAT: “OR” of all bits on HS_OL_OC_OT_STAT register
 - BD_STAT: “OR” of all bits on DSOV register
 - SPI_CRC_FAIL: or between SPI_FAIL and CRC_FAIL bits on DEV_STAT register.
- Wake-up events: all wake-up events stored in the wake status SPI register WK_STAT only in case the corresponding input was configured as wake-up source.
The wake-up sources are:
 - via CAN (wake-up pattern or wake-up frame)
 - via LIN
 - via WK pins
 - via TIMERx (cyclic wake)
 - via LSx_DSOV_BRK if any of the brake-feature is enabled

The methods are both available at the same time.

Note: The errors which will cause Restart or Fail-Safe Mode (VCC1_UV, VCC1_SC, VCC1_OV, TSD2) are the exceptions of an INTN generation. Also the bit POR will not generate interrupts. If the above

Interrupt Function

mentioned bits are not cleared after the device is back in Normal Mode or Stop Mode, the INTN is periodically generated (Register based cyclic interrupt generation).

Note: Periodical interrupts are only generated by CRC fail and SPI fail from DEV_STAT register.

Note: During Restart Mode the SPI is blocked and the microcontroller is in reset. Therefore the INTN will not be in Restart Mode, which is the same behavior in Fail-Safe Mode or Sleep Mode.

In addition to this behavior, INTN will be triggered when Stop Mode is entered and not all wake source bits were cleared in the WK_STAT register and also the LSx_DSOV_BRK bits in the DSOV register..

The SPI status registers are updated at every falling edge of the INTN pulse. All interrupt events are stored in the respective register until the register is cleared via SPI command. A second SPI read after reading out the respective status register is optional but recommended to verify that the interrupt event is not present anymore. The interrupt behavior is shown in **Figure 45**.

The INTN pin is also used during Init Mode to select the Software Development Mode entry. See **Chapter 5.2** for further information.

In case of pending INTN event (SPI Status registers are not cleared after INTN event), additional periodical INTN events are generated as shown in **Figure 46**.

The periodical INTN events generation can be disabled via SPI command using **INTN_CYC_EN** bit.

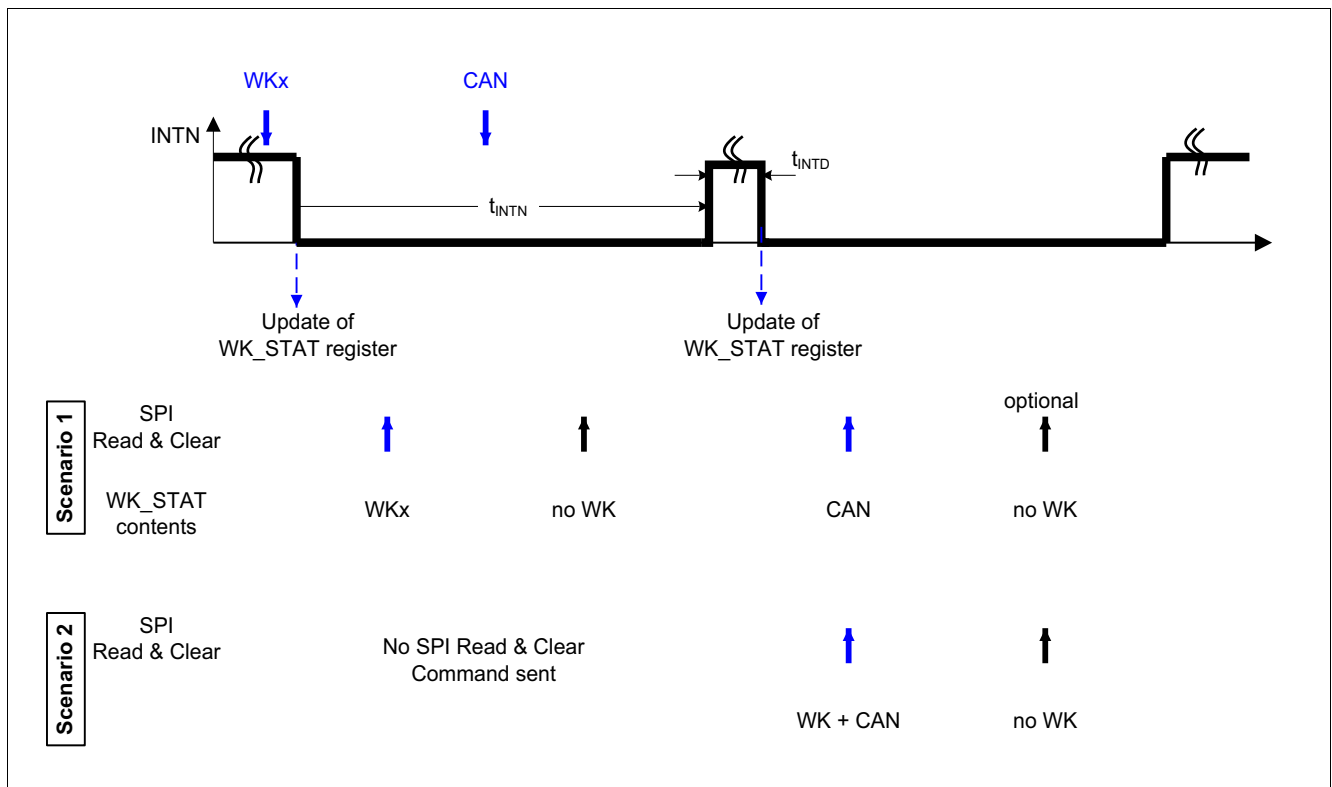

Figure 45 Interrupt Signalization Behavior

Note: For two or more interrupt events at the same time, when INTN pin is low the same time, it will not start multiple toggling.

Interrupt Function

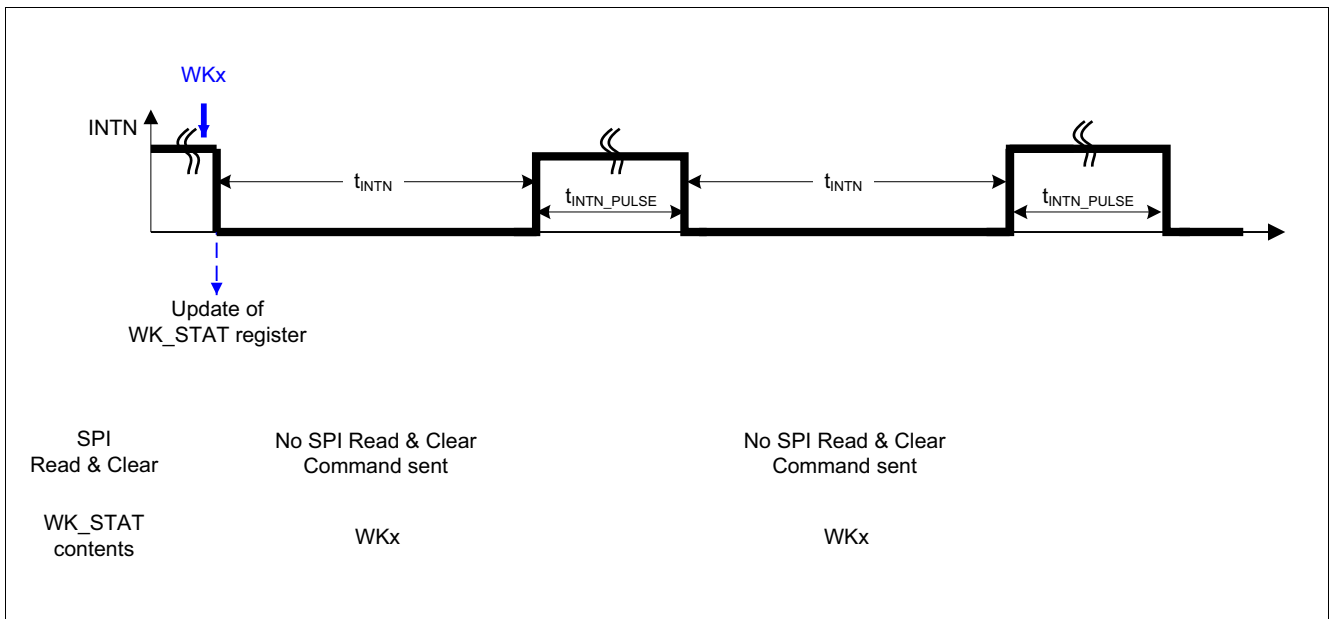

Figure 46 Interrupt Signalization Behavior in case of pending INTN events

Interrupt Function

11.2 Electrical Characteristics

Table 27 Electrical Characteristics

$V_{SINT} = 5.5\text{ V to }28\text{ V}$; $T_j = -40^\circ\text{C to }+150^\circ\text{C}$; Normal Mode; all voltages with respect to ground; positive current defined flowing into pin; unless otherwise specified.

Parameter	Symbol	Values			Unit	Note or Test Condition	Number
		Min.	Typ.	Max.			
Interrupt Output; Pin INTN							
INTN High Output Voltage	$V_{INTN,H}$	$0.8 \times V_{CC1}$	–	–	V	¹⁾ $I_{INTN} = -2\text{ mA}$; INTN = off	P_11.2.1
INTN Low Output Voltage	$V_{INTN,L}$	–	–	$0.2 \times V_{CC1}$	V	¹⁾ $I_{INTN} = 2\text{ mA}$; INTN = on	P_11.2.2
INTN Pulse Width	t_{INTN}	80	100	120	μs	²⁾	P_11.2.3
INTN Pulse Minimum Delay Time	t_{INTND}	80	100	120	μs	²⁾ between consecutive pulses	P_11.2.4
Pulse in case of pending INTN	t_{INTN_PULSE}	4	5	6	ms	²⁾ between consecutive pulses	P_11.2.5
SDM Select; Pin INTN							
Config Pull-up Resistance	R_{SDM}	30	60	100	k Ω	$V_{INTN} = 5\text{ V}$	P_11.2.6
Config Select Filter Time	t_{SDM_F}	50	64	80	μs	²⁾	P_11.2.7

1) Output Voltage Value also determines device configuration during Init Mode.

2) Not subject to production test, tolerance defined by internal oscillator tolerance.

12 Gate Drivers

The TLE9562-3QX integrates eight floating gate drivers capable of controlling a wide range of N-channel MOSFETs. They are configured as four high-sides and four low-sides, building four half-bridges.

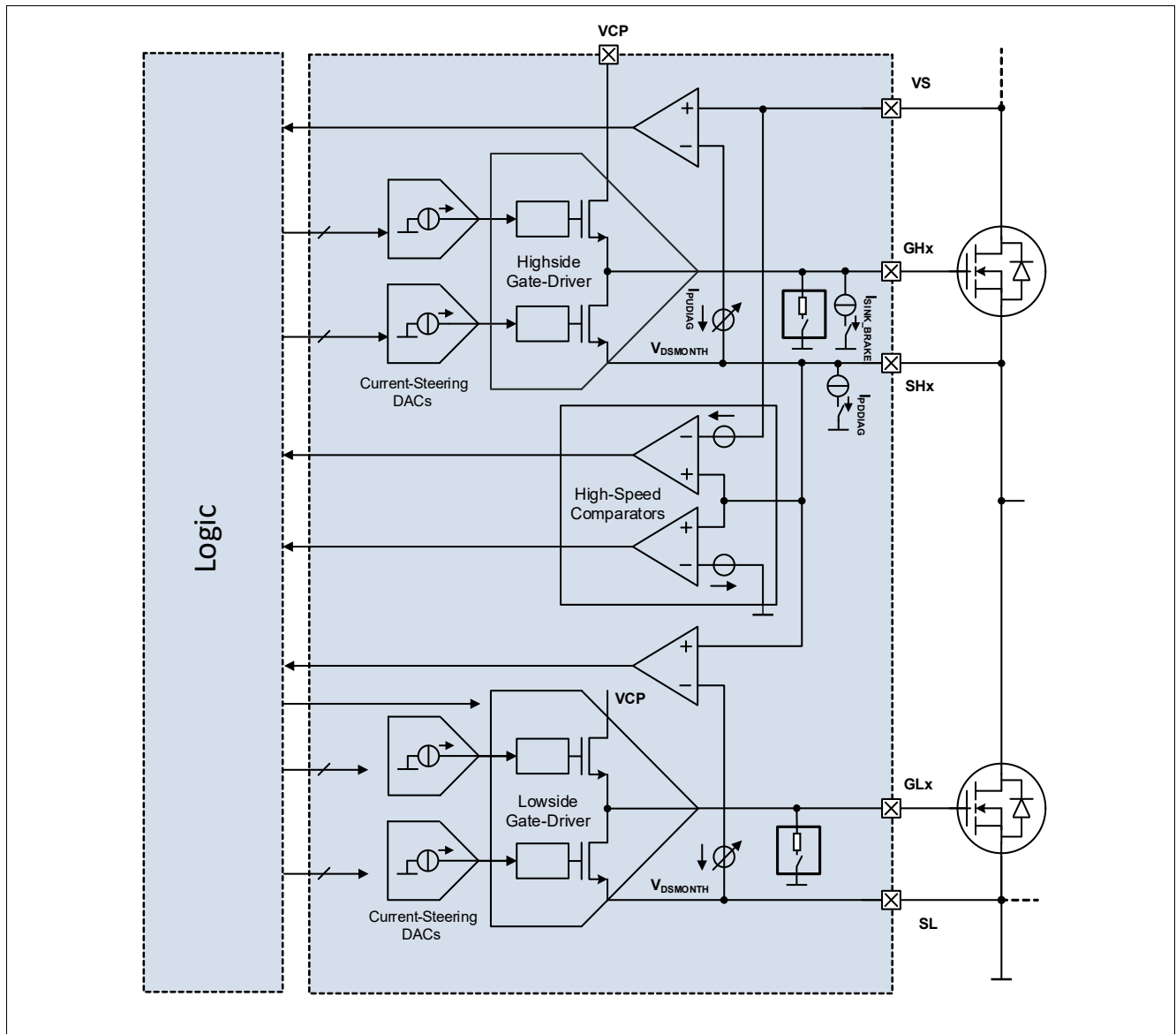

Figure 47 Half-bridge gate driver - Block diagram

This section describes the MOSFET control in static activation and during PWM operation.

Note: PWMx mentioned in this chapter refer to the PWMx pins and signal used by the bridge driver to control the external MOSFETs.

Note: In this chapter PWMx **do not refer** to the internal PWM generators used to control the internal high-side switches HSx.

12.1 MOSFET control

Depending on the configuration bits HBxMODE[1:0] (refer to **HBMODE**), **CPEN**, each high-side and low-side MOSFETs can be:

Gate Drivers

- Kept off with the passive discharge.
- Kept off actively.
- Activated (statically, no PWM, HBx_PWM_EN = 0).
- Activated in PWM mode (HBx_PWM_EN = 1).

Refer to **Table 28** for details.

Table 28 Half-bridge mode selection

CPEN	HBxMODE[1:0] ¹⁾	Configuration of HSx/LSx ¹⁾
CPEN = 0	Don't care	All MOSFETs are kept off by the passive discharge
CPEN = 1	00 _B	HBx MOSFETs are kept off by the passive discharge
CPEN = 1	01 _B	LSx MOSFET is ON, HSx MOSFET is actively kept OFF
CPEN = 1	10 _B	HSx MOSFET is ON, LSx MOSFET is actively kept OFF
CPEN = 1	11 _B	LSx and HSx MOSFETs are actively kept OFF with IHOLD

1) x = 1 ... 4

12.2 Static activation

In this section, we consider the static activation of the high-side and low-side MOSFET of the half-bridge x: HBx_PWM_EN= 0 (in **ST_ICHG**) and **CPEN** = 1.

The low-side or high-side MOSFET of HBx is statically activated (no PWM) by setting HBxMODE[1:0] to respectively (0,1) or (1,0).

The configured active cross-current protection and the Drain-Source overvoltage blank times for the Half-Bridge x are noted $t_{HBxCCP\ ACTIVE}$ and $t_{HBxBLANK\ ACTIVE}$.

The charge and discharge currents applied to the static controlled Half-Bridge x are noted ICHGSTx (**ST_ICHG**).

IHARDOFF is the maximum current that the gate drivers can sink (100 mA typ.). This current is used to keep a MOSFET off, when the opposite MOSFET of the same half-bridge is being turned on. This feature reduces the risk of parasitic cross-current conduction.

ICHGSTx is the current sourced, respectively sunk, by the gate driver to turn-on the high-side x or low-side x. ICHGSTx is configured in the control register **ST_ICHG**.

Table 29 Static charge and discharge currents

ICHGSTx[3:0]	Nom. charge current [mA]	Nom. discharge current [mA]	Max. deviation to typ. values
0000 _B	0.5 (I_{CHG0})	0.5 (I_{DCHG0})	+/- 60 %
0001 _B	1.4 (I_{CHG4})	1.4 (I_{DCHG4})	+/- 60 %
0010 _B	3.1 (I_{CHG8})	3.1 (I_{DCHG8})	+/- 55%
0011 _B	5.7 (I_{CHG12})	5.7 (I_{DCHG12})	+/- 40 %
0100 _B	9.2 (I_{CHG16})	9.2 (I_{DCHG16})	+/- 40 %
0101 _B	13.7 (I_{CHG20})	13.5 (I_{DCHG20})	+/- 40 %

Gate Drivers

Table 29 Static charge and discharge currents (cont'd)

ICHGSTx[3:0]	Nom. charge current [mA]	Nom. discharge current [mA]	Max. deviation to typ. values
0110 _B	19.2 (I_{CHG24})	18.8 (I_{DCHG24})	+/- 40 %
0111 _B	25.8 (I_{CHG28})	25.2 (I_{DCHG28})	+/- 30 %
1000 _B	32.8 (I_{CHG32})	32.2 (I_{DCHG32})	+/- 30 %
1001 _B	40.1 (I_{CHG36})	39.4 (I_{DCHG36})	+/- 30 %
1010 _B	47.8 (I_{CHG40})	47.0 (I_{DCHG40})	+/- 30 %
1011 _B	55.9 (I_{CHG44})	55.0 (I_{DCHG44})	+/- 30 %
1100 _B	64.3 (I_{CHG48})	63.2 (I_{DCHG48})	+/- 30 %
1101 _B	73.2 (I_{CHG52})	72.4 (I_{DCHG52})	+/- 30 %
1110 _B	82.7 (I_{CHG56})	82.1 (I_{CHG56})	+/- 30 %
1111 _B	92.7 (I_{CHG60})	92.2 (I_{CHG60})	+/- 30 %

IHOLD is the hold current used to keep the gate of the external MOSFETs in the desired state. This parameter is configurable with the IHOLD control bit in **GENCTRL**.

If the control bit IHOLD = 0:

- A MOSFET is kept ON with the current I_{CHG19} .
- A MOSFET is kept OFF with the current I_{DCHG19} .

If the control bit IHOLD = 1:

- A MOSFET is kept ON with the current I_{CHG25} .
- A MOSFET is kept OFF with the current I_{CHG25} .

12.2.1 Static activation of a high-side MOSFET

Turn-on with cross-current protection

If LSx is ON (HBxMODE[1:0] = 01_B), before the activation of HSx (HBxMODE[1:0] = 10_B) then the high-side MOSFET is turned on after a cross-current protection time (refer to **Figure 48**):

- After the CSN rising edge and for the duration $t_{HBxCCP\ ACTIVE}$:
 - The high-side MOSFET is kept OFF with the current -ICHGSTx.
 - The gate of the low-side MOSFET is discharged with the current -ICHGSTx.
- At the end of $t_{HBxCCP\ ACTIVE}$ and for the duration $t_{HBxBLANK\ ACTIVE} + t_{FVDS}$:
 - The gate of the high-side MOSFET is charged with the current ICHGSTx.
 - Low-side MOSFET is kept OFF with the current -IHARDOFF (hard off phase).
- At the end of t_{FVDS} :
 - The drive current of the high-side MOSFET is reduced to IHOLD.
 - The drive current of the low-side MOSFET is set to -IHOLD.

Gate Drivers

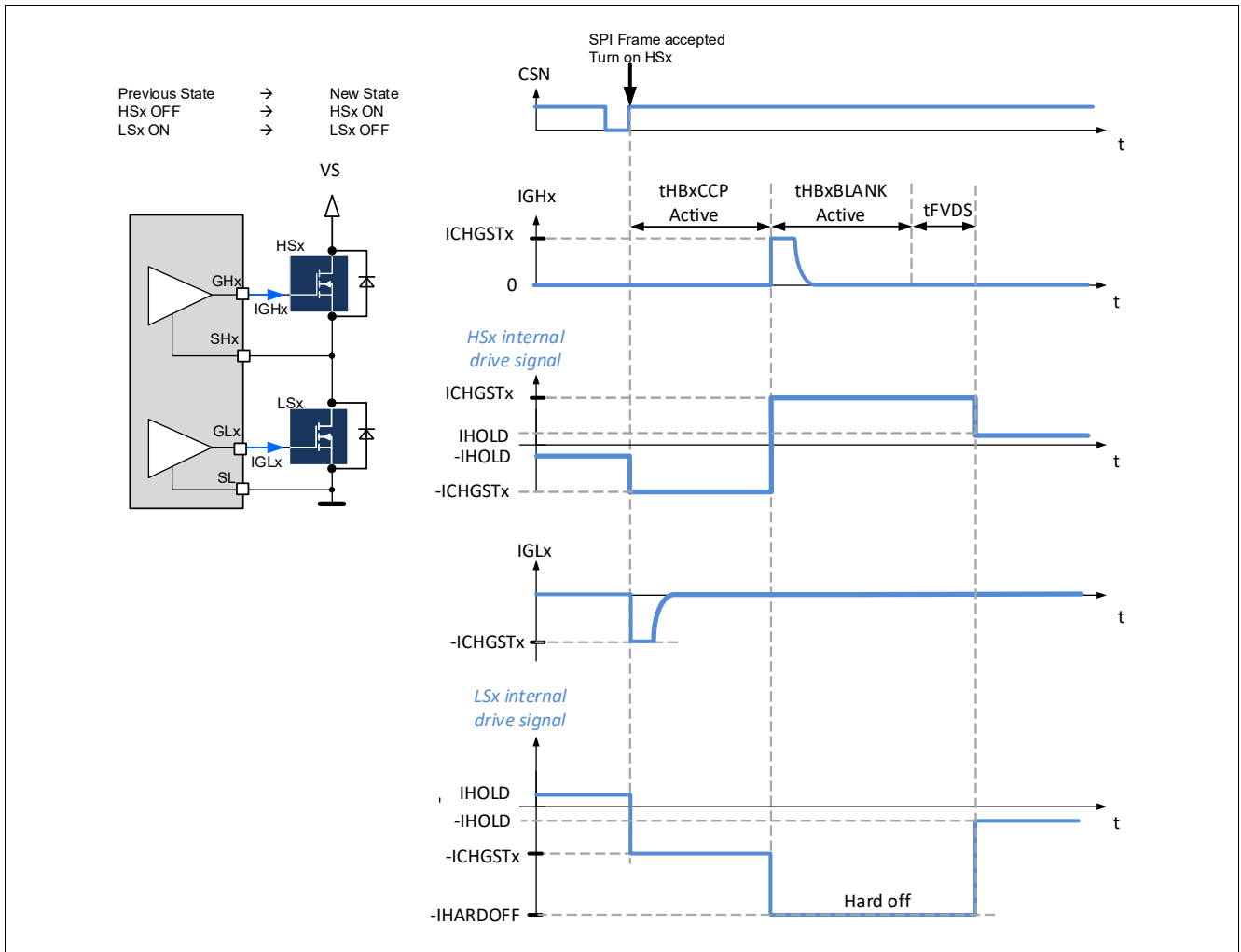

Figure 48 Turn-on of a high-side MOSFET with cross-current protection

Note: The CSN rising edge must be synchronized with the device logic. Therefore SPI commands are executed with a delay of up to 3 μ s after the CSN rising edge.

Gate Drivers

Turn-on without cross-current protection

If LSx is OFF ($HBxMODE[1:0] = 11_B$), before the activation of HSx ($HBxMODE[1:0] = 10_B$), then the high-side MOSFET is turned on without cross-current protection (refer to **Figure 49**):

- right after the CSN rising edge and for a duration $t_{HBxBLANKACTIVE} + t_{FVDS}$:
 - The gate of the high-side MOSFET is charged with the current $ICHGSTx$.
 - The low-side MOSFET is kept OFF with the current $-IHARDOFF$.
- At the end of t_{FVDS} :
 - The drive current of the high-side MOSFET is reduced to $IHOLD$.
 - The drive current of the low-side MOSFET is set to $-IHOLD$.

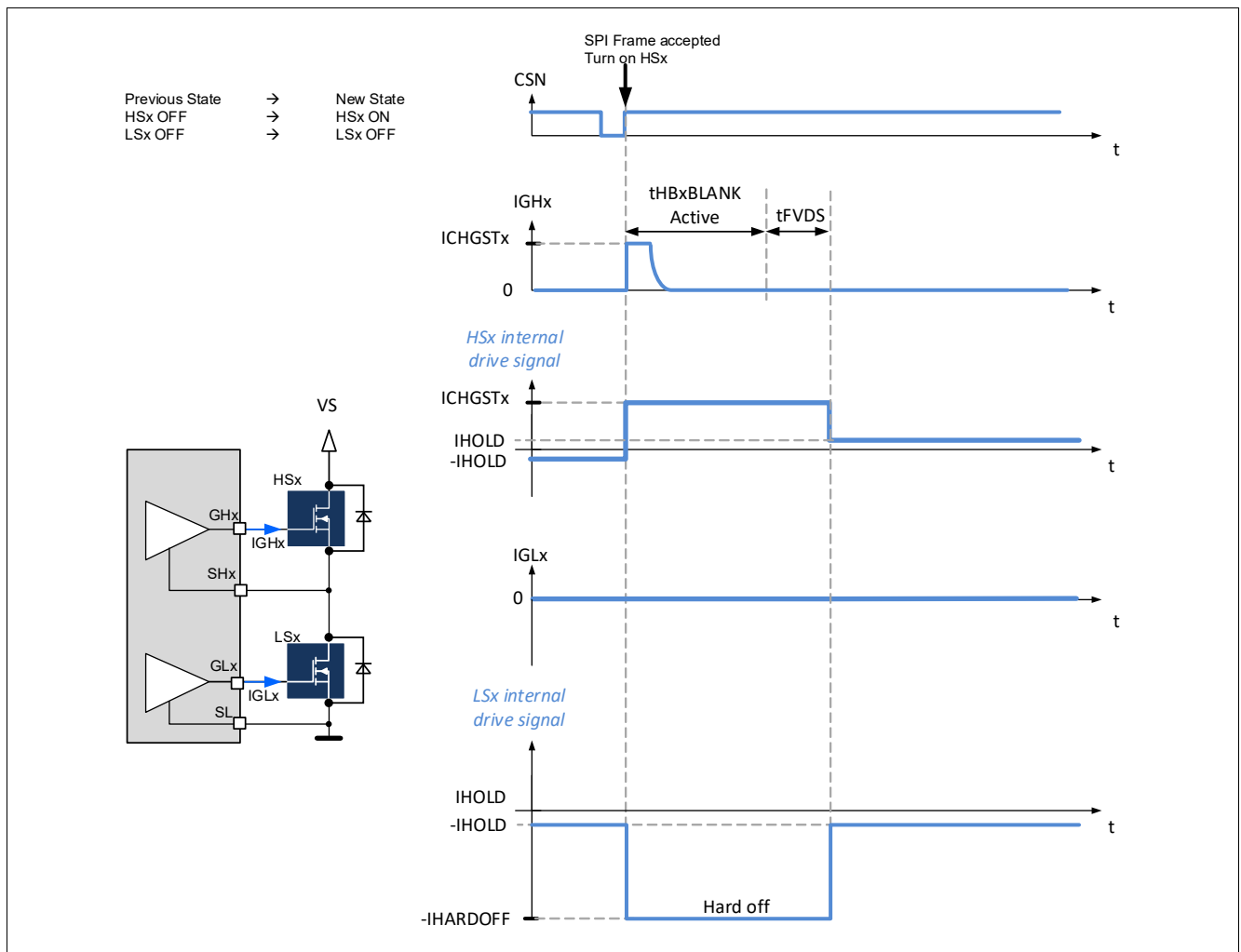

Figure 49 Turn-on of a high-side MOSFET without cross-current protection

Note: The CSN rising edge must be synchronized with the device logic. Therefore SPI commands are executed with a delay of up to 3 μ s after the CSN rising edge.

12.2.2 Static activation of a low-side MOSFET

The description of the static activation of a low-side x differs from the description of [Chapter 12.2.1](#) only by exchanging high-side x and low-side x.

12.2.3 Turn-off of the high-side and low-side MOSFETs of a half-bridge

When the TLE9562-3QX receives a SPI command to turn-off both the high-side and low-side MOSFETs of the half-bridge x ($HBxMODE[1:0] = (0,0)$ or $(1,1)$):

- The gate of HSx and LSx are discharged with the current $-ICHGSTx$ for the duration $t_{HBxCCP ACTIVE}$ ([Figure 50](#)).
- At the end of $t_{HBxCCP ACTIVE}$, the drive current of HSx and LSx are reduced to $-IHOLD$.

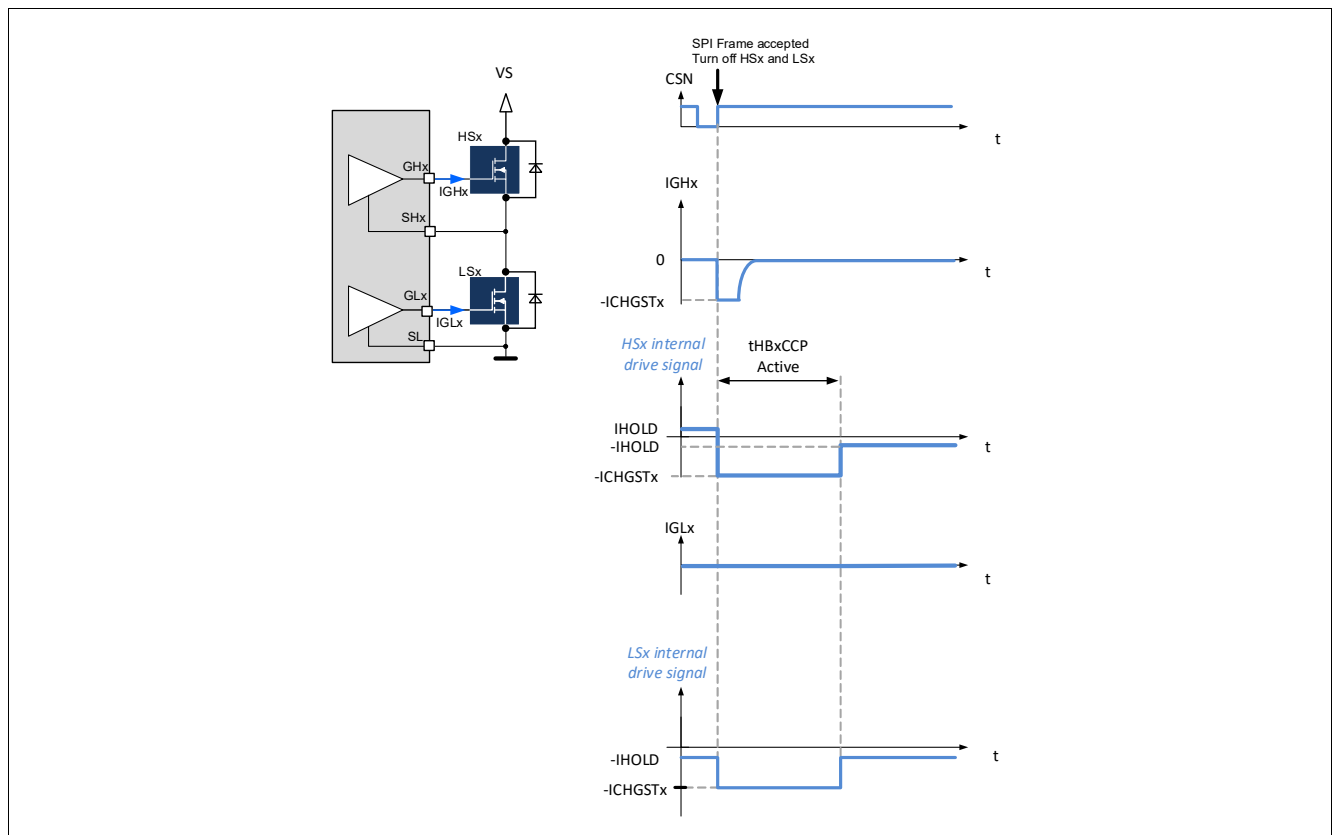

Figure 50 Turn-off of the high-side and low-side MOSFETs of a half-bridge

Note: The CSN rising edge must be synchronized with the device logic. Therefore SPI commands are executed with a delay of up to $3 \mu s$ after the CSN rising edge.

Gate Drivers

12.3 PWM operation

The pins PWMx provide the PWM signal for each PWM channel.

Each half-bridge is activated in PWM mode by setting the corresponding HBx_PWM_EN bit (**HBMODE**).

12.3.1 Determination of the active and freewheeling MOSFET

If **EN_GEN_CHECK** = 1, right before each MOSFET activation, the device detects which MOSFET of the half-bridge is the active MOSFET and which MOSFET is the free-wheeling (FW) MOSFET (**Figure 51**):

- If $V_{SHx} > V_{SHH}$: The high-side MOSFET is the FW MOSFET and the low-side MOSFET is the active MOSFET.
- If $V_{SHx} < V_{SHL}$: Then the low-side MOSFET is the FW MOSFET and the high-side MOSFET is the active MOSFET.
- If $V_{SHL} < V_{SHx} < V_{SHH}$: No clear distinction between the active FW MOSFET and the active MOSFET. The next MOSFET to be turned on is turned on as if it was the active MOSFET.
- No distinction between active MOSFET and FW MOSFET is possible (and the PWM MOSFET is considered as the active MOSFET), if:
 - the ON-time of the external PWM signal is shorter than $t_{HBxCCP\ FW}$
 - the OFF-time of the external PWM signal is shorter than $t_{HBxCCP\ Active}$

Note: The PWM signal is applied to the MOSFET selected by **HBxMODE[1:0]**, independently from the free-wheeling and the active MOSFET.

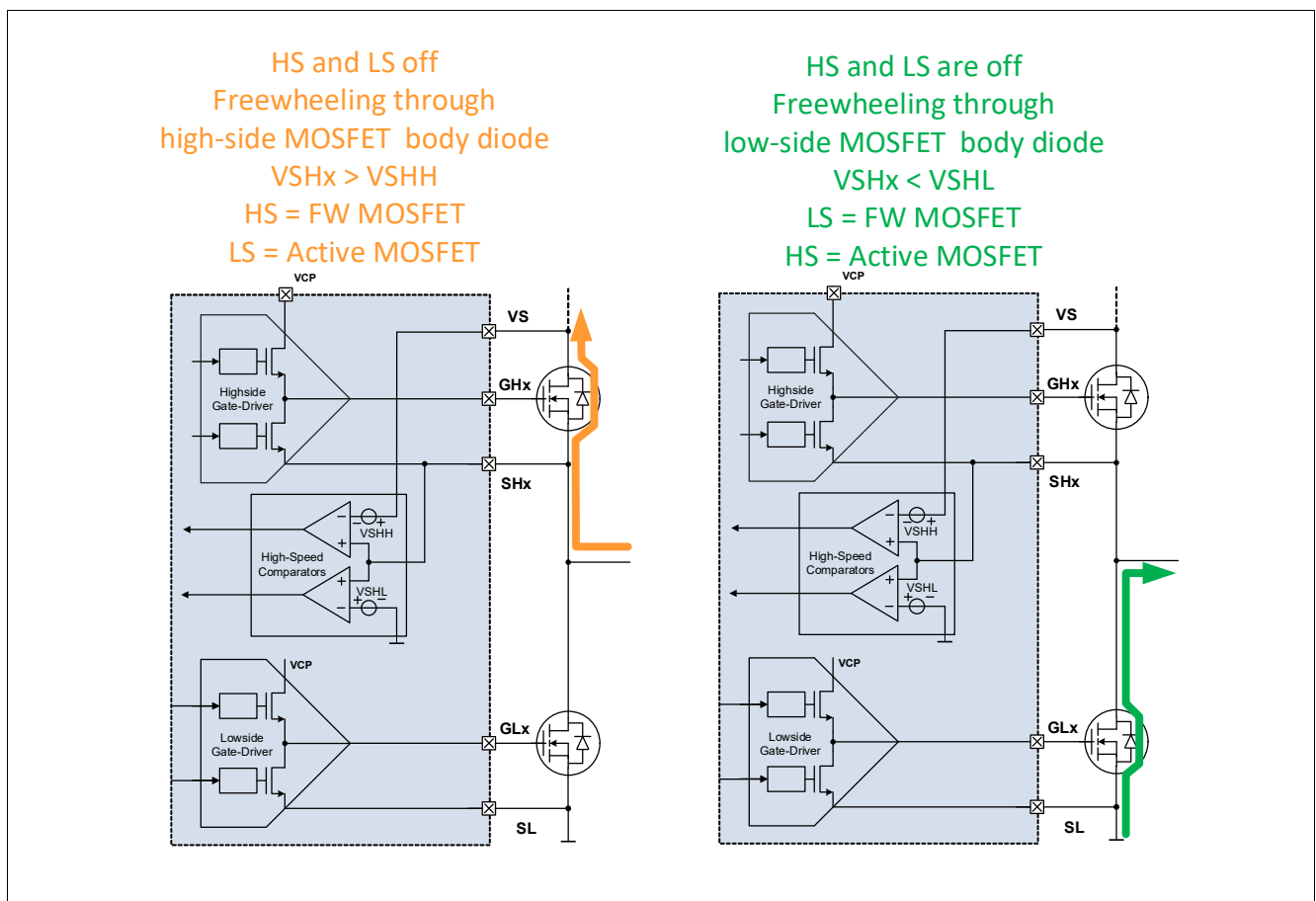

Figure 51 Detection of the active and FW MOSFET (**EN_GEN_CHECK** = 1)- Principle

Gate Drivers

Figure 52 and Figure 53 show examples of free-wheeling and active MOSFET when the motor operates as load.

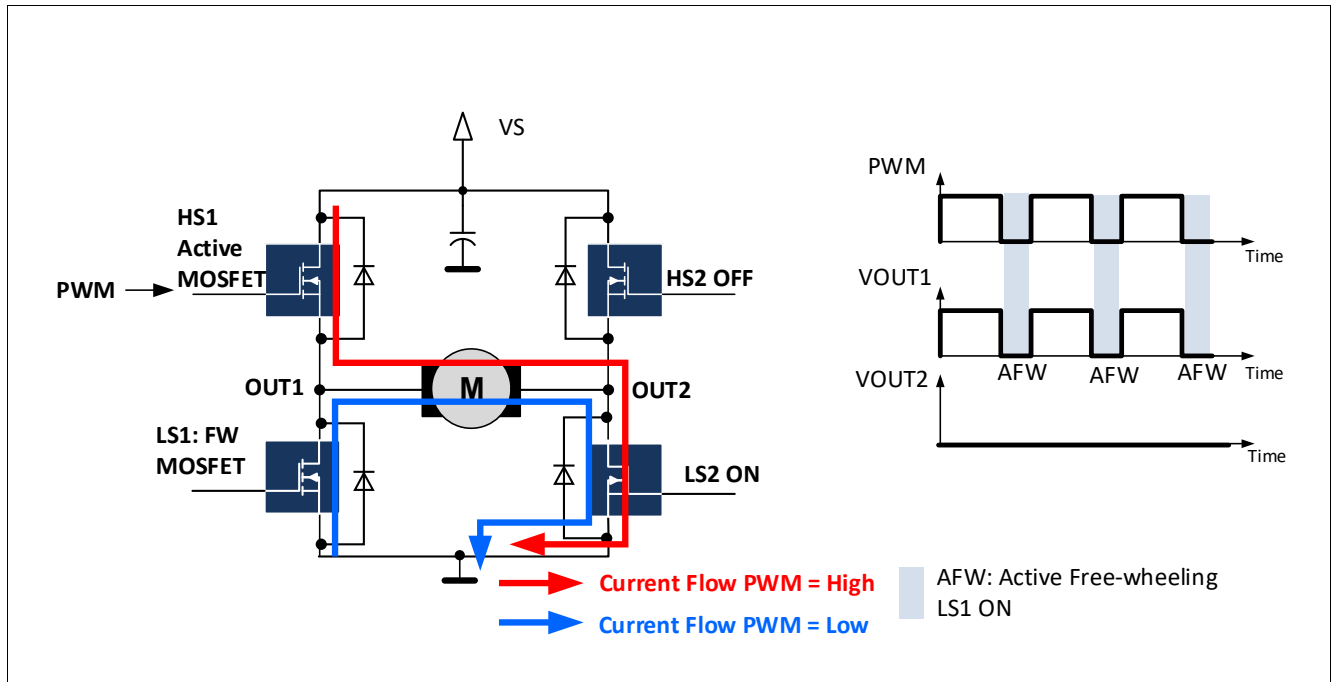

Figure 52 Active freewheeling on HB1: AFW1 = 1, HB1_PWM_EN = 1. PWM applied to HS1 (HB1MODE[1:0] = 10_B). The motor operates as load: HS1 is the active MOSFET, LS1 is the FW MOSFET.

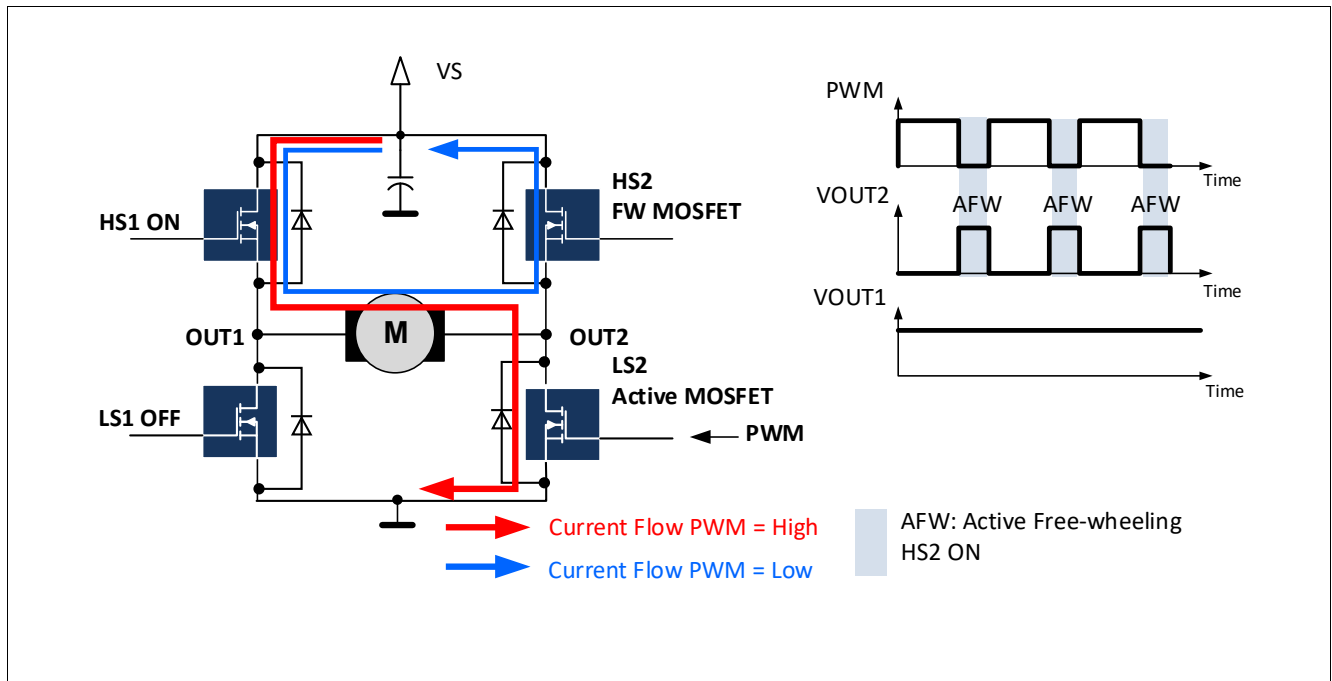

Figure 53 Active freewheeling on HB2: AFW2 = 1, HB1_PWM_EN = 1. PWM applied to LS2 (HB2MODE[1:0] = 01_B). The motor operates as load: LS2 is the active MOSFET, HS2 is the FW MOSFET.

Gate Drivers

Figure 54 and Figure 55 show examples of free-wheeling and active MOSFETs when the motor operates as generator.

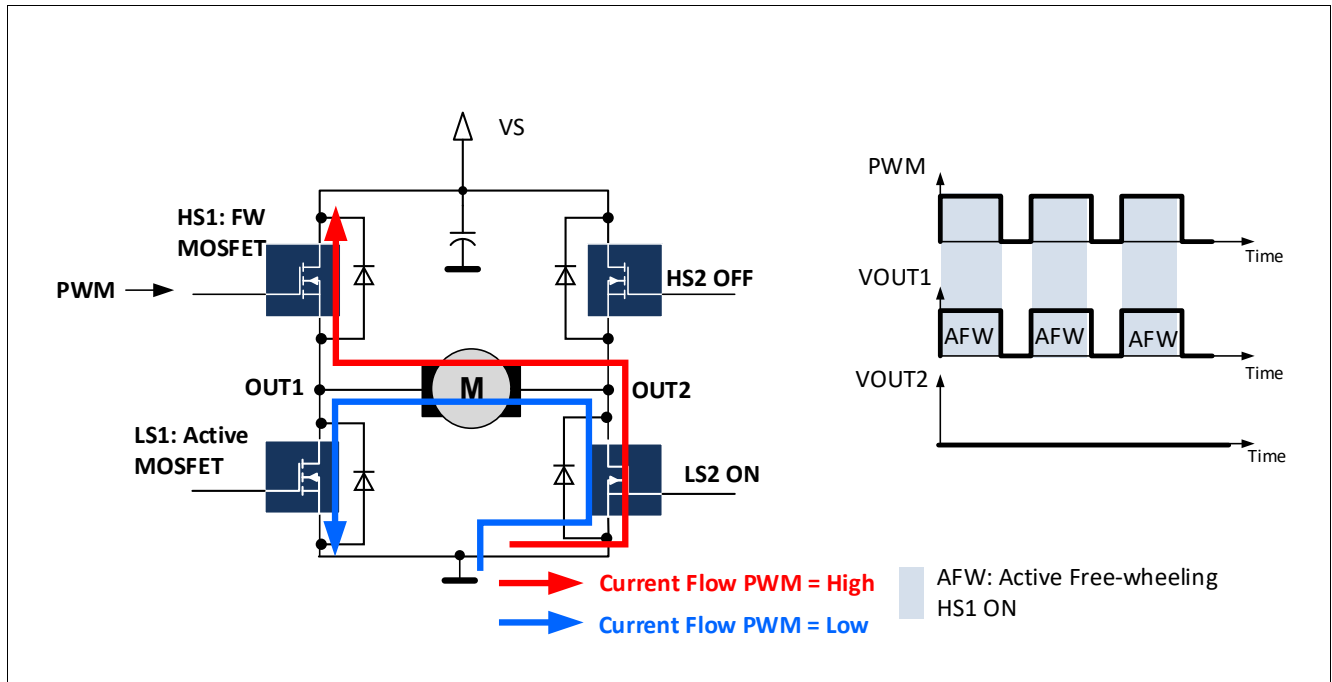

Figure 54 Active freewheeling on HB1: AFW1 = 1, HB1_PWM_EN = 1. PWM applied to HS1 (HB1MODE[1:0] = 10_B), EN_GEN_CHECK = 1. The motor operates as generator: LS1 is the active MOSFET, HS1 is the FW MOSFET.

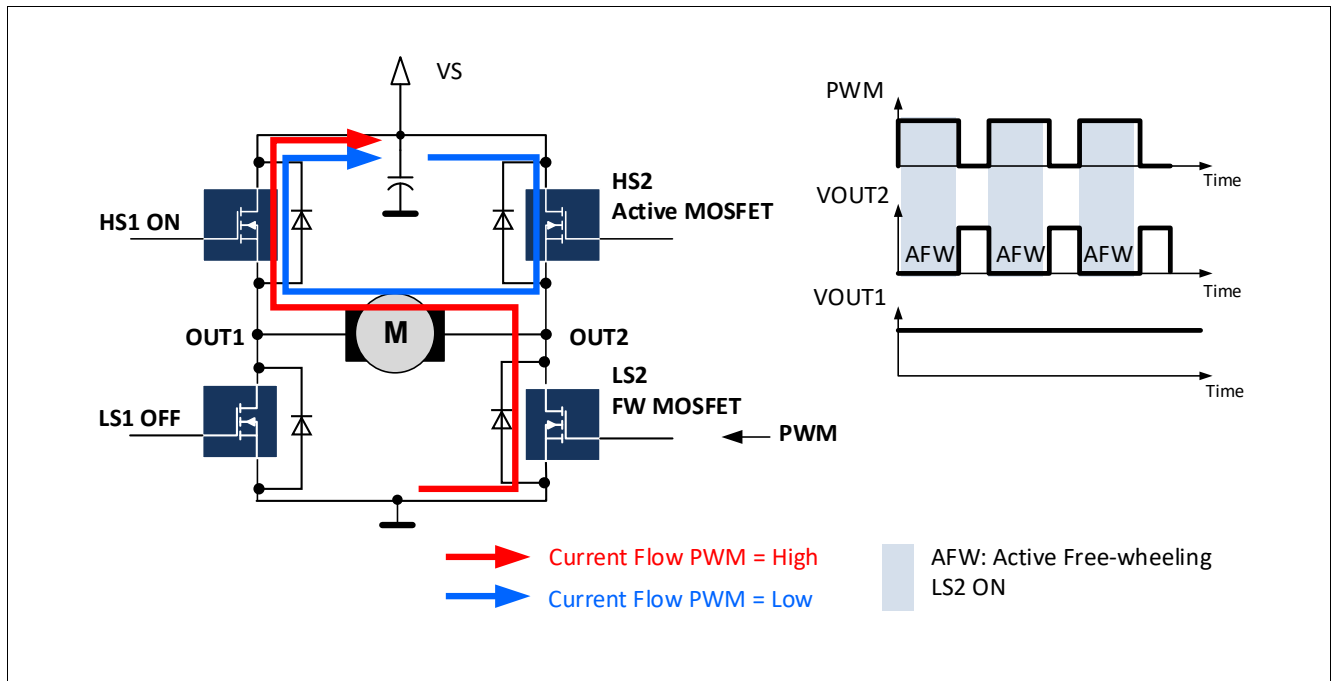

Figure 55 Active freewheeling on HB2: AFW2 = 1, HB1_PWM_EN = 1. PWM applied to LS2 (HB2MODE[1:0] = 01_B), EN_GEN_CHECK = 1. The motor operates as generator: HS2 is the active MOSFET, LS2 is the FW MOSFET.

12.3.2 Configurations in PWM mode

The following sections describe the different control schemes in PWM mode.

Active gate control (AGC)

The control scheme during the pre-charge and pre-discharge phases are configured by the control bits AGC[1:0]:

- Adaptive gate control (AGC[1:0] = (1,0) or (1,1), **GENCTRL**): in this mode a pre-charge current and a pre-discharge current are applied to the gate of the active MOSFET. These currents are used to regulate the turn-on and turn-off delays to the respective target values. Refer to **Chapter 12.3.4**.
- No adaptive gate control (AGC[1:0] = (0,0)): in this mode, the pre-charge and pre-discharge phases (of the active MOSFET) are deactivated. Refer to **Chapter 12.3.5**.
- No adaptive gate control (AGC[1:0] = (0,1)). In this mode:
 - During the pre-charge phase, the gate of the active MOSFET is charged with the configured current IPCHGINIT (**HB_PCHG_INIT**).
 - During the pre-discharge phase, the gate of the active MOSFET is discharged with the configured current IPDCHGINIT (**HB_PCHG_INIT**).

*Note: It is recommended to configure $tPCHGx < tHBxBLANK$ Active and $tPDCHGx < tHBxCCP$ Active (Refer to **TPRECHG** and **CCP_BLK**) independently from the AGC settings.*

Active free-wheeling (AFW)

The active free-wheeling is activated for HBx if the AFWx and HBx_PWM_EN (**HBMODE**) are set to 1 to reduce the power dissipation of the free-wheeling MOSFET. If an active MOSFET is OFF, the opposite MOSFET of the same half-bridge is actively turned on. See examples of high-side and low-side PWM operation in **Figure 52** and **Figure 53**.

If AFWx = 1, a cross-current protection time is applied to HBx (set by **CCP_BLK**) during the PWM operation.

If AFWx = 0, no cross current protection is applied to HBx during the PWM operation.

AFWx can be changed either when HBx is in high impedance or when one of the HBx MOSFETs is on:

- In motor mode :
 - If AFWx is changed from 1 to 0: then the new value of AFWx is read and latched at the end to tCCP FW which follows the PWM rising edge.
 - If AFWx is changed from 0 to 1: then the new value of AFWx is read and latched at the PWM rising edge.
- In generator mode (**EN_GEN_CHECK** = 1): If AFWx is changed from 0 to 1 or from 1 to 0, then the new value of AFWx is read and latched at the end to tCCP active which follows a PWM rising edge.

Gate Drivers

Post-charge

A post-charge is initiated if **POCHGDIS** is set to 0 (**GENCTRL**) to reach the minimum MOSFET $R_{ds(on)}$.

- **POCHGDIS** = 0: The post-charge phase is initiated at the end of the turn-on of the active MOSFET. The charge current is increased by one current step at every bridge driver clock cycle (**BDFREQ**) to **ICHGMAXx**.
- **POCHGDIS** = 1: The post-charge phase is disabled. The charge current is kept to **ICHGx**.

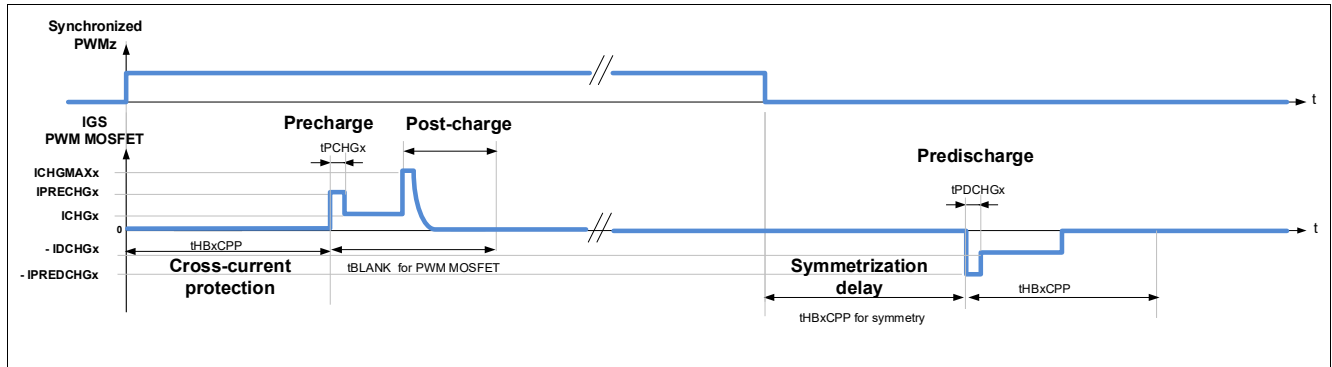

Figure 56 PWM overview - AGC = 10_B or 11_B, POCHGDIS=0, AFWx = 1

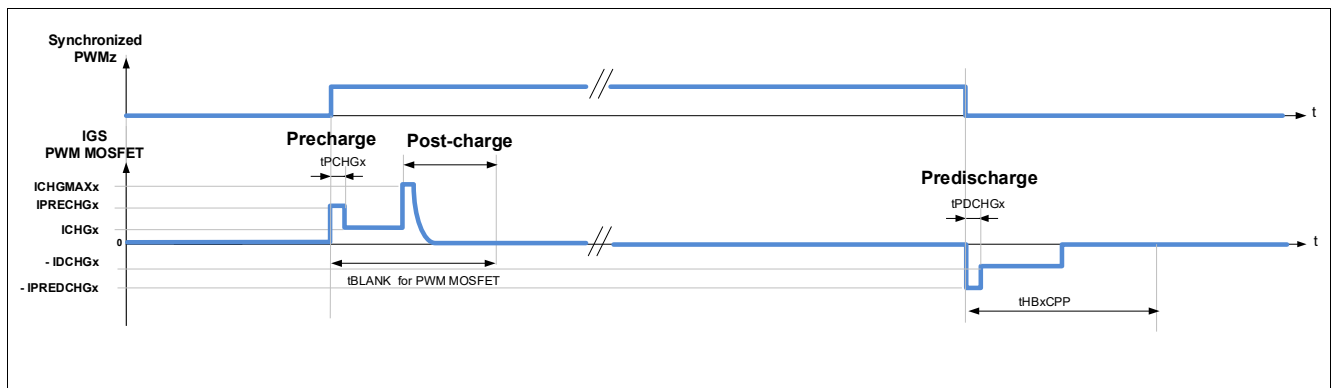

Figure 57 PWM overview - AGC = 10_B or 11_B, POCHGDIS=0, AFWx = 0

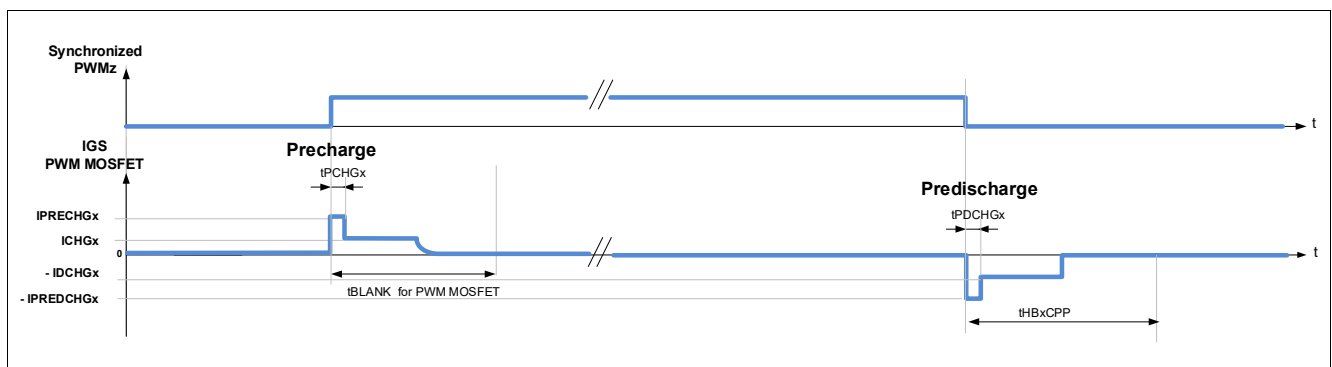

Figure 58 PWM overview - AGC = 10_B or 11_B, POCHGDIS=1, AFWx = 0

12.3.3 PWM mapping

The PWM inputs can be mapped by different half-bridges by setting the configuration bits **PWM12MAP** and **PWM34MAP** in **GENCTRL**.

Gate Drivers

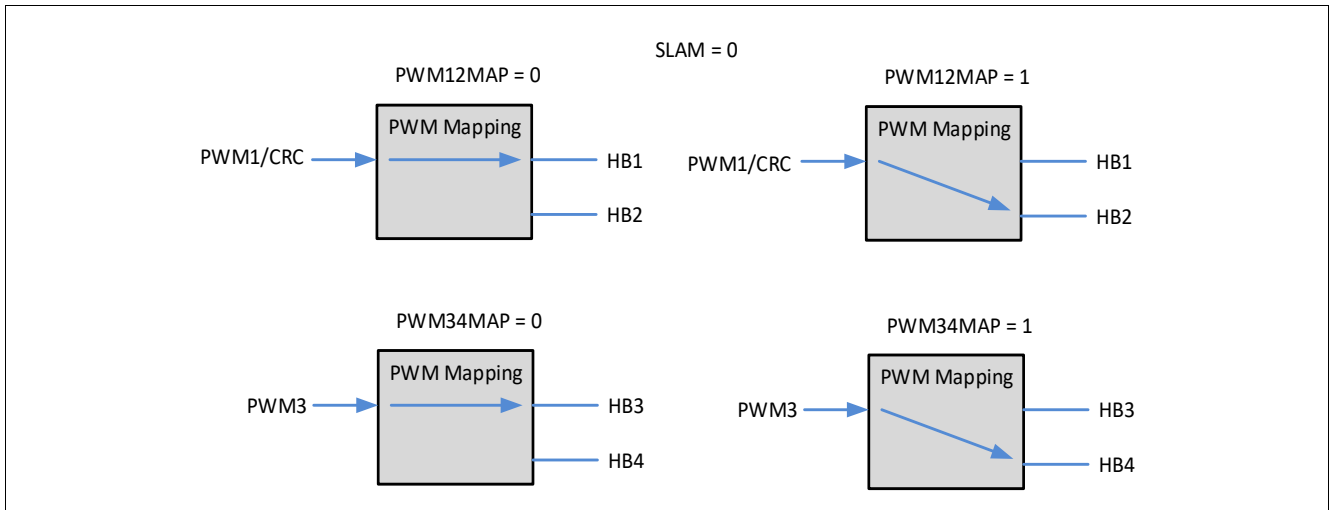

Figure 59 PWM input mapping TLE9562-3QXC

Gate Drivers

12.3.4 PWM operation with adaptive gate control

This section describes the MOSFETs control during high-side or low-side PWM operation when the adaptive gate control is enabled (AGC[1:0] = (1,0) or (1,1), [GENCTRL](#)).

Assumption: A high-side or low-side MOSFET is mapped to the PWM input PWMz.

The TLE9562-3QX adapts the pre-charge current, respectively the pre-discharge current, in order to match the effective turn-on delay (t_{DON}) and turn-off delay (t_{DOFF}) to the configured values.

The configured turn-on and turn-off delays of the respective PWM MOSFETs are set by the registers [TDON_HB_CTRL](#) and [TDOFF_HB_CTRL](#).

The effective turn-on and turn-off delays of the respective PWM MOSFETs are read out from the status registers EFF_TDON_OFFx.

Table 30 Abbreviations for adaptive turn-on and turn-off phases in PWM configuration

Abbreviation	Definition
Suffix x	Related to the half-bridge x.
Suffix z	Related to the PWM input z.
VGS_HSx	Gate-Source voltage of high-side MOSFET x.
IGS_HSx	Gate current of high-side MOSFET x. IGS_HSx is positive when the current flows out of GHx.
VGS_LSx	Gate-Source voltage of low-side MOSFET x.
IGS_LSx	Gate current of low-side MOSFET x. IGS_LSx is positive when the current flows out of GLx.
tPWM_SYNCH	Synchronization delay between external and internal PWM signal.
tHBxCCP ACTIVE	Active cross-current protection time of HBx. See control register CCP_BLK .
tHBxBLANK ACTIVE	Active Drain-source overvoltage blank time of HBx. See control register and CCP_BLK .
tHBxCCP FW	Freewheeling cross-current protection time of HBx. See control register CCP_BLK .
tHBxBLANK FW	Freewheeling drain-source overvoltage blank time of HBx. See control register and CCP_BLK .
PWMz	External PWM signal applied to the input pin PWMz.
ICHGMAXx	Maximum drive current of the half-bridge x during the pre-charge and pre-discharge phases. See control register HB_ICHG_MAX . IPRECHGx and IPREDCHGx are limited to ICHGMAXx.
IPRECHGx	Pre-charge current sourced by the gate driver to the active MOSFET of the half-bridge x during tPCHGx (TPRECHG). Internal and self-adaptive parameter (if AGC[1:0] = (1,0) or (1,1), GENCTRL). IPRECHGx is clamped between I_{CHG0} (0.5 mA typ.) and ICHGMAXx.
IPCHGINITx	Initial value of IPRECHGx. Refer to HB_PCHG_INIT .
IPREDCHGx	Pre-discharge-current sunk by the gate driver mapped to the half-bridge x during tPDCHGx. Internal and self-adaptive parameter (if AGC[1:0] = (1,0) or (1,1), GENCTRL). IPREDCHGx is clamped between I_{DCHG0} (0.5 mA typ.) and ICHGMAXx.
IPDCHGINITx	Initial value of IPREDCHGx. Refer to HB_PCHG_INIT .

Gate Drivers

Table 30 Abbreviations for adaptive turn-on and turn-off phases in PWM configuration (cont'd)

Abbreviation	Definition
ICHGx	Current sourced by the gate driver to the active MOSFET of the half-bridge x during the charge phase. See control register HB_ICHG .
IDCHGx	Current sunk by the gate driver to turn-off the active MOSFET of the half-bridge x during the discharge phase. See control register HB_ICHG .
ICHGFWx	Current sourced or sunk by the gate driver to turn on / turn off the freewheeling MOSFET of the half-bridge x. See control register HB_ICHG .
tPCHGx	Duration of the pre-charge phase of half-bridge x. tPCHGx is configurable by SPI. See control register TPRECHG .
tPDCHGx	Duration of the pre-discharge phase of half-bridge x. tPDCHGx is configurable by SPI. See control register TPRECHG .
tDONx	Turn-on delay of the active MOSFET of HBx.
tDOFFx	Turn-off delay of the active MOSFET of HBx.
IHOLD	Hold current sourced or sunk by the gate driver to keep the MOSFET in the desired state. See IHOLD control bit in GENCTRL .
IHARDOFF	IHARDOFF is the maximum current that the gate drivers can sink. It corresponds to the discharge current when IDCHGx[5:0] = 63 _D (100 mA typ.).
TFVDS	Drain-Source overvoltage filter time. See LS_VDS .

Gate Drivers

12.3.4.1 High-side PWM with adaptive gate control, motor operating as load

The following section describes the MOSFET control when the PWM signal is applied to the high-side MOSFET of one half-bridge while the motor operates as a load.

Assumption: the PWM input z is mapped to the high-side MOSFET of the half-bridge x.

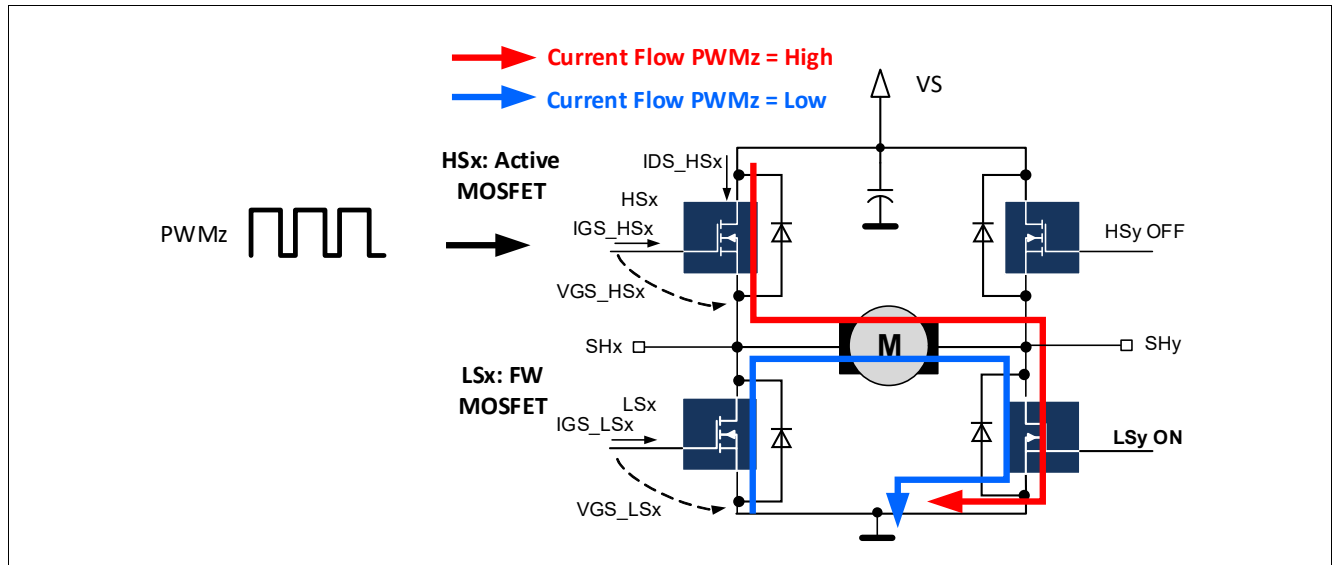

Figure 60 PWM input z is mapped to high-side x, the motor operating as load

12.3.4.1.1 High-side PWM with adaptive gate control and active free-wheeling

This section describes the MOSFETs control scheme applied to HBx with active free-wheeling (AFW_x = 1).

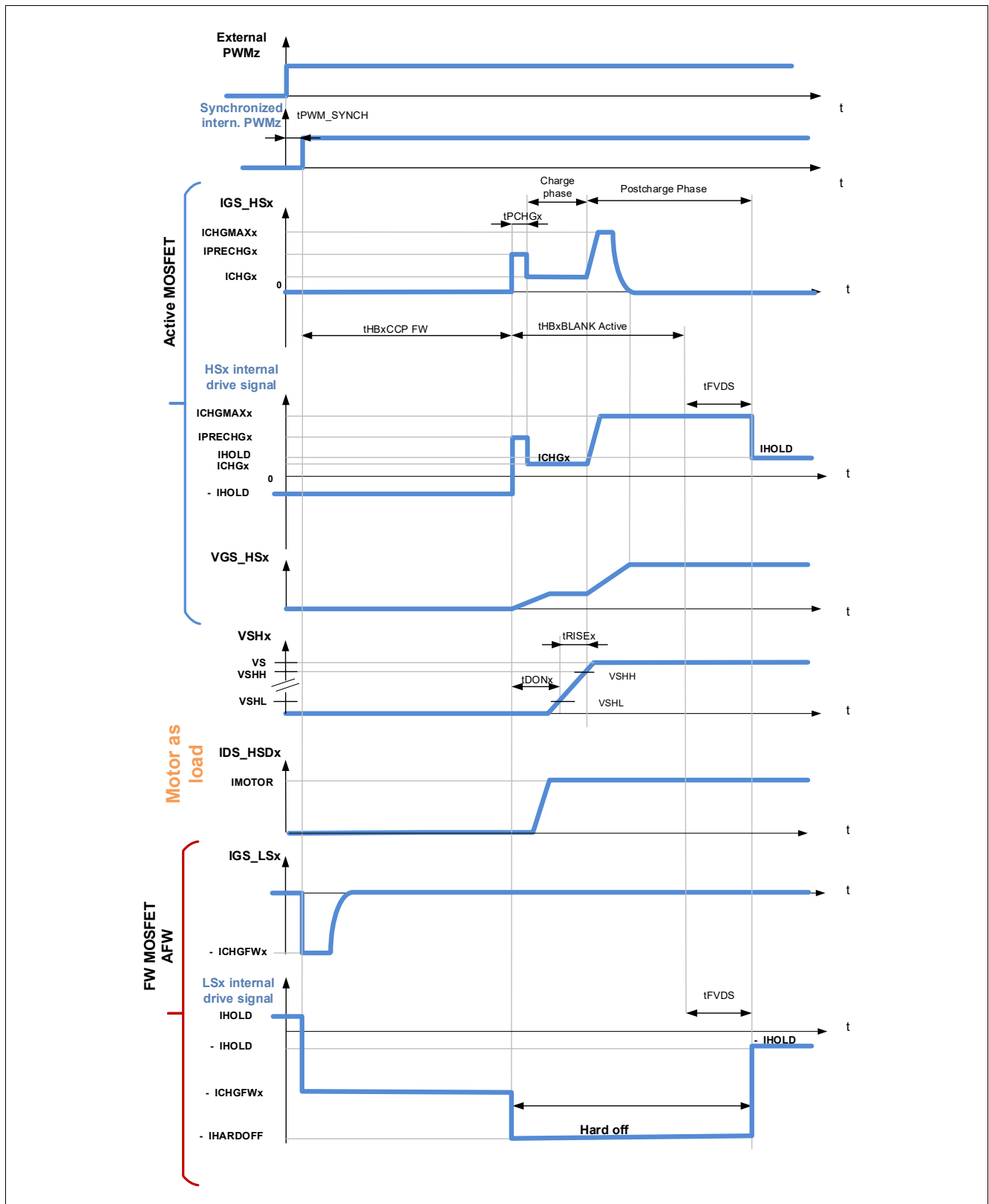

Figure 61 Adaptive turn-on with high-side PWM, AGC[1:0] = (1,0) or (1,1), AFWx=1, POCHGDIS=0, motor operating as load

Adaptive turn-on during high-side PWM

The turn-on of the high-side MOSFET is done in four phases (Refer to Figure 61):

Gate Drivers

1. **Cross-current protection phase:** The cross-current protection tHBxCCP FW starts at the rising edge of PWMz. During tHBxCCP FW, the low-side MOSFET x is turned off with the discharge current - ICHGFWx, while the high-side MOSFET x is kept off.
2. **Pre-charge:** ¹⁾Once tHBxCCP FW has elapsed, the gate of the high-side MOSFET x is pre-charged with the current IPRECHGx for a duration tPCHGx. IPRECHGx²⁾ is an internal parameter, which is self-adaptive (see next phase).
3. **Charge:** After tPCHGx, the charge current is decreased from IPRECHGx down to ICHGx. The effective tDONx³⁾ is measured and compared to the configured tDONx for the automatic adaptation of IPRECHGx (see **Adaptive control of pre-charge current**). The charge phase ends up when V_{SHx} reaches V_{SHH} (typically $V_S - 2.25\text{ V}$)
4. **Post-charge:** After the charge phase, the control signal for the charge current of HSx is increased by one current step at every bridge driver clock cycle (**BDFREQ**) to ICHGMAXx until the end of tFVDS.

Adaptive control of pre-charge current

Refer to **Chapter 12.3.6** for information on the pre-discharge currents.

The pre-charge current IPRECHGx is a self-adaptive parameter if AGC[1:0] = (1,0) or (1,1) (see **GENCTRL**). It is applied during tPCHGx (see **TPRECHG**). The TLE9562-3QX adapts the IPRECHGx to match the effective tDONx to the configured value.

IPRECHGx is clamped between I_{CHG0} (0.5 mA typ.) and ICHGMAXx (**HB_ICHG_MAX**).

IPRECHGx is initialized to $\text{Min}(\text{IPCHGINITx}, \text{ICHGMAXx})$ when the TLE9562-3QX receives an SPI command setting HBx_PWM_EN to 1 (see **HBMODE**). IPCHGINITx is set by the register **HB_PCHG_INIT**.

The following adaptive schemes can be selected.

AGCFILT = 0: No filter is applied:

- If the effective tDONx is longer than the configured tDONx, then IPRECHGx is increased during the next pre-charge phase.
- If the effective tDONx is shorter than the configured tDONx, then IPRECHGx is decreased during the next pre-charge phase.
- The pre-charge current is increased or decreased by one, respectively by two current steps (**Chapter 12.3.6**) if the control bit IPCHGADT in the control register **GENCTRL** is set to 0 respectively 1.

AGCFILT = 1: A filter is applied:

- If the effective tDONx **of the last two PWM cycles** are longer than the configured tDONx, then IPRECHGx is increased during the next pre-charge phase.
- If the effective tDONx **of the last two PWM cycles** are shorter than the configured tDONx, then IPRECHGx is decreased during the next pre-charge phase.
- The pre-charge current is increased or decreased by one, respectively by two current steps (**Chapter 12.3.6**) if the control bit IPCHGADT in the control register **GENCTRL** is set to 0 respectively 1.
- If none of the two cases are applicable, then IPRECHGx is unchanged during the next pre-charge phase.

1) For a correct operation, it is recommended to configure tPCHGx < tHBxBLANK Active.

2) IPRECHGx is clamped between ICHGMAXx and I_{CHG0} .

3) The effective tDON can be read out. Refer to **EFF_TDON_OFF1**, **EFF_TDON_OFF2**, **EFF_TDON_OFF3**, **EFF_TDON_OFF4**.

Gate Drivers

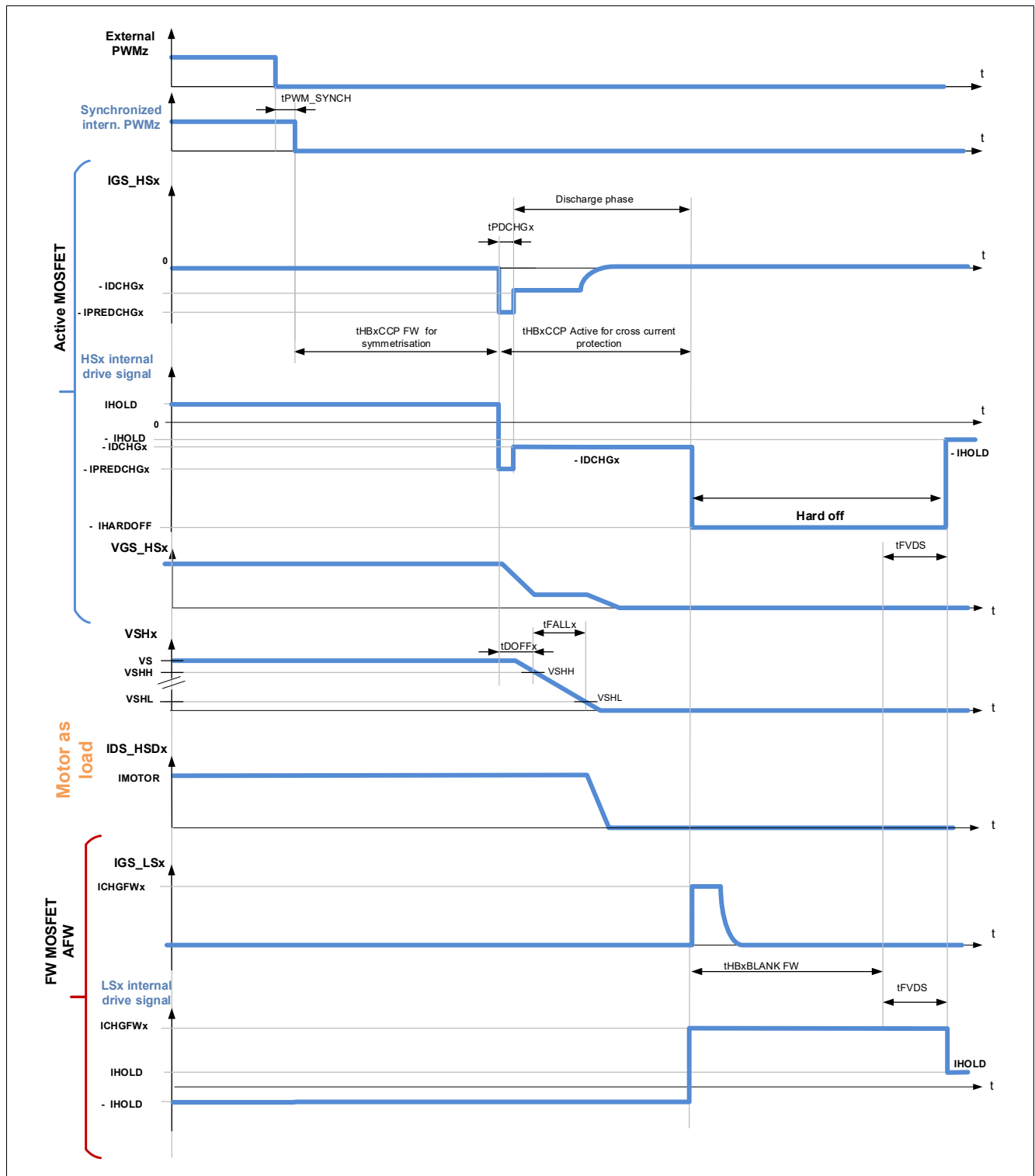

Figure 62 Adaptive turn-off with high-side PWM, AGC[1:0] = (1,0) or (1,1), AFWx=1, motor operating as load

Adaptive turn-off during high-side PWM

The turn-off of the high-side MOSFET is done in four phases (Refer to Figure 62):

1. **Turn-off delay time for symmetrization** of the PWM signal: The turn-off of HSx is delayed by $t_{HBxCCP\ FW}$ after the falling edge of PWMz, in order to compensate the distortion caused by the cross-current protection time at turn-on.

Gate Drivers

2. **Pre-discharge:** ¹⁾once tHBxCCP FW for symmetrization has elapsed, the gate of the high-side MOSFET x is pre-discharged with the current - IPREDCHGx for a duration tDPCHGx. IPREDCHGx is a device internal parameter, which is self-adaptive (See next phase).
3. **Discharge:** After tPREDCHGx, the pre-discharge current is decreased in absolute value from IPREDCHGx²⁾ down to IDCHGx. The effective tDOFF³⁾ is measured and compared to the configured tDOFFx for the automatic adaptation of IPREDCHGx (see **Adaptive control of pre-discharge current**). The discharge phase ends up at expiration of tHBxCCP active for cross-current protection.
4. **Cross-current protection phase:** The cross-current protection is concurrent to the pre-discharge and discharge of the high-side MOSFET. The cross-current protection phase starts when the turn-off delay for symmetrization ends up. It has the duration tHBxCCP active. During tHBxCCP active, the low-side MOSFETx is kept OFF. When tHBxCCP active has elapsed, the gate of the low-side MOSFET x is charged with the current ICHGFWx until the end of tFVDS, provided that $V_{SHx} < V_{SHL}$.

Adaptive control of pre-discharge current

Refer to **Chapter 12.3.6** for information on the pre-discharge currents.

The pre-discharge current IPREDCHGx is a self-adaptive parameter if AGC[1:0] = (1,0) or (1,1) (see **GENCTRL**). The TLE9562-3QX adapts the IPREDCHGx to match the measured t_{DOFFx} to the configured value.

IPREDCHGx is clamped between I_{DCHG0} (0.5 mA typ.) and ICHGMAXx (see **HB_ICHG_MAX**).

IPREDCHGx is initialized to Min(IPDCHGINITx, ICHGMAXx) when the TLE9562-3QX receives a SPI command setting HBx_PWM_EN to 1 (see **HBMODE**). IPDCHGINITx is set by the register **HB_PCHG_INIT**.

The pre-discharge current is increased or decreased by one, respectively by two current steps (**Chapter 12.3.6**) if the control bit IPCHGADT in the control register **GENCTRL** is set to 0 respectively 1.

The following adaptive schemes can be selected:

AGCFILT = 0: No filter is applied.

- If the effective tDOFFx is longer than the configured tDOFFx, then IPREDCHGx is increased during the next pre-discharge phase.
- If the effective tDOFFx is shorter than the configured tDOFFx, then IPREDCHGx is decreased during the next pre-discharge phase.
- The pre-charge current is increased or decreased by one, respectively by two current steps (**Chapter 12.3.6**) if the control bit IPCHGADT in the control register **GENCTRL** is set to 0 respectively 1.

AGCFILT = 1:

- If the effective tDOFFx **of the last two PWM cycles** are longer than the configured tDOFFx, then IPREDCHGx is increased during the next pre-discharge phase.
- If the effective tDOFFx **of the last two PWM cycles** are shorter than the configured tDOFFx, then IPREDCHGx is decreased during the next pre-discharge phase.
- If none of the two cases are applicable, then IPREDCHGx is unchanged during the next pre-discharge phase.

1) For a correct operation, it is required to configure tDPCHGx < tHBxCCPActive.

2) IPREDCHGx is clamped between ICHGMAXx and I_{DCHG0} .

3) The effective tDOFF can be read out.

Gate Drivers

- The pre-discharge current is increased or decreased by one, respectively by two current steps if the control bit IPCHGADT is set to 0 respectively 1.

12.3.4.1.2 High-side PWM with adaptive gate control and passive free-wheeling

This section describes the MOSFETs control scheme with passive free-wheeling (AFW_x = 0, **HBMODE**).

In contrast to the active free-wheeling, if AFW_x = 0, only the PWM MOSFET can be turned on, while the complementary MOSFET is always kept off.

Turn-on of the PWM MOSFET, AFW_x = 0

If AFW_x = 0, the cross-current protection time at the rising edge of the synchronized PWM signal is omitted in contrast to the active free-wheeling. The pre-charge, the charge and the post-charge phases are identical to the control scheme with active free-wheeling. Refer to **Figure 63**.

Turn-off of the PWM MOSFET, AFW_x = 0

If AFW_x = 0, the cross-current protection time at the falling edge of the synchronized PWM signal is omitted in contrast to the active free-wheeling. The pre-discharge, the discharge and the post-charge phases are identical to the control scheme with active free-wheeling. Refer to **Figure 64**.

Gate Drivers

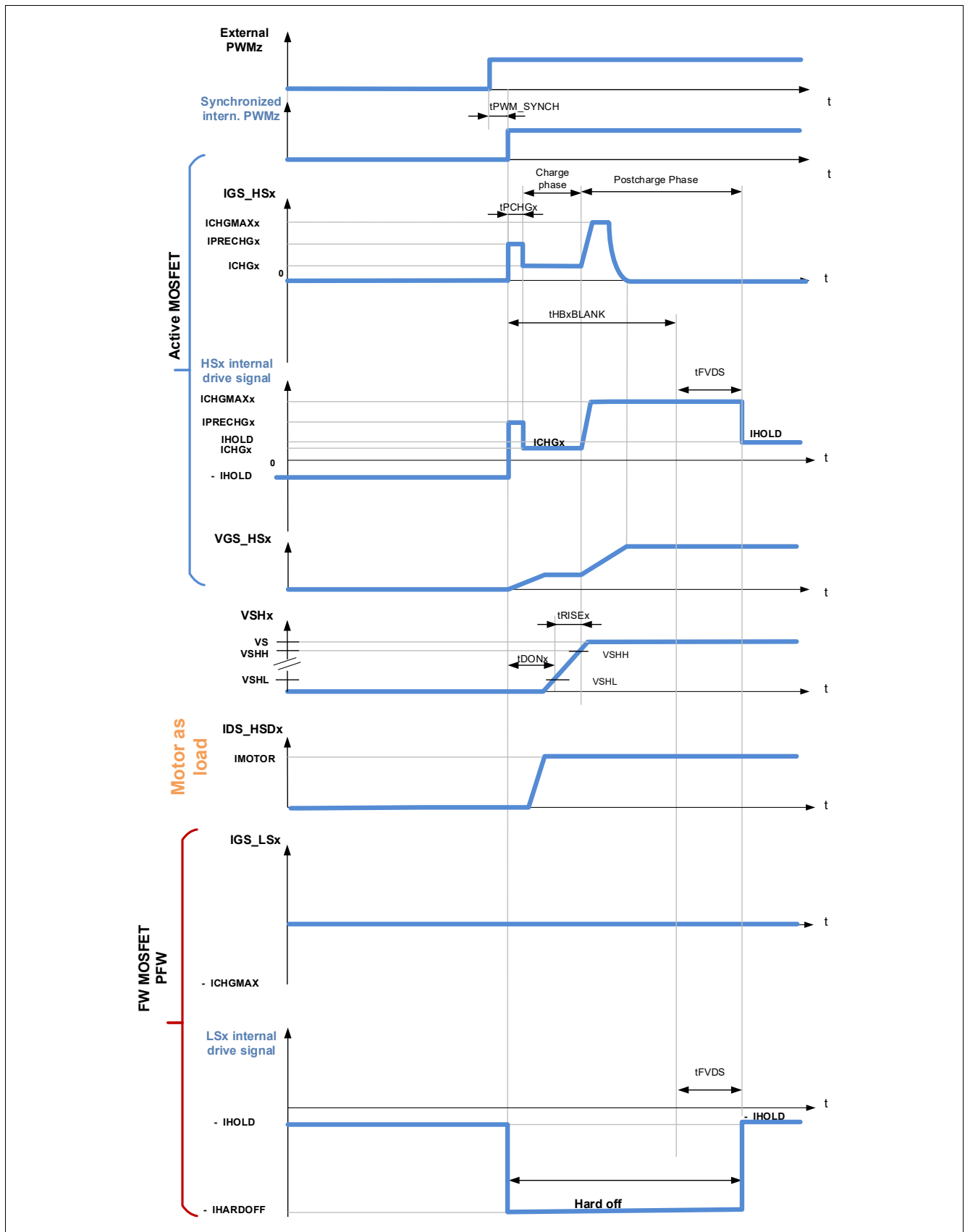

Figure 63 Adaptive turn-on with high-side PWM, AGC[1:0] = (1,0) or (1,1), AFWx=0, POCHGDIS=0, motor operating as load

Gate Drivers

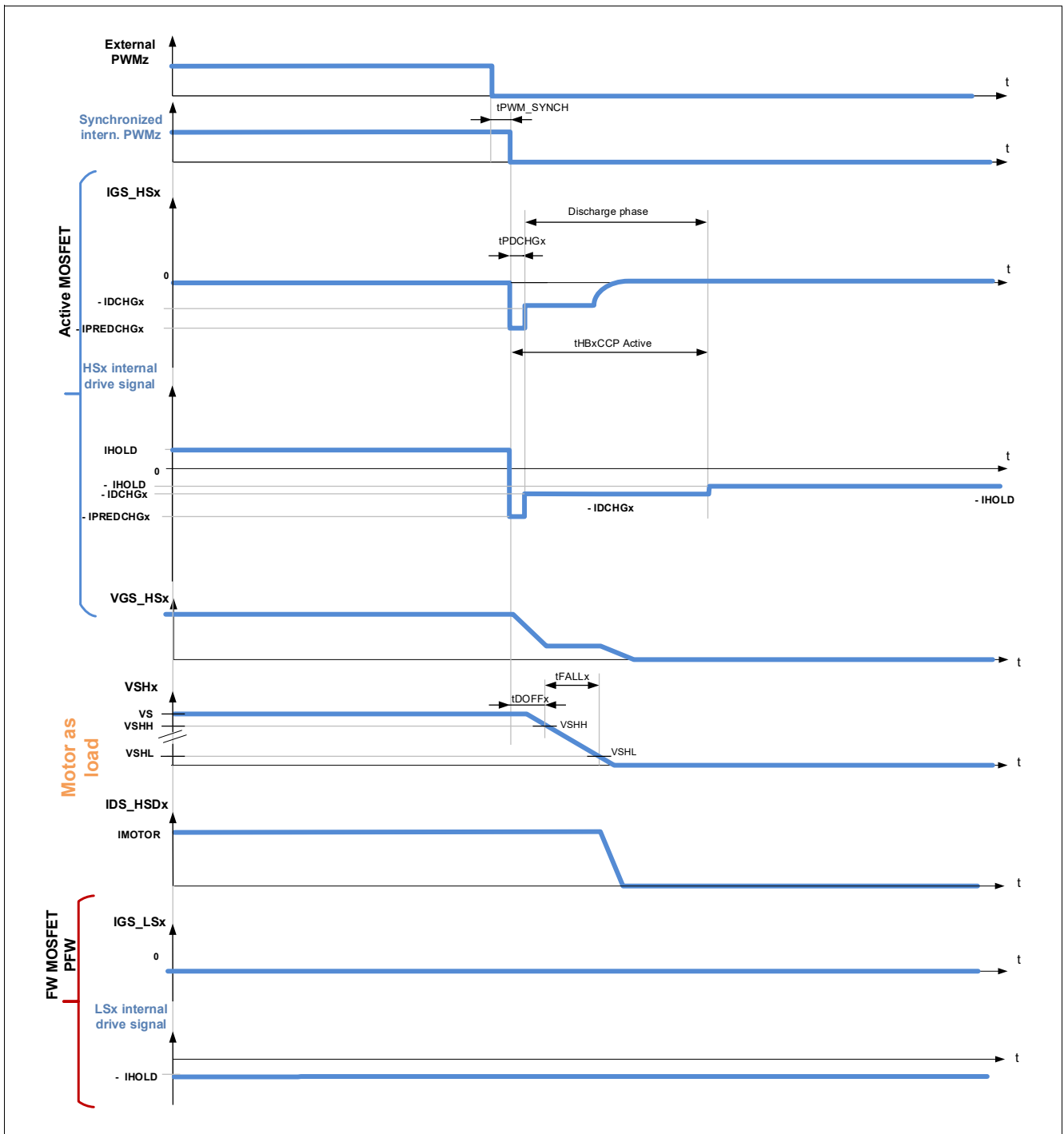

Figure 64 Adaptive turn-off with high-side PWM, AGC[1:0] = (1,0) or (1,1), AFWx=0, motor operating as load

Gate Drivers

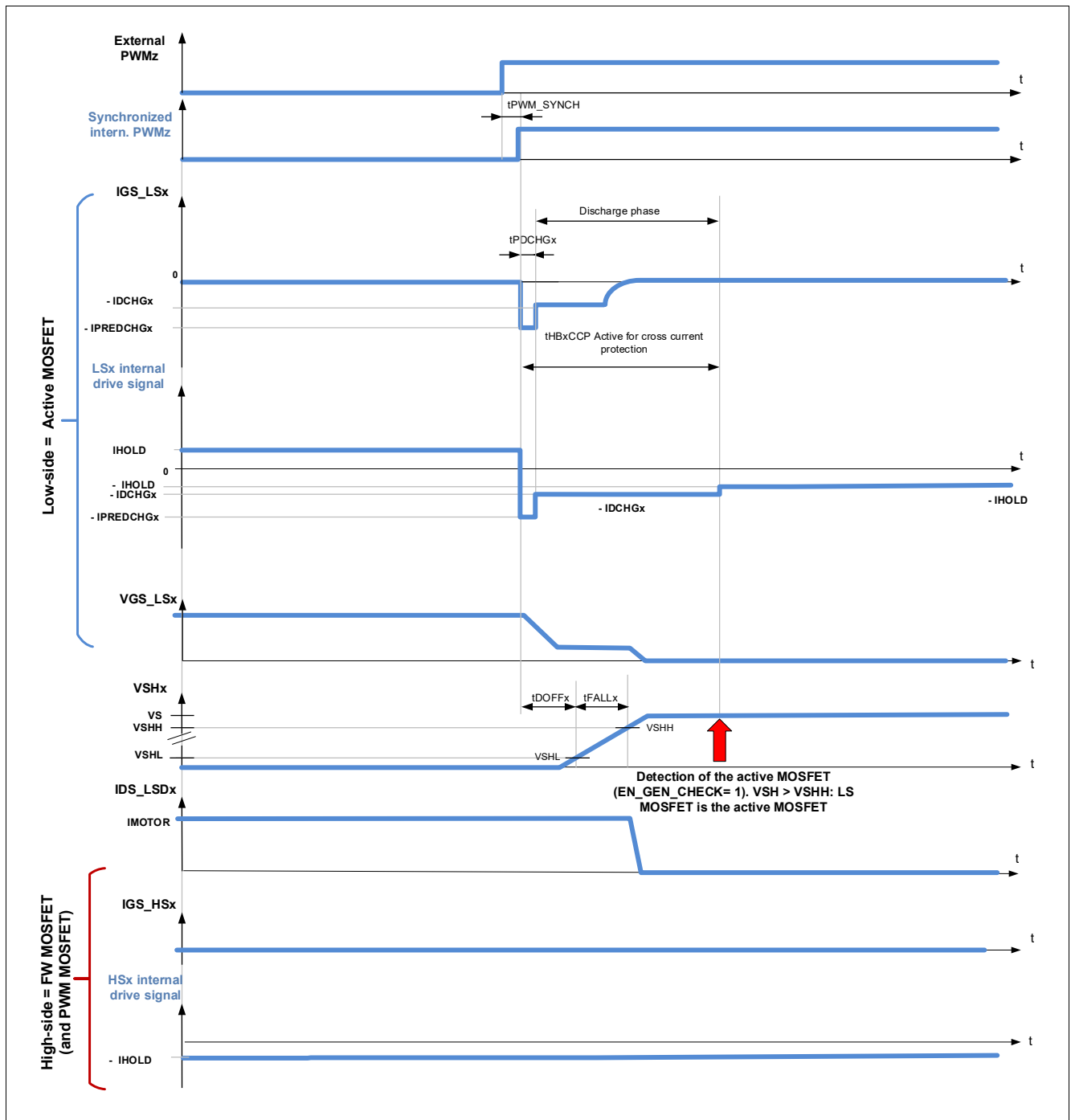

Figure 65 PWM rising edge in generator mode with high-side PWM, adaptive gate control on, AGC[1:0] = (1,0) or (1,1), AFWx=0, POCHGDIS=0. EN_GEN_CHECK = 1. The PWM MOSFET is the FW MOSFET

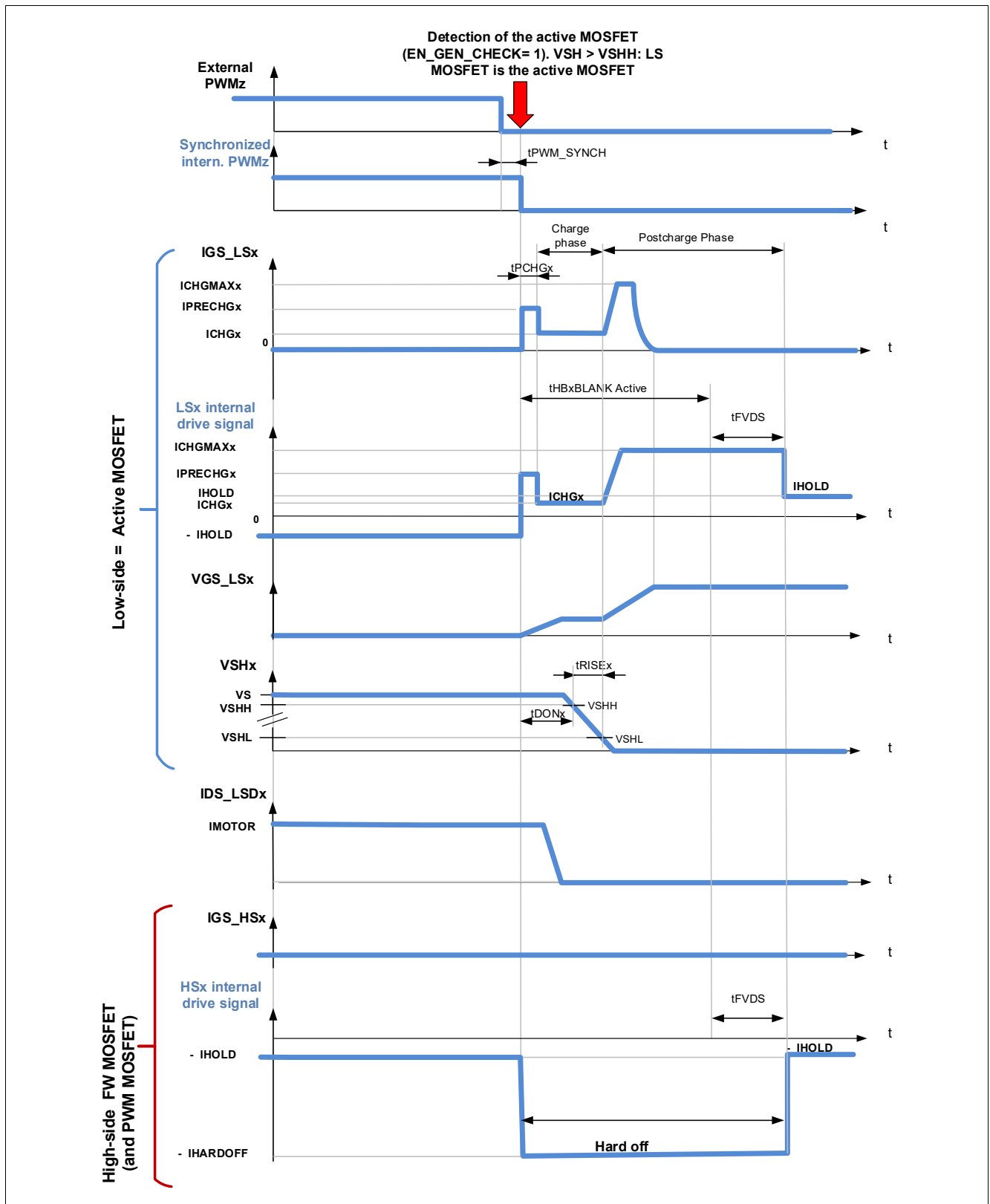

Figure 66 PWM falling edge in generator mode with high-side PWM, adaptive gate control on, AGC[1:0] = (1,0) or (1,1), AFWx=0, POCHGDIS=0. EN_GEN_CHECK = 1. The PWM MOSFET is the FW MOSFET

Gate Drivers

12.3.4.2 Low-side PWM with adaptive gate control, motor operating as load

The following section describes the MOSFET control when the PWM signal is applied to the low-side MOSFET of one half-bridge.

Assumption: the PWM channel z is applied to the low-side MOSFET of the half-bridge x (Figure 67).

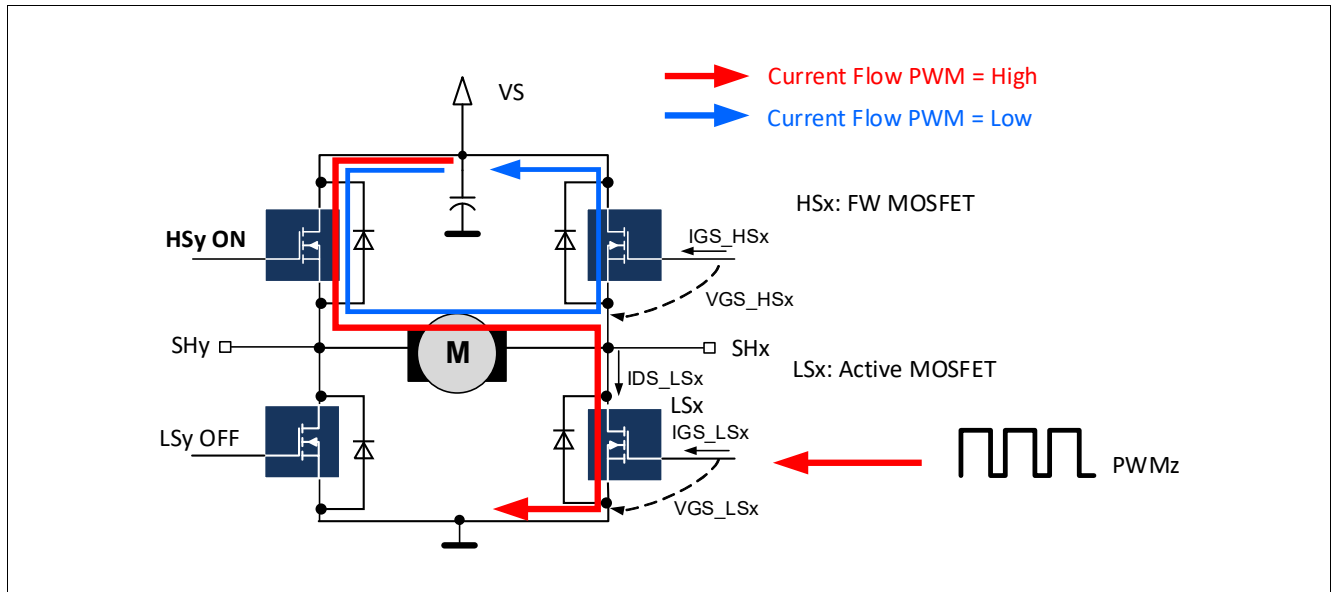

Figure 67 PWM Channel z is mapped to low-side x, motor operating as load

The description of the control of the PWM half-bridge differs from the description of Chapter 12.3.4.1 only by exchanging high-side x and low-side x and thresholds V_{SHH} and V_{SHL} .

12.3.4.3 High-side PWM with adaptive gate control, motor operating as generator

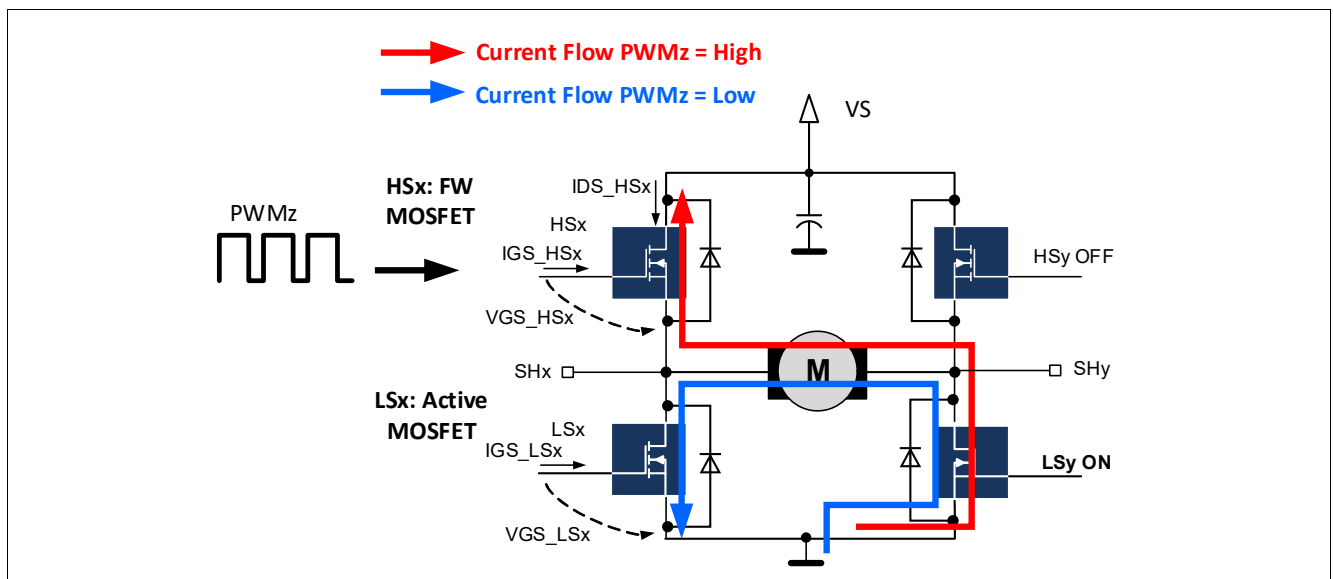

Figure 68 PWM input z is mapped to high-side x, the motor operating as generator

Gate Drivers

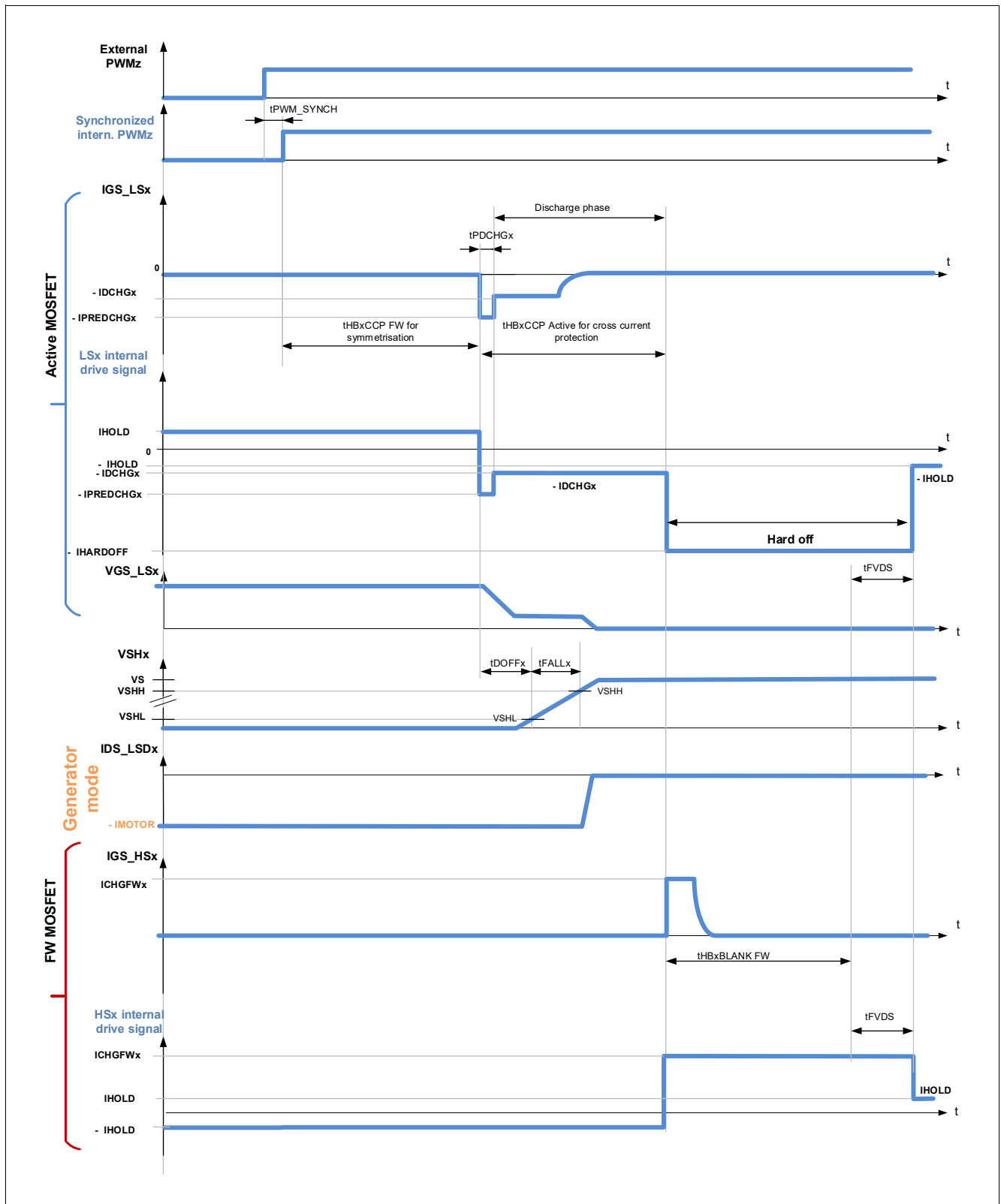

Figure 69 Adaptive turn-on with high-side PWM, AGC[1:0] = (1,0) or (1,1), AFWx=1, motor operating as generator

12.3.4.4 Low-side PWM with adaptive gate control, motor operating as generator

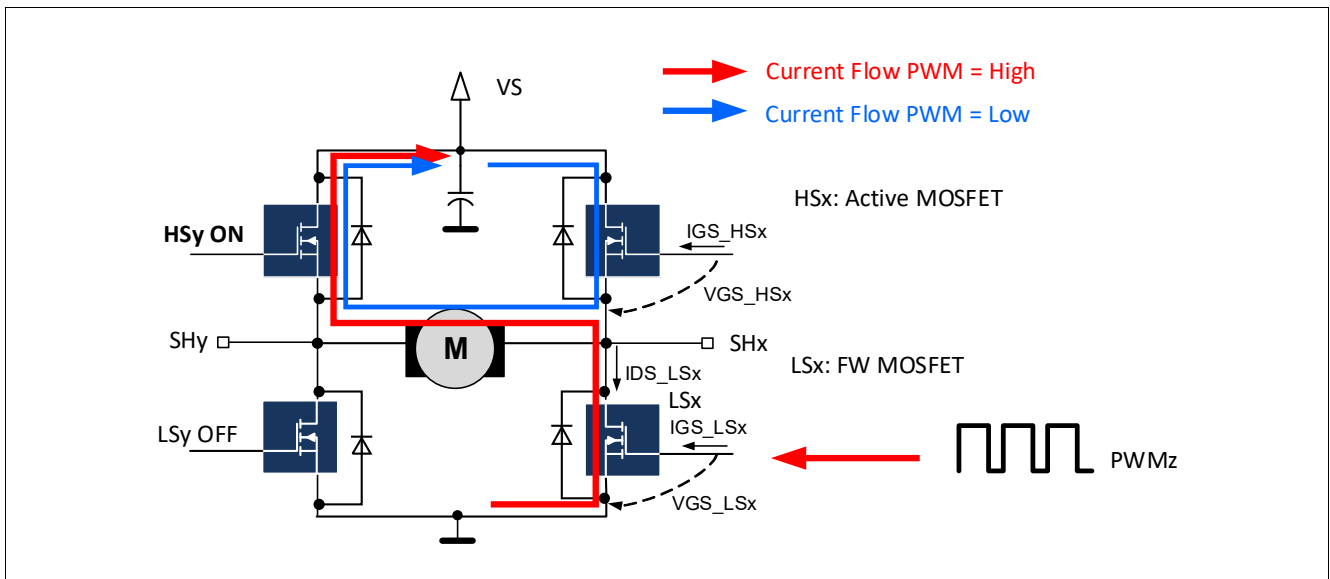

Figure 70 PWM input z is mapped to low-side x, the motor operating as generator

Gate Drivers

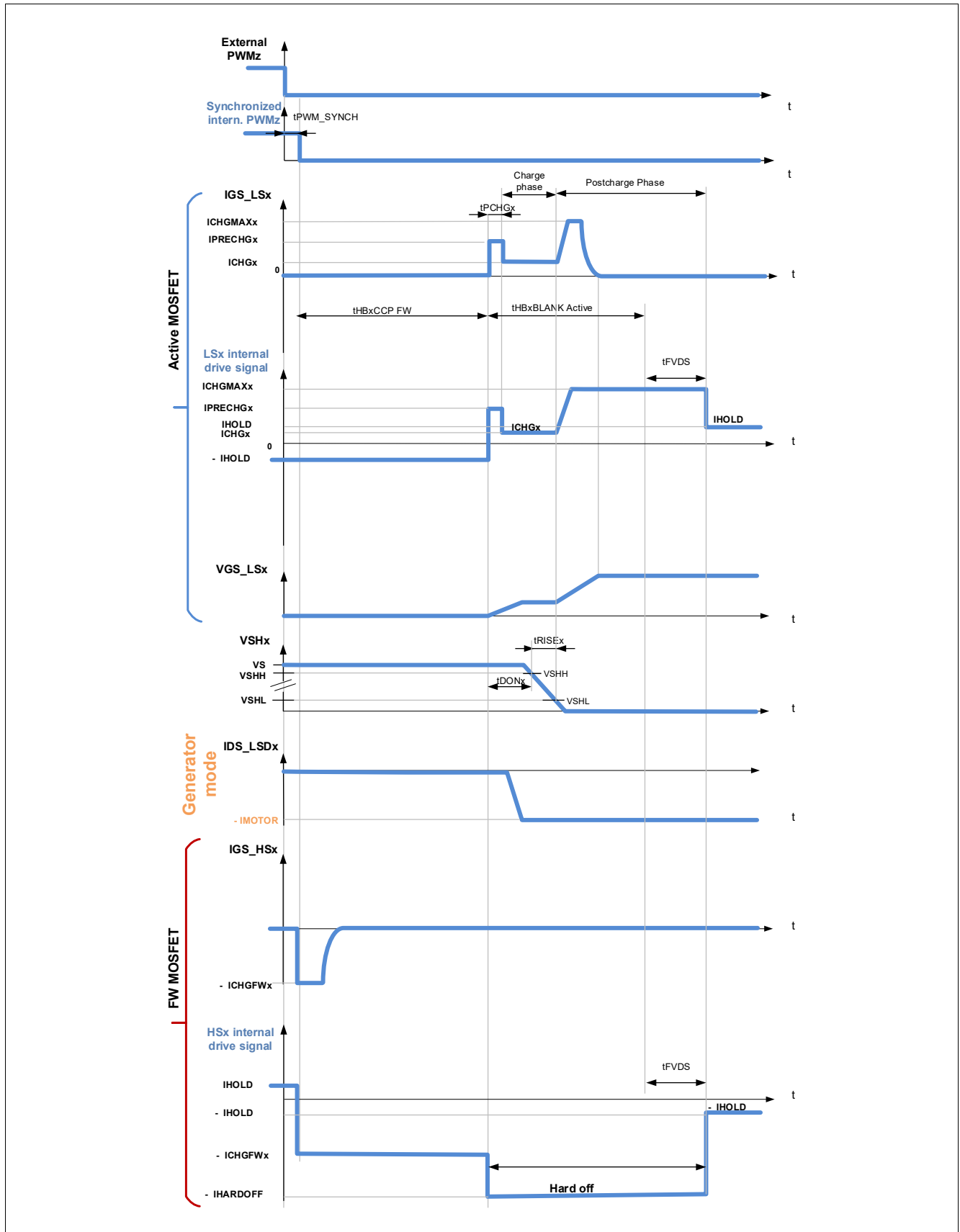

Figure 71 Adaptive turn-off with high-side PWM, AGC[1:0] = (1,0) or (1,1), AFWx=1, motor operating as generator and EN_GEN_CHECK = 1

12.3.4.5 Status bits for regulation of turn-on and turn-off delay times

The control bits TDREGx (**TDREG**) indicate if tDONx and tDOFFx of the half-bridge x, using the adaptive control scheme (**AGC** = 10_B or 11_B), are in regulation.

The half-bridge x is considered in regulation if one of the following conditions is met:

- Condition 1: The effective turn-on and turn-off delays are equal to the configured delays for at least eight cumulative PWM cycle (HBx tDON counter ≥ 8 and HBx tDOFF counter ≥ 8). For each PWM cycle
 - if $tDON_{xEFF}^{1)} = TDON_{x}^{2)}$: HBx tDON counter is incremented
 - if $tDON_{xEFF}^{1)} \neq TDON_{x}^{2)}$: HBx tDON counter is decremented
 - if $tDOFF_{xEFF}^{1)} = TDOFF_{x}^{3)}$: HBx tDOFF counter is incremented
 - if $tDOFF_{xEFF}^{1)} \neq TDOFF_{x}^{3)}$: HBx tDOFF counter is decremented
- Condition 2: The error between the effective delays ((tDON_xEFF-TDON_x) and (tDOFF_xEFF-TDOFF_x)) changes its sign three times consecutively

12.3.4.6 Time modulation of pre-charge and pre-discharge times

If **DEEP_ADAP** = 0:

- one single precharge current is applied during tPCHGx to regulate TDON
- one single precharge current is applied during tPDCHGx to regulate TDOFF

If **DEEP_ADAP** = 1 (“deep adaptation” or “time modulation”) it is possible to:

- to divide the precharge phase in two parts, during which two different precharge currents can be applied
- to divide the pre-discharge phase in two parts, during which two different precharge currents can be applied

Figure 72 describes the principle of the time modulation applied to the precharge phase. The same principle is also applied for the regulation of the pre-discharge phase.

1) Refer to **EFF_TDON_OFF1**, **EFF_TDON_OFF2**, **EFF_TDON_OFF3**, **EFF_TDON_OFF4**

2) Refer to **TDON_HB_CTRL**

3) Refer to **TDOFF_HB_CTRL**

Gate Drivers

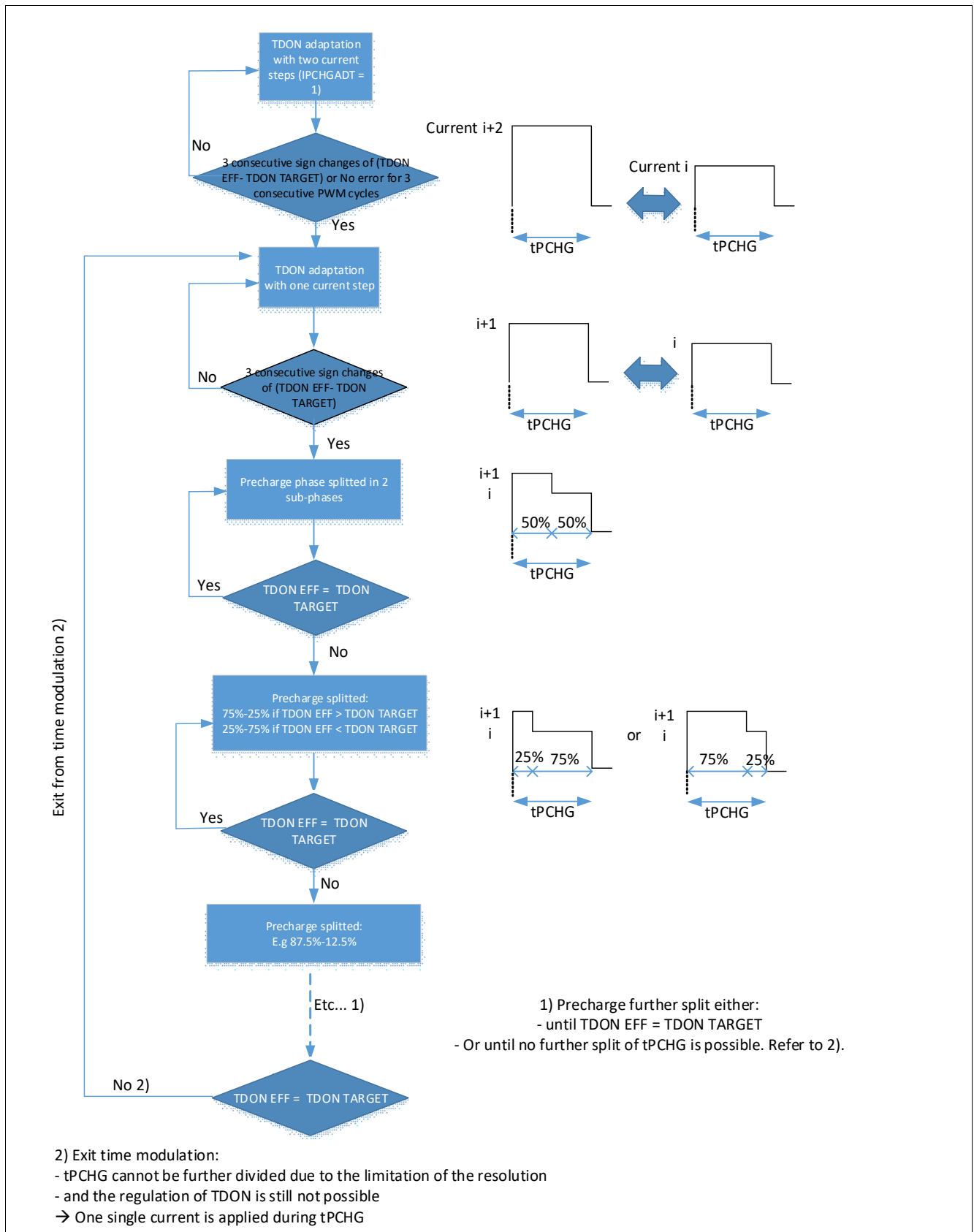

Figure 72 Principle of the time modulation of the precharge phase, DEEP_ADAP = 1, AGC = 10_B or 11_B

12.3.5 PWM operation without adaptive gate control

The adaptive gate control is disabled if AGC[1:0] is set to (0,0) or (0,1). The effective turn-on and turn-off delays of the PWM MOSFETs are not regulated. Two modes can be selected.

The target turn-on and turn-off delay times of PWM MOSFETs (configured in [TRISE_FALL1](#), [TRISE_FALL2](#), [TRISE_FALL3](#), [TRISE_FALL4](#)) are no longer regulated. Nevertheless the status registers [EFF_TDON_OFF1](#), [EFF_TDON_OFF2](#), [EFF_TDON_OFF3](#), [EFF_TDON_OFF4](#) still report the effective turn-on and turn-off times of the PWM MOSFET.

12.3.5.1 AGC[1:0]=00_B

When AGC[1:0] = (0,0) (see [GENCTRL](#)), the control of the gate drivers in PWM mode differs from the description of [Chapter 12.3.4, PWM operation with adaptive gate control](#), only by the suppression of the pre-charge and pre-discharge phases.

12.3.5.2 AGC[1:0]=01_B

When [AGC](#) = (0,1) (see [GENCTRL](#)), then:

- During the pre-charge phase (tDCHGx) the gate of the PWM MOSFET mapped to the PWM input z is charged with the current IPCHGINITx ([HB_PCHG_INIT](#)).
- During the pre-discharge phase (tPDCHGx), the gate of the PWM MOSFET mapped to the PWM input z is discharged with the current -IPDCHGINITx ([HB_PCHG_INIT](#)).

12.3.6 Gate driver current

Each gate driver is able to source and sink currents from 0.5 mA to 100 mA, with 64 steps according to [Figure 73](#) and [Figure 74](#).

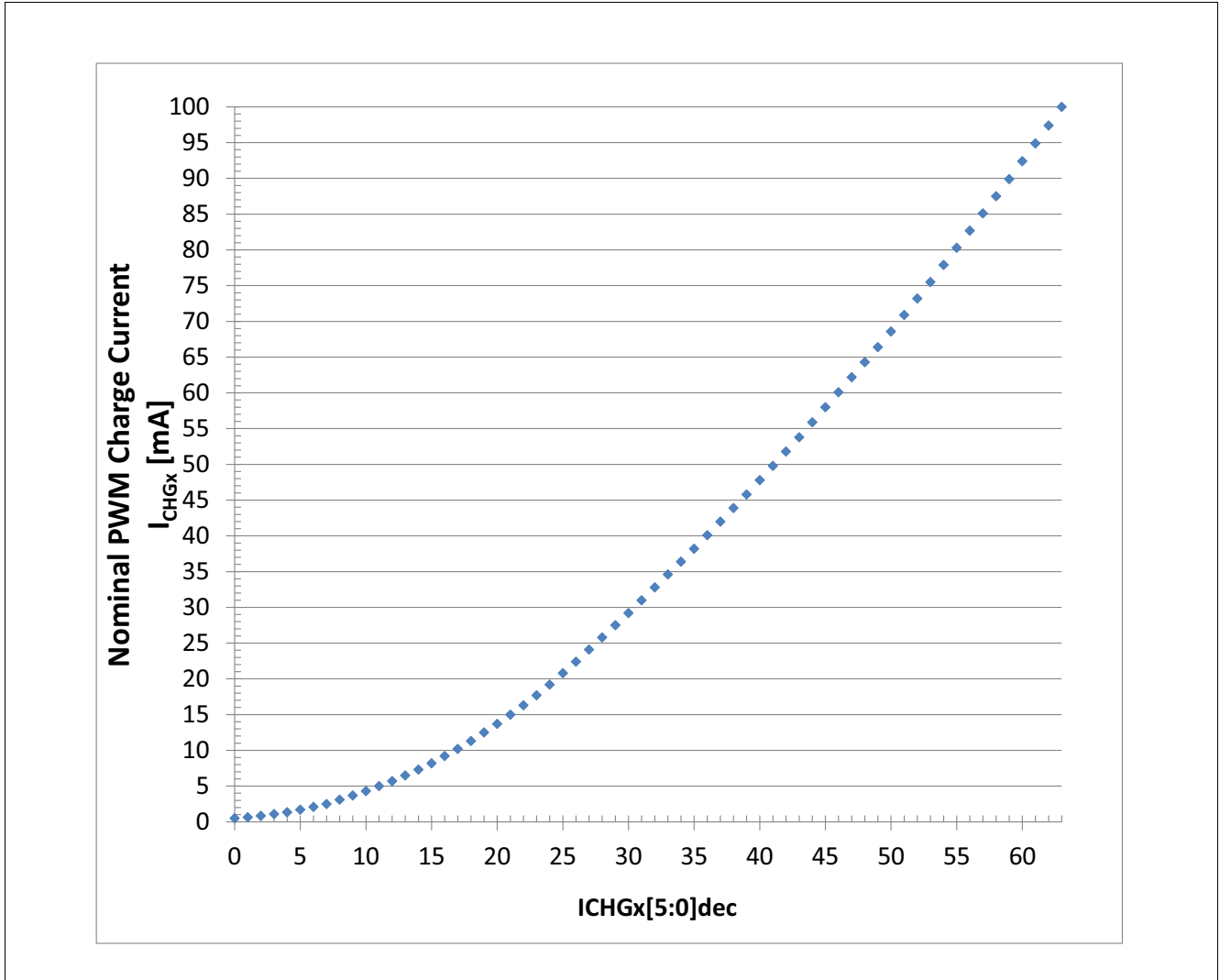

Figure 73 Configurable charge currents in PWM operation

Gate Drivers

Table 31 Charge currents in PWM operation, initial precharge current and freewheeling MOSFETs charge current

ICHGx[5:0], PCHGINIT[5:0]	Parameter name	Nom. charge current [mA]	Max. deviation to nominal values [%]
000000 _B	I_{CHG0}	0.5	+/- 60%
000001 _B	I_{CHG1}	0.65	+/- 60%
000010 _B	I_{CHG2}	0.85	+/- 60%
000011 _B	I_{CHG3}	1.1	+/- 60%
000100 _B	I_{CHG4}	1.35	+/- 60%
000101 _B	I_{CHG5}	1.7	+/- 60%
000110 _B	I_{CHG6}	2.1	+/- 60%
000111 _B	I_{CHG7}	2.5	+/- 60%
001000 _B	I_{CHG8}	3.1	+/- 55%
001001 _B	I_{CHG9}	3.7	+/- 55%
001010 _B	I_{CHG10}	4.3	+/- 55%
001011 _B	I_{CHG11}	5.0	+/- 55%
001100 _B	I_{CHG12}	5.7	+/- 55%
001101 _B	I_{CHG13}	6.5	+/- 55%
001110 _B	I_{CHG14}	7.3	+/- 40%
001111 _B	I_{CHG15}	8.2	+/- 40%
010000 _B	I_{CHG16}	9.2	+/- 40 %
010001 _B	I_{CHG17}	10.2	+/- 40 %
010010 _B	I_{CHG18}	11.3	+/- 40%
010011 _B	I_{CHG19}	12.5	+/- 40%
010100 _B	I_{CHG20}	13.7	+/- 40%
010101 _B	I_{CHG21}	15	+/- 40%
010110 _B	I_{CHG22}	16.3	+/- 40%
010111 _B	I_{CHG23}	17.7	+/- 40%
011000 _B	I_{CHG24}	19.2	+/- 40%
011001 _B	I_{CHG25}	20.8	+/- 40%
011010 _B	I_{CHG26}	22.4	+/- 40%
011011 _B	I_{CHG27}	24.1	+/- 40%
011100 _B	I_{CHG28}	25.8	+/- 40%
011101 _B	I_{CHG29}	27.5	+/- 40%
011110 _B	I_{CHG30}	29.2	+/- 30%
011111 _B	I_{CHG31}	31	+/- 30%
100000 _B	I_{CHG32}	32.8	+/- 30%
100001 _B	I_{CHG33}	34.6	+/- 30%
100010 _B	I_{CHG34}	36.4	+/- 30%
100011 _B	I_{CHG35}	38.2	+/- 30%

Gate Drivers

Table 31 Charge currents in PWM operation, initial precharge current and freewheeling MOSFETs charge current (cont'd)

ICHGx[5:0], PCHGINIT[5:0]	Parameter name	Nom. charge current [mA]	Max. deviation to nominal values [%]
100100 _B	I_{CHG36}	40.1	+/- 30%
100101 _B	I_{CHG37}	42	+/- 30%
100110 _B	I_{CHG38}	43.9	+/- 30%
100111 _B	I_{CHG39}	45.8	+/- 30%
101000 _B	I_{CHG40}	47.8	+/- 30%
101001 _B	I_{CHG41}	49.8	+/- 30%
101010 _B	I_{CHG42}	51.8	+/- 30%
101011 _B	I_{CHG43}	53.8	+/- 30%
101100 _B	I_{CHG44}	55.9	+/- 30%
101101 _B	I_{CHG45}	58	+/- 30%
101110 _B	I_{CHG46}	60.1	+/- 30%
101111 _B	I_{CHG47}	62.2	+/- 30%
110000 _B	I_{CHG48}	64.3	+/- 30%
110001 _B	I_{CHG49}	66.4	+/- 30%
110010 _B	I_{CHG50}	68.6	+/- 30%
110011 _B	I_{CHG51}	70.9	+/- 30%
110100 _B	I_{CHG52}	73.2	+/- 30%
110101 _B	I_{CHG53}	75.5	+/- 30%
110110 _B	I_{CHG54}	77.9	+/- 30%
110111 _B	I_{CHG55}	80.3	+/- 30%
111000 _B	I_{CHG56}	82.7	+/- 30%
111001 _B	I_{CHG57}	85.1	+/- 30%
111010 _B	I_{CHG58}	87.5	+/- 30%
111011 _B	I_{CHG59}	89.9	+/- 30%
111100 _B	I_{CHG60}	92.4	+/- 30%
111101 _B	I_{CHG61}	94.9	+/- 30%
111110 _B	I_{CHG62}	97.4	+/- 30%
111111 _B	I_{CHG63}	100	+/- 30%

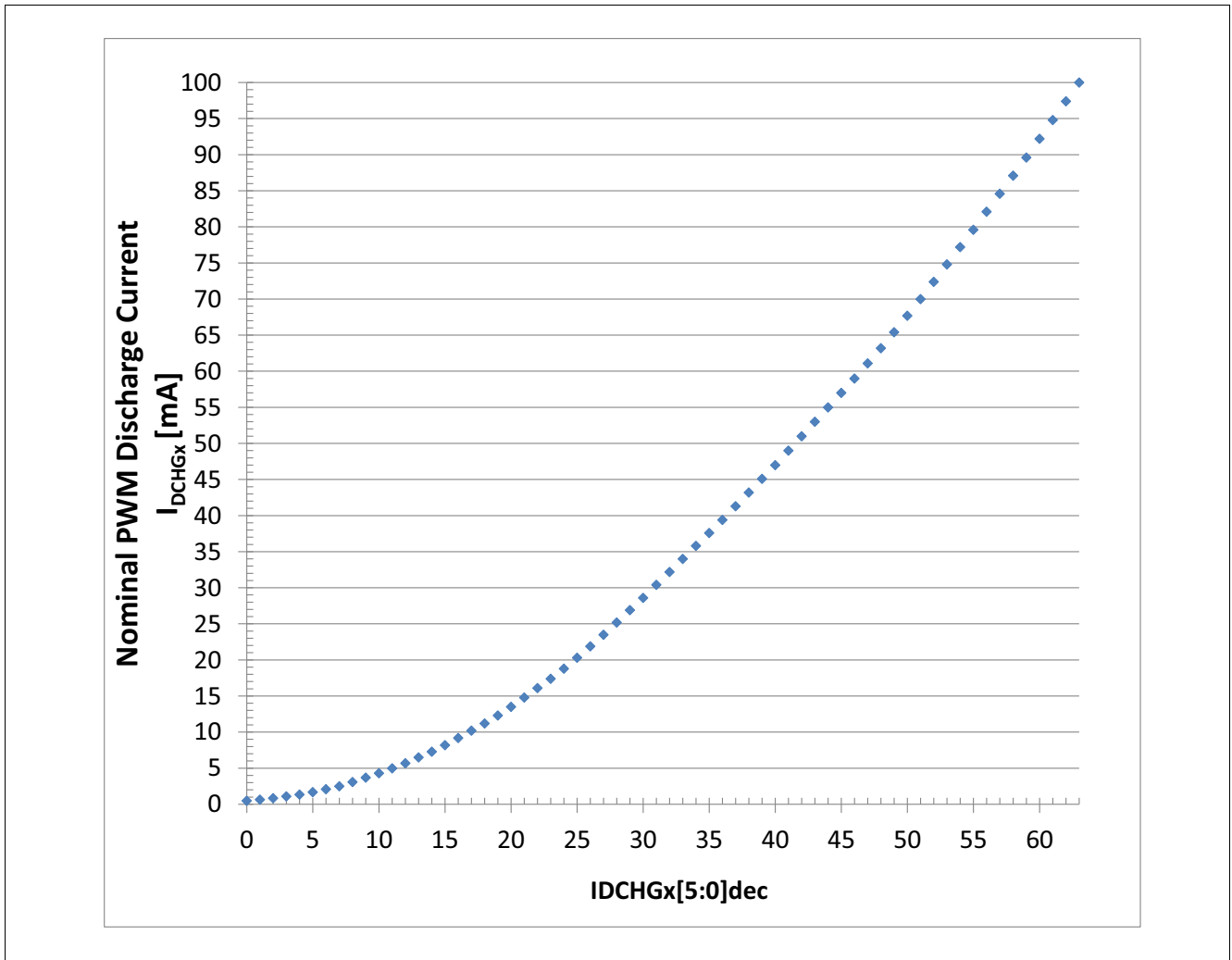

Figure 74 Configurable discharge currents in PWM operation

Gate Drivers

Table 32 Discharge currents in PWM operation, initial predischage current and freewheeling MOSFETs discharge current

IDCHGx[5:0], PDCHGINIT[5:0]	Parameter name	Nom. discharge current [mA]	Max. deviation to nominal values [%]
00000 _B	I_{DCHG0}	0.5	+/- 60%
00001 _B	I_{DCHG1}	0.65	+/- 60%
00010 _B	I_{DCHG2}	0.85	+/- 60%
00011 _B	I_{DCHG3}	1.1	+/- 60%
00100 _B	I_{DCHG4}	1.35	+/- 60%
00101 _B	I_{DCHG5}	1.7	+/- 60%
00110 _B	I_{DCHG6}	2.1	+/- 60%
00111 _B	I_{DCHG7}	2.5	+/- 60%
01000 _B	I_{DCHG8}	3.1	+/- 55%
01001 _B	I_{DCHG9}	3.7	+/- 55%
01010 _B	I_{DCHG10}	4.3	+/- 55%
01011 _B	I_{DCHG11}	5.0	+/- 55%
01100 _B	I_{DCHG12}	5.7	+/- 55%
01101 _B	I_{DCHG13}	6.5	+/- 55%
01110 _B	I_{DCHG14}	7.3	+/- 40%
01111 _B	I_{DCHG15}	8.2	+/- 40%
10000 _B	I_{DCHG16}	9.2	+/- 40%
10001 _B	I_{DCHG17}	10.2	+/- 40%
10010 _B	I_{DCHG18}	11.2	+/- 40%
10011 _B	I_{DCHG19}	12.3	+/- 40%
10100 _B	I_{DCHG20}	13.5	+/- 40%
10101 _B	I_{DCHG21}	14.8	+/- 40%
10110 _B	I_{DCHG22}	16.1	+/- 40%
10111 _B	I_{DCHG23}	17.4	+/- 40%
11000 _B	I_{DCHG24}	18.8	+/- 40%
11001 _B	I_{DCHG25}	20.3	+/- 40%
11010 _B	I_{DCHG26}	21.9	+/- 40%
11011 _B	I_{DCHG27}	23.5	+/- 40%
11100 _B	I_{DCHG28}	25.2	+/- 40%
11101 _B	I_{DCHG29}	26.9	+/- 40%
11110 _B	I_{DCHG30}	28.6	+/- 30%
11111 _B	I_{DCHG31}	30.4	+/- 30%
10000 _B	I_{DCHG32}	32.2	+/- 30%
10001 _B	I_{DCHG33}	34	+/- 30%
10010 _B	I_{DCHG34}	35.8	+/- 30%
10011 _B	I_{DCHG35}	37.6	+/- 30%

Gate Drivers

Table 32 Discharge currents in PWM operation, initial predischage current and freewheeling MOSFETs discharge current (cont'd)

IDCHGx[5:0], PDCHGINIT[5:0]	Parameter name	Nom. discharge current [mA]	Max. deviation to nominal values [%]
100100 _B	I_{DCHG36}	39.4	+/- 30 %
100101 _B	I_{DCHG37}	41.3	+/- 30 %
100110 _B	I_{DCHG38}	43.2	+/- 30 %
100111 _B	I_{DCHG39}	45.1	+/- 30 %
101000 _B	I_{DCHG40}	47	+/- 30 %
101001 _B	I_{DCHG41}	49	+/- 30 %
101010 _B	I_{DCHG42}	51	+/- 30 %
101011 _B	I_{DCHG43}	53	+/- 30 %
101100 _B	I_{DCHG44}	55	+/- 30 %
101101 _B	I_{DCHG45}	57	+/- 30 %
101110 _B	I_{DCHG46}	59	+/- 30 %
101111 _B	I_{DCHG47}	61.1	+/- 30 %
110000 _B	I_{DCHG48}	63.2	+/- 30 %
110001 _B	I_{DCHG49}	65.4	+/- 30 %
110010 _B	I_{DCHG50}	67.7	+/- 30 %
110011 _B	I_{DCHG51}	70	+/- 30 %
110100 _B	I_{DCHG52}	72.4	+/- 30 %
110101 _B	I_{DCHG53}	74.8	+/- 30 %
110110 _B	I_{DCHG54}	77.2	+/- 30 %
110111 _B	I_{DCHG55}	79.6	+/- 30 %
111000 _B	I_{DCHG56}	82.1	+/- 30 %
111001 _B	I_{DCHG57}	84.6	+/- 30 %
111010 _B	I_{DCHG58}	87.1	+/- 30 %
111011 _B	I_{DCHG59}	89.6	+/- 30 %
111100 _B	I_{DCHG60}	92.2	+/- 30 %
111101 _B	I_{DCHG61}	94.8	+/- 30 %
111110 _B	I_{DCHG62}	97.4	+/- 30 %
111111 _B	I_{DCHG63}	100	+/- 30 %

12.3.7 PWM operation at high and low duty cycles with active freewheeling

This section describes the internal PWM signal of the active and FW MOSFET when the motor operates as load or generator with active freewheeling (AFWx = 1). In particular, at low and high duty cycles, the active freewheeling is disabled.

Notes

1. It is recommended to clear **EN_GEN_CHECK** (**EN_GEN_CHECK** to 0) at very high and very low duty cycles: $t_{ON} < t_{HBxCCP\ FW}$ or $t_{OFF} < t_{HBxCCP\ active}$. Under these conditions, a generator mode cannot be correctly detected. The control scheme of the active MOSFET and of the freewheeling MOSFET can therefore be inverted.
2. The device cannot measure the switching times t_{DON} , t_{DOFF} , t_{RISE} and t_{FALL} at very high and very low duty cycles: $t_{ON} < t_{HBxCCP\ FW}$ or $t_{OFF} < t_{HBxCCP\ active}$.

General case, motor operating as load, $t_{ON} > t_{HBxCCP\ FW}$ and $t_{OFF} > t_{HBxCCP\ FW} + t_{HBxCCP\ active}$

Figure 75 shows the internal control signals of the PWM MOSFETs and the freewheeling MOSFET while the motor operates as load:

- t_{ON} is longer than the FW cross-current protection time ($t_{HBxCCP\ FW}$).
- t_{OFF} is longer than the active cross-current protection time ($t_{HBxCCP\ FW} + t_{HBxCCP\ Active}$).

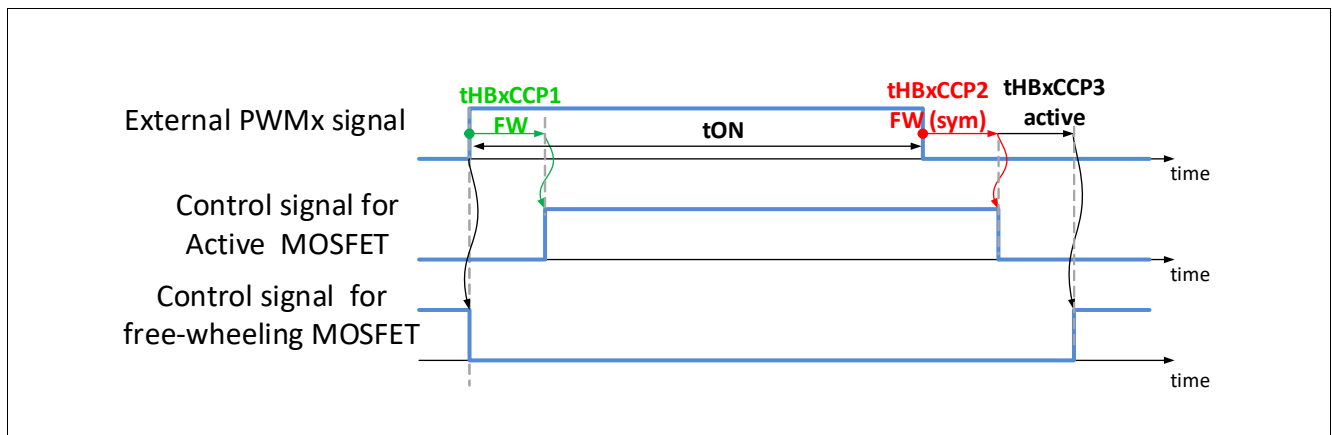

Figure 75 Internal signals for PWM operation - General case $t_{ON} > t_{HBxCCP\ FW}$, $t_{OFF} > t_{HBxCCP\ FW} + t_{HBxCCP\ active}$, motor operating as load

General case, motor operating as generator, $t_{OFF} > t_{HBxCCP\ FW}$ and $t_{ON} > t_{HBxCCP\ FW} + t_{HBxCCP\ active}$

Figure 76 shows the internal control signals of the PWM MOSFETs and the freewheeling MOSFET while the motor operates as generator:

- t_{OFF} is longer than the FW cross-current protection time ($t_{HBxCCP\ FW}$).
- t_{ON} is longer than the active cross-current protection time ($t_{HBxCCP\ FW} + t_{HBxCCP\ Active}$).

Gate Drivers

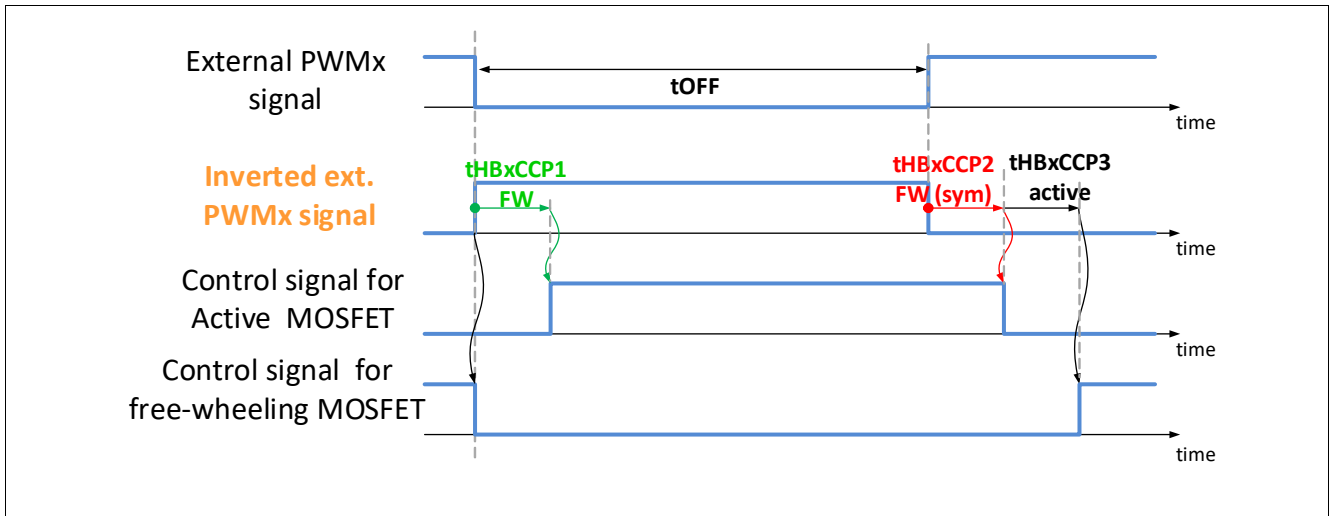

Figure 76 Internal signals for PWM operation - General case: $t_{OFF} > t_{HBxCCP} FW$, $t_{ON} > t_{HBxCCP} FW + t_{HBxCCP} FW$, Motor operating as generator

Gate Drivers

High duty cycle: $t_{OFF} < t_{HBxCCP\ active}$

No distinction between active MOSFET and FW MOSFET is possible, when the OFF-time of the external PWM signal is shorter than the configured active cross-current protection time. Therefore the PWM MOSFET (selected by HBxMODE[1:0]) is controlled as the active MOSFET. In other words, it is assumed that the motor operates as load. The control signal of the PWM MOSFET is shifted by one FW cross-current protection time compared to the external PWM signal. The MOSFET opposite to the PWM MOSFET stays OFF (passive FW).

Refer to [Figure 77](#).

Note: No active FW is applied if $t_{OFF} < t_{HBxCCP\ FW} + t_{HBxCCP\ active}$

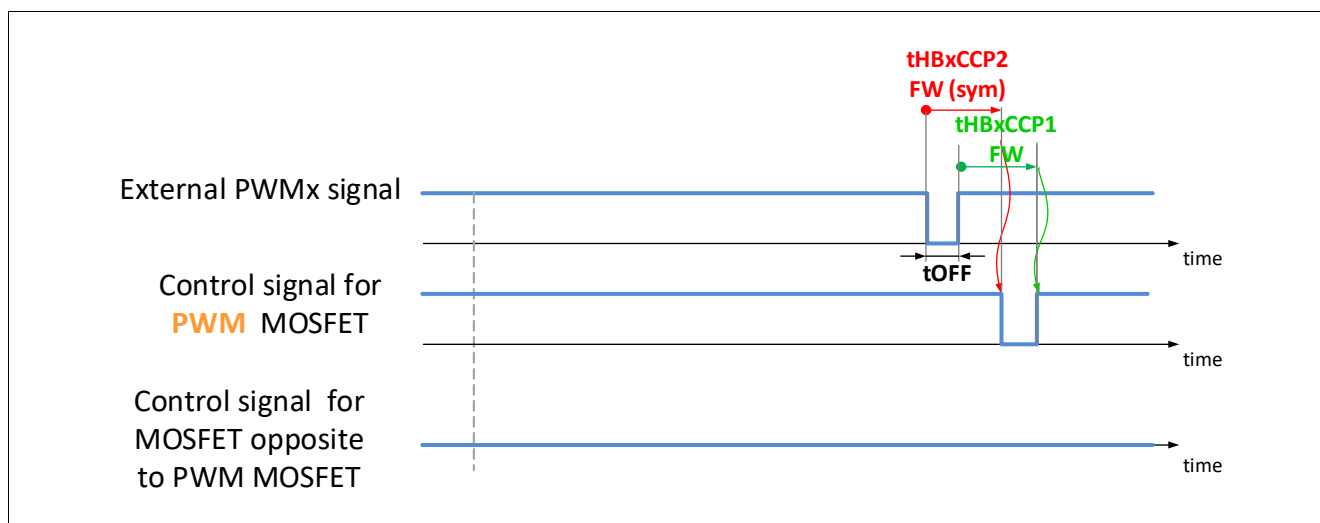

Figure 77 Internal signals for PWM operation at high duty cycle, $t_{OFF} < t_{HBxCCP\ Active} + t_{HBxCCP\ FW}$

Low duty cycle: $t_{ON} < t_{HBxCCP\ FW}$

No distinction between active MOSFET and FW MOSFET is possible, when the ON-time of the external PWM signal is shorter than the configured FW cross-current protection time. Therefore the PWM MOSFET (selected by HBxMODE[1:0]) is controlled as the active MOSFET. In other words, it is assumed that the motor operates as load. The control signal of the PWM MOSFET is shifted by one cross-current protection time compared to the external PWM signal.

Refer to [Figure 78](#).

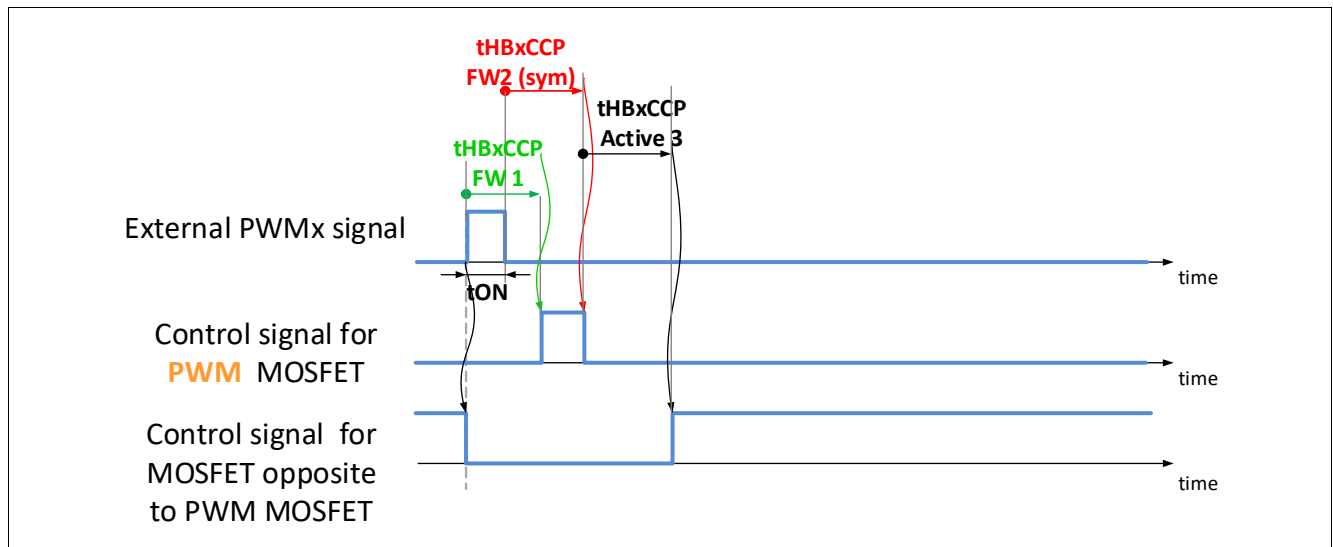

Figure 78 Internal signals for PWM operation at low duty cycle, $t_{ON} < t_{HBxCCP} FW$

12.3.8 Measurements of the switching times

The effective switching times in PWM operation:

- of the PWM MOSFET if **EN_GEN_CHECK** = 0
- of the active MOSFET if **EN_GEN_CHECK** = 1

are reported in the registers:

EFF_TDON_OFF1, EFF_TDON_OFF2, EFF_TDON_OFF3, EFF_TDON_OFF4.

If the end of the rise time for a given MOSFET is not detected before $t_{HBxBLANK} Active$ elapses, then the corresponding status register reports an effective rise time equal to zero.

If the end of the fall time for a given MOSFET is not detected before $t_{HBxCCP} Active$ elapses, then the corresponding status register reports an effective fall time equal to zero.

The device cannot measure the switching times t_{DON} , t_{DOFF} , t_{RISE} and t_{FALL} at very high and very low duty cycles: $t_{ON} < t_{HBxCCP} FW$ and $t_{OFF} < t_{HBxCCP} active$. In this case, the corresponding registers report effective t_{DON} , t_{DOFF} , t_{RISE} and t_{FALL} equal to zero.

12.4 Passive discharge

Resistors (R_{GGND}) between the gate of GHx and GND, and between GLx and GND, ensure that the external MOSFETs are turned off in the following conditions:

- V_{CC1} undervoltage
- HBxMODE = 00_B in Normal Mode
- **CPEN** = 0 in Normal Mode
- VS overvoltage or VSINT overvoltage
- Charge pump undervoltage and charge pump blank time ($t_{CPUVBLANK}$)
- Charge pump overtemperature (**CP_OT**)
- VDS overvoltage after active discharge in Normal Mode

Gate Drivers

- In Init Mode, Stop Mode, Fail Safe Mode, Restart Mode and Sleep Mode (exceptions for low-sides in parking braking and VS / VSINT overvoltage braking , refer to [Chapter 12.6](#) and [Chapter 13.11.3](#))

12.5 Slam mode

The slam mode is applicable in Normal Mode.

If the SLAM bit is set in **BRAKE** register:

1. If HBxMODE = 01b or 10b , then the corresponding MOSFETs are actively turned off with their static discharge current during their respective tHBxCCP Active.
2. Then charge pump is deactivated independently from **CPEN**
3. Then PWM1/CRC input pin is mapped to LS1, LS2, LS3 and LS4, independently from PMW12MAP, PWM34MAP, HBxMODE and HBx_PWM_EN
 - a) If PWM1/CRC is High, then the low-side MOSFETs are turned on within t_{ON_BRAKE} .
 - b) If PWM1/CRC is Low, then the low-side MOSFETs are turned off within t_{OFF_BRAKE} .

There is also the possibility to disable selectively the LSx in SLAM mode.

12.6 Parking braking mode

If **PARK_BRK_EN** bit is set, while the device goes in Sleep Mode or in Stop Mode:

1. If HBxMODE = 01b or 10b , then the corresponding MOSFETs are actively turned off with their static discharge current during their respective tHBxCCP Active.
2. Then charge pump is deactivated independently from CPEN bit.
3. Then the passive discharge (R_{GGND}) of the low-sides is deactivated, the passive discharge of the high-sides are activated
4. If PWM1/CRC is High, then the low-side MOSFETs are turned on within t_{ON_BRAKE} .

Refer to [Chapter 13.11.2](#) for the protection of the of low-side MOSFETs against short circuits when the parking braking mode is activated.

Gate Drivers

12.7 Charge pump

A dual-stage charge pump supplies the gate drivers for the high-side and low-side MOSFETs. It requires three external capacitors connected between CPC1N and CPC1P, CPC2N and CPC2P, VS and CP.

The buffer capacitor between VS and CP must have a capacitance equal or higher than 470 nF.

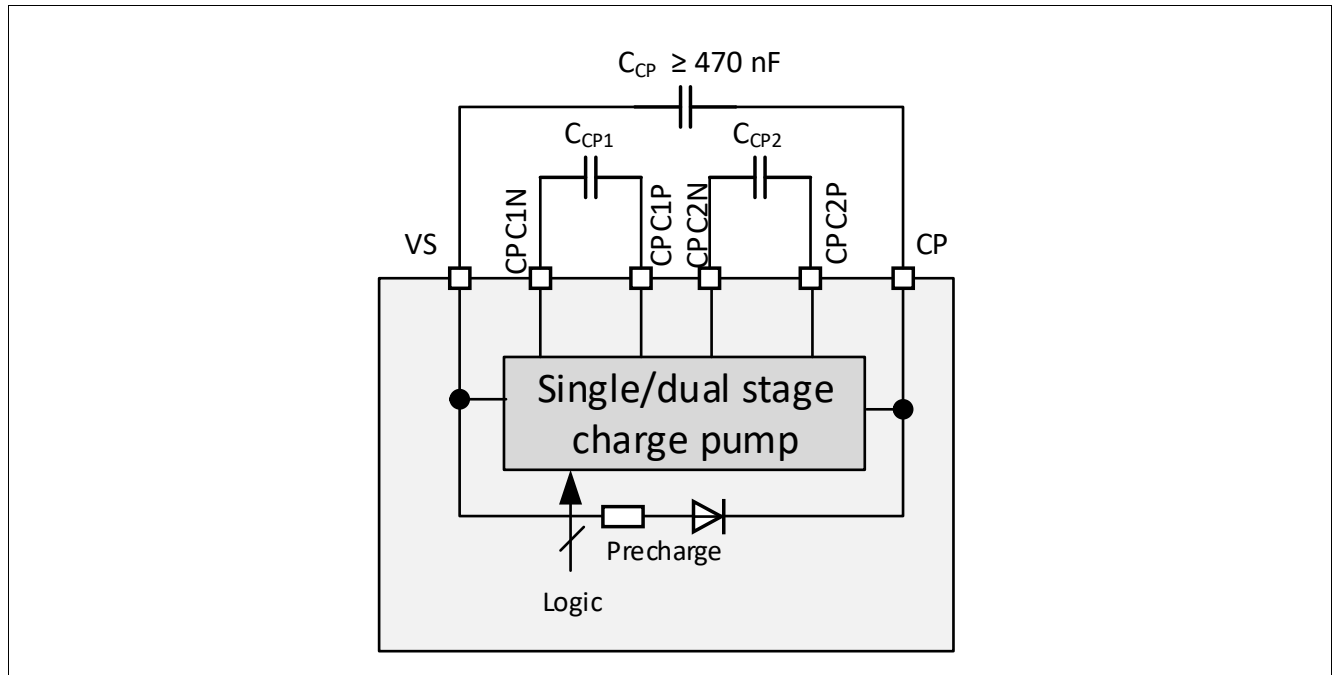

Figure 79 Charge pump - Block diagram

Logic or normal level MOSFETs

The regulation of the charge pump outputs voltage can be configured depending on the type of MOSFET.

FET_LVL = 0: Logic level MOSFETs are selected:

- $V_{CP} - V_S = V_{CP3}$ (11 V typ. at $V_S > 8$ V).
- The high-side gate-source voltage $G_{Hx} - S_{Hx}$ is V_{GH4} ($V_S > 8$ V).
- The low-side gate-source voltage $G_{Lx} - S_{Lx}$ is V_{GH3} ($V_S > 8$ V).

FET_LVL = 1: Normal level MOSFETs are selected:

- $V_{CP} - V_S = V_{CP1}$ (15 V typ. at $V_S > 8$ V).
- The high-side and low-side gate-source voltage $G_{Hx} - S_{Hx}$ or $G_{Lx} - S_{Lx}$ is V_{GH1} ($V_S > 8$ V).

$CPSTGA = 0$ (default, see **GENCTRL**), the device operates with the dual-stage charge pump.

If $CPSTGA = 1$, the device switches to single-stage or dual-stage charge pump automatically:

- If $V_S > V_{CPSO_{DS}}$: the TLE9562-3QX switches from a dual-stage to a single-stage charge pump.
- If $V_S < V_{CPSO_{SD}}$: the TLE9562-3QX switches from single-stage to dual-stage charge pump.

The operation with the single-stage charge pump reduces the current consumption from the VS pin.

12.8 Frequency modulation

A modulation of the charge pump frequency can be activated to reduce the peak emission.

The modulation frequency is set by the control bit FMODE in **GENCTRL**:

- FMODE = 0: No modulation.
- FMODE = 1: Modulation frequency = 15.6 kHz (default).

Gate Drivers

12.9 Electrical characteristics gate driver

The electrical characteristics related to the gate driver are valid for $V_{CP} > V_S + 8.5 V$

Table 33 Electrical characteristics: gate drivers

$V_{SINT} = 5.5 V$ to $28 V$, $T_j = -40^\circ C$ to $+150^\circ C$,

$V_{CP} > V_S + 8.5 V$, $V_S = 6$ to $19V$, all voltages with respect to ground, positive current flowing into pin except for I_{GLx} and I_{GHx} (unless otherwise specified).

Parameter	Symbol	Values			Unit	Note or Test Condition	Number
		Min.	Typ.	Max.			
Comparators							
SHx High Threshold	V_{SHH}	$V_S - 2.6$	-	$V_S - 1.9$	V		P_12.11.1
SHx Low Threshold	V_{SHL}	1.9	-	2.6	V	Referred to GND	P_12.11.2
SHx comparator delay	t_{SHx}	-	12	30	ns	1)	P_12.11.3
MOSFET Driver Output							
High Level Output Voltage GHx vs. SHx and GLx vs. SL	V_{GH1}	10	11.5	12.5	V	2) $V_S \geq 8 V$, $C_{Load} = 10 nF$, $I_{CP} = -12 mA$, FET_LVL = 1	P_12.11.4
High Level Output Voltage GHx vs. SHx and GLx vs. SL	V_{GH2}	7	-	12.5	V	$V_S = 6 V$, $C_{Load} = 10 nF$, $I_{CP} = -6 mA$, FET_LVL = 1	P_12.11.5
High Level Output Voltage GLx vs. SL	V_{GH3}	10	-	12.5	V	3) $V_S \geq 6 V$, $C_{Load} = 10 nF$, FET_LVL = 0	P_12.11.6
High Level Output Voltage GHx vs. SHx	V_{GH4}	8.5	10	12.5	V	2) $V_S \geq 8 V$, $C_{Load} = 10 nF$, $I_{CP} = -12 mA$, FET_LVL = 0	P_12.11.7
High Level Output Voltage GHx vs. SHx	V_{GH5}	7	-	12.5	V	$V_S = 6 V$, $C_{LOAD} = 10 nF$, $I_{CP} = -6 mA$, FET_LVL = 0	P_12.11.8
Charge current	I_{CHG0}	-60%	0.5	+60%	mA	$I_{CHG} = 0_D$ 1) $C_{Load} = 2.2 nF$ $V_S \geq 8V, V_{GS} \leq V_{GS(ON)}$ 4)	P_12.11.10
Charge current	I_{CHG8}	-55%	3.1	+55%	mA	$I_{CHG} = 8_D$ 1) $C_{Load} = 2.2 nF$ $V_S \geq 8V, V_{GS} \leq V_{GS(ON)}$ 4)	P_12.11.11
Charge current	I_{CHG16}	-40%	9.2	+40%	mA	$I_{CHG} = 16_D$ 1) $C_{Load} = 2.2 nF$ $V_S \geq 8V, V_{GS} \leq V_{GS(ON)}$ 4)	P_12.11.12
Charge current	I_{CHG32}	-30%	32.8	+30%	mA	$I_{CHG} = 32_D$ 1) $C_{Load} = 10 nF$ $V_S \geq 8V, V_{GS} \leq V_{GS(ON)}$ 4)	P_12.11.13

Gate Drivers

Table 33 Electrical characteristics: gate drivers (cont'd)

$V_{SINT} = 5.5\text{ V to }28\text{ V}$, $T_j = -40^\circ\text{C to }+150^\circ\text{C}$,
 $V_{CP} > V_S + 8.5\text{ V}$, $V_S = 6\text{ to }19\text{ V}$, all voltages with respect to ground, positive current flowing into pin except for I_{GLX}
and I_{GHX} (unless otherwise specified).

Parameter	Symbol	Values			Unit	Note or Test Condition	Number
		Min.	Typ.	Max.			
Charge current	I_{CHG48}	-30%	64.3	+30%	mA	$ICHG = 48_D^{1)}$ $C_{Load} = 10\text{ nF}$ $V_S \geq 8\text{ V}, V_{GS} \leq V_{GS(ON)}^{4)}$	P_12.11.14
Charge current	I_{CHG63}	-30%	100	+30%	mA	$ICHG = 63_D^{1)}$ $C_{Load} = 10\text{ nF}$ $V_S \geq 8\text{ V}, V_{GS} \leq V_{GS(ON)}^{4)}$	P_12.11.15
Discharge current	I_{DCH0}	-60 %	-0.5	+60%	mA	$IDCHG = 0_D^{1)}$ $C_{Load} = 2.2\text{ nF}$ $V_S \geq 8\text{ V}, V_{GS} \geq V_{GS(OFF1)}$	P_12.11.16
Discharge current	I_{DCH8}	-55 %	-3.1	+55%	mA	$IDCHG = 8_D^{1)}$ $C_{Load} = 2.2\text{ nF}$ $V_S \geq 8\text{ V}, V_{GS} \geq V_{GS(OFF1)}$	P_12.11.17
Discharge current	I_{DCHG16}	-40%	-9.2	+40%	mA	$IDCHG = 16_D^{1)}$ $C_{Load} = 2.2\text{ nF}$ $V_S \geq 8\text{ V}, V_{GS} \geq V_{GS(OFF1)}$	P_12.11.18
Discharge current	I_{DCHG32}	-30%	-32.2	+30%	mA	$IDCHG = 32_D^{1)}$ $C_{Load} = 10\text{ nF}$ $V_S \geq 8\text{ V}, V_{GS} \geq V_{GS(OFF2)}$	P_12.11.19
Discharge current	I_{DCHG48}	-30%	-63.2	+30%	mA	$IDCHG = 48_D^{1)}$ $C_{Load} = 10\text{ nF}$ $V_S \geq 8\text{ V}, V_{GS} \geq V_{GS(OFF2)}$	P_12.11.20
Discharge current	I_{DCHG63}	-30%	-100	+30%	mA	$IDCHG = 63_D^{1)}$ $C_{Load} = 10\text{ nF}$ $V_S \geq 8\text{ V}, V_{GS} \geq V_{GS(OFF2)}$	P_12.11.21
Charge current temperature drift	$I_{CHG0,TDrift}$	-37%	-12%	15%		$ICHG = 0_D^{1)5)}$	P_12.11.107
Charge current temperature drift	$I_{CHG8,TDrift}$	-17%	1%	20%		$ICHG = 8_D^{1)5)}$	P_12.11.108
Charge current temperature drift	$I_{CHG16,TDrift}$	-12%	3%	18%		$ICHG = 16_D^{1)5)}$	P_12.11.109
Charge current temperature drift	$I_{CHG32,TDrift}$	-11%	-1%	9%		$ICHG = 32_D^{1)5)}$	P_12.11.110
Charge current temperature drift	$I_{CHG48,TDrift}$	-7.5%	0.5%	8%		$ICHG = 48_D^{1)5)}$	P_12.11.111
Charge current temperature drift	$I_{CHG63,TDrift}$	-5.5%	1.5%	8.5%		$ICHG = 63_D^{1)5)}$	P_12.11.112
Discharge current temperature drift	$I_{DCHG0,TDrift}$	-29%	-4.5%	20%		$IDCHG = 0_D^{1)6)}$	P_12.11.113

Gate Drivers

Table 33 Electrical characteristics: gate drivers (cont'd)

$V_{SINT} = 5.5\text{ V to } 28\text{ V}$, $T_j = -40^\circ\text{C to } +150^\circ\text{C}$,
 $V_{CP} > V_S + 8.5\text{ V}$, $V_S = 6\text{ to } 19\text{V}$, all voltages with respect to ground, positive current flowing into pin except for I_{GLx}
and I_{GHx} (unless otherwise specified).

Parameter	Symbol	Values			Unit	Note or Test Condition	Number
		Min.	Typ.	Max.			
Discharge current temperature drift	$I_{DCHG8,TDrift}$	-8%	8.5%	26%		IDCHG = $8_D^{1)6)}$	P_12.11.114
Discharge current temperature drift	$I_{DCHG16,TDrift}$	-4%	9.5%	23%		IDCHG = $16_D^{1)6)}$	P_12.11.115
Discharge current temperature drift	$I_{DCHG32,TDrift}$	-4%	4.5%	13%		IDCHG = $32_D^{1)6)}$	P_12.11.116
Discharge current temperature drift	$I_{DCHG48,TDrift}$	-4%	3.5%	10%		IDCHG = $48_D^{1)6)}$	P_12.11.117
Discharge current temperature drift	$I_{DCHG63,TDrift}$	-3.5%	3.5%	9.5%		IDCHG = $63_D^{1)6)}$	P_12.11.118
Charge current V_S drift	$I_{CHG0,VsDrift}$	3%	4.5%	6%		ICHG = $0_D^{1)7)}$	P_12.11.143
Charge current V_S drift	$I_{CHG8,VsDrift}$	4.5%	6%	7.5%		ICHG = $8_D^{1)7)}$	P_12.11.144
Charge current V_S drift	$I_{CHG16,VsDrift}$	4%	5.8%	7.5%		ICHG = $16_D^{1)7)}$	P_12.11.145
Charge current V_S drift	$I_{CHG32,VsDrift}$	2%	3.8	5.8%		ICHG = $32_D^{1)7)}$	P_12.11.146
Charge current V_S drift	$I_{CHG48,VsDrift}$	-0.5%	2%	4.5%		ICHG = $48_D^{1)7)}$	P_12.11.147
Charge current V_S drift	$I_{CHG63,VsDrift}$	-2.3%	0.3	2.8%		ICHG = $63_D^{1)7)}$	P_12.11.148
Discharge current V_S drift	$I_{DCHG0,VsDrift}$	-3%	-1.5%	0%		IDCHG = $0_D^{1)8)}$	P_12.11.149
Discharge current V_S drift	$I_{DCHG8,VsDrift}$	-3%	-0.5%	2%		IDCHG = $8_D^{1)8)}$	P_12.11.150
Discharge current V_S drift	$I_{DCHG16,VsDrift}$	-3.3%	-0.3%	2.3%		IDCHG = $16_D^{1)8)}$	P_12.11.151
Discharge current V_S drift	$I_{DCHG32,VsDrift}$	-2%	0%	2%		IDCHG = $32_D^{1)8)}$	P_12.11.152
Discharge current V_S drift	$I_{DCHG48,VsDrift}$	-1.5%	0%	1.5%		IDCHG = $48_D^{1)8)}$	P_12.11.153
Discharge current V_S drift	$I_{DCHG63,VsDrift}$	-1.5%	0.2%	1.5%		IDCHG = $63_D^{1)8)}$	P_12.11.154
Passive discharge resistance between GHx/GLx and GND	R_{GGND}	10	20	30	k Ω	¹⁾	P_12.11.22
Resistor between SHx and GND	R_{SHGND}	10	20	30	k Ω	¹⁾⁹⁾	P_12.11.23
Low RDSON mode	R_{ONCCP}	-	22	35	Ω	¹⁾ $V_S = 13.5\text{ V}$ $V_{CP} = V_S + 14\text{ V}$ $I_{CHG} = I_{DCHG} = 63_D$	P_12.11.24

Gate Drivers Dynamic Parameters

Gate Driver turn-on delay Time	t_{DGDRV_ON1}	-	-	400	ns	¹⁰⁾ From PWM ¹¹⁾ rising edge to 20% of I_{CHGx} , $x = 0\text{ to } 63$, $C_{Load} = 10\text{ nF}$, BDFREQ = 0	P_12.11.25
--------------------------------	------------------	---	---	-----	----	--	------------

Gate Drivers

Table 33 Electrical characteristics: gate drivers (cont'd)

$V_{SINT} = 5.5\text{ V to }28\text{ V}$, $T_j = -40^\circ\text{C to }+150^\circ\text{C}$,
 $V_{CP} > V_S + 8.5\text{ V}$, $V_S = 6\text{ to }19\text{ V}$, all voltages with respect to ground, positive current flowing into pin except for I_{GLX}
and I_{GHX} (unless otherwise specified).

Parameter	Symbol	Values			Unit	Note or Test Condition	Number
		Min.	Typ.	Max.			
Gate Driver turn-on delay Time	t_{DGDRV_ON2}	–	–	300	ns	¹⁰⁾ From PWM ¹¹⁾ rising edge to 20% of I_{CHGx} , $x = 0\text{ to }63$, $C_{Load} = 10\text{ nF}$, BDFREQ = 1	P_12.11.93
Gate Driver current turn-on rise time	$t_{GDRV_RISE(ON)}$	–	30	50	ns	¹⁰⁾ From 20% of I_{CHGx} to I_{CHGx} , $x = 0\text{ to }63$, $C_{Load} = 10\text{ nF}$	P_12.11.26
Gate Driver turn-off delay Time	t_{DGDRV_OFF1}	–	–	400	ns	¹⁰⁾ From PWM ¹¹⁾ rising edge to 20% of I_{DCHGx} , $x = 0\text{ to }63$, $C_{Load} = 10\text{ nF}$, BDFREQ = 0	P_12.11.27
Gate Driver turn-off delay Time	t_{DGDRV_OFF2}	–	–	300	ns	¹⁰⁾ From PWM ¹¹⁾ rising edge to 20% of I_{DCHGx} , $x = 0\text{ to }63$, $C_{Load} = 10\text{ nF}$, BDFREQ = 1	P_12.11.94
Gate Driver current turn-off rise time	$t_{GDRV_RISE(OFF)}$	–	30	50	ns	¹⁰⁾ From 20% of I_{DCHGx} to I_{DCHGx} , $x = 0\text{ to }63$, $C_{Load} = 10\text{ nF}$	P_12.11.28
External MOSFET gate-to-source voltage - ON	$V_{GS(ON)1}$	7	–	–	V	¹⁾ $V_S \geq 8\text{ V}$, FET_LVL =1	P_12.11.29
External MOSFET gate-to-source voltage - ON	$V_{GS(ON)2}$	5.5	–	–	V	¹⁾ $V_S \geq 8\text{ V}$, FET_LVL =0	P_12.11.100
External MOSFET gate-to-source voltage - OFF	$V_{GS(OFF)1}$	–	–	1.5	V	¹⁾ $IDCHGx \leq 36_D (\leq 40\text{ mA typ.})$	P_12.11.30
External MOSFET gate-to-source voltage - OFF	$V_{GS(OFF)2}$	–	–	3.8	V	¹⁾ $IDCHGx > 36_D (> 40\text{ mA typ.})$	P_12.11.101
PWM synchronization delay	t_{PWM_SYNCH0}	80	–	200	ns	¹⁾ BDFREQ = 0	P_12.11.33
PWM synchronization delay	t_{PWM_SYNCH1}	40	–	100	ns	¹⁾ BDFREQ = 1	P_12.11.82
Bridge driver frequency	$t_{BDFREQ0}$	16.8	18.75	20.7	MHz	¹⁾ BDFREQ = 0	P_12.11.83
Bridge driver frequency	$t_{BDFREQ1}$	33.7	37.5	42.3	MHz	¹⁾ BDFREQ = 1	P_12.11.84

Gate Drivers

Table 33 Electrical characteristics: gate drivers (cont'd)

$V_{SINT} = 5.5\text{ V to }28\text{ V}$, $T_j = -40^\circ\text{C to }+150^\circ\text{C}$,

$V_{CP} > V_S + 8.5\text{ V}$, $V_S = 6\text{ to }19\text{ V}$, all voltages with respect to ground, positive current flowing into pin except for I_{GLX} and I_{GHX} (unless otherwise specified).

Parameter	Symbol	Values			Unit	Note or Test Condition	Number
		Min.	Typ.	Max.			
Pre-charge time	$t_{PCHG000}$	80	107	140	ns	¹⁾ TPCHG = 000, BDFREQ = 0 or 1	P_12.11.34
Pre-charge time	$t_{PCHG001}$	130	160	190	ns	¹⁾ TPCHG = 001, BDFREQ = 0 or 1	P_12.11.35
Pre-charge time	$t_{PCHG010}$	170	214	260	ns	¹⁾ TPCHG = 010, BDFREQ = 0 or 1	P_12.11.36
Pre-charge time	$t_{PCHG011}$	210	267	330	ns	¹⁾ TPCHG = 011, BDFREQ = 0 or 1	P_12.11.37
Pre-charge time	$t_{PCHG100}$	250	320	390	ns	¹⁾ TPCHG = 100, BDFREQ = 0 or 1	P_12.11.85
Pre-charge time	$t_{PCHG101}$	420	533	630	ns	¹⁾ TPCHG = 101, BDFREQ = 0 or 1	P_12.11.86
Pre-charge time	$t_{PCHG110}$	600	747	900	ns	¹⁾ TPCHG = 110, BDFREQ = 0 or 1	P_12.11.87
Pre-charge time	$t_{PCHG111}$	840	1067	1260	ns	¹⁾ TPCHG = 111, BDFREQ = 0 or 1	P_12.11.88
Pre-discharge time	$t_{PDCHG000}$	80	107	140	ns	¹⁾ TPDCHG = 000, BDFREQ = 0 or 1	P_12.11.38
Pre-discharge time	$t_{PDCHG001}$	130	160	190	ns	¹⁾ TPDCHG = 001, BDFREQ = 0 or 1	P_12.11.39
Pre-discharge time	$t_{PDCHG010}$	170	214	260	ns	¹⁾ TPDCHG = 010, BDFREQ = 0 or 1	P_12.11.40
Pre-discharge time	$t_{PDCHG011}$	210	267	330	ns	¹⁾ TPDCHG = 011, BDFREQ = 0 or 1	P_12.11.41
Pre-discharge time	$t_{PDCHG100}$	250	320	390	ns	¹⁾ TPDCHG = 100, BDFREQ = 0 or 1	P_12.11.89
Pre-discharge time	$t_{PDCHG101}$	420	533	630	ns	¹⁾ TPDCHG = 101, BDFREQ = 0 or 1	P_12.11.90
Pre-discharge time	$t_{PDCHG110}$	600	747	900	ns	¹⁾ TPDCHG = 110, BDFREQ = 0 or 1	P_12.11.91
Pre-discharge time	$t_{PDCHG111}$	840	1067	1260	ns	¹⁾ TPDCHG = 111, BDFREQ = 0 or 1	P_12.11.92

Low-side gate driver, CP off - Slam mode, parking braking and VS overvoltage braking

LS turn-on time, CP off	t_{ON_BRAKE}	-	4.5	9	μs	$C_{LOAD} = 10\text{ nF}$ $V_{GLX-VSL} = 5\text{ V}$, $V_S > 8\text{ V}$ or $V_{SINT} > 8\text{ V}$	P_12.11.42
-------------------------	-----------------	---	-----	---	---------------	--	------------

Gate Drivers

Table 33 Electrical characteristics: gate drivers (cont'd)

$V_{SINT} = 5.5\text{ V to }28\text{ V}$, $T_j = -40^\circ\text{C to }+150^\circ\text{C}$,

$V_{CP} > V_S + 8.5\text{ V}$, $V_S = 6\text{ to }19\text{ V}$, all voltages with respect to ground, positive current flowing into pin except for I_{GLX} and I_{GHX} (unless otherwise specified).

Parameter	Symbol	Values			Unit	Note or Test Condition	Number
		Min.	Typ.	Max.			
LS turn-off time, CP off	t_{OFF_BRAKE}	–	0.7	2	μs	$C_{LOAD} = 10\text{ nF}$ $V_{GLX-VSL} = 1.5\text{ V}$, $V_S > 8\text{ V}$ or $V_{SINT} > 8\text{ V}$	P_12.11.43
High output voltage GLX - SL	V_{GLX_BRAKE}	5	–	10	V	$V_S > 8\text{ V}$ or $V_{SINT} > 8\text{ V}$	P_12.11.48

Charge pump

Charge Pump Frequency	f_{CP}	–	250	–	kHz	1)	P_12.11.49
Output Voltage VCP vs. VS	V_{CPmin1}	8.5	–	–	V	$V_S = 6\text{ V}$, $I_{CP} = -6\text{ mA}$, FET_LVL = 1	P_12.11.50
Output Voltage VCP vs. VS	V_{CPmin2}	7.5	–	–	V	$V_S = 6\text{ V}$, $I_{CP} = -6\text{ mA}$, FET_LVL = 0	P_12.11.51
Regulated CP output voltage, VCP vs. VS	V_{CP1}	12	15	17	V	$8\text{ V} < V_S < 23\text{ V}$ $I_{CP} = -12\text{ mA}^{13)}$, CPSTGA = 0, FET_LVL = 1	P_12.11.52
Regulated CP output voltage, VCP vs. VS	V_{CP2}	12	15	17	V	$18\text{ V} < V_S < 23\text{ V}$ $I_{CP} = -12\text{ mA}^{13)}$, CPSTGA = 1, FET_LVL = 1	P_12.11.53
Regulated CP output voltage, VCP vs. VS	V_{CP3}	7.5	11	13	V	$8\text{ V} < V_S < 23\text{ V}$ $I_{CP} = -12\text{ mA}^{13)}$, CPSTGA = 0, FET_LVL = 0	P_12.11.54
Regulated CP output voltage, VCP vs. VS	V_{CP4}	7.5	11	13	V	$13\text{ V} < V_S < 23\text{ V}$ $I_{CP} = -12\text{ mA}^{13)}$, CPSTGA = 0, FET_LVL = 0	P_12.11.55
Turn-on time	t_{ON_VCP1}	5	–	60	μs	1)12)13) $18\text{ V} < V_S < 23\text{ V}$ (25%), $I_{CP} = 0$, CPSTGA = 1, FET_LVL = 1	P_12.11.56
Rise time	t_{RISE_VCP1}	5	30	60	μs	1)12)13) $18\text{ V} < V_S < 23\text{ V}$ (25%-75%) $I_{CP} = 0$, CPSTGA = 1, FET_LVL = 1	P_12.11.57
Turn-on time	t_{ON_VCP2}	20	60	120	μs	1)12)13) $13\text{ V} < V_S < 23\text{ V}$ (25%), $I_{CP} = 0$, CPSTGA = 1, FET_LVL = 0	P_12.11.58

Gate Drivers

Table 33 Electrical characteristics: gate drivers (cont'd)

$V_{SINT} = 5.5\text{ V to } 28\text{ V}$, $T_j = -40^\circ\text{C to } +150^\circ\text{C}$,
 $V_{CP} > V_S + 8.5\text{ V}$, $V_S = 6\text{ to } 19\text{ V}$, all voltages with respect to ground, positive current flowing into pin except for I_{GLX} and I_{GHX} (unless otherwise specified).

Parameter	Symbol	Values			Unit	Note or Test Condition	Number
		Min.	Typ.	Max.			
Rise time	t_{RISE_VCP2}	5	30	60	μs	¹⁾²⁾¹³⁾ $13\text{ V} < V_S < 23\text{ V}$ (25%-75%) $I_{CP} = 0$, $CPSTGA = 1$, $FET_LVL = 0$	P_12.11.59
Automatic switch over dual to single stage charge pump	V_{CPSO_DS}	16	17	18	V	$CPSTGA = 1$, $FET_LVL = 1$, VS rising	P_12.11.60
Automatic switch over dual to single stage charge pump	V_{CPSO_DS}	11.5	12.25	13	V	$CPSTGA = 1$, $FET_LVL = 0$, VS rising	P_12.11.61
Automatic switch over single to dual stage charge pump	V_{CPSO_SD}	15.5	16.5	17.5	V	$CPSTGA = 1$, $FET_LVL = 1$, VS falling	P_12.11.62
Automatic switch over single to dual stage charge pump	V_{CPSO_SD}	11	11.75	12.5	V	$CPSTGA = 1$, $FET_LVL = 0$, VS falling	P_12.11.64
Charge pump switch over hysteresis	V_{CPSO_HY}	-	0.5	-	V	¹⁾ $CPSTGA = 1$ $V_{CPSO_DS} - V_{CPSO_SD}$	P_12.11.65
Charge pump minimum output current	I_{CPOC1}	-	-	-12	mA	¹³⁾ $8\text{ V} < V_S < 28\text{ V}$ $CPSTGA = 0$ $FET_LVL = 1$	P_12.11.68
Charge pump minimum output current	I_{CPOC2}	-	-	-12	mA	¹³⁾ $8\text{ V} < V_S < 28\text{ V}$ $CPSTGA = 0$ $FET_LVL = 0$	P_12.11.69

Digital PWMx Inputs

High Level Input Voltage Threshold	V_{PVMH}	-	-	$0.7 \times V_{CC1}$	V	-	P_12.11.95
Low Level Input Voltage Threshold	V_{PVML}	$0.3 \times V_{CC1}$	-	-	V	-	P_12.11.96
PWMx Input Hysteresis	$V_{PWM,hys}$	-	$0.12 \times V_{CC1}$	-	V	¹⁾	P_12.11.97
PWMx Pull-down Resistance	R_{PD_PWM}	20	40	80	k Ω	-	P_12.11.98

CRC Select; Pin PWM1/CRC

Config Pull-up Resistance	R_{CFG}		100		k Ω	¹⁴⁾	P_12.11.99
Config Select Filter Time	t_{CFG_F}	5	10	14	μs	¹⁾	P_12.11.105

1) Not subject to production test, specified by design.

2) Independent from **CPSTGA**.

3) $ICP = -12\text{ mA}$ for $VS \geq 8\text{ V}$, $ICP = 6\text{ mA}$ for $VS = 6\text{ V}$.

Gate Drivers

- 4) $V_{GS(ON)} = V_{GS(ON)1}$ if **FET_LVL** = 1, $V_{GS(ON)} = V_{GS(ON)2}$ if **FET_LVL** = 0.
- 5) $(ICHGx@Tj=150^{\circ}C - ICHGx@Tj=-40^{\circ}C) / ICHGx@Tj=25^{\circ}C$
- 6) $(IDCHGx@Tj=150^{\circ}C - IDCHGx@Tj=-40^{\circ}C) / IDCHGx@Tj=25^{\circ}C$
- 7) $(ICHGx@VS=19V - ICHGx@VS=8V) / ICHGx@VS=13.5V$
- 8) $(IDCHGx@VS=19V - IDCHGx@VS=8V) / IDCHGx@VS=13.5V$
- 9) This resistance is the resistance between GHx and GND connected through a diode to SHx. As a consequence, the voltage at SHx can rise up to 0.6 V typ. before it is discharged through the resistor.
- 10) Not subject to production test, specified by design.
- 11) External PWM signal.
- 12) Parameter dependent on the capacitance C_{CP} .
- 13) $C_{CPC1} = C_{CPC2} = 220$ nF, $C_{CP} = 470$ nF. Other C_{CP} values higher than 470 nF can be used. Note that this capacitor influences the charge pump rise and turn-on times, and the charge, V_{CP} ripple voltage when charging the gate of a MOSFET.
- 14) Config Pull-up will be only active during startup-phase for checking external pull-down. After checking, the typ. 40 k Ω Pull-down resistance will be present.

13 Supervision Functions

13.1 Reset Function

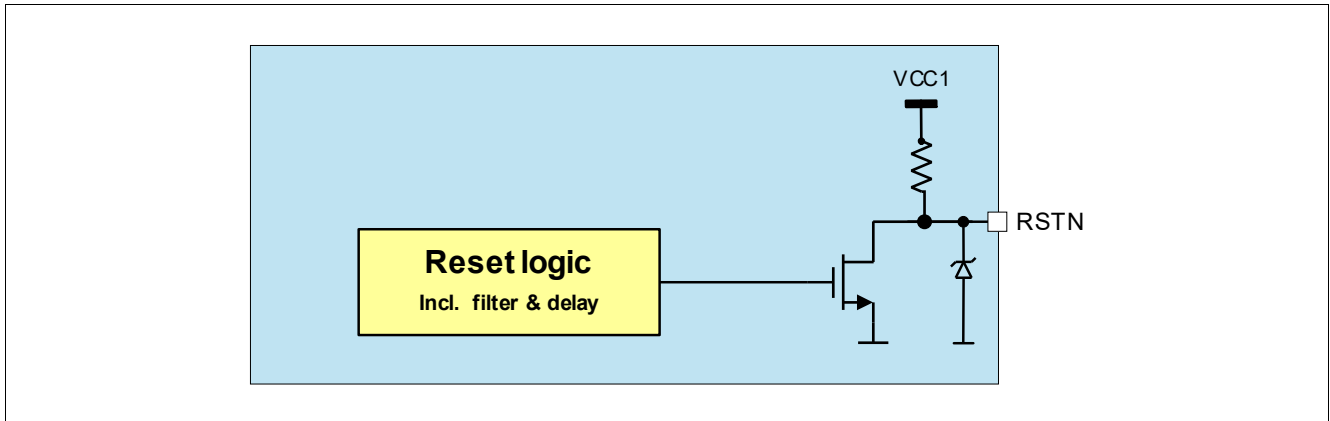

Figure 80 Reset Block Diagram

13.1.1 Reset Output Description

The reset output pin RSTN provides a reset information to the microcontroller, for example, in the event that the output voltage has fallen below the undervoltage threshold V_{RTX} . In case of a reset event, the reset output RSTN is pulled to low after the filter time t_{RF} and stays low as long as the reset event is present plus a reset delay time t_{RD1} or t_{RD2} depending on the value in **RSTN_DEL**. When connecting the device to battery voltage, the reset signal remains low initially. When the output voltage VCC1 has reached the reset default threshold $V_{RT1,r}$ the reset output RSTN is released to high after the reset delay time t_{RD1} . A reset can also occur due to a watchdog trigger failure. The reset threshold can be adjusted via SPI, the default reset threshold is $V_{RT1,f}$. The RSTN pin has an integrated pull-up resistor. In case reset is triggered, it will be pulled low for $VCC1 \geq 1V$ and for $VSINT \geq V_{POR,f}$ (see also [Chapter 13.3](#)).

The timings for the RSTN triggering regarding VCC1 undervoltage and watchdog trigger is shown in [Figure 81](#).

Supervision Functions

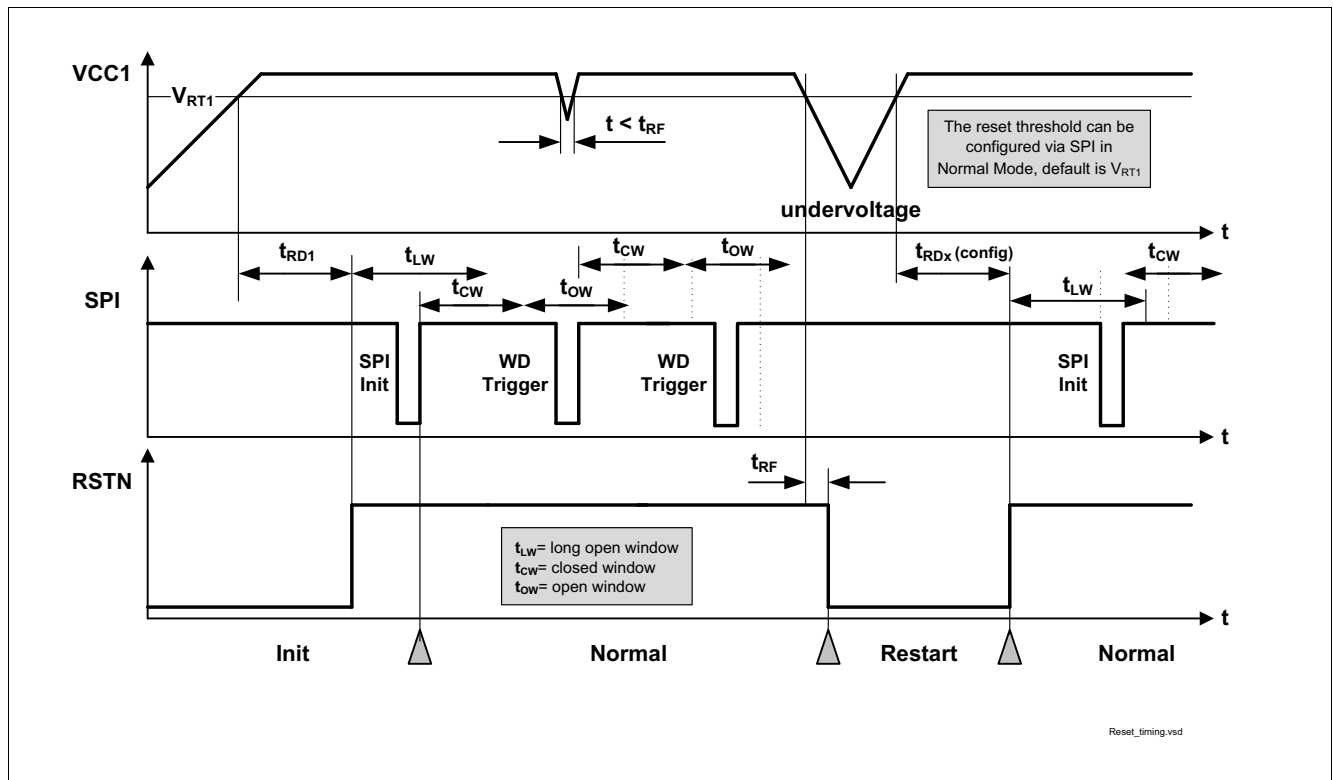

Figure 81 Reset Timing Diagram

13.1.2 Soft Reset Description

In Normal Mode and Stop Mode, it is also possible to trigger a device internal reset via a SPI command in order to bring the device into a defined state in case of failures. In this case the microcontroller must send a SPI command and set the **MODE** bits to '11' in the **M_S_CTRL** register. As soon as this command becomes valid, the device is set back to Init Mode and all SPI registers are set to their default values (see SPI [Chapter 14.5.1](#) and [Chapter 14.6.1](#)).

Two different soft reset configurations are possible via the SPI bit **SOFT_RESET_RO**:

- **SOFT_RESET_RO** = '0': The reset output (RSTN) is triggered when the soft reset is executed (default setting) The configured reset delay time **t_{RD1}** or **t_{RD2}** is applied depending on the value in **RSTN_DEL**.
- **SOFT_RESET_RO** = '1': The reset output (RSTN) is not triggered when the soft reset is executed.

Note: The device must be in Normal Mode or Stop Mode when sending this command. Otherwise, the command will be ignored.

Note: Allow CRC configuration after software-reset - or better check once again via SPI after software reset.

Supervision Functions

13.2 Watchdog Function

The watchdog is used to monitor the software execution of the microcontroller and to trigger a reset or move the device to Fail Safe Mode, if the microcontroller stops serving the watchdog due to a lock up in the software.

Two different types of watchdog functions are implemented and can be selected via the bit **WD_CFG**:

- Time-Out Watchdog (default value)
- Window Watchdog

The respective watchdog functions can be selected and programmed in Normal Mode. The configuration stays unchanged in Stop Mode.

Please refer to **Table 34** to match the device modes with the respective watchdog modes.

Table 34 Watchdog Functionality by modes

Mode	Watchdog Mode	Remarks
Init Mode	Starts with Long Open Window	Watchdog starts with Long Open Window after RSTN is released.
Normal Mode	WD Programmable	Window Watchdog, Time-Out watchdog or switched off for Stop Mode.
Stop Mode	Watchdog is fixed or off	
Sleep Mode	Off	Device will start with Long Open Window when entering Normal Mode.
Restart Mode	Off	Device will start with Long Open Window when entering Normal Mode.

The watchdog timing is programmed via SPI command in the register **WD_CTRL**. As soon as the watchdog is programmed, the timer starts with the new setting and the watchdog must be served. The watchdog is triggered by sending a valid SPI-write command to the watchdog configuration register. The watchdog trigger command is executed when the SPI command is interpreted.

When coming from Init Mode, Restart Mode or in certain cases from Stop Mode, the watchdog timer is always started with a long open window. The long open window (t_{LW}) allows the microcontroller to run its initialization sequences and then to trigger the watchdog via SPI.

The watchdog timer period can be selected via SPI (**WD_TIMER**).The timer setting is valid for both watchdog types.

The following watchdog timer periods are available:

- WD Setting 1: 10 ms
- WD Setting 2: 20 ms
- WD Setting 3: 50 ms
- WD Setting 4: 100 ms
- WD Setting 5: 200 ms
- WD Setting 6: 500 ms
- WD Setting 7: 1 s
- WD Setting 8: 10 s

In case of a reset, Restart Mode or Fail-Safe Mode is entered according to the configuration and the SPI bits **WD_FAIL** are set. Once the RSTN goes high again the watchdog immediately starts with a long open window the device enters automatically Normal Mode.

The Watchdog behaviour in Software Development Mode is described in **Chapter 5.4.7**.

Supervision Functions

In case a watchdog-trigger was missed in Software Development Mode, the watchdog will start with the long-open-window once again.

The **WD_FAIL** bits will be set after a watchdog trigger failure.

The **WD_FAIL** bits are cleared automatically when following conditions apply:

- After a successful watchdog trigger.
- When the watchdog is off: in Stop Mode after successfully disabling it, in Sleep Mode, or in Fail-Safe Mode (except for a watchdog failure).

13.2.1 Time-Out Watchdog

The time-out watchdog is an easier and less secure watchdog than a window watchdog as the watchdog trigger can be done at any time within the configured watchdog timer period.

A correct watchdog service immediately results in starting a new watchdog timer period. Taking the tolerances of the internal oscillator into account leads to the safe trigger area as defined in **Figure 82**.

If the time-out watchdog period elapses, a watchdog reset is created by setting the reset output RSTN low and the device switches to Restart Mode or Fail-Safe Mode.

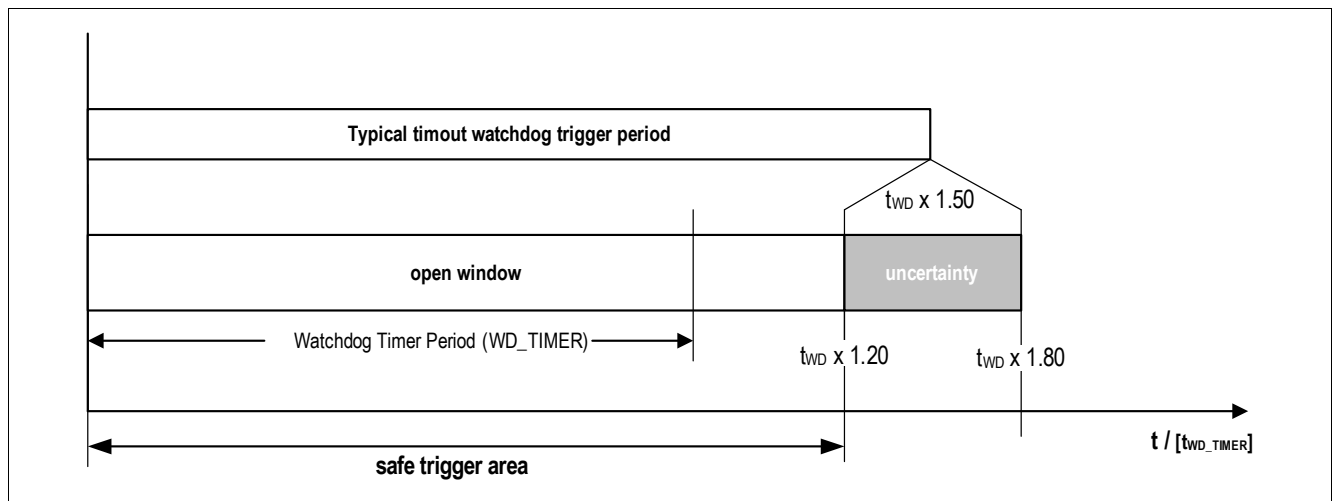

Figure 82 Time-out Watchdog Definitions

Supervision Functions

13.2.2 Window Watchdog

Compared to the time-out watchdog the characteristic of the window watchdog is that the watchdog timer period is divided between a closed and an open window. The watchdog must be triggered within the open window.

A correct watchdog trigger results in starting the window watchdog period by a closed window followed by an open window.

The watchdog timer period is at the same time the typical trigger time and defines the middle of the open window. Taking the oscillator tolerances into account leads to a safe trigger area of:

$$t_{WD} \times 0.72 < \text{safe trigger area} < t_{WD} \times 1.20.$$

The typical closed window is defined to a width of 60% of the selected window watchdog timer period. Taking the tolerances of the internal oscillator into account leads to the timings as defined in **Figure 83**.

A correct watchdog service immediately results in starting the next closed window.

If the trigger signal meet the closed window or if the watchdog timer period elapses, then a watchdog reset is triggered (RSTN low) and the device switches to Restart Mode or Fail-Safe Mode.

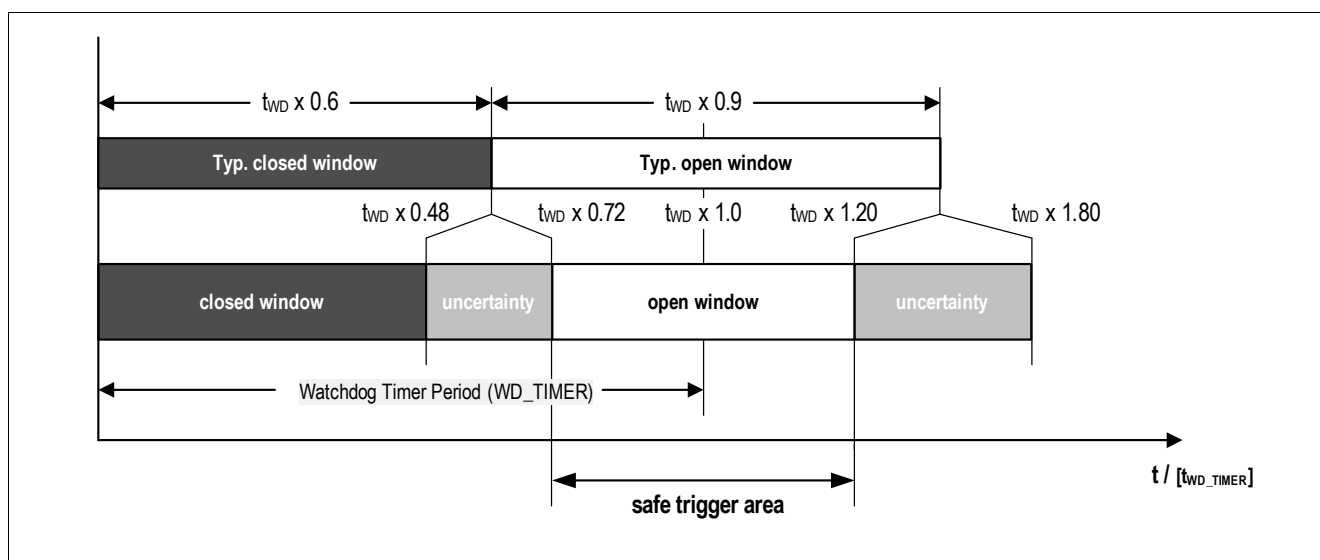

Figure 83 Window Watchdog Definitions

13.2.3 Watchdog Setting Check Sum

A check sum bit is part of the SPI command to trigger the watchdog and to set the watchdog setting.

The sum of the 16 data bits in the register **WD_CTRL** needs to have even parity (see **Equation (13.1)**). This is realized by either setting the bit **CHECKSUM** to 0 or 1. If the check sum is wrong, then the SPI command is ignored, i.e. the watchdog is not triggered or the settings are not changed and the bit **SPI_FAIL** is set.

The written value of the reserved bits of the **WD_CTRL** register is considered (even if read as '0' in the SPI output) for checksum calculation, i.e. if a 1 is written on the reserved bit position, then a 1 will be used in the checksum calculation.

(13.1)

$$\text{Bit}(\text{CHECKSUM}) = \text{Bit}22 \oplus \dots \oplus \text{Bit}8$$

13.2.4 Watchdog during Stop Mode

The watchdog can be disabled for Stop Mode in Normal Mode. For safety reasons, there is a special sequence to be followed in order to disable the watchdog as described in [Figure 84](#). Two different SPI bits ([WD_STM_EN_0](#), [WD_STM_EN_1](#)) in the registers [HW_CTRL](#) and [WD_CTRL](#) need to be set.

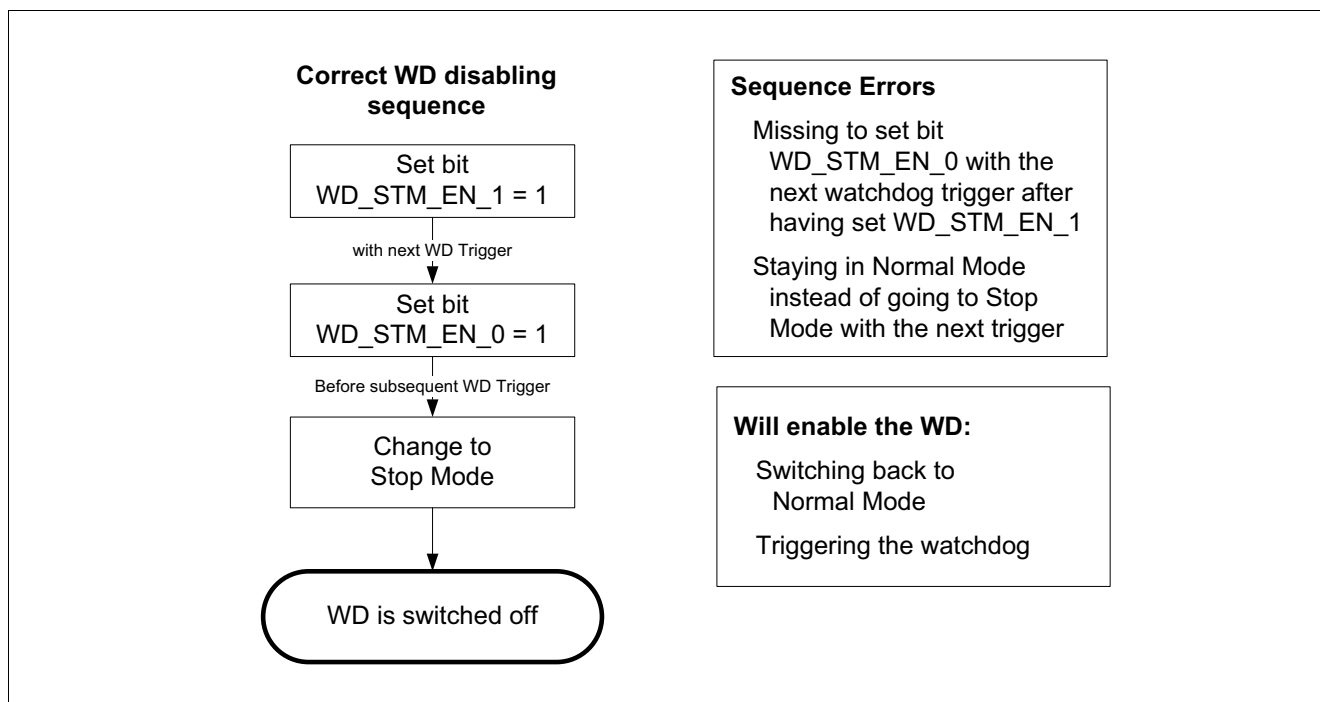

Figure 84 Watchdog disabling sequence in Stop Mode

If a sequence error occurs, then the bit [WD_STM_EN_1](#) will be cleared and the sequence has to be started again.

The watchdog can be enabled by triggering the watchdog in Stop Mode or by switching back to Normal Mode via SPI command. In both cases the watchdog will start with a long open window and the bits [WD_STM_EN_1](#) and [WD_STM_EN_0](#) are cleared. After the long open window the watchdog has to be served as configured in the [WD_CTRL](#) register.

Note: The bit [WD_STM_EN_0](#) will be cleared automatically when the sequence is started and it was 1 before. [WD_STM_EN_0](#) can also not be set if [WD_STM_EN_1](#) isn't yet set.

13.2.5 Watchdog Start in Stop Mode due to Bus Wake

In Stop Mode the Watchdog can be disabled. In addition a feature is available which will start the watchdog with any BUS wake (CAN, LIN) during Stop Mode. The feature is enabled by setting the bit [WD_EN_WK_BUS](#) = 1 (default value after POR). The bit can only be changed in Normal Mode and needs to be programmed before starting the watchdog disable sequence.

A wake on the Bus will generate an interrupt and the RXDCAN, RXDLIN is pulled to low. By these signals the microcontroller is informed that the watchdog is started with a long open window. After the long open window the watchdog has to be served as configured in the [WD_CTRL](#) register.

To disable the watchdog again, the device needs to be switched to Normal Mode and the sequence needs to be sent again.

Supervision Functions

13.3 VSINT Power On Reset

At power up of the device, the Power on Reset is detected when $VSINT > V_{POR,r}$ and the SPI bit **POR** is set to indicate that all SPI registers are set to POR default settings. VCC1 is starting up and the reset output will be kept low and will only be released once VCC1 has crossed $V_{RT1,r}$ and after t_{RD1} has elapsed.

In case $VSINT < V_{POR,f}$, an device internal reset will be generated and the device is switched off and will restart in Init Mode at the next VSINT rising. This is shown in **Figure 85**.

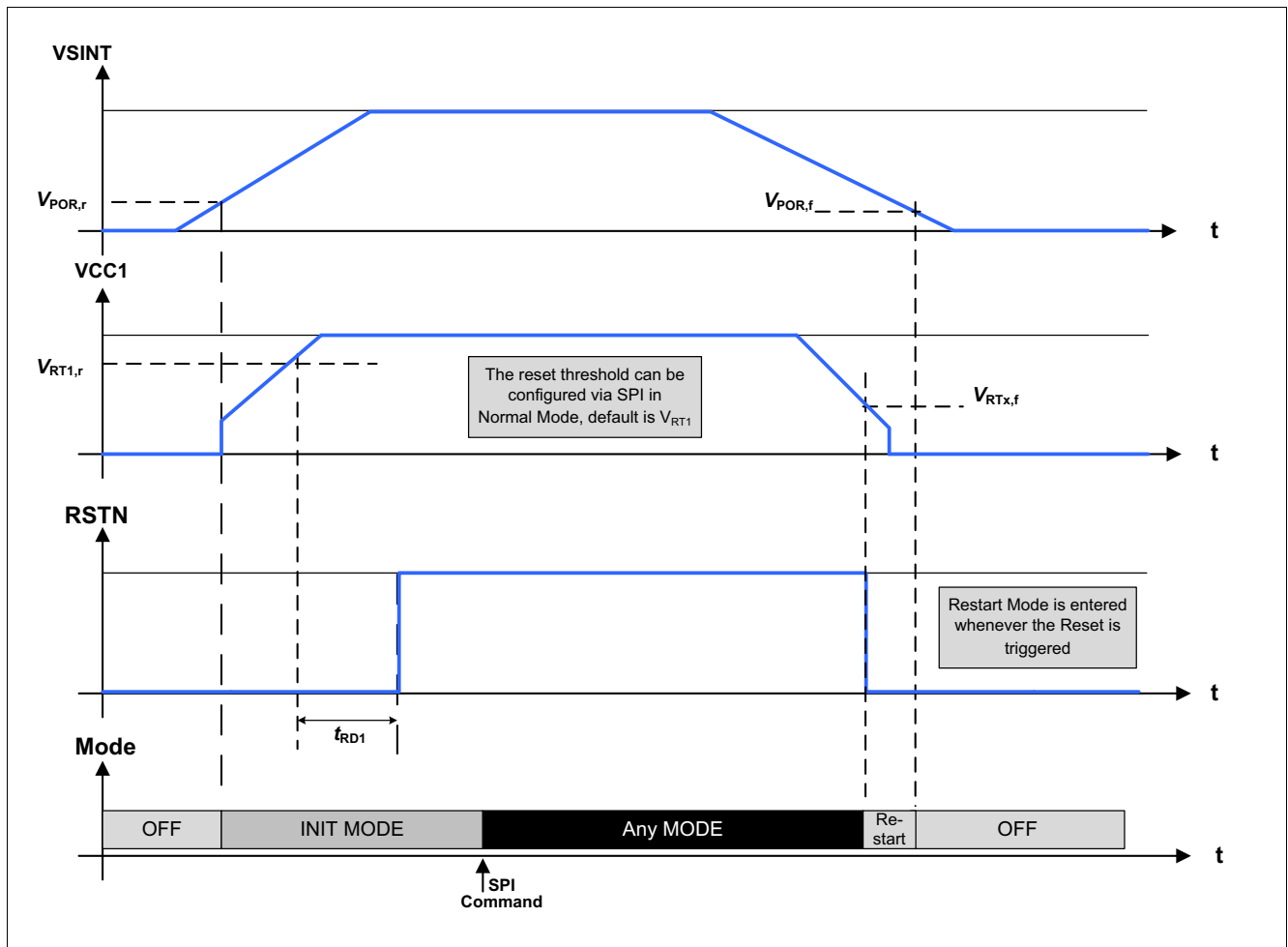

Figure 85 Ramp up / down example of Supply Voltage

13.4 VSINT Under- and Overvoltage

13.4.1 VSINT Undervoltage

The VSINT under-voltage monitoring is always active in Init Mode, Restart Mode, Normal Mode. If the supply voltage VSINT drops below $V_{SINT,UV}$ for more than t_{VSUV_FILT} , then the device does the following measures:

- The VCC1 short circuit diagnosis becomes inactive (see [Chapter 13.8](#)). However, the thermal protection of the device remains active. If the undervoltage threshold is exceeded (VSINT rising) then the function will be automatically enabled again.
- The status bit **VSINT_UV** is set and latched until a clear command of **SUP_STAT** is received.

Note: VSINT under-voltage monitoring is not available in Stop Mode due to current consumption saving requirements except if the VCC1 load current is above the active peak threshold (I_{PEAK_TH}) or if VCC1 is below the VCC1 prewarning threshold.

13.4.2 VSINT Overvoltage

The VSINT over-voltage monitoring is always active in Init Mode, Restart Mode and Normal Mode. If VSINT rises above $V_{S,OVD1}$, $V_{S,OVD2}$ for more than t_{VSOV_FILT} then the device does the following measures:

1. If HBxMODE = 01b or 10b, then the corresponding MOSFETs are actively turned off with their static discharge current during their respective tHBxCCP Active.
2. Then the charge pump is turned off and the passive discharge is activated.
3. The status bits **VSINT_OV** is set and latched until a clear command of **SUP_STAT** is received.

If VS or VSINT fall below $V_{S,OVD1}$ or $V_{S,OVD2}$:

- If **CPEN** = 0 : the charge pumps stays and the bridge driver stay off.
- If **CPEN** = 1 :
 - If **BDOV_REC** = 0 : Then the charge pump is reactivated but the bridge driver stays off until **VS_OV** and **VSINT_OV** are cleared.
 - If **BDOV_REC** = 1 : Then the charge pump is reactivated and the bridge driver is enabled if $V_{CP} > V_{CPUVx}$, even if **VS_OV** or **VSINT_OV** is set. The state of the external MOSFETs is according to the control registers.

13.5 VS Under- and Overvoltage

13.5.1 VS Undervoltage

The VS under-voltage monitoring is always active in Init-, Restart Mode and Normal Mode. If VS drops below $V_{S,UV}$ for more than t_{VSUV_FILT} , then the device does the following measures:

1. If HBxMODE = 01b or 10b, then the corresponding MOSFETs are actively turned off with their static discharge current during their respective tHBxCCP Active.
2. Then the charge pump is turned off and the passive discharge is activated.
3. The status bits **VS_UV** is set and latched until a clear command of **SUP_STAT** is received.

If VS rises above $V_{S,UV}$, then the charge pump is reactivated (provided that **CPEN** is set) but the bridge driver stays off until **VS_UV** is cleared. The bridge driver will be reactivated once the VS_UV bit is cleared.

13.5.2 VS Overvoltage

The VS over-voltage monitoring is always active in Init-, Restart Mode and Normal Mode or when the charge pump is enabled. If VS rises above $V_{S,OVD1}$ or $V_{S,OVD2}$ for more than t_{VSOV_FILT} , then the device does the following measures:

1. If HBxMODE = 01b or 10b, then the corresponding MOSFETs are actively turned off with their static discharge current during their respective tHBxCCP Active.
2. Then the charge pump is turned off and the passive discharge is activated.
3. The status bits **VS_OV** is set and latched until a clear command of **SUP_STAT** is received.

If VS and VSINT fall below $V_{S,OVD1}$ or $V_{S,OVD2}$:

- If **CPEN** = 0 : the charge pumps and the bridge driver stay off.
- If **CPEN** = 1 :
 - If **BDOV_REC** = 0 : Then the charge pump is reactivated (provided that **CPEN** = 1 and **CP_UV** = 0) but the bridge driver stays off until **VS_OV** and **VSINT_OV** are cleared.
 - If **BDOV_REC** = 1 : Then the charge pump is reactivated and the bridge driver is enabled if $V_{CP} > V_{CPUVx}$, even if **VS_OV** or **VSINT_OV** is set. The state of the external MOSFETs is according to the control registers.

13.6 VSHS Under- Overvoltage

13.6.1 VSHS Undervoltage

If the supply voltage VSHS passes below the undervoltage threshold ($V_{\text{SHS,UV}}$) the device does the following measures:

- HS1...4 are acting accordingly to the SPI setting (refer also to [Chapter 7.2.1](#)).
- LIN: Transmitter and Receiver are disabled during the VSHS undervoltage condition.
- SPI bit **HS_UV** is set. No other error bits are set. The bit can be cleared once the condition is not present anymore.

13.6.2 VSHS Overvoltage

If the supply voltage VSHS reaches the overvoltage threshold ($V_{\text{SHS,OVD}}$) the device triggers the following measures:

- HS1...4 are acting accordingly to the SPI setting (refer also to [Chapter 7.2.2](#)).
- The status bit **HS_OV** is set. No other error bits are set. The bit can be cleared once the condition is not present anymore.

13.7 VCC1 Over-/ Undervoltage and Undervoltage Prewarning

13.7.1 VCC1 Undervoltage and Undervoltage Prewarning

This function is always active when the VCC1 voltage regulator is enabled.

A first-level voltage detection threshold is implemented as a prewarning for the microcontroller. The prewarning event is signaled with the bit **VCC1_WARN**. No other actions are taken.

As described in [Chapter 13.1](#) and [Figure 86](#), a reset will be triggered (RSTN pulled low) when the V_{CC1} output voltage falls below the selected undervoltage threshold (V_{RTx}). The device will enter Restart Mode and the bit **VCC1_UV** is set when RSTN is released again.

The hysteresis of the VCC1 undervoltage threshold can be increased by setting the bit **RSTN_HYS**. In this case always the highest rising threshold ($V_{RT1,R}$) is used for the release of the undervoltage reset. The falling reset threshold remains as configured.

An additional safety mechanism is implemented to avoid repetitive VCC1 undervoltage resets due to high dynamic loads on VCC1:

- A counter is increased for every consecutive VCC1 undervoltage event (regardless on the selected reset threshold).
- The counter is active in Init Mode, Normal Mode and Stop Mode.
- For $V_S < V_{SINT,UV}$ the counter will be stopped in Normal Mode (i.e. the VS UV comparator is always enabled in Normal Mode).
- A 4th consecutive VCC1 undervoltage event will lead to Fail-Safe Mode entry and to setting the bit **VCC1_UV_FS**.
- This counter is cleared:
 - When Fail-Safe Mode is entered.
 - When the bit **VCC1_UV** is cleared.
 - When a Soft-Reset is triggered.

Note: After 4 consecutive **VCC1_UV** events, the device will enter Fail-Safe Mode and the **VCC1_UV_FS** bit is set.

Note: The **VCC1_WARN** or **VCC1_UV** bits are not set in Sleep Mode as $V_{CC1} = 0\text{ V}$ in this case.

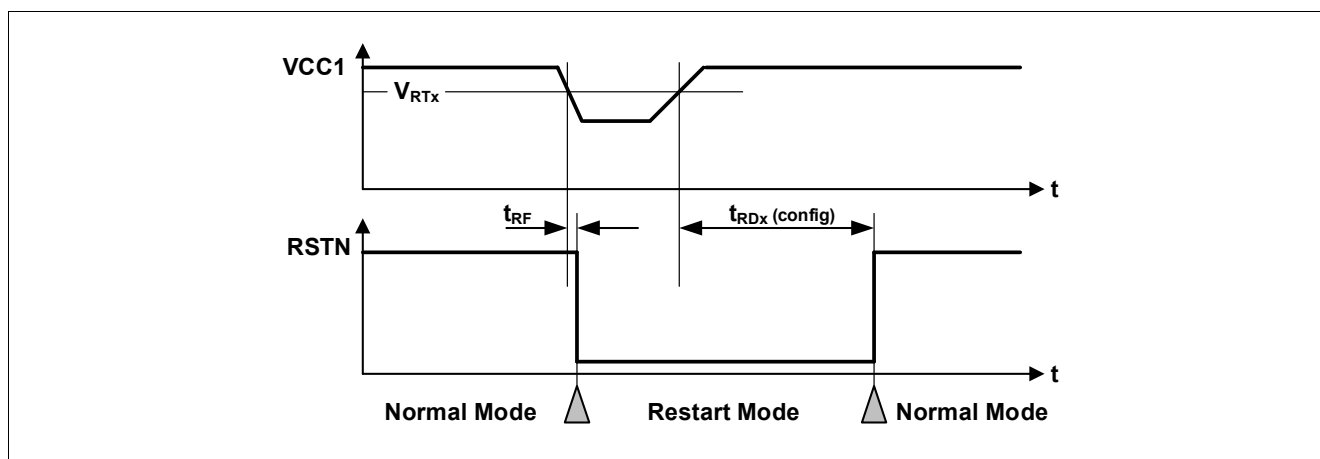

Figure 86 VCC1 Undervoltage Timing Diagram

Supervision Functions

Note: It is recommended to clear the **VCC1_WARN** and **VCC1_UV** bit once it is detected by the microcontroller software to verify if the undervoltage still exists or not.

13.7.2 VCC1 Overvoltage

For fail-safe reasons a configurable VCC1 over voltage detection feature is implemented. It is active when the VCC1 voltage regulator is enabled.

In case the $V_{CC1,OV,r}$ threshold is crossed, the device triggers following measures depending on the configuration:

- The bit **VCC1_OV** is always set.
- Based on the configuration of **VCC1_OV_MOD**, different kind of event are generated from device.
- If the **VCC1_OV_MOD**=11_B, in case of the device enters in Fail Safe Mode, the Fail Safe Output is activated (according **WK2_FO** setting).

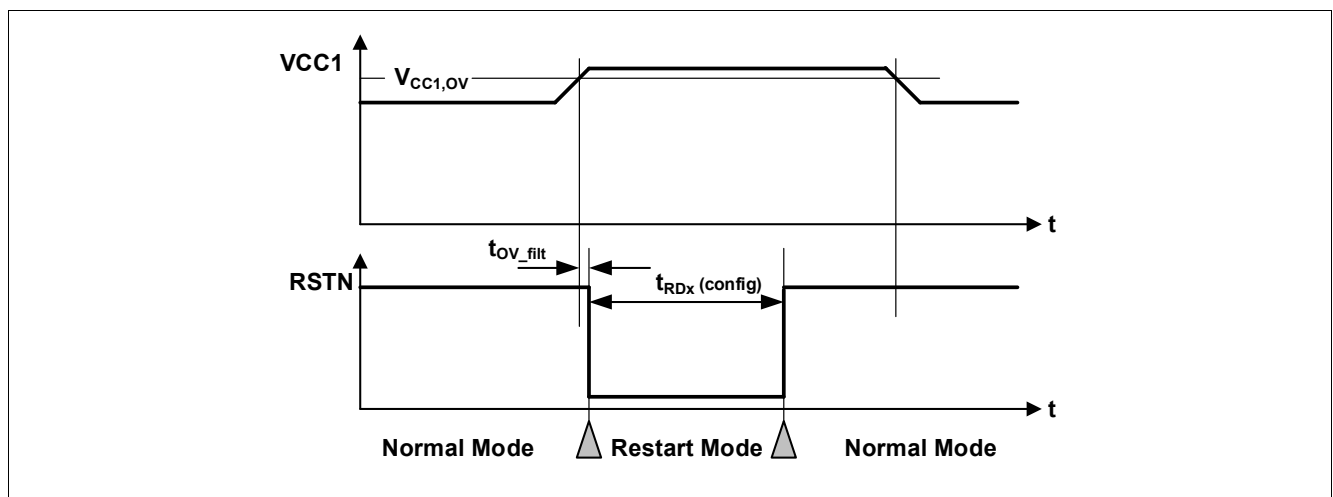

Figure 87 VCC1 Over Voltage Timing Diagram

13.8 VCC1 Short Circuit Diagnostics

The short circuit protection feature for V_{CC1} is implemented as follows:

- The short circuit detection is only enabled if $V_S > V_{SINT,UV}$.
- If VCC1 is not above the V_{RTX} within $t_{VCC1,SC}$ after device power up or after waking from Sleep Mode or Fail-Safe Mode (i.e. after VCC1 is enabled) then the SPI bit **VCC1_SC** bit is set, VCC1 is turned off, the FO pin is enabled, **FAILURE** is set and Fail-Safe Mode is entered. The device can be activated again via a wake-up sources.
- The same behavior applies, if V_{CC1} falls below V_{RTX} for longer than $t_{VCC1,SC}$.

13.9 VCAN Undervoltage

An undervoltage warning is implemented for VCAN as follows:

- V_{CAN} undervoltage detection: In case the CAN module is enabled and the voltage on V_{CAN} will drop below the $V_{CAN_UV,f}$ threshold, then the SPI bit **VCAN_UV** is set and can be only cleared via SPI.

Supervision Functions

13.10 Thermal Protection

Three independent and different thermal protection features are implemented in the device according to the system impact:

- Individual thermal shutdown of specific blocks
- Temperature prewarning of VCC1 voltage regulator
- Device thermal shutdown due to VCC1 overtemperature

13.10.1 Individual Thermal Shutdown

As a first-level protection measure, LIN, CAN, HSx and the charge pump are independently switched off if the respective block reaches the temperature threshold T_{JTSD1} . Then the **TSD1** bit is set. This bit can only be cleared via SPI once the overtemperature is not present anymore. Independent of the device mode the thermal shutdown protection is only active if the respective block is ON.

The respective modules behave as follows:

- CAN: The transmitter is disabled and stays in CAN Normal Mode acting like CAN Receive Only Mode. The status bits **CAN_FAIL** are set to '01'. Once the overtemperature condition is not present anymore, then the CAN transmitter is automatically switched on.
- LIN: The transmitter is disabled and stays in LIN Normal Mode acting like LIN Receive Only Mode. The status bits **LIN_FAIL** are set to '01'. Once the over temperature condition is not present anymore, then the LIN transmitter is automatically switched on.
- HSx: If one or more HSx switches reach the TSD1 threshold, then the HSx switches are turned OFF (depending on configuration either individually or all at once) and the control bits for HSx are cleared based on **HS_OT_SD_DIS** setting. The status bits HSx_OT are set (see register **HS_OL_OC_OT_STAT**). Once the over temperature condition is not present anymore, then HSx has to be configured again by SPI.
- Charge pump: If the charge pump reaches T_{JTSD1} , then **CP_OT** is set, **CPEN** is cleared and the activated MOSFETs are actively discharged with their respective static currents during their respective active cross current protection times (tHBxCCP active). When all tHBxCCP active elapsed, then the charge pump and the MOSFETs active discharge are disabled. Once the over temperature condition is not present anymore, then **CPEN** has to be configured again by SPI.

Note: The diagnosis bits are not cleared automatically and have to be cleared via SPI once the overtemperature condition is not present anymore.

13.10.2 Temperature Prewarning

As a next level of thermal protection a temperature prewarning is implemented if the main supply VCC1 reaches the thermal prewarning temperature threshold T_{JPW} . Then the status bit **TPW** is set. This bit can only be cleared via SPI once the overtemperature is not present anymore.

13.10.3 Thermal Shutdown

As a highest level of thermal protection a temperature shutdown of the device is implemented if the main supply VCC1 reaches the thermal shutdown temperature threshold T_{JTSD2} . Once a TSD2 event is detected Fail-Safe Mode is entered. Only when device temperature falls below the TSD2 threshold then the device remains in Fail-Safe Mode for t_{TSD2} to allow the device to cool down. After this time has expired, the device will automatically change via Restart Mode to Normal Mode (see also [Chapter 5.4.6](#)).

When a TSD2 event is detected, then the status bit **TSD2** is set. This bit can only be cleared via SPI in Normal Mode once the overtemperature is not present anymore.

Supervision Functions

For increased robustness requirements it is possible to extend the TSD2 waiting time by 64x of t_{TSD2} after 16 consecutive TSD2 events by setting the SPI bit **TSD2_DEL**. The counter is incremented with each TSD2 event even if the bit **TSD2** is not cleared. Once the counter has reached the value 16, then the bit **TSD2_SAFE** is set and the extended TSD2 waiting time is active. The extended waiting time will be kept until **TSD2_SAFE** is cleared. The TSD counter is cleared when **TSD2** or **TSD2_DEL** is cleared.

Note: In case a TSD2 overtemperature occurs while entering Sleep Mode then Fail-Safe Mode is still entered.

*Note: In case of a TSD2 event, the **FAILURE** bit is set to '1' and the **DEV_STAT** field is set to '01' inside the **DEV_STAT** register.*

Supervision Functions

13.11 Bridge driver

This section describes the supervision functions related to the bridge driver.

13.11.1 Bridge driver supervision with activated charge pump

This section describes the supervision functions when the charge pump is activated.

13.11.1.1 Drain-source voltage monitoring

Voltage comparators monitor the activated MOSFETs to protect high-side MOSFETs and low-side MOSFETs against a short circuit respectively to ground and to the battery during ON-state.

A drain-source overvoltage is detected on a low-side MOSFET if the voltage difference between VSHx and SL exceeds the threshold voltage configured by **LS_VDS** (see [Table 35](#)). Consequently, the corresponding half-bridge is latched off with the static discharge current.

A drain-source overvoltage is detected on a high-side MOSFET if the voltage difference between VS and VSHx exceeds the threshold voltage configured by **HS_VDS** (see [Table 36](#)). Consequently, the corresponding half-bridge is latched off with the static discharge current.

Table 35 Low-side drain-source overvoltage threshold

LSxVDSTH[2:0]	Drain-Source overvoltage threshold for LSx (typical)
000 _B	160 mV
001 _B	200 mV (default)
010 _B	300 mV
011 _B	400 mV
100 _B	500 mV
101 _B	600 mV
110 _B	800 mV
111 _B	2 V

Table 36 High-side drain-source overvoltage threshold

HSxVDSTH[2:0]	Drain-Source overvoltage threshold for HSx (typical)
000 _B	160 mV
001 _B	200 mV (default)
010 _B	300 mV
011 _B	400 mV
100 _B	500 mV
101 _B	600 mV
110 _B	800 mV
111 _B	2 V

Attention: 2 V threshold is dedicated for the diagnostic in off-state. It is highly recommended to select another drain-source overvoltage threshold once the routine of the diagnostic in off-state has been performed to avoid additional current consumption from VS and from the charge pump.

The device reports a Drain-Source overvoltage error if both conditions are met:

Supervision Functions

- After expiration of the blank time .
- If the Drain-Source voltage monitoring exceeds the configured threshold for a duration longer than the configured filter time (refer to [Table 37](#) and [LS_VDS](#) TFVDS bits).

Table 37 Drain-Source overvoltage filter time

TFVDS[2:0]	Drain-Source overvoltage filter time (typical)
00 _B	0.5 μs (default)
01 _B	1 μs
10 _B	2 μs
11 _B	6 μs

If a short circuit is detected by the Drain-Source voltage monitoring:

- The impacted half-bridge is latched off with the static discharge current for the configured cross-current protection time.
- The corresponding bit in the status register [DSOV](#) is set.
- The DSOV bit in Global Status Register [GEN_STAT](#) is set.

If a Drain-Source overvoltage is detected for one of the MOSFETs, then the status register [DSOV](#) must be cleared in order to re-enable the faulty half-bridge.

13.11.1.2 Cross-current protection and drain-source overvoltage blank time

All gate drivers feature a cross-current protection time and a Drain-Source overvoltage blank time.

The cross-current protection avoids the simultaneous activation of the high-side and the low-side MOSFETs of the same half-bridge.

During the blank time, the drain-source overvoltage detection is disabled, to avoid a wrong fault detection during the activation phase of a MOSFET.

Note: The setting of the cross-current protection and of the blank times may be changed by the microcontroller only if all [HBx_PWM_EN](#) bits are reset.

Note: Changing the Drain-Source overvoltage of a half-bridge *x* ([HBx](#)) in on-state ([HBxMODE\[1:0\]](#)=(0,1) or (1,0)) may result in a wrong VDS overvoltage detection on [HBx](#). Therefore it is highly recommended to change this threshold when [HBxMODE\[1:0\]](#)=(0,0) or (1,1)

13.11.1.2.1 Cross-current protection

The active and freewheeling cross-current protection times of each half-bridge is configured individually with the control register [CCP_BLK](#).

The typical cross-current protection time applied to the freewheeling MOSFET of the half-bridge *x* is 587 ns + 266 ns x [TCCP\[3:0\]_p](#), where [TCCP\[3:0\]_p](#) is the decimal value of the control bits [TCCP](#).

13.11.1.2.2 Drain-source overvoltage blank time

A configurable blank time for the Drain-Source monitoring is applied at the turn-on of the MOSFETs. During the blank time, a Drain-Source overvoltage error is masked.

Supervision Functions

For Half-Bridges in PWM mode with $AFW_x = 1$:

- the blank time of the PWM MOSFET starts at the expiration of the cross-current protection time of the PWM MOSFET. Refer to **Figure 88**.
- the blank time of the free-wheeling MOSFET starts after expiration of the cross-current protection time at turn-off of the PWM MOSFET. Refer to **Figure 88**.

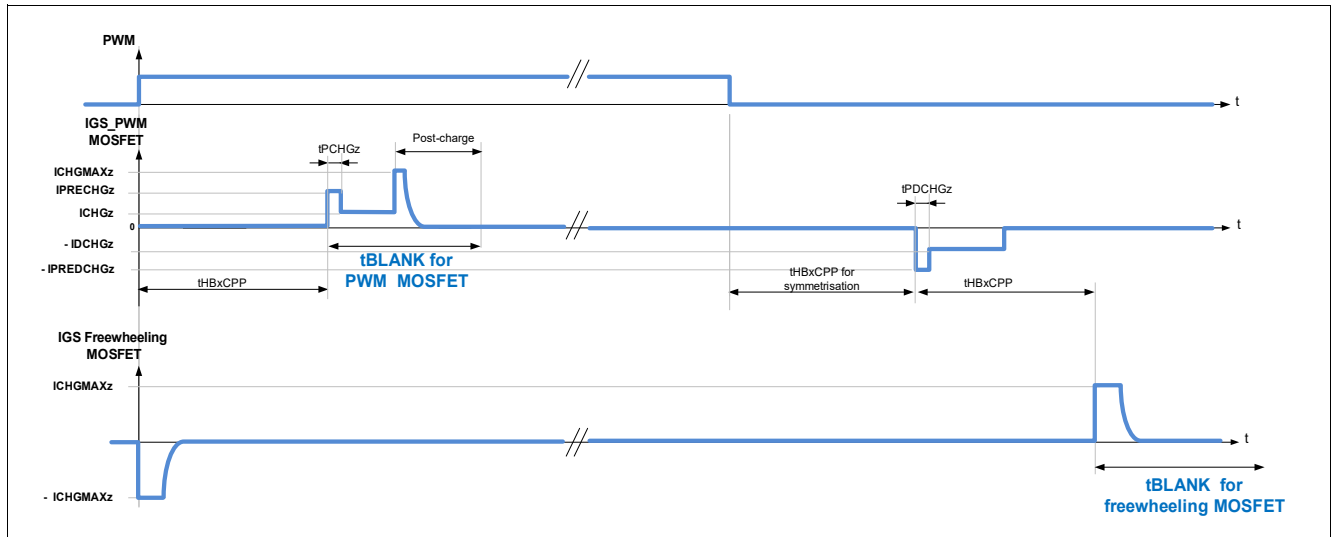

Figure 88 Blank time for half-bridges in PWM operation with $AFW = 1$

For statically activated half-bridges, the blank time starts:

- Case1: at expiration of the cross-current protection (**Figure 48**), if the opposite MOSFET was previously activated.
- Case 2: right after the decoding of the SPI command to turn on a MOSFET, if the half-bridge was in high impedance (**Figure 49**).

The blank times of the active and FW MOSFETs can be configured with the control register **CCP_BLK**.

The typical blank is $587 \text{ ns} + 266 \text{ ns} \times \text{TBLK}[3:0]_D$.

Note: The blank time is implemented at every new activation of a MOSFET, including a recovery from VS undervoltage, VS overvoltage, VSINT overvoltage, CP UV, CP OT.

13.11.1.3 OFF-state diagnostic

In order to support the off-state diagnostic ($HBxMODE = 11$ and $CPEN = 1$), the gate driver of each MOSFET provides pull-up (I_{PUDiag}) and a pull-down currents (I_{PDDiag}) at the SHx pins. This function requires an activated charge pump.

The pull-up current source of a given half-bridge is on when the half-bridge is active: $HBxMODE = 01, 10$ or 11 and $CPEN = 1$.

The pull-down current of each low-side gate driver is activated by the control bits HBx (**HB_ICHG_MAX** register).

During the off-state diagnostic routine performed by the microcontroller, the drain-source overvoltage threshold of the relevant half-bridges must be set to 2V nominal. Refer to **Table 35**. Once the routine is finished, it is highly recommended to decrease the drain-source overvoltage threshold to a lower value, avoiding additional current consumption from the VS input.

Supervision Functions

The following failures can be detected:

- MOSFET short circuit to GND
- MOSFET short circuit the battery
- Open load (disconnected motor)

The status of the output voltages VOUTx, can be read back with status bit HBxVOUT (register **GEN_STAT**) when the corresponding half-bridge is in off-state (HBxMODE[1:0] = 11).

Note: HBxVOUT = 0 if the half-bridge x is not actively off (HBxMODE[1:0] = (0,0), (0,1) or (1,0) and **CPEN**=1) or when the charge pump is deactivated (**CPEN**=0).

13.11.1.4 Charge pump undervoltage

The voltage of the charge pump output (VCP) is monitored in order to ensure a correct control of the external MOSFETs.

The charge pump undervoltage threshold is configurable by the control bits **FET_LVL** and **CPUVTH**.

Table 38 Charge pump undervoltage thresholds

	FET_LVL = 0	FET_LVL = 1
CPUVTH = 0	V_{CPUV1} (6 V typ. referred to VS)	V_{CPUV3} (7.5 V typ. referred to VS)
CPUVTH = 1	V_{CPUV2} (6.5 V typ. referred to VS)	V_{CPUV4} (8 V typ. referred to VS)

If VCP falls below the configured charge pump undervoltage threshold while **CPEN** = 1:

- If one of the MOSFET is on, then all MOSFETs are actively turned off with their configured static discharge current during their respective tHBxCCP active.
- Then the gate drivers are turned off .
- **CP_UV** is set and latched.

The **CP_UV** is reset and the normal operation is resumed once **SUP_STAT** is cleared and VCP > VCPUV.

The charge pump undervoltage detection is blanked (**t_{CPUVBLANK}**) during each new activation of the charge pump¹⁾.

13.11.1.5 Switching parameters of MOSFETs in PWM mode

The effective switching parameters of the active MOSFETs (**EN_GEN_CHECK**=1), respectively PWM MOSFET (**EN_GEN_CHECK**=0) can be read out with dedicated status registers:

- The turn-on and turn off delays, noted tDON and tDOFF are reported by the status register **EFF_TDON_OFF1**, **EFF_TDON_OFF2**, **EFF_TDON_OFF3**, **EFF_TDON_OFF4**.
- The rise and fall times, noted tRISE and tFALL, are reported by the status register **TRISE_FALL1**, **TRISE_FALL2**, **TRISE_FALL3**, **TRISE_FALL4**.

Refer to **Chapter 12.3** for the definition of tDON, tDOFF, tRISE and tFALL for high-side PWM and low-side PWM operations.

1) Including **CPEN** set to 1, recovery from VS under/overvoltage, VSINT overvoltage and CP_OT

Supervision Functions

13.11.2 Low-side drain-source voltage monitoring during braking

The low-side MOSFETs are turned-on while the charge pump is deactivated in the following conditions:

- The slam mode is activated and PWM1/CRC is High.
- The parking braking mode is activated and the device is in Sleep Mode or Stop Mode.
- VS overvoltage brake is activated and ($VS > VS$ Overvoltage braking or $VSINT > VSINT$ Overvoltage braking) in all device modes if **OV_BRK_EN** is set.

Under these conditions, the drain-source voltage of the low-sides are monitored and the applied drain-source overvoltage thresholds are according to **VDSTH_BRK**.

The applied blank time, which starts at the beginning of the brake activation, is:

- t_{BLK_BRAKE1} if **TBLK_BRK** = 0
- t_{BLK_BRAKE2} if **TBLK_BRK** = 1

During the blank time, a drain-source overvoltage of the low-sides is masked.

The applied filter time is t_{FVDS_BRAKE} .

If a drain-source overvoltage is detected during braking, then all low-side MOSFETs are turned off (latched) within t_{OFF_BRAKE} . SLAM_LSx_DIS (**BRAKE**, **SLAM**, **PARK_BRK_EN**, **OV_BRK_EN** are unchanged. The corresponding status bit LSxDSOV_BRK is set in **DSOV**.

The low-sides can be reactivated only if all LSxDSOV_BRK bits (**DSOV**) are cleared (even in slam mode with the respective LSx disabled by the SLAM_LSx_DIS bit).

If any of the status bits LSxDSOV_BRK is set, then the charge pump stays off (**CPEN**=1 command is accepted but the charge pump stays disabled until all LSxDSOV_BRK are cleared).

13.11.3 VS or VSINT Overvoltage braking

The VS and VSINT overvoltage braking is activated if the **OV_BRK_EN** bit in **BRAKE** register is set regardless of the device mode.

If VS, respectively VSINT, exceeds $V_{OVBR,cfgr,x}$ ($x = 0$ to 7), then all low-sides MOSFETs are turned-on within t_{ON_BRAKE} . The status bits **VSOVBRAKE_ST**, respectively **VSINTOVBRAKE_ST**, is set and latched (see **DSOV** register).

If VS and VSINT decrease below $V_{OVBR,cfgr,x} - V_{HYS,cfgr}$ ($x = 0$ to 7), then all low-sides MOSFETs are turned-off within t_{OFF_BRAKE} after the filter time $t_{OV_BR_FLT}$.

If $(VSHx - VSL)$ exceeds the configured threshold, then all low-sides MOSFETs are turned-off within t_{OFF_BRAKE} after the filter time t_{FVDS_BRAKE} . The threshold is:

- $V_{VDSMONTH0_BRAKE}$ if **VDSTH_BRK** = 0
- $V_{VDSMONTH1_BRAKE}$ if **VDSTH_BRK** = 1

Supervision Functions

13.12 Electrical Characteristics

Table 39 Electrical Characteristics

$V_{SINT} = 5.5 \text{ V to } 28 \text{ V}$; $T_j = -40^\circ\text{C to } +150^\circ\text{C}$; Normal Mode; all voltages with respect to ground; positive current defined flowing into pin; unless otherwise specified.

Parameter	Symbol	Values			Unit	Note or Test Condition	Number
		Min.	Typ.	Max.			
VCC1 Monitoring; VCC1 = 5.0V Version							
Undervoltage Prewarning Threshold Voltage PW,f	$V_{PW,f}$	4.53	4.70	4.84	V	VCC1 falling, SPI bit is set	P_13.12.1
Undervoltage Prewarning Threshold Voltage PW,r	$V_{PW,r}$	4.60	4.75	4.90	V	VCC1 rising	P_13.12.2
Undervoltage Prewarning Threshold Voltage hysteresis	$V_{PW,hys}$	30	50	90	mV	⁴⁾	P_13.12.3
VCC1 UV Prewarning Detection Filter Time	t_{VCC1,PW_F}	5	10	14	us	²⁾ rising and falling	P_13.12.4
Reset Threshold Voltage RT1,f	$V_{RT1,f}$	4.45	4.6	4.75	V	default setting; VCC1 falling	P_13.12.5
Reset Threshold Voltage RT1,r	$V_{RT1,r}$	4.58	4.74	4.90	V	default setting; VCC1 rising	P_13.12.6
Reset Threshold Voltage RT2,f	$V_{RT2,f}$	3.70	3.85	4.00	V	VCC1 falling	P_13.12.7
Reset Threshold Voltage RT2,r	$V_{RT2,r}$	3.85	4.0	4.15	V	VCC1 rising	P_13.12.8
Reset Threshold Voltage RT3,f	$V_{RT3,f}$	3.24	3.40	3.55	V	$V_S \geq 4 \text{ V}$; VCC1 falling	P_13.12.9
Reset Threshold Voltage RT3,r	$V_{RT3,r}$	3.39	3.54	3.70	V	$V_S \geq 4 \text{ V}$; VCC1 rising	P_13.12.10
Reset Threshold Voltage RT4,f	$V_{RT4,f}$	2.49	2.65	2.8	V	$V_S \geq 4 \text{ V}$; VCC1 falling	P_13.12.11
Reset Threshold Voltage RT4,r	$V_{RT4,r}$	2.65	2.76	2.95	V	$V_S \geq 4 \text{ V}$; VCC1 rising	P_13.12.12
Reset Threshold Hysteresis	$V_{RT,hys}$	70	140	220	mV	⁴⁾	P_13.12.13
VCC1 Over Voltage Detection Threshold Voltage	$V_{CC1,OV,r}$	5.5	5.65	5.8	V	¹⁾⁴⁾ rising VCC1	P_13.12.26
VCC1 Over Voltage Detection Threshold Voltage	$V_{CC1,OV,f}$	5.4	5.55	5.7	V	⁴⁾ falling VCC1	P_13.12.27
VCC1 OV Detection Filter Time	t_{VCC1,OV_F}	51	64	80	us	²⁾	P_13.12.31

Supervision Functions

Table 39 Electrical Characteristics (cont'd)

$V_{SINT} = 5.5\text{ V to }28\text{ V}$; $T_j = -40^\circ\text{C to }+150^\circ\text{C}$; Normal Mode; all voltages with respect to ground; positive current defined flowing into pin; unless otherwise specified.

Parameter	Symbol	Values			Unit	Note or Test Condition	Number
		Min.	Typ.	Max.			
VCC1 Short to GND Filter Time	$t_{VCC1,SC}$	3.2	4	4.8	ms	²⁾ blanking time during power-up, short circuit detection for $V_S \geq V_{S,UV}$	P_13.12.32

Reset Generator; Pin RSTN

Reset Low Output Voltage	$V_{RSTN,L}$	–	0.2	0.4	V	$I_{RSTN} = 1\text{ mA}$ for $V_{CC1} \geq 1\text{ V}$ & $V_S \geq V_{POR,f}$	P_13.12.33
Reset High Output Voltage	$V_{RSTN,H}$	$0.8 \times V_{CC1}$	–	$V_{CC1} + 0.3\text{ V}$	V	$I_{RSTN} = -20\text{ }\mu\text{A}$	P_13.12.34
Reset Pull-up Resistor	R_{RSTN}	10	20	40	k Ω	$V_{RSTN} = 0\text{ V}$	P_13.12.35
Reset Filter Time	t_{RF}	4	10	26	μs	²⁾ $V_{CC1} < V_{RT1x}$ to RSTN = L see also Chapter 13.3	P_13.12.36
Reset Delay Time 1	t_{RD1}	8	10	12	ms	²⁾ RSTN_DEL = 0	P_13.12.37
Reset Delay Time 2	t_{RD2}	1.6	2	2.4	ms	²⁾ RSTN_DEL = 1	P_13.12.64

VCAN Monitoring

CAN Supply undervoltage detection threshold (falling)	$V_{CAN,UV,f}$	4.5	–	4.75	V	VCAN falling	P_13.12.38
CAN Supply undervoltage detection threshold (rising)	$V_{CAN,UV,r}$	4.6	–	4.85	V	VCAN rising	P_13.12.39
V_{CAN} Undervoltage detection hysteresis	$V_{CAN,UV,hys}$	50	90	130	mV	⁴⁾	P_13.12.40
VCAN UV detection Filter Time	$t_{VCAN,UV,F}$	5	10	14	μs	²⁾ VCAN rising and falling	P_13.12.41

Watchdog Generator / Internal Oscillator

Long Open Window	t_{LW}	160	200	240	ms	²⁾	P_13.12.42
Internal Clock Generator Frequency	$f_{CLKSBC,1}$	0.8	1.0	1.2	MHz	–	P_13.12.43

Minimum Waiting time during Fail-Safe Mode

Min. waiting time Fail-Safe	$t_{FS,min}$	80	100	120	ms	²⁾³⁾	P_13.12.45
-----------------------------	--------------	----	-----	-----	----	-----------------	------------

Power-on Reset, Over / Undervoltage Protection

VSINT Power on reset rising	$V_{POR,r}$	–	–	4.5	V	VSINT increasing	P_13.12.46
VSINT Power on reset falling	$V_{POR,f}$	–	–	3	V	VSINT decreasing	P_13.12.47

Supervision Functions

Table 39 Electrical Characteristics (cont'd)

$V_{SINT} = 5.5 \text{ V to } 28 \text{ V}$; $T_j = -40^\circ\text{C to } +150^\circ\text{C}$; Normal Mode; all voltages with respect to ground; positive current defined flowing into pin; unless otherwise specified.

Parameter	Symbol	Values			Unit	Note or Test Condition	Number
		Min.	Typ.	Max.			
VSINT Undervoltage Detection Threshold	$V_{SINT,UV}$	5.3	–	6.0	V	Supply UV threshold for VCC1 SC detection; hysteresis included; includes rising and falling threshold	P_13.12.48
VSHS Overvoltage Detection Threshold	$V_{SHS,OVD}$	20	–	22	V	Supply OV supervision for HSx, LIN; hysteresis included	P_13.12.55
VSHS Overvoltage Detection hysteresis	$V_{SHS,OVD,hys}$	100	500	–	mV	⁴⁾	P_13.12.56
VSHS Undervoltage Detection Threshold	$V_{SHS,UVD}$	4.8	–	5.5	V	Supply UV supervision for HSx, LIN; hysteresis included	P_13.12.57
VSHS Undervoltage Detection hysteresis	$V_{SHS,UVD,hys}$	50	200	350	mV	⁴⁾	P_13.12.58
VSHS Undervoltage Detection Filter Time	$t_{VSHS,UV}$	5	10	14	us	²⁾ rising and falling	P_13.12.300
VSHS Overvoltage Detection Filter Time	$t_{VSHS,OV}$	5	10	14	us	²⁾ rising and falling	P_13.12.301

Charge Pump Undervoltage

Charge Pump Undervoltage Referred to VS	V_{CPUV1}	5.4	5.9	6.4	V	FET_LVL = 0 CPUVTH = 0 falling threshold, $VS \geq 6 \text{ V}$	P_13.12.59
Charge Pump Undervoltage Referred to VS	V_{CPUV2}	5.85	6.35	6.85	V	FET_LVL = 0 CPUVTH = 1 falling threshold, $VS \geq 6 \text{ V}$	P_13.12.60
Charge Pump Undervoltage Referred to VS	V_{CPUV3}	6.85	7.35	7.85	V	FET_LVL = 1 CPUVTH = 0 falling threshold, $VS \geq 6 \text{ V}$	P_13.12.61

Supervision Functions

Table 39 Electrical Characteristics (cont'd)

$V_{SINT} = 5.5 \text{ V to } 28 \text{ V}$; $T_j = -40^\circ\text{C to } +150^\circ\text{C}$; Normal Mode; all voltages with respect to ground; positive current defined flowing into pin; unless otherwise specified.

Parameter	Symbol	Values			Unit	Note or Test Condition	Number
		Min.	Typ.	Max.			
Charge Pump Undervoltage Referred to VS	V_{CPUV4}	7.5	8	8.5	V	FET_LVL = 1 CPUVTH = 1 falling threshold, $VS \geq 6 \text{ V}$	P_13.12.62
Charge Pump Undervoltage Filter Time	t_{CPUV}	51	64	80	μs	⁴⁾ $VS \geq 6 \text{ V}$	P_13.12.63
Charge Pump Undervoltage Blank Time	$t_{CPUVBLANK}$	400	500	600	μs	⁴⁾ $VS \geq 6 \text{ V}$	P_13.12.175

VS monitoring

VS undervoltage threshold	$V_{S,UV}$	4.7	–	5.4	V	hysteresis included	P_13.12.66
VS overvoltage threshold detection 1	$V_{S,OVD1}$	19	–	22.5	V	hysteresis included, VS_OV_SEL = 0	P_13.12.68
VS overvoltage threshold detection 2	$V_{S,OVD2}$	27.75	–	31.25	V	hysteresis included, VS_OV_SEL = 1	P_13.12.65
VS undervoltage filter time	t_{VSUV_FILT}	5	10	14	μs	²⁾ rising and falling	P_13.12.71
VS overvoltage filter time	t_{VSOV_FILT}	5	10	14	μs	²⁾ rising and falling	P_13.12.72

Off-state open load diagnosis

Pull-up diagnosis current	I_{PUDiag}	-600	-400	-270	μA	$VS \geq 6 \text{ V}$	P_13.12.73
Pull-down diagnosis current	I_{PDDiag}	1600	2200	2800	μA	$VS \geq 6 \text{ V}$	P_13.12.74
Diagnosis current ratio	I_{Diag_ratio}	4.25	5.25	6.25		Ratio I_{PDDiag} / I_{PUDiag}	P_13.12.302

Drain-source monitoring CP activated

Blank time	t_{BLANK}	typ-20%	587 +266 xTBLK	typ+20%	ns	⁴⁾ TBLK: decimal value of TBLK[3:0], $VS \geq 6 \text{ V}$	P_13.12.75
Cross-current protection time	t_{CCP}	typ-20%	587 +266 xTCCP	typ+20%	ns	⁴⁾ TCCP: decimal value of TCCPx[3:0], $VS \geq 6 \text{ V}$	P_13.12.76
HS/LS Drain-source overvoltage 0	$V_{VDSMONTH0_CPON}$	0.115	0.16	0.195	V	VDSTH[2:0] = 000 _B , $VS \geq 6 \text{ V}$, TFVDS=00 _B	P_13.12.77
HS/LS Drain-source overvoltage 1	$V_{VDSMONTH1_CPON}$	0.16	0.2	0.25	V	VDSTH[2:0] = 001 _B , $VS \geq 6 \text{ V}$, TFVDS=00 _B	P_13.12.78
HS/LS Drain-source overvoltage 2	$V_{VDSMONTH2_CPON}$	0.24	0.3	0.36	V	VDSTH[2:0] = 010 _B , $VS \geq 6 \text{ V}$, TFVDS=00 _B	P_13.12.79

Supervision Functions

Table 39 Electrical Characteristics (cont'd)

$V_{SINT} = 5.5\text{ V to }28\text{ V}$; $T_j = -40^\circ\text{C to }+150^\circ\text{C}$; Normal Mode; all voltages with respect to ground; positive current defined flowing into pin; unless otherwise specified.

Parameter	Symbol	Values			Unit	Note or Test Condition	Number
		Min.	Typ.	Max.			
HS/LS Drain-source overvoltage 3	$V_{VDSMONTH3_CPON}$	0.32	0.4	0.48	V	$VDSTH[2:0] = 011_B$, $VS \geq 6\text{ V}$, $TFVDS = 00_B$	P_13.12.80
HS/LS Drain-source overvoltage 4	$V_{VDSMONTH4_CPON}$	0.4	0.5	0.6	V	$VDSTH[2:0] = 100_B$, $VS \geq 6\text{ V}$, $TFVDS = 00_B$	P_13.12.81
HS/LS Drain-source overvoltage 5	$V_{VDSMONTH5_CPON}$	0.48	0.6	0.72	V	$VDSTH[2:0] = 101_B$, $VS \geq 6\text{ V}$, $TFVDS = 00_B$	P_13.12.82
HS/LS Drain-source overvoltage 6	$V_{VDSMONTH6_CPON}$	0.64	0.8	0.96	V	$VDSTH[2:0] = 110_B$, $VS \geq 6\text{ V}$, $TFVDS = 00_B$	P_13.12.83
HS/LS Drain-source overvoltage 7	$V_{VDSMONTH7_CPON}$	1.75	2.0	2.25	V	$VDSTH[2:0] = 111_B$, $VS \geq 6\text{ V}$, $TFVDS = 00_B$	P_13.12.84
Drain-Source monitoring - Slam mode, parking braking and VS overvoltage braking, VS or VSINT $\geq 8\text{ V}$							
Blank time	t_{BLK_BRAKE1}	4.5	7	9.5	μs	TBLK_BRK = 0, VS or $VSINT \geq 8\text{ V}$	P_13.12.85
Blank time	t_{BLK_BRAKE2}	9	11	13	μs	TBLK_BRK = 1, VS or $VSINT \geq 8\text{ V}$	P_13.12.86
VDS Filter time	t_{FVDS_BRAKE}	0.5	1	2.5	μs	VS or $VSINT \geq 8\text{ V}$	P_13.12.87
LS Drain-source monitoring thresholds	$V_{VDSMONTH0_BRAKE}$	0.56	0.8	1.05	V	VS or $VSINT \geq 8\text{ V}$ VDSTH_BRK = 0	P_13.12.89
LS Drain-source monitoring thresholds	$V_{VDSMONTH1_BRAKE}$	0.15	0.22	0.29	V	VS or $VSINT \geq 8\text{ V}$ VDSTH_BRK = 1	P_13.12.90
VS Overvoltage Braking Mode							
VS Overvoltage braking config 0 rising	$V_{OVBR, cfg0, r}$	25.65	27	28.35	V	OV_BRK_TH =000 _B	P_13.12.97
VS Overvoltage braking config 1 rising	$V_{OVBR, cfg1, r}$	26.60	28	29.40	V	OV_BRK_TH =001 _B	P_13.12.98
VS Overvoltage braking config 2 rising	$V_{OVBR, cfg2, r}$	27.55	29	30.45	V	OV_BRK_TH =010 _B	P_13.12.99
VS Overvoltage braking config 3 rising	$V_{OVBR, cfg3, r}$	28.50	30	31.50	V	OV_BRK_TH =011 _B	P_13.12.100
VS Overvoltage braking config 4 rising	$V_{OVBR, cfg4, r}$	29.45	31	32.55	V	OV_BRK_TH =100 _B	P_13.12.101
VS Overvoltage braking config 5 rising	$V_{OVBR, cfg5, r}$	30.40	32	33.60	V	OV_BRK_TH =101 _B	P_13.12.102
VS Overvoltage braking config 6 rising	$V_{OVBR, cfg6, r}$	31.35	33	34.65	V	OV_BRK_TH =110 _B	P_13.12.103
VS Overvoltage braking config 7 rising	$V_{OVBR, cfg7, r}$	32.30	34	35.70	V	OV_BRK_TH =111 _B	P_13.12.104
VS Overvoltage braking config 0	$V_{HYS, cfg0}$	0.64	0.75	0.85	V	OV_BRK_TH =000 _B	P_13.12.105

Supervision Functions

Table 39 Electrical Characteristics (cont'd)

$V_{SINT} = 5.5 \text{ V to } 28 \text{ V}$; $T_j = -40^\circ\text{C to } +150^\circ\text{C}$; Normal Mode; all voltages with respect to ground; positive current defined flowing into pin; unless otherwise specified.

Parameter	Symbol	Values			Unit	Note or Test Condition	Number
		Min.	Typ.	Max.			
VS Overvoltage braking config 1	$V_{HYS,cf1}$	0.74	0.82	0.9	V	OV_BRK_TH=001_B	P_13.12.109
VS Overvoltage braking config 2	$V_{HYS,cf2}$	0.80	0.89	0.98	V	OV_BRK_TH=010_B	P_13.12.113
VS Overvoltage braking config 3	$V_{HYS,cf3}$	0.85	0.95	1.05	V	OV_BRK_TH=011_B	P_13.12.117
VS Overvoltage braking config 4	$V_{HYS,cf4}$	0.93	1.03	1.13	V	OV_BRK_TH=100_B	P_13.12.121
VS Overvoltage braking config 5	$V_{HYS,cf5}$	0.97	1.08	1.19	V	OV_BRK_TH=101_B	P_13.12.125
VS Overvoltage braking config 6	$V_{HYS,cf6}$	1.03	1.15	1.27	V	OV_BRK_TH=110_B	P_13.12.129
VS Overvoltage braking config 7	$V_{HYS,cf7}$	1.1	1.23	1.36	V	OV_BRK_TH=111_B	P_13.12.133
VS and VSINT overvoltage braking filter time	$t_{OV_BR_FLT}$	10	15	20	μs	⁴⁾	P_13.12.200

Overtemperature Shutdown⁴⁾

Thermal Prewarning Temperature	T_{jPW}	125	145	165	$^\circ\text{C}$	T_j rising	P_13.12.169
Thermal Shutdown TSD1	T_{jTSD1}	170	185	200	$^\circ\text{C}$	T_j rising	P_13.12.170
Thermal Shutdown TSD2	T_{jTSD2}	170	185	200	$^\circ\text{C}$	T_j rising	P_13.12.171
Thermal Shutdown hysteresis	$T_{jTSD,hys}$	–	25	–	$^\circ\text{C}$	⁴⁾	P_13.12.172
TSD/TPW Filter Time	$t_{TSD_TPW_F}$	5	10	15	μs	rising and falling, applies to all thermal sensors (TPW, TSD1, TSD2)	P_13.12.173
Deactivation time after thermal shutdown TSD2	t_{TSD2}	0.8	1	1.2	s	²⁾	P_13.12.174

1) It is ensured that the threshold $V_{CC1,OV,r}$ is always higher than the highest regulated V_{CC1} output voltage $V_{CC1,out4}$.

2) Not subject to production test, tolerance defined by internal oscillator tolerance.

3) This time applies for all failure entries except a device thermal shutdown (TSD2 has a typ. 1 s waiting time t_{TSD2}).

4) Not subject to production test, specified by design.

Serial Peripheral Interface

14 Serial Peripheral Interface

The Serial Peripheral Interface is the communication link between the device and the microcontroller. The TLE9562-3QX is supporting multi-slave operation in full-duplex mode with 32-bit data access.

The SPI behavior for the different device modes is as follows:

- The SPI is enabled in Init Mode, Normal Mode and Stop Mode.
- The SPI is OFF in Sleep Mode, Restart Mode and Fail-Safe Mode.

14.1 SPI Block Description

The Control Input Word is read via the data input SDI, which is synchronized with the clock input CLK provided by the microcontroller. The output word appears synchronously at the data output SDO (see **Figure 89** with a 32-bit data access example).

The transmission cycle begins when the chip is selected by the input CSN (Chip Select Not), LOW active. After the CSN input returns from LOW to HIGH, the word that has been read is interpreted according to the content. The SDO output switches to tristate status (high impedance) at this point, thereby releasing the SDO bus for other use. The state of SDI is shifted into the input register with every falling edge on CLK. The state of SDO is shifted out of the output register after every rising edge on CLK. The SPI of the device is not daisy chain capable.

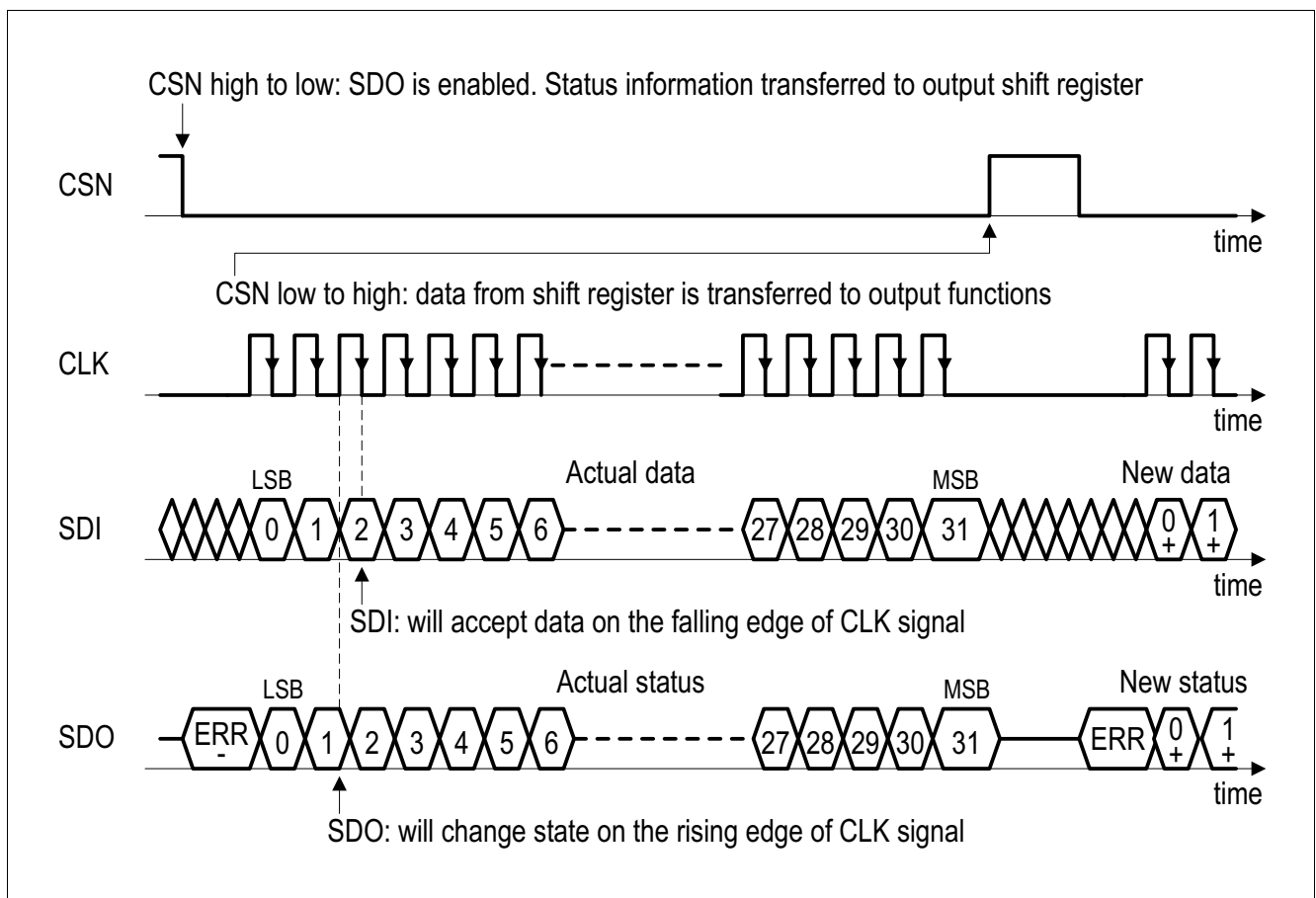

Figure 89 SPI Data Transfer Timing (note the reversed order of LSB and MSB shown in this figure compared to the register description)

14.2 Failure Signalization in the SPI Data Output

When the microcontroller sends a wrong SPI command to the device, the device ignores the information. Wrong SPI commands are either invalid device mode commands or commands which are prohibited by the state machine to avoid undesired device or system states (see below). In this case the diagnosis bit **SPI_FAIL** is set and the SPI Write command is ignored (no partial interpretation). This bit can be only reset by actively clearing it via a SPI command.

Invalid SPI Commands leading to SPI_FAIL are listed below (in this case the SPI command is ignored):

- Illegal state transitions:
 - Going from Stop Mode to Sleep Mode. In this case the device enters Restart Mode.
 - Trying to go to Stop Mode or Sleep Mode from Init Mode¹⁾. In this case Normal Mode is entered.
- Uneven parity in the data bit of the **WD_CTRL** register. In this case the watchdog trigger is ignored and/or the new watchdog settings are ignored respectively.
- In Stop Mode: attempting to change any SPI settings, e.g. changing the watchdog configuration, PWM settings and HSx configuration settings during Stop Mode, etc.; the SPI command is ignored in this case; only WD trigger, returning to Normal Mode, triggering a device soft reset, and read & clear status registers commands are valid SPI commands in Stop Mode; **Note:** No failure handling is done for the attempt to go to Stop Mode when all bits in the registers **BUS_CTRL** and **WK_CTRL** are cleared because the microcontroller can leave this mode via SPI.
- When entering Stop Mode and **WK_STAT** is not cleared; **SPI_FAIL** will not be set but the INTN pin will be triggered.
- Changing from Stop Mode to Normal Mode and changing the other bits of the **M_S_CTRL** register. The other modifications will be ignored.
- Sleep Mode: attempt to go to Sleep Mode without any wake source set, i.e. when all bits in the **BUS_CTRL** and **WK_CTRL** registers are cleared. In this case the **SPI_FAIL** bit is set and the device enters Restart Mode. Even though the Sleep Mode command is not entered in this case, the rest of the command is executed but restart values apply during Restart Mode; **Note:** At least one wake source must be activated in order to avoid a deadlock situation in Sleep Mode. If the only wake source is a timer and the timer is OFF, then the device will wake immediately from Sleep Mode and enter Restart Mode.
- Setting a longer or equal on-time than the timer period of the respective timer.
- SDI stuck at HIGH or LOW, e.g. SDI received all '0' or all '1'.
- Any attempt to configure again the **WK2_FO**.
- Configured the HSx controlled by SYNC when the WK4/SYNC is not configured as SYNC-input.

Note: There is no SPI fail information for unused addresses.

*Note: In case that the register or banking are accessed but they are not valid as address or banks, the **SPI_FAIL** is not triggered and the cmd is ignored.*

1) If the device is externally configured to use SPI with CRC (by PWM1/CRC pin), the attempt to go to Stop or Sleep from Init, will generate SPI_FAIL even if it is a SPI command with correct CRC. Still, the first SPI command will put the device from Init to Normal Mode even if CRC is not correct (CRC_FAIL status bit will be set).

Serial Peripheral Interface

Signalization of the ERR Flag (high active) in the SPI Data Output (see Figure 89):

The ERR flag presents an additional diagnosis possibility for the SPI communication. The ERR flag is being set for following conditions:

- in case the number of received SPI clocks is not 0 or 32.
- in case RSTN is LOW and SPI frames are being sent at the same time.

Note: In order to read the SPI ERR flag properly, CLK must be low when CSN is triggered, i.e. the ERR bit is not valid if the CLK is high on a falling edge of CSN.

The number of received SPI clocks is not 0 or 32:

The number of received input clocks is supervised to be 0 or 32 clock cycles and the input word is discarded in case of a mismatch (0 clock cycle to enable ERR signalization). The error logic also recognizes if CLK was high during CSN edges. Both errors (0 or 32 bit CLK mismatch or CLK high during CSN edges) are flagged in the following SPI output by a “HIGH” at the data output (SDO pin, bit ERR) before the first rising edge of the clock is received. The complete SPI command is ignored in this case.

RSTN is LOW and SPI frames are being sent at the same time:

The ERR flag will be set when the RSTN pin is triggered (during device restart) and SPI frames are being sent to the device at the same time. The behavior of the ERR flag will be signalized at the next SPI command for below conditions:

- If the command begins when RSTN is HIGH and it ends when RSTN is LOW.
- If a SPI command will be sent while RSTN is LOW.
- If a SPI command begins when RSTN is LOW and it ends when RSTN is HIGH.

And the SDO output will behave as follows:

- Always when RSTN is LOW then SDO will be HIGH.
- When a SPI command begins when RSTN is LOW and ends when RSTN is HIGH, then the SDO should be ignored because wrong data will be sent.

Note: It is possible to quickly check for the ERR flag without sending any data bits. i.e. only the CSN is pulled low and SDO is observed - no SPI Clocks are sent in this case.

Note: The ERR flag could also be set after the device has entered Fail-Safe Mode because the SPI communication is stopped immediately.

Serial Peripheral Interface

14.3 SPI Programming

For the TLE9562-3QX, 7 bits are used for the address selection (BIT 6...0). Bit 7 is used to decide between Read Only and Read & Clear for the status bits, and between Write and Read Only for configuration bits. For the actual configuration and status information, 16 data bits (BIT 23...8) are used.

Writing, clearing and reading is done word wise. The SPI status bits are not cleared automatically and must be cleared by the microcontroller. Some of the configuration bits will automatically be cleared by the device (refer to the respective register descriptions for detailed information). In Restart Mode, the device ignores all SPI communication, i.e. it does not interpret it.

There are two types of SPI registers:

- Control registers: These registers are used to configure the device, e.g. mode, watchdog trigger, etc.
- Status registers: These registers indicate the status of the device, e.g. wake events, warnings, failures, etc.

For the status registers, the requested information is given in the same SPI command in the data out (SDO). For the control registers, the status of each byte is shown in the same SPI command as well. However, configuration changes of the same register are only shown in the next SPI command (configuration changes inside the device become valid only after CSN changes from low to high). See [Figure 90](#).

Writing of control registers is possible in Init and Normal Mode. During Stop Mode only the change to Normal Mode and triggering the watchdog is allowed as well as reading and clearing the status registers.

No status information can be lost, even if a bit changes right after the first 7 SPI clock cycles before the SPI frame ends. In this case the status information field will be updated with the next SPI command. However, the flag is already set in the relevant status register. The device status information from the SPI status registers is transmitted in a compressed format with each SPI response on SDO in the so-called Status Information Field register (see also [Table 40](#)). The purpose of this register is to quickly signal changes in dedicated SPI status registers to the microcontroller.

Table 40 Status Information Field

Bit in Status Information Field	Corresponding Address Bit	Status Register Description
0		SUPPLY_STAT = OR of all bits on SUP_STAT register
1		TEMP_STAT = OR of all bits on THERM_STAT register
2		BUS_STAT = OR of all bits on BUS_STAT register
3		WAKE_UP = OR of all bits on WK_STAT register
4		HS_STAT = OR of all bits on HS_OL_OC_OT_STAT register
5		DEV_STAT = OR of all bits on DEV_STAT except CRC_STAT and SW_DEV
6		BD_STAT = OR of all bits on DSOV register
7		SPI_CRC_FAIL = (SPI_FAIL) OR (CRC_FAIL)

Serial Peripheral Interface



Figure 90 SPI Operation Mode

14.3.1 CRC

The SPI interface includes also 8 Bits (bits 24 to 31) used for Cyclic Redundancy Check (CRC) to ensure data integrity on sent or received SPI command.

The implemented CRC is based on Autosar specification of CRC Routines revision 4.3.0 and in particular the function CRC8-2FH.

The specification are based on the follow table:

Table 41 CRC8x2FH definition

CRC result width:	8 bits
Polynomial	2F _H
Initial Value	FF _H
Input data reflected	No
Result data reflected	No
XOR value	FF _H
Check	DF _H
Magic check	42 _H

Some examples of CRC calculation are shown in the follow table:

Table 42 CRC8x2FH calculation example

Data Bytes (hexadecimal)									CRC
00	00	00	00						12
F2	01	83							C2
0F	AA	00	55						C6
00	FF	55	11						77
33	22	55	AA	BB	CC	DD	EE	FF	11
92	6B	55							33
FF	FF	FF	FF						6C

Serial Peripheral Interface

Polynomial

The polynomial is:

$$x^8 + x^5 + x^3 + x^2 + x^1 + x^0 \tag{14.1}$$

Calculation in SDI and SDO

The calculation of the CRC is done considering the first 24 bits (BIT 0..23) either of SDI or SDO.

The content of SDO Payload (BIT 8..23) is referring the previous data written at the addressed register via SDI.

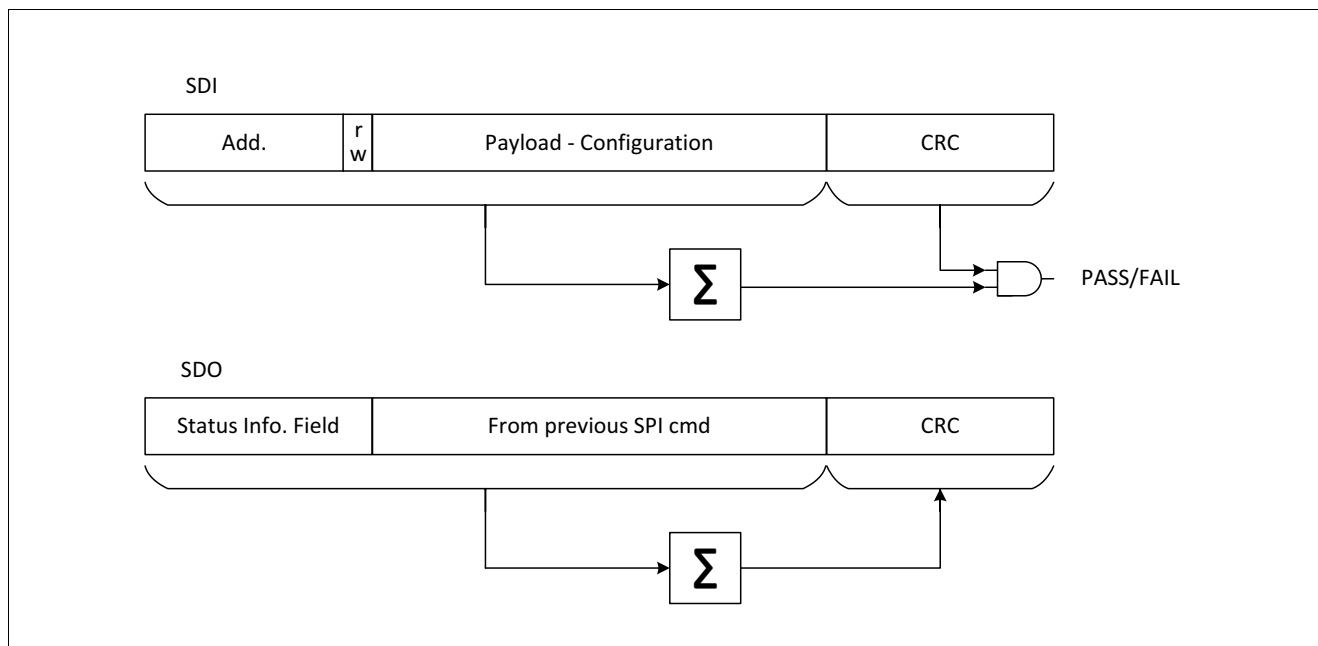

Figure 91 CRC calculation

CRC Activation and status information

For CRC activation, refer to [Chapter 5.2](#).

The CRC status ([CRC_STAT](#)) and failure ([CRC_FAIL](#)) are readable on [DEV_STAT](#).

Read out of the register which contains the [CRC_STAT](#) and [CRC_FAIL](#) is done ignoring the CRC field and no failure flag are set.

The [DEV_STAT](#) register shall be cleared considering the CRC setting (ON or OFF).

The [CRC_STAT](#) bit is read only.

The [CRC_FAIL](#) is set in the follow conditions:

- If the CRC is enabled and the μ C sends wrong CRC field.
- If the CRC is disabled and the μ C sends wrong static pattern (no A5_H).

CRC field in case of CRC disabled

In case that the CRC is not activated, the bits needed for CRC field have to be filled with static pattern.

In case of SDI, the CRC field has to be filled with A5_H (bits 24:31).

In case of SDO, the device will always answer with 5A_H (bits 24:31).

The status of the CRC is updated accordingly in [CRC_STAT](#) bit.

14.4 SPI Bit Mapping

The following figures show the mapping of the registers and the SPI bits of the respective registers.

The Control Registers are Read/Write Register with the following structure:

- Device Control Registers from 000 0001_B to 000 1011_B.
- Bridge Driver Control Registers from 001 0000_B to 001 1101_B.
- SWK Control Registers from 011 0000_B to 011 1111_B.

Depending on bit 7 the bits are only read (setting bit 7 to '0') or also written (setting bit 7 to '1'). The new setting of the bit after a write can be seen with a new read / write command.

The Status Registers are Read/Clear with the following structure:

- Device Status Registers from 100 0000_B to 100 0110_B.
- Bridge Driver Status Registers from 101 0000_B to 101 1011_B.
- SWK Status Registers from 110 0000_B to 110 0011_B.
- Product Family is 111 0000_B.

The registers can be read or can be cleared (if clearing is possible) depending on bit 7. To clear the payload of one of the Status Registers bit 7 must be set to 1.

The registers **WK_LVL_STAT**, and **FAM_PROD_STAT**, **SWK_OSC_CAL_STAT**, **SWK_ECNT_STAT**, **SWK_CDR_STAT** are an exception as they show the actual voltage level at the respective WKx pin (LOW/HIGH), or a fixed family/ product ID respectively and can thus not be cleared.

It is recommended for proper diagnosis to clear respective status bits for wake events or failure.

When changing to a different device mode, certain configurations bits will be cleared automatically or modified:

- The device mode bits are updated to the actual status, e.g. when returning to Normal Mode.
- When changing to a low-power mode (Stop Mode or Sleep Mode), the diagnosis bits of the integrated module are not cleared.
- When changing to Stop Mode, the CAN, LIN control bits will not be modified.
- When changing to Sleep Mode, the CAN, LIN control bits will be modified if they were not OFF or wake capable before.
- FO will stay activated if it was triggered before. Depending on the respective configuration, CAN, LIN transceivers will be either OFF, woken or still wake capable.

Note: The detailed behavior of the respective SPI bits and control functions is described in [Chapter 14.5](#), [Chapter 14.6](#) and in the respective module chapter. The bit type be marked as 'rwh' in case the device will modify respective control bits.

Serial Peripheral Interface

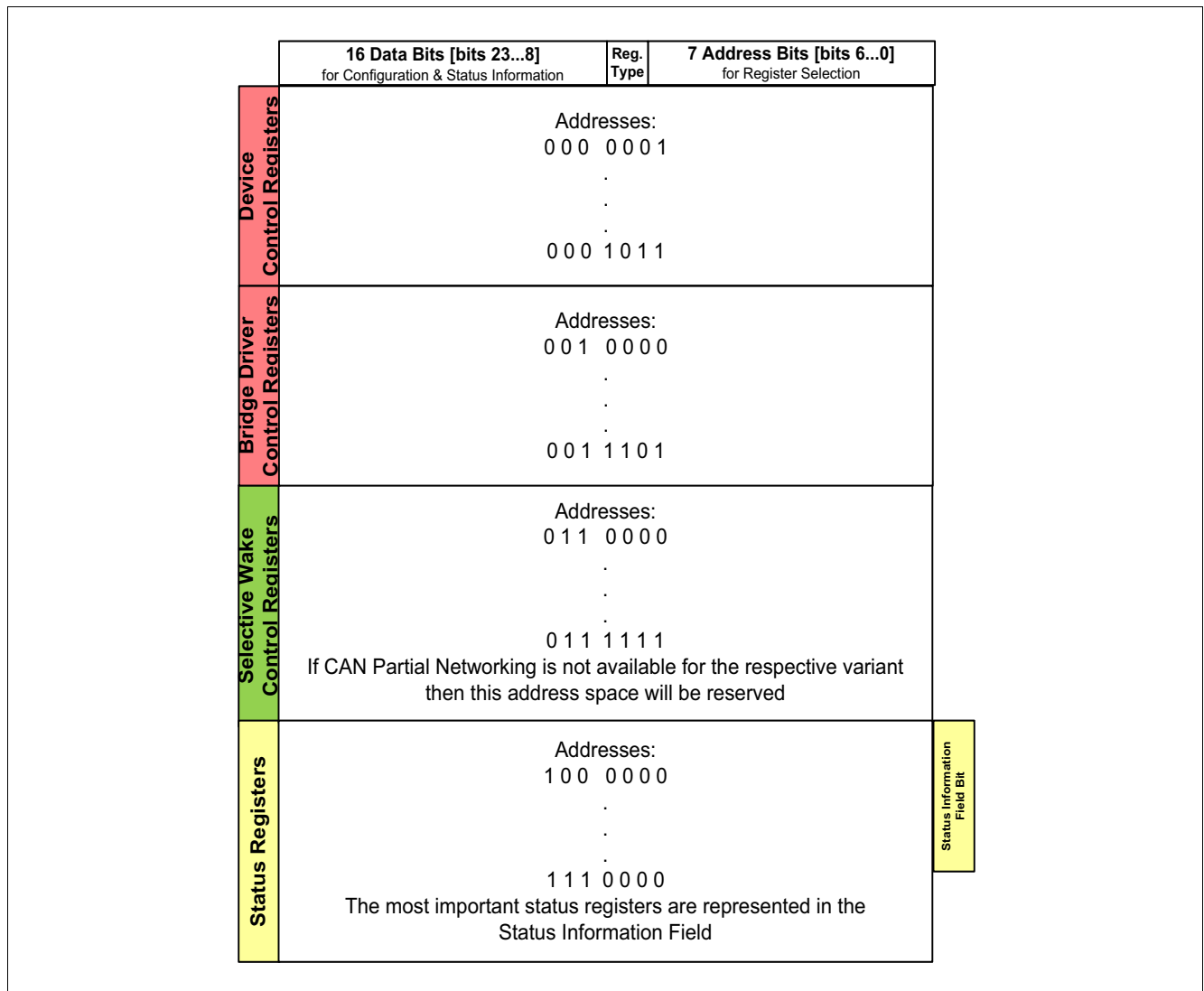

Figure 92 SPI Register Mapping Structure

The detailed register mappings for control registers and status registers are shown in [Table 43](#) and [Table 86](#) respectively.

14.4.1 Register Banking

In order to minimize the number of configuration registers, seven registers follow a bank structure.

The banked registers are:

- [WK_CTRL](#)
- [PWM_CTRL](#)
- [CCP_BLK](#)
- [TPRECHG](#)
- [HB_ICHG](#)
- [HB_PCHG_INIT](#)
- [TDON_HB_CTRL](#)
- [TDOFF_HB_CTRL](#)

Serial Peripheral Interface

In these register, the first 3 bits of the payload (bit 8 to 10) select the bank that has to be configured. The rest of the payload is used to configure the selected bank (for more details refer to the specific banked register).

In case that CRC is used, the CRC calculation is done considering the first 24 bits (from bit 0 to 23).

The banked registers can be read like the other configuration registers but in the SDO one '0' is automatically added after the status information field. **Figure 93** shows the structure of SDO in banked register.

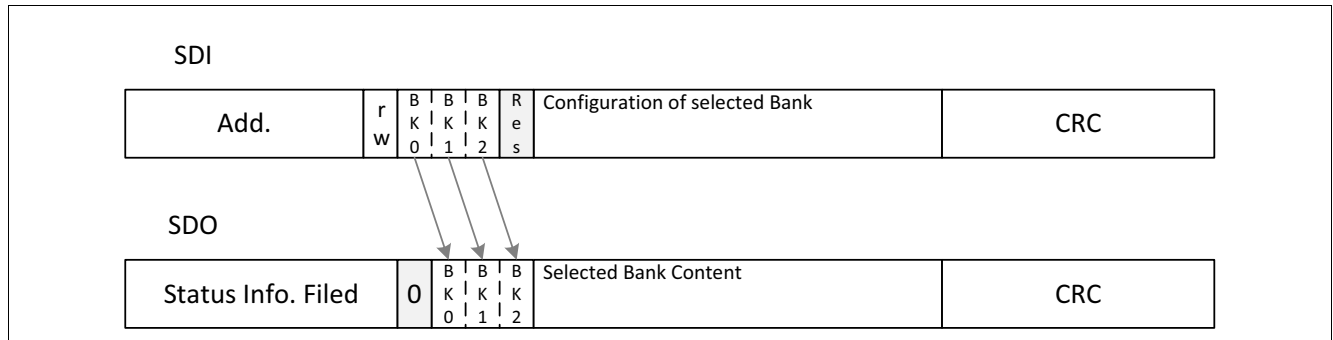

Figure 93 Register read Out of banked register (3 bit banking)

Serial Peripheral Interface

14.5 SPI control registers

READ/WRITE Operation (see also [Chapter 14.3](#)):

- The ‘POR / Soft Reset Value’ defines the register content after POR or device reset.
- The ‘Restart Value’ defines the register content after device restart, where ‘x’ means the bit is unchanged.
- There are different bit types:
 - ‘r’ = READ: read only bits (or reserved bits).
 - ‘rw’ = READ/WRITE: readable and writable bits.
 - ‘rwh’ = READ/WRITE/Hardware: readable/writable bits, which can also be modified by the device hardware.
- Reserved bits are marked as “Reserved” and always read as “0”. The respective bits shall also be programmed as “0”.
- Reading a register is done word wise by setting the SPI bit 7 to “0” (= Read Only).
- SPI control bits are in general not cleared or changed automatically. This must be done by the microcontroller via SPI programming. Exceptions to this behavior are stated at the respective register description and the respective bit type is marked with a ‘h’ meaning that the device is able to change the register content.

The registers are addressed wordwise.

Table 43 Register Overview

Register Short Name	Register Long Name	Offset Address	Page Number
SPI control registers, Device Control Registers			
M_S_CTRL	Mode and Supply Control	0000001 _B	188
HW_CTRL	Hardware Control	0000010 _B	190
WD_CTRL	Watchdog Control	0000011 _B	192
BUS_CTRL	CAN and LIN Control	0000100 _B	194
WK_CTRL	Wake-up Control	0000101 _B	196
TIMER_CTRL	Timer 1 and Timer 2 Control and Selection	0000110 _B	198
SW_SD_CTRL	High-Side Switch Shutdown Control	0000111 _B	200
HS_CTRL	High-Side Switch Control	0001000 _B	203
INT_MASK	Interrupt Mask Control	0001001 _B	205
PWM_CTRL	PWM Configuration Control	0001010 _B	207
SYS_STAT_CTRL	System Status Control	0001011 _B	208
SPI control registers, Control registers bridge driver			
GENCTRL	General Bridge Control	0010000 _B	209
LS_VDS	Drain-Source monitoring threshold	0010010 _B	211
HS_VDS	Drain-Source monitoring threshold	0010011 _B	213
CCP_BLK	CCP and times selection	0010100 _B	215
HBMODE	Half-Bridge MODE	0010101 _B	216
TPRECHG	PWM pre-charge and pre-discharge time	0010110 _B	218
ST_ICHG	Static charge/discharge current	0010111 _B	220

Serial Peripheral Interface

Table 43 Register Overview (cont'd)

Register Short Name	Register Long Name	Offset Address	Page Number
HB_ICHG	PWM charge/discharge current	0011000 _B	221
HB_ICHG_MAX	PWM max. pre-charge/pre-discharge current and diagnostic pull-down	0011001 _B	222
HB_PCHG_INIT	PWM pre-charge/pre-discharge initialization	0011010 _B	224
TDON_HB_CTRL	PWM inputs TON configuration	0011011 _B	225
TDOFF_HB_CTRL	PWM inputs TOFF configuration	0011100 _B	226
BRAKE	Brake control	0011101 _B	227
SPI control registers, Selective Wake Registers			
SWK_CTRL	CAN Selective Wake Control	0110000 _B	229
SWK_BTL1_CTRL	SWK Bit Timing Control	0110001 _B	230
SWK_ID1_CTRL	SWK WUF Identifier bits 28...13	0110010 _B	231
SWK_ID0_CTRL	SWK WUF Identifier bits 12...0	0110011 _B	232
SWK_MASK_ID1_CTRL	SWK WUF Identifier Mask bits 28...13	0110100 _B	233
SWK_MASK_ID0_CTRL	SWK WUF Identifier Mask bits 12...0	0110101 _B	235
SWK_DLC_CTRL	SWK Frame Data Length Code Control	0110110 _B	237
SWK_DATA3_CTRL	SWK Data7-Data6 Register	0110111 _B	238
SWK_DATA2_CTRL	SWK Data5-Data4 Register	0111000 _B	239
SWK_DATA1_CTRL	SWK Data3-Data2 Register	0111001 _B	240
SWK_DATA0_CTRL	SWK Data1-Data0 Register	0111010 _B	241
SWK_CAN_FD_CTRL	CAN FD Configuration Control Register	0111011 _B	242
SPI control registers, Selective Wake trim and configuration Registers			
SWK_OSC_TRIM_CTRL	SWK Oscillator Trimming and option Register	0111100 _B	243
SWK_OSC_CAL_STAT	SWK Oscillator Calibration Register	0111101 _B	244
SWK_CDR_CTRL	Clock Data Recovery Control Register	0111110 _B	245
SWK_CDR_LIMIT	SWK Clock Data Recovery Limit Control	0111111 _B	247

Serial Peripheral Interface

14.5.1 Device Control Registers

Mode and Supply Control

M_S_CTRL

Mode and Supply Control

(000 0001_B)

Reset Value: see [Table 44](#)

15	14	13	12	11	10	9	8	7	6	5	4	3	2	1	0
MODE		RES		VCC1_OV_MOD		RES	RSTN_HYS	RES	I_PEAK_TH	RES			VCC1_RT		
rwh		r		rwh		r	rw	r	rw	r			rw		

Field	Bits	Type	Description
MODE	15:14	rwh	Device Mode Control 00 _B NORMAL , Normal Mode 01 _B SLEEP , Sleep Mode 10 _B STOP , Stop Mode 11 _B RESET , Device reset: Soft reset is executed (configuration of RSTN triggering in bit SOFT_RESET_RO)
RES	13:11	r	Reserved, always reads as 0
VCC1_OV_MOD	10:9	rwh	Reaction in case of VCC1 Over Voltage 00 _B NO , no reaction 01 _B INTN , INTN event is generated 10 _B RSTN , RSTN event is generated 11 _B FAILSAFE , Fail-Safe Mode is entered
RES	8	r	Reserved, always reads as 0
RSTN_HYS	7	rw	VCC1 Undervoltage Reset Hysteresis Selection (see also Chapter 13.7.1 for more information) 0 _B DEFAULT , default hysteresis applies as specified in the electrical characteristics table 1 _B HIGHEST , the highest rising threshold (VRT1,R) is always used for the release of the undervoltage reset
RES	6	r	Reserved, always reads as 0
I_PEAK_TH	5	rw	VCC1 Active Peak Threshold Selection 0 _B LOW , low VCC1 active peak threshold selected 1 _B HIGH , high VCC1 active peak threshold selected
RES	4:2	r	Reserved, always reads as 0
VCC1_RT	1:0	rw	VCC1 Reset Threshold Control 00 _B VRT1 , Vrt1 selected (highest threshold) 01 _B VRT2 , Vrt2 selected 10 _B VRT3 , Vrt3 selected 11 _B VRT4 , Vrt4 selected

Serial Peripheral Interface

Table 44 Reset of **M_S_CTRL**

Register Reset Type	Reset Values	Reset Short Name	Reset Mode	Note
POR/Soft reset	0000 0000 0000 0000 _B			
Restart	0000 0000 x0x0 00xx _B			

Notes

1. *It is not possible to change from Stop Mode to Sleep Mode via SPI Command. See also the State Machine Chapter.*
2. *After entering Restart Mode, the MODE bits will be automatically set to Normal Mode.*
3. *The SPI output will always show the previously written state with a Write Command (what has been programmed before).*

Serial Peripheral Interface

Hardware Control

HW_CTRL

Hardware Control

(000 0010_B)

Reset Value: see [Table 45](#)

15	14	13	12	11	10	9	8	7	6	5	4	3	2	1	0
RES		TSD2_DEL	VS_OV_SEL	SH_DISABLE	RSTN_DEL	RES		SOFT_RESET_RO	FO_ON	RES		WD_STM_EN_1	RES		
r		rw	rw	rw	rw	r		rw	rwh	r		rwh	r		

Field	Bits	Type	Description
RES	15:13	r	Reserved, always reads as 0
TSD2_DEL	12	rw	TSD2 minimum Waiting Time Selection 0 _B 1s , Minimum waiting time until TSD2 is released again is always 1 s 1 _B 64s , Minimum waiting time until TSD2 is released again is 1 s, after >16 TSD2 consecutive events, it will extended x 64
VS_OV_SEL	11	rw	VS OV comparator threshold change 0 _B 20V , Default threshold setting ($V_{S,OVD1}$) 1 _B 30V , increased threshold setting ($V_{S,OVD2}$)
SH_DISABLE	10	rw	Sample and hold circuitry disable 0 _B ENABLED , Gate driver S&H circuitry enabled 1 _B DISABLED , Gate driver S&H circuitry disabled
RSTN_DEL	9	rw	Reset delay time 0 _B 10ms , Reset delay time 10 ms (t_{RD1}) 1 _B 2ms , Reset delay time to 2 ms (t_{RD2})
RES	8:7	r	Reserved, always reads as 0
SOFT_RESET_RO	6	rw	Soft Reset Configuration 0 _B RSTN , RSTN will be triggered (pulled low) during a Soft Reset 1 _B NO_RSTN , no RSTN trigger during a Soft Reset
FO_ON	5	rwh	Failure Output Activation 0 _B DISABLED , FO not activated by software, FO will be activated by specified failures 1 _B ENABLED , FO activated by software (via SPI), only if WK2/FO pin is configured as Fail Safe Output
RES	4:3	r	Reserved, always reads as 0
WD_STM_EN_1	2	rwh	Watchdog Deactivation during Stop Mode, bit1 0 _B ACTIVE , Watchdog is active in Stop Mode 1 _B INACTIVE , Watchdog is deactivated in Stop Mode
RES	1:0	r	Reserved, always reads as 0

Serial Peripheral Interface

Table 45 Reset of **HW_CTRL**

Register Reset Type	Reset Values	Reset Short Name	Reset Mode	Note
POR	0000 0000 0000 0000 _B			
Soft reset	0000 00x0 0000 0000 _B			
Restart	000x 00x0 0x00 0000 _B			

Notes

1. *Clearing the FO_ON bit will not disable the FO outputs in case a failure occurred which triggered the FO outputs. In this case the FO outputs have to be disabled by clearing the FAILURE bit.
 If the FO_ON bit is set by the software then it will be cleared by the device after Restart Mode was entered and the FO outputs will be disabled (if no failures occurred which triggered the fail outputs).*
2. *WD_STM_EN_1 will also be cleared when changing from Stop Mode to Normal Mode .*

Serial Peripheral Interface

Watchdog Control

WD_CTRL

Watchdog Control

(000 0011_B)

Reset Value: see [Table 46](#)

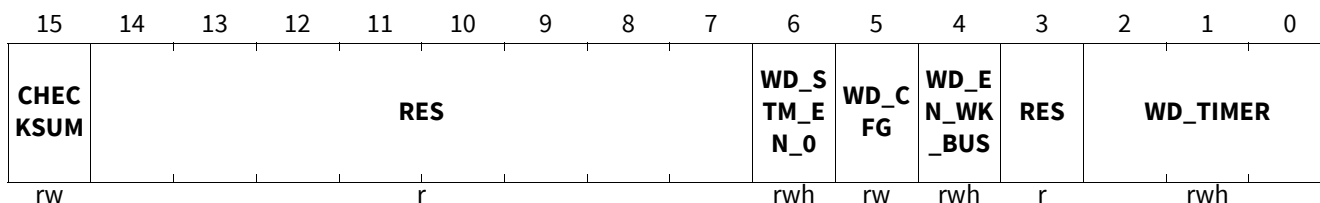

Field	Bits	Type	Description
CHECKSUM	15	rw	Watchdog Setting Check Sum Bit 0 _B 0, Counts as 0 for checksum calculation 1 _B 1, Counts as 1 for checksum calculation
RES	14:7	r	Reserved, always reads as 0
WD_STM_EN_0	6	rwh	Watchdog Deactivation during Stop Mode, bit0 0 _B ACTIVE , Watchdog is active in Stop Mode 1 _B INACTIVE , Watchdog is deactivated in Stop Mode
WD_CFG	5	rw	Watchdog Configuration 0 _B TIMEOUT , Watchdog works as a Time-Out watchdog 1 _B WINDOW , Watchdog works as a Window watchdog
WD_EN_WK_BUS	4	rwh	Watchdog Enable after Bus Wake in Stop Mode 0 _B DISABLED , Watchdog will not start after a CAN or LIN wake-up event 1 _B ENABLED , Watchdog starts with a long open window after CAN or LIN Wake-up event
RES	3	r	Reserved, always reads as 0
WD_TIMER	2:0	rwh	Watchdog Timer Period 000 _B 10ms , 10ms 001 _B 20ms , 20ms 010 _B 50ms , 50ms 011 _B 100ms , 100ms 100 _B 200ms , 200ms 101 _B 500ms , 500ms 110 _B 1s , 1s 111 _B 10s , 10s

Table 46 Reset of [WD_CTRL](#)

Register Reset Type	Reset Values	Reset Short Name	Reset Mode	Note
POR/Soft reset	0000 0000 0001 0100 _B			
Restart	0000 0000 000x 0100 _B			

Serial Peripheral Interface

Notes

1. See also [Chapter 13.2.4](#) for more information on disabling the watchdog in Stop Mode.
2. See chapter [Chapter 13.2.5](#) for more information on the effect of the bit `WD_EN_WK_BUS`.
3. See chapter [Chapter 13.2.3](#) for calculation of checksum.

Serial Peripheral Interface

CAN and LIN Control

BUS_CTRL

CAN and LIN Control

(000 0100_B)

Reset Value: see Table 47

15	14	13	12	11	10	9	8	7	6	5	4	3	2	1	0	
RES								LIN_F LASH	LIN_L SM	LIN_T XD_T O	LIN			CAN		
r								rw	rw	rw	rwh			rwh		

Field	Bits	Type	Description
RES	15:8	r	Reserved, always reads as 0
LIN_FLASH	7	rw	LIN Flash 0 _B ACTIVE , Slope control mechanism active 1 _B INACTIVE , Deactivation of slope control for baudrates up to 115 kBaud
LIN_LSM	6	rw	LIN LSM 0 _B NORMAL , LIN Normal Mode is activated 1 _B LOW_SLOPE , LIN Low-Slope Mode (10.4 kBaud) activated
LIN_TXD_TO	5	rw	LIN TXD TO 0 _B DISABLED , TXD Time-out feature disabled 1 _B ENABLED , TXD Time-out feature enabled
LIN	4:3	rwh	LIN Module Modes 00 _B OFF , LIN OFF 01 _B WAKE , LIN wake capable 10 _B RECEIVE , LIN Receive Only Mode 11 _B NORMAL , LIN Normal Mode
CAN	2:0	rwh	HS-CAN Module Modes 000 _B OFF , CAN OFF 001 _B WAKE , CAN is wake capable (no SWK) 010 _B RECEIVE , CAN Receive Only Mode (no SWK) 011 _B NORMAL , CAN Normal Mode (no SWK) 100 _B OFF , CAN OFF 101 _B WAKE_SWK , CAN is wake capable with SWK 110 _B RECEIVE_SWK , CAN Receive Only Mode with SWK 111 _B NORMAL_SWK , CAN Normal Mode with SWK

Table 47 Reset of BUS_CTRL

Register Reset Type	Reset Values	Reset Short Name	Reset Mode	Note
POR/Soft reset	0000 0000 0000 0000 _B			
Restart	0000 0000 xx0y 0x00 _B			

Serial Peripheral Interface

Notes

1. The reset values for CAN, LIN transceivers are marked with 'y' because they will vary depending on the cause of change.
2. See [Figure 30](#), [Figure 37](#) for detailed state changes of CAN, LIN transceivers for different device modes.
3. The bit CAN_2 is not modified by the device but can only be changed by the user. Therefore, the bit type is 'rw' compared to bits CAN_0 and CAN_1.
4. In case SYSERR = 0 and the CAN transceiver is configured to 'x11' while going to Sleep Mode, it will be automatically set to wake capable ('x01'). The SPI bits will be changed to wake capable. If configured to 'x10' and Sleep Mode is entered, then the transceiver is set to wake capable, while it will stay in Receive Only Mode when it had been configured to 'x10' when going to Stop Mode. If it had been configured to wake capable or OFF then the mode will remain unchanged. The Receive Only Mode has to be selected by the user before entering Stop Mode. Please refer to [Chapter 5.9](#) for detailed information on the Selective Wake Mode changes.
5. Failure Handling Mechanism: When the device enters Fail-Safe Mode due to a failure, then **BUS_CTRL** is modified by the device to 0000 0000 xxx0 1001_B to ensure that the device can be woken again. See also the description in [Chapter 8.1](#), [Chapter 9.1](#) and [Chapter 10.2.1](#) for **WK_CTRL** for other wake sources when entering Fail-Safe Mode.
6. When in Software Development Mode the POR/Soft Reset value are: CAN=001_B, LIN=11_B.

Serial Peripheral Interface

Wake-up Control

WK_CTRL

Wake-up Control

(000 0101_B)

Reset Value: see [Table 48](#)

15	14	13	12	11	10	9	8	7	6	5	4	3	2	1	0
WK2_FO	RES	WK_FILT		WK_PUPD		RES	WK_EN		RES	WK_BNK					
rw	r	rw		rw		r	rw		r	rw					

Field	Bits	Type	Description
WK2_FO	15	rw	WK2 / FO configuration 0 _B FAIL_SAFE , WK2/FO pin configured as Fail Safe Output 1 _B WAKE_UP , WK2/FO pin configured as Wake-up Input
RES	14	r	Reserved, always reads as 0
WK_FILT	13:11	rw	Wake-up Filter Time Configuration 000 _B 16us , Filter with 16 μs filter time (static sensing) 001 _B 64us , Filter with 64 μs filter time (static sensing) 010 _B TIMER1 , Filtering at the end of the on-time; filter time of 16 μs (cyclic sensing) is selected, Timer1 011 _B TIMER2 , Filtering at the end of the on-time; filter time of 16 μs (cyclic sensing) is selected, Timer2 100 _B SYNC , Filter at the end of settle time (80 μs), filter time of 16 μs (cyclic sensing) is selected, SYNC ¹⁾²⁾ 101 _B , reserved 110 _B , reserved 111 _B , reserved
WK_PUPD	10:9	rw	WKx Pull-Up/Pull-Down Configuration 00 _B NO , No pull-up/pull-down selected 01 _B PULL_DOWN , Pull-down resistor selected 10 _B PULL_UP , Pull-up resistor selected 11 _B AUTO , Automatic switching to pull-up or pull-down
RES	8:7	r	Reserved, always reads as 0
WK_EN	6:5	rw	WKx Enable 00 _B WK_OFF , WKx module OFF 01 _B WK_ON , WKx module ON 10 _B SYNC , OFF or (in case of WK4), it is configured as SYNC input 11 _B OFF , OFF
RES	4:3	r	Reserved, always reads as 0

Serial Peripheral Interface

Field	Bits	Type	Description
WK_BNK	2:0	rw	WKs input Banking 000 _B WK1 , WK1 Module (Bank 1) 001 _B WK2 , WK2 Module (Bank 2) 010 _B WK3 , WK3 Module (Bank 3) 011 _B WK4 , WK4 Module (Bank 4) 101 _B , reserved 110 _B , reserved 111 _B , reserved

- 1) This setting is available only in case of WK4 configured as **WK_EN**=10_B.
- 2) The min TON time for cyclic sense with SYNC is 100 µs.

Table 48 Reset of **WK_CTRL**

Register Reset Type	Reset Values	Reset Short Name	Reset Mode	Note
POR/Soft reset	0000 0000 0010 0000 _B			
Restart	x0xx xxx0 0xx0 0000 _B			

Notes

1. **WK2_FO** bit is accessible only if the Bank 2 is selected.
2. The SYNC functionality is accessible only if the Bank 4 is selected.
3. When selecting a filter time configuration, the user must make sure to also assign the respective timer/SYNC to at least one HS switch during cyclic sense operation.
4. At Fail-Safe Mode entry **WK_EN** will be automatically changed (by the device) in "01".
 Exceptions: WK2 is configured as FO and WK4 if configured as SYNC previously
5. During Fail-Safe Mode the **WK_FILT** bits are ignored and static-sense with 16 µs filter time is used by default.

Serial Peripheral Interface

Timer 1 and Timer2 Control and Selection

TIMER_CTRL

Timer 1 and Timer2 Control and Selection (000 0110_B)

Reset Value: see Table 49

15	14	13	12	11	10	9	8	7	6	5	4	3	2	1	0
TIMER2_ON			RES	TIMER2_PER			CYCWK	TIMER1_ON			RES	TIMER1_PER			
rwh			r	rwh			rwh	rwh			r	rwh			

Field	Bits	Type	Description
TIMER2_ON	15:13	rwh	Timer2 On-Time Configuration 000 _B OFF_LOW , OFF / Low (timer not running, HSx output is low) 001 _B 100us , 0.1ms on-time 010 _B 300us , 0.3ms on-time 011 _B 1ms , 1.0ms on-time 100 _B 10ms , 10ms on-time 101 _B 20ms , 20ms on-time 110 _B OFF_HIGH , OFF / HIGH (timer not running, HSx output is high) 111 _B , reserved, same behaviour as 110 _B
RES	12	r	Reserved, always reads as 0
TIMER2_PER	11:9	rwh	Timer2 Period Configuration 000 _B 10ms , 10ms 001 _B 20ms , 20ms 010 _B 50ms , 50ms 011 _B 100ms , 100ms 100 _B 200ms , 200ms 101 _B 500ms , 500ms 110 _B 1s , 1s 111 _B 2s , 2s
CYCWK	8:7	rwh	Cyclic Wake Configuration 00 _B DISABLED , Timer1 and Timer2 disabled as wake-up sources 01 _B TIMER1 , Timer1 is enabled as wake-up source (Cyclic Wake) 10 _B TIMER2 , Timer2 is enabled as wake-up source (Cyclic Wake) 11 _B , reserved

Serial Peripheral Interface

Field	Bits	Type	Description
TIMER1_ON	6:4	rwh	Timer1 On-Time Configuration 000 _B OFF_LOW , OFF / Low (timer not running, HSx output is low) 001 _B 100us , 0.1ms on-time 010 _B 300us , 0.3ms on-time 011 _B 1ms , 1.0ms on-time 100 _B 10ms , 10ms on-time 101 _B 20ms , 20ms on-time 110 _B OFF_HIGH , OFF / HIGH (timer not running, HSx output is high) 111 _B , reserved, same behaviour as 110 _B
RES	3	r	Reserved, always reads as 0
TIMER1_PER	2:0	rwh	Timer1 Period Configuration 000 _B 10ms , 10ms 001 _B 20ms , 20ms 010 _B 50ms , 50ms 011 _B 100ms , 100ms 100 _B 200ms , 200ms 101 _B 500ms , 500ms 110 _B 1s , 1s 111 _B 2s , 2s

Table 49 Reset of **TIMER_CTRL**

Register Reset Type	Reset Values	Reset Short Name	Reset Mode	Note
POR/Soft reset	0000 0000 0000 0000 _B			
Restart	0000 0000 0000 0000 _B			

Notes

1. The timer must be first assigned and is then automatically activated as soon as the on-time is configured.
2. If cyclic sense is selected and the HSx switch is cleared during Restart Mode then also the timer settings (period and on-time) are cleared to avoid incorrect switch detection. However, the timer settings are not cleared in case of failure not leading to Restart Mode.
3. In case the timer is set as wake sources and cyclic sense is running, then both cyclic sense and cyclic wake will be active at the same time.
4. Timer accuracy is linked to the oscillator accuracy (see Parameter P_13.12.43).

Serial Peripheral Interface

High-Side Switch Shutdown Control

SW_SD_CTRL

High-Side Switch Shutdown Control

(000 0111_B)

Reset Value: see [Table 50](#)

15	14	13	12	11	10	9	8	7	6	5	4	3	2	1	0
HS4_OV_REC	HS3_OV_REC	HS2_OV_REC	HS1_OV_REC	HS_OT_SD_DIS	HS4_OV_SDN_DIS	HS3_OV_SDN_DIS	HS2_OV_SDN_DIS	HS1_OV_SDN_DIS	HS_OV_SDN_DIS	HS_UV_SD_DIS	RES	HS_UV_REC		RES	
rw	rw	rw	rw	rw	rw	rw	rw	rw	rw	rw	r	rw		r	

Field	Bits	Type	Description
HS4_OV_REC	15	rw	<p>Switch recovery after removal of VSHS Overvoltage for HS4</p> <p>0_B DISABLED, Switch recovery is disabled 1_B PREVIOUS, Previous state before VSHS Overvoltage is enabled after Overvoltage condition is removed</p>
HS3_OV_REC	14	rw	<p>Switch recovery after removal of VSHS Overvoltage for HS3</p> <p>0_B DISABLED, Switch recovery is disabled 1_B PREVIOUS, Previous state before VSHS Overvoltage is enabled after Overvoltage condition is removed</p>
HS2_OV_REC	13	rw	<p>Switch recovery after removal of VSHS Overvoltage for HS2</p> <p>0_B DISABLED, Switch recovery is disabled 1_B PREVIOUS, Previous state before VSHS Overvoltage is enabled after Overvoltage condition is removed</p>
HS1_OV_REC	12	rw	<p>Switch recovery after removal of VSHS Overvoltage for HS1</p> <p>0_B DISABLED, Switch recovery is disabled 1_B PREVIOUS, Previous state before VSHS Overvoltage is enabled after Overvoltage condition is removed</p>
HS_OT_SD_DIS	11	rw	<p>Shutdown Disabling of all HS in case of Overtemperature event</p> <p>0_B ALL, shutdown for all HSx in case of Overtemperature 1_B INDIVIDUAL, individual shutdown in case of Overtemperature</p>

Serial Peripheral Interface

Field	Bits	Type	Description
HS4_OV_SDN_DIS	10	rw	Shutdown Disabling of HS4 in case of input supply overvoltage in Normal Mode 0 _B ENABLED , shutdown enabled in case of VSHS Overvoltage 1 _B DISABLED , shutdown disabled in case of VSHS Overvoltage
HS3_OV_SDN_DIS	9	rw	Shutdown Disabling of HS3 in case of input supply overvoltage in Normal Mode 0 _B ENABLED , shutdown enabled in case of VSHS Overvoltage 1 _B DISABLED , shutdown disabled in case of VSHS Overvoltage
HS2_OV_SDN_DIS	8	rw	Shutdown Disabling of HS2 in case of input supply overvoltage in Normal Mode 0 _B ENABLED , shutdown enabled in case of VSHS Overvoltage 1 _B DIASBLED , shutdown disabled in case of VSHS Overvoltage
HS1_OV_SDN_DIS	7	rw	Shutdown Disabling of HS1 in case of input supply overvoltage in Normal Mode 0 _B ENABLED , shutdown enabled in case of VSHS Overvoltage 1 _B DISABLED , shutdown disabled in case of VSHS Overvoltage
HS_OV_SDS_DIS	6	rw	Shutdown Disabling of HSx in case of input supply overvoltage in Stop Mode or Sleep Mode 0 _B ENABLED , shutdown enabled in case of VSHS Overvoltage 1 _B DISABLED , shutdown disabled in case of VSHS Overvoltage
HS_UV_SD_DIS	5	rw	Shutdown Disabling of HSx in case of input supply undervoltage 0 _B ENABLED , shutdown enabled in case of VSHS Undervoltage 1 _B DISABLED , shutdown disabled in case of VSHS Undervoltage
RES	4	r	Reserved, always reads as 0
HS_UV_REC	3	rw	Switch recovery after removal of Undervoltage for HSx 0 _B DISABLED , Switch recovery is disabled 1 _B PREVIOUS , Previous state before VSHS Undervoltage is enabled after Undervoltage condision is removed
RES	2:0	r	Reserved, always reads as 0

Serial Peripheral Interface

Table 50 Reset of **SW_SD_CTRL**

Register Reset Type	Reset Values	Reset Short Name	Reset Mode	Note
POR/Soft reset	0000 0000 0000 0000 _B			
Restart	xxxx xxxx xxx0 x000 _B			

Serial Peripheral Interface

High-Side Switch Control

HS_CTRL

High-Side Switch Control

(000 1000_B)

Reset Value: see [Table 51](#)

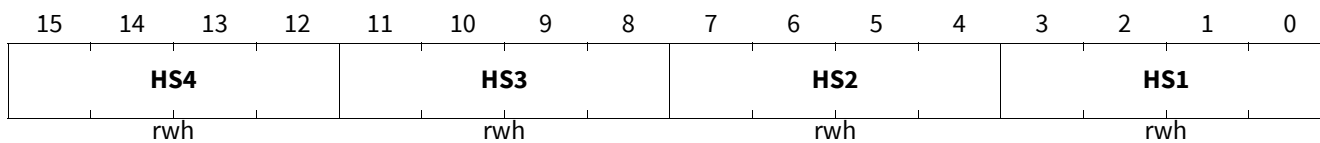

Field	Bits	Type	Description
HS4	15:12	rwh	HS4 Configuration 0000 _B OFF , OFF 0001 _B ON , ON 0010 _B TIMER1 , Controlled by Timer1 0011 _B TIMER2 , Controlled by Timer2 0100 _B PWM1 , Controlled by PWM1 0101 _B PWM2 , Controlled by PWM2 0110 _B PWM3 , Controlled by PWM3 0111 _B PWM4 , Controlled by PWM4 1000 _B WK4_SYNC , Synchronized with WK4/SYNC 1001 _B , reserved 1010 _B , reserved 1011 _B , reserved 1100 _B , reserved 1101 _B , reserved 1110 _B , reserved 1111 _B , reserved
HS3	11:8	rwh	HS3 Configuration 0000 _B OFF , OFF 0001 _B ON , ON 0010 _B TIMER1 , Controlled by Timer1 0011 _B TIMER2 , Controlled by Timer2 0100 _B PWM1 , Controlled by PWM1 0101 _B PWM2 , Controlled by PWM2 0110 _B PWM3 , Controlled by PWM3 0111 _B PWM4 , Controlled by PWM4 1000 _B WK4_SYNC , Synchronized with WK4/SYNC 1001 _B , reserved 1010 _B , reserved 1011 _B , reserved 1100 _B , reserved 1101 _B , reserved 1110 _B , reserved 1111 _B , reserved

Serial Peripheral Interface

Field	Bits	Type	Description
HS2	7:4	rwh	HS2 Configuration 0000 _B OFF , OFF 0001 _B ON , ON 0010 _B TIMER1 , Controlled by Timer1 0011 _B TIMER2 , Controlled by Timer2 0100 _B PWM1 , Controlled by PWM1 0101 _B PWM2 , Controlled by PWM2 0110 _B PWM3 , Controlled by PWM3 0111 _B PWM4 , Controlled by PWM4 1000 _B WK4_SYNC , Synchronized with WK4/SYNC 1001 _B , reserved 1010 _B , reserved 1011 _B , reserved 1100 _B , reserved 1101 _B , reserved 1110 _B , reserved 1111 _B , reserved
HS1	3:0	rwh	HS1 Configuration 0000 _B OFF , OFF 0001 _B ON , ON 0010 _B TIMER1 , Controlled by Timer1 0011 _B TIMER2 , Controlled by Timer2 0100 _B PWM1 , Controlled by PWM1 0101 _B PWM2 , Controlled by PWM2 0110 _B PWM3 , Controlled by PWM3 0111 _B PWM4 , Controlled by PWM4 1000 _B WK4_SYNC , Synchronized with WK4/SYNC 1001 _B , reserved 1010 _B , reserved 1011 _B , reserved 1100 _B , reserved 1101 _B , reserved 1110 _B , reserved 1111 _B , reserved

Table 51 Reset of **HS_CTRL**

Register Reset Type	Reset Values	Reset Short Name	Reset Mode	Note
POR/Soft reset	0000 0000 0000 0000 _B			
Restart	0000 0000 0000 0000 _B			

PWMx in this register designates the internal PWM generators for the integrated high-side switches.

Serial Peripheral Interface

Interrupt Mask Control¹⁾

INT_MASK

Interrupt Mask Control

(000 1001_B)

Reset Value: see [Table 52](#)

15	14	13	12	11	10	9	8	7	6	5	4	3	2	1	0
RES							INTN_CYC_EN	WD_SDM_DISABLE	WD_SDM	SPI_CRC_FAIL	BD_STAT	HS_STAT	BUS_STAT	TEMP_STAT	SUPPLY_STAT
r							rw	rw	rw	rw	rw	rw	rw	rw	rw

Field	Bits	Type	Description
RES	15:9	r	Reserved, always reads as 0
INTN_CYC_EN	8	rw	Periodical INTN generation 0 _B DISABLED , no periodical INTN event generated in case of pending interrupts 1 _B ENABLED , periodical INTN event generated in case of pending interrupts
WD_SDM_DISABLE	7	rw	Disable Watchdog in Software Development Mode 0 _B ENABLED , WD is enabled in Software Development Mode 1 _B DISABLED , WD is disabled in Software Development Mode
WD_SDM	6	rw	Watchdog failure in Software Development Mode 0 _B DISABLED , no INTN event generated in case of WD trigger failure in Software Development Mode 1 _B ENABLED , one INTN event is generated in case of WD trigger failure in Software Development Mode
SPI_CRC_FAIL	5	rw	SPI and CRC interrupt generation 0 _B DISABLED , no INTN event generated in case of SPI_FAIL or CRC_FAIL 1 _B ENABLED , one INTN event is generated in case of SPI_FAIL or CRC_FAIL
BD_STAT	4	rw	Bridge Driver Interrupt generation 0 _B DISABLED , no INTN event generated in case BD_STAT (on Status Information Field) is set 1 _B ENABLED , one INTN event generated in case BD_STAT (on Status Information Field) is set
HS_STAT	3	rw	High Side Interrupt generation 0 _B DISABLED , no INTN event generated in case HS_STAT (on Status Information Field) is set 1 _B ENABLED , one INTN event generated in case HS_STAT (on Status Information Field) is set

1) Every event will generate a signal on the INTN pin (when masked accordingly).
Even if the status-bit was already set in the corresponding status-register it can still trigger a signal on the INTN pin.

Serial Peripheral Interface

Field	Bits	Type	Description
BUS_STAT	2	rw	BUS Interrupt generation 0 _B DISABLED , no INTN event generated in case BUS_STAT (on Status Information Field) is set 1 _B ENABLED , one INTN event generated in case BUS_STAT (on Status Information Field) is set
TEMP_STAT	1	rw	Temperature Interrupt generation 0 _B DISABLED , no INTN event generated in case TEMP_STAT (on Status Information Field) is set 1 _B ENABLED , one INTN event generated in case TEMP_STAT (on Status Information Field) is set
SUPPLY_STAT	0	rw	SUPPLY Status Interrupt generation 0 _B DISABLED , no INTN event generated in case SUPPLY_STAT (on Status Information Field) is set 1 _B ENABLED , one INTN event generated in case SUPPLY_STAT (on Status Information Field) is set

Table 52 Reset of **INT_MASK**

Register Reset Type	Reset Values	Reset Short Name	Reset Mode	Note
POR/Soft reset	0000 0001 0100 0000 _B			
Restart	0000 000x xxxx xxxx _B			

Serial Peripheral Interface

PWM Configuration Control

PWM_CTRL

PWM Configuration Control

(000 1010_B)

Reset Value: see [Table 53](#)

15	14	13	12	11	10	9	8	7	6	5	4	3	2	1	0
RES	PWM_FREQ	PWM_DC										RES	PWM_BNK		
r	rw	rw										r	rw		

Field	Bits	Type	Description
RES	15	r	Reserved, always reads as 0
PWM_FREQ	14	rw	PWM generator Frequency Setting 0 _B 100Hz, 100Hz is selected 1 _B 200Hz, 200Hz is selected
PWM_DC	13:4	rw	PWM Duty Cycle Setting (bit4 = LSB; bit13 = MSB) 00 0000 0000 _B , 100% OFF, i.e. HS = OFF xx xxxx xxxx _B , ON with duty cycle fraction of 1024 11 1111 1111 _B , 100% ON, i.e. HS = ON
RES	3	r	Reserved, always reads as 0
PWM_BNK	2:0	rw	Internal PWM generator selection 000 _B PWM1, PWM1 Module 001 _B PWM2, PWM2 Module 010 _B PWM3, PWM3 Module 011 _B PWM4, PWM4 Module 1xx _B , Don't care

Table 53 Reset of PWM_CTRL

Register Reset Type	Reset Values	Reset Short Name	Reset Mode	Note
POR/Soft reset	0000 0000 0000 0000 _B			
Restart	0xxx xxxx xxxx 0000 _B			

PWMx in this register designates the internal PWM generators for the integrated high-side switches.

Notes

- 0% and 100% duty cycle settings are used to have the switch turned ON or OFF respectively.
- The desired duty cycle should be set first before the HSx is enabled as PWM.
- The PWM signal is correct only after at least one PWM pulse.
- PWM generator accuracy is linked to the oscillator accuracy (see parameter P_13.12.43).

Serial Peripheral Interface

System Status Control

SYS_STAT_CTRL

System Status Control

(000 1011_B)

Reset Value: see [Table 54](#)

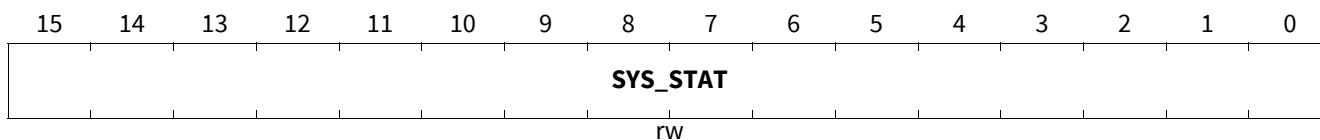

Field	Bits	Type	Description
SYS_STAT	15:0	rw	System Status Control (bit0=LSB; bit15=MSB) Dedicated bytes for system configuration, access only by microcontroller. Cleared after power up and soft reset.

Table 54 Reset of **SYS_STAT_CTRL**

Register Reset Type	Reset Values	Reset Short Name	Reset Mode	Note
POR / Soft reset	0000 0000 0000 0000 _B			
Restart	XXXX XXXX XXXX XXXX _B			

Note: This register is intended for storing system configuration of the ECU by the microcontroller and is only accessible in Normal Mode. The register is not accessible by the TLE9562-3QX and is also not cleared after Fail-Safe or Restart Mode. It allows the microcontroller to quickly store system configuration without losing data.

Serial Peripheral Interface

14.5.2 Control registers bridge driver

General Bridge Control

GENCTRL

General Bridge Control

(001 0000_B)

Reset Value: see [Table 55](#)

15	14	13	12	11	10	9	8	7	6	5	4	3	2	1	0
BDFR EQ	PWM3 4MAP	PWM1 2MAP	CPUV TH	FET_L VL	CPST GA	BDOV _REC	IPCHG ADT	AGC	CPEN	POCH GDIS	AGCFI LT	EN_GE N_CH ECK	IHOLD	FMOD E	
rw	rw	rw	rw	rw	rw	rw	rw	rw	rw	rw	rw	rw	rw	rw	

Field	Bits	Type	Description
BDFREQ	15	rw	Bridge driver synchronization frequency 0 _B 18MHz , typ. 18.75 MHz (default) 1 _B 37MHz , typ. 37.5 MHz
PWM34MAP	14	rw	PWM34MAP 0 _B PWM3_TO_HB3 , PWM3 mapped to HB3 (default) 1 _B PWM3_TO_HB4 , PWM3 mapped to HB4
PWM12MAP	13	rw	PWM12MAP 0 _B PWM1_TO_HB1 , PWM1/CRC mapped to HB1 (default) 1 _B PWM1_TO_HB2 , PWM1/CRC mapped to HB2
CPUVTH	12	rw	Charge pump under voltage (referred to VS) 0 _B TH1 , (default) CPUV threshold 1 for FET_LVL = 0, CPUV threshold 1 for FET_LVL = 1 1 _B TH2 , CPUV threshold 2 for FET_LVL = 0, CPUV threshold 2 for FET_LVL = 1
FET_LVL	11	rw	External MOSFET normal / logic level selection 0 _B LOGIC , Logic level MOSFET selected 1 _B NORMAL , Normal level MOSFET selected(default)
CPSTGA	10	rw	Automatic switchover between dual and single charge pump stage 0 _B INACTIVE , Automatic switch over deactivated (default) 1 _B ACTIVE , Automatic switch over activated
BDOV_REC	9	rw	Bridge driver recover from VS and VSINT Overvoltage 0 _B INACTIVE , Recover deactivated (default) 1 _B ACTIVE , Recover activated
IPCHGADT	8	rw	Adaptation of the pre-charge and pre-discharge current 0 _B 1STEP , 1 current step (default) 1 _B 2STEPS , 2 current steps

Serial Peripheral Interface

Field	Bits	Type	Description
AGC	7:6	rw	Adaptive gate control 00 _B INACTIVE1 , (default) Adaptive gate control disabled, pre-charge and pre-discharge disabled 01 _B INACTIVE2 , Adaptive gate control disabled, precharge is enabled with IPRECHG = IPCHGINIT, predischage is enabled with IPREDCHG = IPDCHGINIT 10 _B ACTIVE , Adaptive gate control enabled, IPRECHG and IPREDCHG are self adapted 11 _B , reserved. Adaptive gate control enabled, IPRECHG and IPREDCHG are self adapted
CPEN	5	rw	CPEN 0 _B DISABLED , Charge pump disabled (default) 1 _B ENABLED , Charge pump enabled
POCHGDIS	4	rw	Postcharge disable bit 0 _B ENABLED , The postcharge phase is enabled during PWM (default) 1 _B DISABLED , The postcharge phase is disabled during PWM
AGCFILT	3	rw	Filter for adaptive gate control 0 _B NO_FILT , No filter applied (default) 1 _B FILT_APPL , Filter applied
EN_GEN_CHECK	2	rw	Detection of active / FW MOSFET 0 _B DISABLED , Detection disabled (default) 1 _B ENABLED , Detection enabled
IHOLD	1	rw	Gate driver hold current IHOLD 0 _B TH1 , (default) Charge: I_{CHG19} , discharge I_{DCHG19} · 1 _B TH2 , Charge: I_{CHG25} , discharge: I_{CHG25}
FMODE	0	rw	Frequency modulation of the charge pump 0 _B NO , No modulation 1 _B 15KHz , Modulation frequency 15.6 kHz (default)

Table 55 Reset of **GENCTRL**

Register Reset Type	Reset Values	Reset Short Name	Reset Mode	Note
POR/Soft reset	0000 1000 0000 0001 _B			
Restart	XXXX XXXX XXXX XXXX _B			

Serial Peripheral Interface

Drain-Source monitoring threshold LS1-4

LS_VDS

VDS monitoring threshold LS1-4

(001 0010_B)

Reset Value: see [Table 56](#)

15	14	13	12	11	10	9	8	7	6	5	4	3	2	1	0
RES		TFVDS		LS4VDSTH			LS3VDSTH			LS2VDSTH		LS1VDSTH			
r		rw		rw			rw			rw		rw			

Field	Bits	Type	Description
RES	15:14	r	Reserved. Always read as 0
TFVDS	13:12	rw	Filter time of drain-source voltage monitoring 00 _B 500ns , 0.5 μs (default) 01 _B 1us , 1 μs 10 _B 2us , 2 μs 11 _B 6us , 6 μs
LS4VDSTH	11:9	rw	LS4 drain-source overvoltage threshold 000 _B 160mV , 0.16 V 001 _B 200mV , 0.20 V (default) 010 _B 300mV , 0.30 V 011 _B 400mV , 0.40 V 100 _B 500mV , 0.50 V 101 _B 600mV , 0.60 V 110 _B 800mV , 0.80 V 111 _B 2V , 2.0 V
LS3VDSTH	8:6	rw	LS3 drain-source overvoltage threshold 000 _B 160mV , 0.16 V 001 _B 200mV , 0.20 V (default) 010 _B 300mV , 0.30 V 011 _B 400mV , 0.40 V 100 _B 500mV , 0.50 V 101 _B 600mV , 0.60 V 110 _B 800mV , 0.80 V 111 _B 2V , 2.0 V
LS2VDSTH	5:3	rw	LS2 drain-source overvoltage threshold 000 _B 160mV , 0.16V 001 _B 200mV , 0.20 V (default) 010 _B 300mV , 0.30 V 011 _B 400mV , 0.40 V 100 _B 500mV , 0.50 V 101 _B 600mV , 0.60 V 110 _B 800mV , 0.80 V 111 _B 2V , 2.0 V

Serial Peripheral Interface

Field	Bits	Type	Description
LS1VDSTH	2:0	rw	LS1 drain-source overvoltage threshold 000 _B 160mV , 0.16 V 001 _B 200mV , 0.20 V (default) 010 _B 300mV , 0.30 V 011 _B 400mV , 0.40 V 100 _B 500mV , 0.50 V 101 _B 600mV , 0.60 V 110 _B 800mV , 0.80 V 111 _B 2V , 2.0 V

Table 56 Reset of **LS_VDS**

Register Reset Type	Reset Values	Reset Short Name	Reset Mode	Note
POR/Soft reset	0000 0010 0100 1001 _B	0000 0000 0000 0000		
Restart	0000 xxxx xxxx xxxx _B			

Serial Peripheral Interface

Drain-Source monitoring Threshold HS1-4

HS_VDS

VDS monitoring threshold HS1-4

(001 0011_B)

Reset Value: see [Table 57](#)

15	14	13	12	11	10	9	8	7	6	5	4	3	2	1	0
RES		RES	DEEP_ADAP	HS4VDSTH			HS3VDSTH			HS2VDSTH			HS1VDSTH		
r		rw		rw			rw			rw			rw		

Field	Bits	Type	Description
RES	15:14	r	Reserved. Always read as 0
RES	13	rw	Reserved. This bit must be programmed to '0'
DEEP_ADAP	12	rw	Deep adaptation enable 0 _B NO_DEEP_ADAP , Deep adaptation disabled (default) 1 _B DEEP_ADAP , Deep adaptation enabled
HS4VDSTH	11:9	rw	HS4 drain-source overvoltage threshold 000 _B 160mV , 0.16 V 001 _B 200mV , 0.20 V (default) 010 _B 300mV , 0.30 V 011 _B 400mV , 0.40 V 100 _B 500mV , 0.50 V 101 _B 600mV , 0.60 V 110 _B 800mV , 0.80 V 111 _B 2V , 2.0 V
HS3VDSTH	8:6	rw	HS3 drain-source overvoltage threshold 000 _B 160mV , 0.16 V 001 _B 200mV , 0.20 V (default) 010 _B 300mV , 0.30 V 011 _B 400mV , 0.40 V 100 _B 500mV , 0.50 V 101 _B 600mV , 0.60 V 110 _B 800mV , 0.80 V 111 _B 2V , 2.0 V
HS2VDSTH	5:3	rw	HS2 drain-source overvoltage threshold 000 _B 160mV , 0.16 V 001 _B 200mV , 0.20 V (default) 010 _B 300mV , 0.30 V 011 _B 400mV , 0.40 V 100 _B 500mV , 0.50 V 101 _B 600mV , 0.60 V 110 _B 800mV , 0.80 V 111 _B 2V , 2.0 V

Serial Peripheral Interface

Field	Bits	Type	Description
HS1VDSTH	2:0	rw	HS1 drain-source overvoltage threshold 000 _B 160mV , 0.16 V 001 _B 200mV , 0.20 V (default) 010 _B 300mV , 0.30 V 011 _B 400mV , 0.40 V 100 _B 500mV , 0.50 V 101 _B 600mV , 0.60 V 110 _B 800mV , 0.80 V 111 _B 2V , 2.0 V

Table 57 Reset of **HS_VDS**

Register Reset Type	Reset Values	Reset Short Name	Reset Mode	Note
POR/Soft reset	0000 0010 0100 1001 _B			
Restart	00xx xxxx xxxx xxxx _B			

Serial Peripheral Interface

CCP and times selection

CCP_BLK

CCP and times selection

(001 0100_B)

Reset Value: see [Table 58](#)

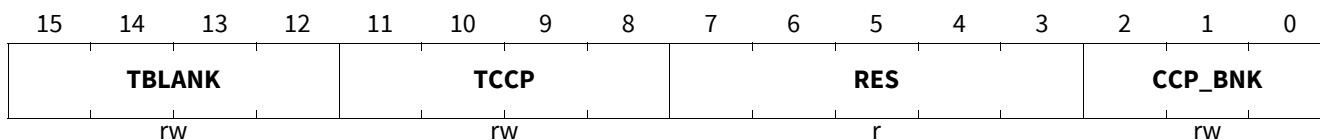

Field	Bits	Type	Description
TBLANK	15:12	rw	Blank time nom. tHBxBLANK = 587 ns + 266 x T[3:0] _D The CCP_BNK bits select the blank time for the FW or active MOSFET and the half-bridge HBx Reset of active and FW tHBxBLANK: 2450 ns typ.
TCCP	11:8	rw	Cross-current protection time nom. tHBxCCP = 587 ns + 266 x TCCP[3:0] _D The CCP_BNK bits select the cross-current protection time for the FW or active MOSFET and the half-bridge HBx Reset of all active and FW tHBxCCP: 2450 ns typ.
RES	7:3	r	Reserved, always reads as 0
CCP_BNK	2:0	rw	Cross-current and time banking 000 _B ACT_HB1 , Active blank and cross-current prot. times for HB1 (default) 001 _B ACT_HB2 , Active blank and cross-current prot. times for HB2 010 _B ACT_HB3 , Active blank and cross-current prot. times for HB3 011 _B ACT_HB4 , Active blank and cross-current prot. times for HB4 100 _B FW_HB1 , FW blank and cross-current prot. times for HB1 101 _B FW_HB2 , FW blank and cross-current prot. times for HB2 110 _B FW_HB3 , FW blank and cross-current prot. for times for HB3 111 _B FW_HB4 , FW blank and cross-current prot. for times for HB4

Table 58 Reset of **CCP_BLK**

Register Reset Type	Reset Values	Reset Short Name	Reset Mode	Note
POR/Soft reset	0111 0111 0000 0000 _B			
Restart	xxxx xxxx 0000 0000 _B			

Serial Peripheral Interface

Half-Bridge MODE

HBMODE

Half-Bridge MODE

(001 0101_B)

Reset Value: see [Table 59](#)

15	14	13	12	11	10	9	8	7	6	5	4	3	2	1	0
HB4MODE	AFW4	HB4_PWM_EN	HB3MODE	AFW3	HB3_PWM_EN	HB2MODE	AFW2	HB2_PWM_EN	HB1MODE	AFW1	HB1_PWM_EN				
rw	rw	rw	rw	rw	rw	rw	rw	rw	rw	rw	rw	rw	rw	rw	rw

Field	Bits	Type	Description
HB4MODE	15:14	rw	Half-bridge 4 MODE selection 00 _B PASSIVE_OFF , LS4 and HS4 are off by passive discharge (default) 01 _B LS4_ON , LS4 is ON 10 _B HS4_ON , HS4 is ON 11 _B ACTIVE_OFF , LS4 and HS4 kept off by the active discharge
AFW4	13	rw	Active freewheeling for half-bridge 4 during PWM 0 _B DISABLED , active freewheeling disabled 1 _B ENABLED , active freewheeling enabled (default)
HB4_PWM_EN	12	rw	PWM mode for half-bridge 4 if PWM34MAP = 1¹⁾ 0 _B INACTIVE , PWM deactivated for HB4(default) 1 _B ACTIVE , PWM activated for HB4
HB3MODE	11:10	rw	Half-bridge 3 MODE selection 00 _B PASSIVE_OFF , LS3 and HS3 are off by passive discharge (default) 01 _B LS3_ON , LS3 is ON 10 _B HS3_ON , HS3 is ON 11 _B ACTIVE_OFF , LS3 and HS3 kept off by the active discharge
AFW3	9	rw	Active freewheeling for half-bridge 3 during PWM 0 _B DISABLED , active freewheeling disabled 1 _B ENABLED , active freewheeling enabled (default)
HB3_PWM_EN	8	rw	PWM mode for half-bridge 3 if PWM34MAP=0²⁾ 0 _B INACTIVE , PWM deactivated for HB2(default) 1 _B ACTIVE , PWM activated for HB2
HB2MODE	7:6	rw	Half-bridge 2 MODE selection 00 _B PASSIVE_OFF , LS2 and HS2 are off by passive discharge (default) 01 _B LS2_ON , LS2 is ON 10 _B HS2_ON , HS2 is ON 11 _B ACTIVE_OFF , LS2 and HS2 kept off by the active discharge

Serial Peripheral Interface

Field	Bits	Type	Description
AFW2	5	rw	Active freewheeling for half-bridge 2 during PWM 0 _B DISABLED , active freewheeling disabled 1 _B ENABLED , active freewheeling enabled (default)
HB2_PWM_EN	4	rw	PWM mode for half-bridge 2 if PWM12MAP = 1³⁾ 0 _B INACTIVE , PWM deactivated for HB2(default) 1 _B ACTIVE , PWM activated for HB2
HB1MODE	3:2	rw	Half-bridge 1 MODE selection 00 _B PASSIVE_OFF , LS1 and HS1 are off by passive discharge (default) 01 _B LS1_ON , LS1 is ON 10 _B HS1_ON , HS1 is ON 11 _B ACTIVE_OFF , LS1 and HS1 kept off by the active discharge
AFW1	1	rw	Active freewheeling for half-bridge 1 during PWM 0 _B DISABLED , active freewheeling disabled 1 _B ENABLED , active freewheeling enabled (default)
HB1_PWM_EN	0	rw	PWM mode for half-bridge 1 if PWM12MAP=0⁴⁾ 0 _B INACTIVE , PWM deactivated for HB1 (default) 1 _B ACTIVE , PWM activated for HB1

- 1) If PWM34MAP = 0, HB4 is controlled statically according to HB4MODE independently from HB4_PWM_EN.
- 2) If PWM34MAP = 1, HB3 is controlled statically according to HB3MODE independently from HB3_PWM_EN.
- 3) If PWM12MAP = 0, HB2 is controlled statically according to HB2MODE independently from HB2_PWM_EN.
- 4) If PWM12MAP = 1, HB1 is controlled statically according to HB1MODE independently from HB1_PWM_EN.

Table 59 Reset of HBMODE

Register Reset Type	Reset Values	Reset Short Name	Reset Mode	Note
POR/Soft reset	0010 0010 0010 0010 _B			
Restart	0010 0010 0010 0010 _B			

Serial Peripheral Interface

HB pre-charge and pre-discharge time

TPRECHG

HB pre-charge and pre-discharge time (001 0110_B) Reset Value: see Table 60

15	14	13	12	11	10	9	8	7	6	5	4	3	2	1	0
TPCHG4				TPCHG3			TPCHG2			TPCHG1		RES	TPCHG_BNK		
rw				rw			rw			rw		r	rw		

Field	Bits	Type	Description
TPCHG4	15:13	rw	<p>If TPCHG_BNK=0: precharge time of HB 4, If TPCHG_BNK=1: pre-discharge time of HB 4</p> <p>000_B 107ns, $t_{PCHG000} / t_{PDCHG000}$ (default) 001_B 160ns, $t_{PCHG001} / t_{PDCHG001}$ 010_B 214ns, $t_{PCHG010} / t_{PDCHG010}$ 011_B 267ns, $t_{PCHG011} / t_{PDCHG011}$ 100_B 320ns, $t_{PCHG100} / t_{PDCHG100}$ 101_B 533ns, $t_{PCHG101} / t_{PDCHG101}$ 110_B 747ns, $t_{PCHG110} / t_{PDCHG110}$ 111_B 1067ns, $t_{PCHG111} / t_{PDCHG111}$</p>
TPCHG3	12:10	rw	<p>If TPCHG_BNK=0: precharge time of HB 3, If TPCHG_BNK=1: pre-discharge time of HB 3</p> <p>000_B 107ns, $t_{PCHG000} / t_{PDCHG000}$ (default) 001_B 160ns, $t_{PCHG001} / t_{PDCHG001}$ 010_B 214ns, $t_{PCHG010} / t_{PDCHG010}$ 011_B 267ns, $t_{PCHG011} / t_{PDCHG011}$ 100_B 320ns, $t_{PCHG100} / t_{PDCHG100}$ 101_B 533ns, $t_{PCHG101} / t_{PDCHG101}$ 110_B 747ns, $t_{PCHG110} / t_{PDCHG110}$ 111_B 1067ns, $t_{PCHG111} / t_{PDCHG111}$</p>
TPCHG2	9:7	rw	<p>If TPCHG_BNK=0: precharge time of HB 2, If TPCHG_BNK=1: pre-discharge time of HB 2</p> <p>000_B 107ns, $t_{PCHG000} / t_{PDCHG000}$ (default) 001_B 160ns, $t_{PCHG001} / t_{PDCHG001}$ 010_B 214ns, $t_{PCHG010} / t_{PDCHG010}$ 011_B 267ns, $t_{PCHG011} / t_{PDCHG011}$ 100_B 320ns, $t_{PCHG100} / t_{PDCHG100}$ 101_B 533ns, $t_{PCHG101} / t_{PDCHG101}$ 110_B 747ns, $t_{PCHG110} / t_{PDCHG110}$ 111_B 1067ns, $t_{PCHG111} / t_{PDCHG111}$</p>

Serial Peripheral Interface

Field	Bits	Type	Description
TPCHG1	6:4	rw	If TPCHG_BNK=0: precharge time of HB 1, If TPCHG_BNK=1: predischage time of HB 1 000 _B 107ns , $t_{PCHG000} / t_{PDCHG000}$ (default) 001 _B 160ns , $t_{PCHG001} / t_{PDCHG001}$ 010 _B 214ns , $t_{PCHG010} / t_{PDCHG010}$ 011 _B 267ns , $t_{PCHG011} / t_{PDCHG011}$ 100 _B 320ns , $t_{PCHG100} / t_{PDCHG100}$ 101 _B 533ns , $t_{PCHG101} / t_{PDCHG101}$ 110 _B 747ns , $t_{PCHG110} / t_{PDCHG110}$ 111 _B 1067ns , $t_{PCHG111} / t_{PDCHG111}$
RES	3	r	Reserved, always read as 0
TPCHG_BNK	2:0	rw	Precharge/predischage time selection 000 _B PRECHARGE , Precharge time selected (default) 001 _B PREDISCHARGE , Predischage time selected x1x _B , wrong setting of TPCHG_BNK 1xx _B , wrong setting of TPCHG_BNK

Table 60 Reset of **TPRECHG**

Register Reset Type	Reset Values	Reset Short Name	Reset Mode	Note
POR/Soft reset	0000 0000 0000 0000 _B			
Restart	xxxx xxxx xxxx 0000 _B			

Serial Peripheral Interface

Static charge/discharge current

ST_ICHG

Static charge/discharge current

(001 0111_B)

Reset Value: see [Table 61](#)

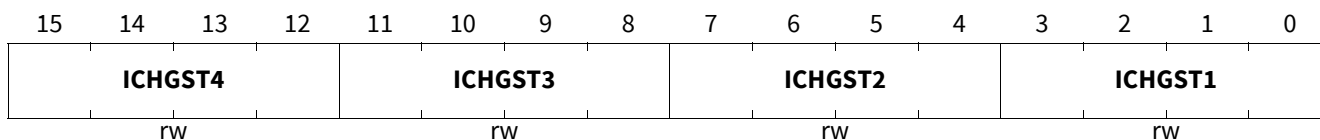

Field	Bits	Type	Description
ICHGST4	15:12	rw	Static charge and discharge currents of HB4 Refer to Table 29 Default: 0100 _B - charge: I_{CHG16} , 9.2 mA typ., discharge I_{DCHG16} , 9.2 mA typ.
ICHGST3	11:8	rw	Static charge and discharge currents of HB3 Refer to Table 29 Default: 0100 _B - charge: I_{CHG16} , 9.2 mA typ., discharge: I_{DCHG16} , 9.2 mA typ.
ICHGST2	7:4	rw	Static charge and discharge currents of HB2 Refer to Table 29 Default: 0100 _B - charge: I_{CHG16} , 9.2 mA typ., discharge I_{DCHG16} , 9.2 mA typ.
ICHGST1	3:0	rw	Static charge and discharge currents of HB1 Refer to Table 29 Default: 0100 _B - charge: I_{CHG16} , 9.2 mA typ., discharge I_{DCHG16} , 9.2 mA typ.

Table 61 Reset of [ST_ICHG](#)

Register Reset Type	Reset Values	Reset Short Name	Reset Mode	Note
POR/Soft reset	0100 0100 0100 0100 _B			
Restart	XXXX XXXX XXXX XXXX _B			

Serial Peripheral Interface

HB charge/discharge currents for PWM operation

HB_ICHG

HB charge/discharge currents for PWM operation

(001 1000_B)

Reset Value: see [Table 62](#)

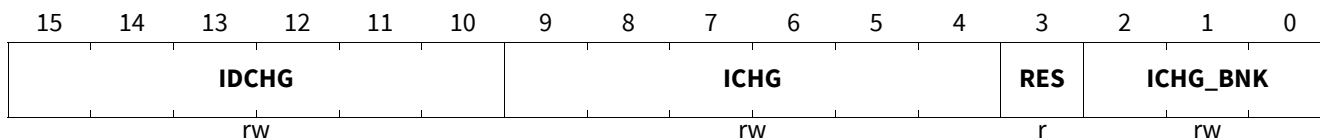

Field	Bits	Type	Description
IDCHG	15:10	rw	<p>If ICHG_BNK=0xx_B: Discharge current of HBx active MOSFET</p> <p>If ICHG_BNK=1xx_B: Reserved. Always read as '0'</p> <p>Default value for all active MOSFETs discharge currents: 001111_B, I_{DCHG15}</p> <p>Refer to Table 32 for the configuration of the discharge current</p>
ICHG	9:4	rw	<p>If ICHG_BNK=0xx_B: Charge current of HBx active MOSFET</p> <p>If ICHG_BNK=1xx_B: Charge and discharge current of HBx FW MOSFETs</p> <p>Default value for all active MOSFETs charge currents and all FW MOSFETs charge/discharge currents: 001101_B, I_{CHG13}</p> <p>Refer to Table 31 for the configuration of the charge current of the active and FW MOSFET</p> <p>Refer to Table 32 for the configuration of the discharge current of the FW MOSFET</p>
RES	3	r	Reserved, always read as 0
ICHG_BNK	2:0	rw	<p>Banking bits for charge and discharge currents of active MOSFETs</p> <p>000_B ACT_HB1, Active MOSFET of HB1 is selected (default)</p> <p>001_B ACT_HB2, Active MOSFET of HB2 is selected</p> <p>010_B ACT_HB3, Active MOSFET of HB3 is selected</p> <p>011_B ACT_HB4, Active MOSFET of HB4 is selected</p> <p>100_B FW_HB1, FW MOSFET of HB1 is selected</p> <p>101_B FW_HB2, FW MOSFET of HB2 is selected</p> <p>110_B FW_HB3, FW MOSFET of HB3 is selected</p> <p>111_B FW_HB4, FW MOSFET of HB4 is selected</p>

Table 62 Reset of **HB_ICHG**

Register Reset Type	Reset Values	Reset Short Name	Reset Mode	Note
POR/Soft reset	0011 1100 1101 0000 _B			POR value valid for ICHG_BNK = 0
Restart	xxxx xxxx xxxx 0000 _B			

Serial Peripheral Interface

HB max. pre-charge/pre-discharge in PWM operation current and diagnostic pull-down

HB_ICHG_MAX

HB max. pre-charge/pre-discharge in PWM operation current and diagnostic pull-down

(001 1001_B)

Reset Value: see [Table 63](#)

15	14	13	12	11	10	9	8	7	6	5	4	3	2	1	0
HB4ID IAG	HB3ID IAG	HB2ID IAG	HB1ID IAG	RES				ICHGMAX4		ICHGMAX3		ICHGMAX2		ICHGMAX1	
rw	rw	rw	rw	r				rw		rw		rw		rw	

Field	Bits	Type	Description
HB4IDIAG	15	rw	Control of HB4 off-state current source and current sink 0 _B INACTIVE , Pull-down deactivated (default) 1 _B ACTIVE , Pull-down activated
HB3IDIAG	14	rw	Control of HB3 off-state current source and current sink 0 _B INACTIVE , Pull-down deactivated (default) 1 _B ACTIVE , Pull-down activated
HB2IDIAG	13	rw	Control of HB2 pull-down for off-state diagnostic 0 _B INACTIVE , Pull-down deactivated (default) 1 _B ACTIVE , Pull-down activated
HB1IDIAG	12	rw	Control of HB1 pull-down for off-state diagnostic 0 _B INACTIVE , Pull-down deactivated (default) 1 _B ACTIVE , Pull-down activated
RES	11:8	r	Reserved, always read as 0
ICHGMAX4	7:6	rw	Maximum drive current of HB4 during the pre-charge phase and pre-discharge phases¹⁾ 00 _B 19mA , charge I _{CHG24} : typ. 19.2 mA, discharge I _{DCHG24} : typ. 18.8 mA (default) 01 _B 32mA , charge I _{CHG32} : typ. 32.8 mA, discharge I _{DCHG32} : typ. 32.2 mA 10 _B 73mA , charge I _{CHG52} : typ. 73.2 mA, discharge I _{DCHG52} : typ. 72.4mA 11 _B 100mA , charge I _{CHG63} : typ. 100 mA, discharge I _{DCHG63} : typ. 100 mA
ICHGMAX3	5:4	rw	Maximum drive current of HB3 during the pre-charge and pre-discharge phases¹⁾ 00 _B 19mA , charge I _{CHG24} : typ. 19.2 mA, discharge I _{DCHG24} : typ. 18.8 mA (default) 01 _B 32mA , charge I _{CHG32} : typ. 32.8 mA, discharge I _{DCHG32} : typ. 32.2 mA 10 _B 73mA , charge I _{CHG52} : typ. 73.2 mA, discharge I _{DCHG52} : typ. 72.4mA 11 _B 100mA , charge I _{CHG63} : typ. 100 mA, discharge I _{DCHG63} : typ. 100 mA

Serial Peripheral Interface

Field	Bits	Type	Description
ICHGMAX2	3:2	rw	<p>Maximum drive current of HB2 during the pre-charge phase and pre-discharge phases¹⁾</p> <p>00_B 19mA, charge I_{CHG24}: typ. 19.2 mA, discharge I_{DCHG24}: typ. 18.8 mA (default)</p> <p>01_B 32mA, charge I_{CHG32}: typ. 32.8 mA, discharge I_{DCHG32}: typ. 32.2 mA</p> <p>10_B 73mA, charge I_{CHG52}: typ. 73.2 mA, discharge I_{DCHG52}: typ. 72.4mA</p> <p>11_B 100mA, charge I_{CHG63}: typ. 100 mA, discharge I_{DCHG63}: typ. 100 mA</p>
ICHGMAX1	1:0	rw	<p>Maximum drive current of HB1 during the pre-charge and pre-discharge phases¹⁾</p> <p>00_B 19mA, charge I_{CHG24}: typ. 19.2 mA, discharge I_{DCHG24}: typ. 18.8 mA (default)</p> <p>01_B 32mA, charge I_{CHG32}: typ. 32.8 mA, discharge I_{DCHG32}: typ. 32.2 mA</p> <p>10_B 73mA, charge I_{CHG52}: typ. 73.2 mA, discharge I_{DCHG52}: typ. 72.4mA</p> <p>11_B 100mA, charge I_{CHG63}: typ. 100 mA, discharge I_{DCHG63}: typ. 100 mA</p>

1) ICHGMAX is also the current applied during the post-charge of the PWM MOSFET.

Table 63 Reset of **HB_ICHG_MAX**

Register Reset Type	Reset Values	Reset Short Name	Reset Mode	Note
POR/Soft reset	0000 0000 0000 0000 _B			
Restart	xxxx 0000 xxxx xxxx _B			

Serial Peripheral Interface

HBx pre-charge/pre-discharge initialization configuration in PWM operation

HB_PCHG_INIT

HBx pre-charge/pre-discharge initialization configuration in PWM operation

(001 1010_B)

Reset Value: see [Table 64](#)

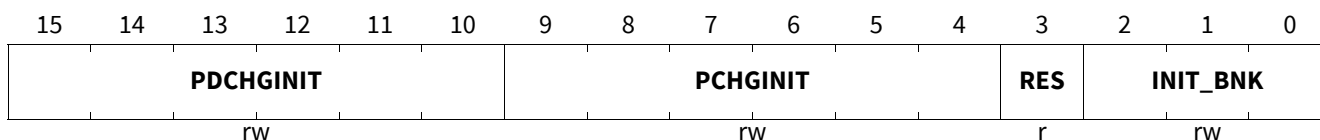

Field	Bits	Type	Description
PDCHGINIT	15:10	rw	Initial predischARGE current of HBx, IPDCHGINITx The INIT_BNK bits select the addressed half-bridge Default: 001111 _B Refer to Table 32
PCHGINIT	9:4	rw	Initial precharge current of HBx, IPCHGINITx The INIT_BNK bits select the addressed half-bridge Default: 001101 _B Refer to Table 31
RES	3	r	Reserved, always reads as 0
INIT_BNK	2:0	rw	Banking bits for Precharge an PredischARGE Initial Current 000 _B HB1 , precharge/dischARGE init. for HB1 selected (default) 001 _B HB2 , precharge/dischARGE init. for HB2 selected 010 _B HB3 , precharge/dischARGE init. for HB3 selected 011 _B HB4 , precharge/dischARGE init. for HB4 selected 1xx _B , wrong setting of INIT_BANK

Table 64 Reset of [HB_PCHG_INIT](#)

Register	Reset Type	Reset Values	Reset Short Name	Reset Mode	Note
POR/Soft reset		0011 1100 1101 0000 _B			
Restart		xxxx xxxx xxxx 0000 _B			

Serial Peripheral Interface

HBx inputs TDON configuration

TDON_HB_CTRL

HBx inputs TDON configuration

(001 1011_B)

Reset Value: see [Table 65](#)

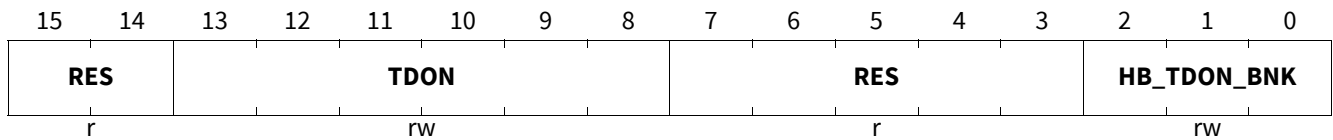

Field	Bits	Type	Description
RES	15:14	r	Reserved, always read as 0
TDON	13:8	rw	Turn-on delay time of active MOSFET of HBx The HB_TDON_BNK bits selects the turn-on delay time of the active MOSFET of the half-bridge HBx Nominal tDON = 53.3 ns x TDON[5:0] _D Default: 00 1100 _B : 640 ns typ.
RES	7:3	r	Reserved, always read as 0
HB_TDON_BNK	2:0	rw	Banking bits for turn-on delay time 000 _B HB1 , tDON of HB1 selected (default) 001 _B HB2 , tDON of HB2 selected 010 _B HB3 , tDON of HB3 selected 011 _B HB4 , tDON of HB4 selected 1xx _B , wrong setting of PWM_TDON_BNK

Table 65 Reset of **TDON_HB_CTRL**

Register Reset Type	Reset Values	Reset Short Name	Reset Mode	Note
POR/Soft reset	0000 1100 0000 0000 _B			
Restart	00xx xxxx 0000 0000 _B			

Serial Peripheral Interface

HBx TDOFF configuration

TDOFF_HB_CTRL

HBx TDOFF configuration

(001 1100_B)

Reset Value: see [Table 66](#)

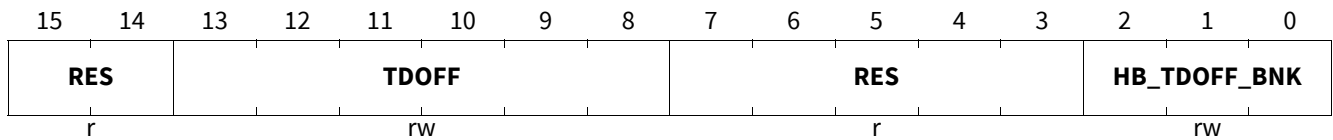

Field	Bits	Type	Description
RES	15:14	r	Reserved, always read as 0
TDOFF	13:8	rw	Turn-off delay time of active MOSFET of HBx The HB_TDOFF_BNK bits selects the turn-off delay time of the active MOSFET of the half-bridge HBx Nominal tDOFF = 53.3 ns x TDOFF[5:0] _D Default: 0000 1100 _B : 640 ns
RES	7:3	r	Reserved, always read as 0
HB_TDOFF_BNK	2:0	rw	Banking bits for turn-off delay time 000 _B HB1 , tDOFF of HB1 selected (default) 001 _B HB2 , tDOFF of HB2 selected 010 _B HB3 , tDOFF of HB3 selected 011 _B HB4 , tDOFF of HB4 selected 1xx _B , wrong setting of PWM_TDOFF_BNK

Table 66 Reset of **TDOFF_HB_CTRL**

Register Reset Type	Reset Values	Reset Short Name	Reset Mode	Note
POR/Soft reset	0000 1100 0000 0000 _B			
Restart	00xx xxxx 0000 0000 _B			

Serial Peripheral Interface

Brake control

BRAKE

Brake control

(001 1101_B)

Reset Value: see [Table 67](#)

15	14	13	12	11	10	9	8	7	6	5	4	3	2	1	0
RES	SLAM_LS4_DIS	SLAM_LS3_DIS	SLAM_LS2_DIS	SLAM_LS1_DIS	SLAM	VDSTH_BRK	TBLK_BRK	PARK_BRK_EN	OV_BRK_EN	RES	OV_BRK_TH				
r	rw	rw	rw	rw	rw	rw	rw	rw	rw	rw	rw				

Field	Bits	Type	Description
RES	15:14	r	Reserved, always read as 0
SLAM_LS4_DIS	13	rw	LS4 output disable during SLAM mode 0 _B ACTIVE, LS4 control active in Slam mode (default) 1 _B DISABLED, LS4 control disabled in Slam mode
SLAM_LS3_DIS	12	rw	LS3 output disable during SLAM mode 0 _B ACTIVE, LS3 control active in Slam mode (default) 1 _B DISABLED, LS3 control disabled in Slam mode
SLAM_LS2_DIS	11	rw	LS2 output disable during SLAM mode 0 _B ACTIVE, LS2 control active in Slam mode (default) 1 _B DISABLED, LS2 control disabled in Slam mode
SLAM_LS1_DIS	10	rw	LS1 output disable during SLAM mode 0 _B ACTIVE, LS1 control active in Slam mode (default) 1 _B DISABLED, LS1 control disabled in Slam mode
SLAM	9	rw	Slam mode 0 _B INACTIVE, Slam mode deactivated (default) 1 _B ACTIVE, Slam mode activated
VDSTH_BRK	8	rw	VDS Overvoltage for LS1-4 during braking 0 _B 800mV, $V_{VDSMONTH0_BRAKE}$: 0.8 V, typ. (default) 1 _B 220mV, $V_{VDSMONTH1_BRAKE}$: 0.22 V typ.
TBLK_BRK	7	rw	Blank time of VDS overvoltage during braking 0 _B 7 μ S, t_{BLK_BRAKE1} : 7 μ S typ. 1 _B 11 μ S, t_{BLK_BRAKE2} : 11 μ S typ. (default)
PARK_BRK_EN	6	rw	Parking brake enable 0 _B DISABLED, Parking brake disabled (default) 1 _B ENABLED, Parking brake enabled
OV_BRK_EN	5	rw	Overvoltage brake enable 0 _B DISABLED, Overvoltage brake disabled 1 _B ENABLED, Overvoltage brake enabled (default)
RES	4:3	rw	Reserved, to be set to 0

Serial Peripheral Interface

Field	Bits	Type	Description
OV_BRK_TH	2:0	rw	Overvoltage brake threshold 000 _B 27V , typ. 27V (default) 001 _B 28V , typ. 28V 010 _B 29V , typ. 29V 011 _B 30V , typ. 30V 100 _B 31V , typ. 31V 101 _B 32V , typ. 32V 110 _B 33V , typ. 33V 111 _B 34V , typ. 34V

Table 67 Reset of **BRAKE**

Register Reset Type	Reset Values	Reset Short Name	Reset Mode	Note
POR/Soft reset	0000 0000 1010 0000 _B			
Restart	00xx xxxx xxx0 0xxx _B			

Note: For min and max values of **OV_BRK_TH**, refer to [Chapter 13.12](#).

Serial Peripheral Interface

14.5.3 Selective Wake Registers

CAN Selective Wake Control

SWK_CTRL

CAN Selective Wake Control

(011 0000_B)

Reset Value: see [Table 68](#)

15	14	13	12	11	10	9	8	7	6	5	4	3	2	1	0
RES								OSC_CAL	TRIM_EN	CANTO_MASK	RES			CFG_VAL	
r								rw	rw	rw	r			rwh	

Field	Bits	Type	Description
RES	15:8	r	Reserved, always reads as 0
OSC_CAL	7	rw	Oscillator Calibration Mode 0 _B DISABLED , Oscillator Calibration is disabled 1 _B ENABLED , Oscillator Calibration is enabled
TRIM_EN	6:5	rw	(Un)locking mechanism of oscillator recalibration 00 _B LOCKED , locked 01 _B LOCKED , locked 10 _B LOCKED , locked 11 _B UNLOCKED , unlocked
CANTO_MASK	4	rw	CAN Time Out Masking 0 _B MASKED , CAN time-out is masked - no interrupt (on pin INTN) is triggered 1 _B UNMASKED , CAN time-out is signaled on INTN
RES	3:1	r	Reserved, always reads as 0
CFG_VAL	0	rwh	SWK Configuration valid 0 _B NOT_VALID , Configuration is not valid (SWK not possible) 1 _B VALID , SWK configuration valid, needs to be set to enable SWK

Table 68 Reset of [SWK_CTRL](#)

Register Reset Type	Reset Values	Reset Short Name	Reset Mode	Note
POR/Soft reset	0000 0000 0000 0000 _B			
Restart	0000 0000 xxxx 0000 _B			

Notes

1. TRIM_EN unlocks the oscillation calibration mode. Only the bit combination '11' is the valid unlock. The pin TXDCAN is used for oscillator synchronisation (trimming).
2. The microcontroller needs to validate the SWK configuration and set 'CFG_VAL' to '1'. The device will only enable SWK if 'CFG_VAL' to '1'. The bit will be cleared automatically by the device after a wake up or POR or if a SWK configuration data is changed by the microcontroller.

Serial Peripheral Interface

3. *CANTO bit will only be updated inside BUS_STAT while CAN_2 is set. Therefore, an interrupt is only signaled upon occurrence of CANTO while CAN_2 (SWK is enabled) is set in Normal Mode and Stop Mode.*

SWK Bit Timing Control

SWK_BTL1_CTRL

SWK Bit Timing Control

(011 0001_B)

Reset Value: see Table 69

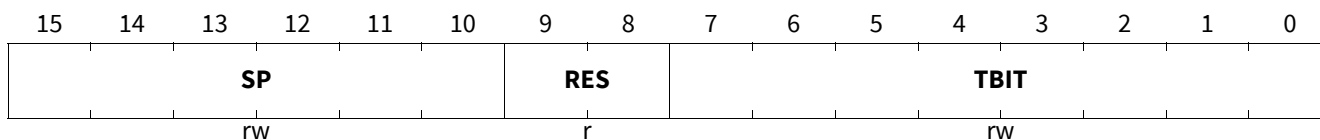

Field	Bits	Type	Description
SP	15:10	rw	Sampling Point Position Represents the sampling point position (fractional number < 1). Example: 0011 0011 = 0.796875 (~80%)
RES	9:8	r	Reserved, always reads as 0
TBIT	7:0	rw	Number of Time Quanta in a Bit Time Represents the number of time quanta in a bit time. Quanta is depending on x<1:0> from the x register.

Table 69 Reset of SWK_BTL1_CTRL

Register Reset Type	Reset Values	Reset Short Name	Reset Mode	Note
POR/Soft reset	1100 1100 1001 0110 _B			
Restart	xxxx xx00 xxxx xxxx _B			

Serial Peripheral Interface

SWK WUF Identifier bits

SWK_ID1_CTRL

SWK WUF Identifier bits 28...13

(011 0010_B)

Reset Value: see [Table 70](#)

15	14	13	12	11	10	9	8	7	6	5	4	3	2	1	0
ID28	ID27	ID26	ID25	ID24	ID23	ID22	ID21	ID20	ID19	ID18	ID17	ID16	ID15	ID14	ID13
rw	rw	rw	rw	rw	rw	rw	rw	rw	rw	rw	rw	rw	rw	rw	rw

Field	Bits	Type	Description
ID28	15	rw	WUF Identifier Bit 28
ID27	14	rw	WUF Identifier Bit 27
ID26	13	rw	WUF Identifier Bit 26
ID25	12	rw	WUF Identifier Bit 25
ID24	11	rw	WUF Identifier Bit 24
ID23	10	rw	WUF Identifier Bit 23
ID22	9	rw	WUF Identifier Bit 22
ID21	8	rw	WUF Identifier Bit 21
ID20	7	rw	WUF Identifier Bit 20
ID19	6	rw	WUF Identifier Bit 19
ID18	5	rw	WUF Identifier Bit 18
ID17	4	rw	WUF Identifier Bit 17
ID16	3	rw	WUF Identifier Bit 16
ID15	2	rw	WUF Identifier Bit 15
ID14	1	rw	WUF Identifier Bit 14
ID13	0	rw	WUF Identifier Bit 13

Table 70 Reset of SWK_ID1_CTRL

Register Reset Type	Reset Values	Reset Short Name	Reset Mode	Note
POR/Soft reset	0000 0000 0000 0000 _B			
Restart	XXXX XXXX XXXX XXXX _B			

Serial Peripheral Interface

SWK WUF Identifier bits

SWK_ID0_CTRL

SWK WUF Identifier bits 12...0

(011 0011_B)

Reset Value: see [Table 71](#)

15	14	13	12	11	10	9	8	7	6	5	4	3	2	1	0
ID12	ID11	ID10	ID9	ID8	ID7	ID6	ID5	RES	ID4	ID3	ID2	ID1	ID0	RTR	IDE
rw	rw	rw	rw	rw	rw	rw	rw	r	rw	rw	rw	rw	rw	rw	rw

Field	Bits	Type	Description
ID12	15	rw	WUF Identifier Bit 12
ID11	14	rw	WUF Identifier Bit 11
ID10	13	rw	WUF Identifier Bit 10
ID9	12	rw	WUF Identifier Bit 9
ID8	11	rw	WUF Identifier Bit 8
ID7	10	rw	WUF Identifier Bit 7
ID6	9	rw	WUF Identifier Bit 6
ID5	8	rw	WUF Identifier Bit 5
RES	7	r	Reserved, always reads as 0
ID4	6	rw	WUF Identifier Bit 4
ID3	5	rw	WUF Identifier Bit 3
ID2	4	rw	WUF Identifier Bit 2
ID1	3	rw	WUF Identifier Bit 1
ID0	2	rw	WUF Identifier Bit 0
RTR	1	rw	Remote Transmission Request Field (acc. ISO11898-2:2016) 0 _B NORMAL , Normal Data Frame 1 _B REMOTE , Remote Transmission Request
IDE	0	rw	Identifier Extension Bit 0 _B STD , Standard Identifier Length (11 bit) 1 _B EXT , Extended Identifier Length (29 bit)

Table 71 Reset of **SWK_ID0_CTRL**

Register Reset Type	Reset Values	Reset Short Name	Reset Mode	Note
POR/Soft reset	0000 0000 0000 0000 _B			
Restart	xxxx xxxx 0xxx xxxx _B			

Serial Peripheral Interface

SWK WUF Identifier Mask bits 28...13

SWK_MASK_ID1_CTRL

SWK WUF Identifier Mask bits 28...13

(011 0100_B)

Reset Value: see [Table 72](#)

15	14	13	12	11	10	9	8	7	6	5	4	3	2	1	0
MASK_ID28	MASK_ID27	MASK_ID26	MASK_ID25	MASK_ID24	MASK_ID23	MASK_ID22	MASK_ID21	MASK_ID20	MASK_ID19	MASK_ID18	MASK_ID17	MASK_ID16	MASK_ID15	MASK_ID14	MASK_ID13
rw	rw	rw	rw	rw	rw	rw	rw	rw	rw	rw	rw	rw	rw	rw	rw

Field	Bits	Type	Description
MASK_ID28	15	rw	WUF Identifier Mask Bit 28 0 _B UNMASKED, Unmasked - bit is ignored 1 _B MASKED, Masked - bit is compared in CAN frame
MASK_ID27	14	rw	WUF Identifier Mask Bit 27 0 _B UNMASKED, Unmasked - bit is ignored 1 _B MASKED, Masked - bit is compared in CAN frame
MASK_ID26	13	rw	WUF Identifier Mask Bit 26 0 _B UNMASKED, Unmasked - bit is ignored 1 _B MASKED, Masked - bit is compared in CAN frame
MASK_ID25	12	rw	WUF Identifier Mask Bit 25 0 _B UNMASKED, Unmasked - bit is ignored 1 _B MASKED, Masked - bit is compared in CAN frame
MASK_ID24	11	rw	WUF Identifier Mask Bit 24 0 _B UNMASKED, Unmasked - bit is ignored 1 _B MASKED, Masked - bit is compared in CAN frame
MASK_ID23	10	rw	WUF Identifier Mask Bit 23 0 _B UNMASKED, Unmasked - bit is ignored 1 _B MASKED, Masked - bit is compared in CAN frame
MASK_ID22	9	rw	WUF Identifier Mask Bit 22 0 _B UNMASKED, Unmasked - bit is ignored 1 _B MASKED, Masked - bit is compared in CAN frame
MASK_ID21	8	rw	WUF Identifier Mask Bit 21 0 _B UNMASKED, Unmasked - bit is ignored 1 _B MASKED, Masked - bit is compared in CAN frame
MASK_ID20	7	rw	WUF Identifier Mask Bit 20 0 _B UNMASKED, Unmasked - bit is ignored 1 _B MASKED, Masked - bit is compared in CAN frame
MASK_ID19	6	rw	WUF Identifier Mask Bit 19 0 _B UNMASKED, Unmasked - bit is ignored 1 _B MASKED, Masked - bit is compared in CAN frame
MASK_ID18	5	rw	WUF Identifier Mask Bit 18 0 _B UNMASKED, Unmasked - bit is ignored 1 _B MASKED, Masked - bit is compared in CAN frame

Serial Peripheral Interface

Field	Bits	Type	Description
MASK_ID17	4	rw	WUF Identifier Mask Bit 17 0 _B UNMASKED , Unmasked - bit is ignored 1 _B MASKED , Masked - bit is compared in CAN frame
MASK_ID16	3	rw	WUF Identifier Mask Bit 16 0 _B UNMASKED , Unmasked - bit is ignored 1 _B MASKED , Masked - bit is compared in CAN frame
MASK_ID15	2	rw	WUF Identifier Mask Bit 15 0 _B UNMASKED , Unmasked - bit is ignored 1 _B MASKED , Masked - bit is compared in CAN frame
MASK_ID14	1	rw	WUF Identifier Mask Bit 14 0 _B UNMASKED , Unmasked - bit is ignored 1 _B MASKED , Masked - bit is compared in CAN frame
MASK_ID13	0	rw	WUF Identifier Mask Bit 13 0 _B UNMASKED , Unmasked - bit is ignored 1 _B MASKED , Masked - bit is compared in CAN frame

Table 72 Reset of **SWK_MASK_ID1_CTRL**

Register Reset Type	Reset Values	Reset Short Name	Reset Mode	Note
POR/Soft reset	0000 0000 0000 0000 _B			
Restart	XXXX XXXX XXXX XXXX _B			

Serial Peripheral Interface

SWK WUF Identifier Mask bits 12...0

SWK_MASK_ID0_CTRL

SWK WUF Identifier Mask bits 12...0

(011 0101_B)

Reset Value: see [Table 73](#)

15	14	13	12	11	10	9	8	7	6	5	4	3	2	1	0
MASK_ID12	MASK_ID11	MASK_ID10	MASK_ID9	MASK_ID8	MASK_ID7	MASK_ID6	MASK_ID5	RES	MASK_ID4	MASK_ID3	MASK_ID2	MASK_ID1	MASK_ID0	RES	
rw	rw	rw	rw	rw	rw	rw	rw	r	rw	rw	rw	rw	rw	r	

Field	Bits	Type	Description
MASK_ID12	15	rw	WUF Identifier Mask Bit 12 0 _B UNMASKED, Unmasked - bit is ignored 1 _B MASKED, Masked - bit is compared in CAN frame
MASK_ID11	14	rw	WUF Identifier Mask Bit 11 0 _B UNMASKED, Unmasked - bit is ignored 1 _B MASKED, Masked - bit is compared in CAN frame
MASK_ID10	13	rw	WUF Identifier Mask Bit 10 0 _B UNMASKED, Unmasked - bit is ignored 1 _B MASKED, Masked - bit is compared in CAN frame
MASK_ID9	12	rw	WUF Identifier Mask Bit 9 0 _B UNMASKED, Unmasked - bit is ignored 1 _B MASKED, Masked - bit is compared in CAN frame
MASK_ID8	11	rw	WUF Identifier Mask Bit 8 0 _B UNMASKED, Unmasked - bit is ignored 1 _B MASKED, Masked - bit is compared in CAN frame
MASK_ID7	10	rw	WUF Identifier Mask Bit 7 0 _B UNMASKED, Unmasked - bit is ignored 1 _B MASKED, Masked - bit is compared in CAN frame
MASK_ID6	9	rw	WUF Identifier Mask Bit 6 0 _B UNMASKED, Unmasked - bit is ignored 1 _B MASKED, Masked - bit is compared in CAN frame
MASK_ID5	8	rw	WUF Identifier Mask Bit 5 0 _B UNMASKED, Unmasked - bit is ignored 1 _B MASKED, Masked - bit is compared in CAN frame
RES	7	r	Reserved, always reads as 0
MASK_ID4	6	rw	WUF Identifier Mask Bit 4 0 _B UNMASKED, Unmasked - bit is ignored 1 _B MASKED, Masked - bit is compared in CAN frame
MASK_ID3	5	rw	WUF Identifier Mask Bit 3 0 _B UNMASKED, Unmasked - bit is ignored 1 _B MASKED, Masked - bit is compared in CAN frame
MASK_ID2	4	rw	WUF Identifier Mask Bit 2 0 _B UNMASKED, Unmasked - bit is ignored 1 _B MASKED, Masked - bit is compared in CAN frame

Serial Peripheral Interface

Field	Bits	Type	Description
MASK_ID1	3	rw	WUF Identifier Mask Bit 1 0 _B UNMASKED , Unmasked - bit is ignored 1 _B MASKED , Masked - bit is compared in CAN frame
MASK_ID0	2	rw	WUF Identifier Mask Bit 0 0 _B UNMASKED , Unmasked - bit is ignored 1 _B MASKED , Masked - bit is compared in CAN frame
RES	1:0	r	Reserved, always reads as 0

Table 73 Reset of **SWK_MASK_ID0_CTRL**

Register Reset Type	Reset Values	Reset Short Name	Reset Mode	Note
POR/Soft reset	0000 0000 0000 0000 _B			
Restart	xxxx xxxx 0xxx xx00 _B			

Serial Peripheral Interface

SWK Frame Data Length Code Control

SWK_DLC_CTRL

SWK Frame Data Length Code Control

(011 0110_B)

Reset Value: see [Table 74](#)

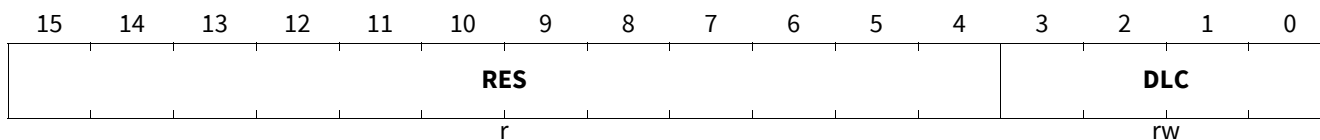

Field	Bits	Type	Description
RES	15:4	r	Reserved, always reads as 0
DLC	3:0	rw	Payload length in number of bytes 0000 _B 0 , Frame Data Length = 0 or cleared 0001 _B 1 , Frame Data Length = 1 0010 _B 2 , Frame Data Length = 2 0011 _B 3 , Frame Data Length = 3 0100 _B 4 , Frame Data Length = 4 0101 _B 5 , Frame Data Length = 5 0110 _B 6 , Frame Data Length = 6 0111 _B 7 , Frame Data Length = 7 1000 _B 8 , to 1111 _B Frame Data Length = 8

Table 74 Reset of [SWK_DLC_CTRL](#)

Register Reset Type	Reset Values	Reset Short Name	Reset Mode	Note
POR/Soft reset	0000 0000 0000 0000 _B			
Restart	0000 0000 0000 xxxx _B			

Note: The number of transmitted bytes in the data field has to be indicated by the DLC. The DLC value consists of four bits. The admissible number of data bytes for a data frame is in a range from zero to eight. DLCs in the range of zero to seven indicates data fields of length of zero to seven bytes. DLCs in the range from eight to fifteen indicate data fields with a length of eight bytes. The configured DLC value has to match bit by bit with the DLC in the received wake-up frame (refer also to [Chapter 5.9.2.2](#)).

Serial Peripheral Interface

SWK Data7-Data6 Register

SWK_DATA3_CTRL

SWK Data7-Data6 Register

(011 0111_B)

Reset Value: see [Table 75](#)

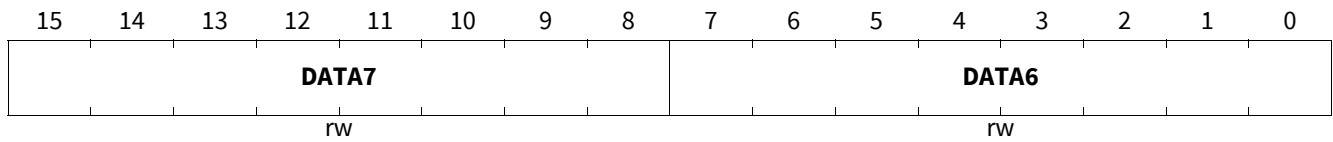

Field	Bits	Type	Description
DATA7	15:8	rw	Data7 byte content(bit0=LSB; bit7=MSB)
DATA6	7:0	rw	Data6 byte content(bit0=LSB; bit7=MSB)

Table 75 Reset of [SWK_DATA3_CTRL](#)

Register Reset Type	Reset Values	Reset Short Name	Reset Mode	Note
POR/Soft reset	0000 0000 0000 0000 _B			
Restart	XXXX XXXX XXXX XXXX _B			

Serial Peripheral Interface

SWK Data5-Data4 Register

SWK_DATA2_CTRL

SWK Data5-Data4 Register

(011 1000_B)

Reset Value: see [Table 76](#)

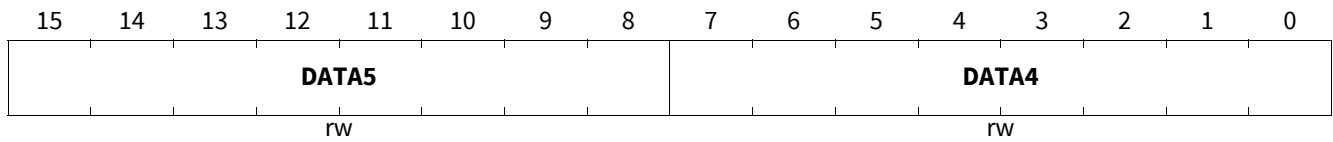

Field	Bits	Type	Description
DATA5	15:8	rw	Data5 byte content(bit0=LSB; bit7=MSB)
DATA4	7:0	rw	Data4 byte content(bit0=LSB; bit7=MSB)

Table 76 Reset of [SWK_DATA2_CTRL](#)

Register Reset Type	Reset Values	Reset Short Name	Reset Mode	Note
POR/Soft reset	0000 0000 0000 0000 _B			
Restart	XXXX XXXX XXXX XXXX _B			

Serial Peripheral Interface

SWK Data3-Data2 Register

SWK_DATA1_CTRL

SWK Data3-Data2 Register

(011 1001_B)

Reset Value: see [Table 77](#)

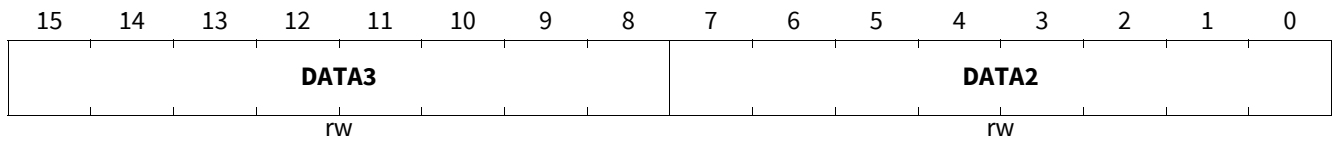

Field	Bits	Type	Description
DATA3	15:8	rw	Data3 byte content(bit0=LSB; bit7=MSB)
DATA2	7:0	rw	Data2 byte content(bit0=LSB; bit7=MSB)

Table 77 Reset of [SWK_DATA1_CTRL](#)

Register Reset Type	Reset Values	Reset Short Name	Reset Mode	Note
POR/Soft reset	0000 0000 0000 0000 _B			
Restart	XXXXX XXXX XXXX XXXX _B			

Serial Peripheral Interface

SWK Data1-Data0 Register

SWK_DATA0_CTRL

SWK Data1-Data0 Register

(011 1010_B)

Reset Value: see [Table 78](#)

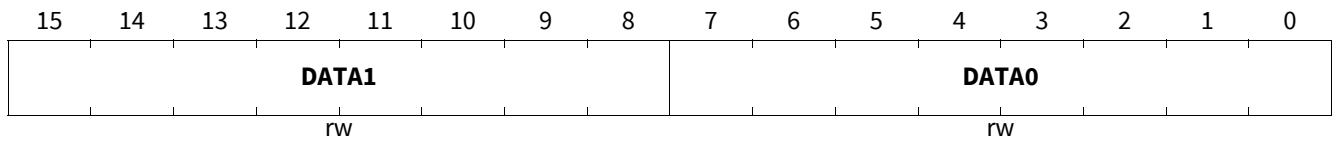

Field	Bits	Type	Description
DATA1	15:8	rw	Data1 byte content(bit0=LSB; bit7=MSB)
DATA0	7:0	rw	Data0 byte content(bit0=LSB; bit7=MSB)

Table 78 Reset of [SWK_DATA0_CTRL](#)

Register Reset Type	Reset Values	Reset Short Name	Reset Mode	Note
POR/Soft reset	0000 0000 0000 0000 _B			
Restart	XXXX XXXX XXXX XXXX _B			

Serial Peripheral Interface

CAN FD Configuration Control Register

SWK_CAN_FD_CTRL

CAN FD Configuration Control Register

(011 1011_B)

Reset Value: see [Table 79](#)

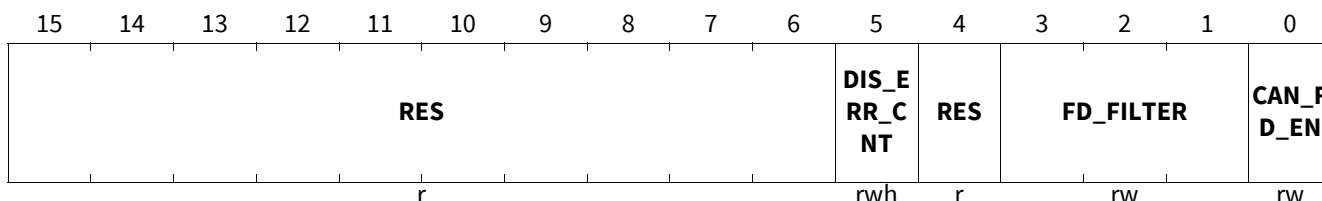

Field	Bits	Type	Description
RES	15:6	r	Reserved, always reads as 0
DIS_ERR_CNT	5	rwh	Error Counter Disable Function 0 _B ENABLED , Error Counter is enabled during SWK 1 _B DISABLED , Error counter is disabled during SWK only if CAN_FD_EN = '1'
RES	4	r	Reserved, always reads as 0
FD_FILTER	3:1	rw	CAN FD Dominant Filter Time 000 _B 50ns , 50 ns 001 _B 100ns , 100 ns 010 _B 150ns , 150 ns 011 _B 200ns , 200 ns 100 _B 250ns , 250 ns 101 _B 300ns , 300 ns 110 _B 350ns , 350 ns 111 _B 775ns , 775 ns
CAN_FD_EN	0	rw	Enable CAN FD Tolerant Mode 0 _B DISABLED , CAN FD Tolerant Mode disabled 1 _B ENABLED , CAN FD Tolerant Mode enabled

Table 79 Reset of SWK_CAN_FD_CTRL

Register Reset Type	Reset Values	Reset Short Name	Reset Mode	Note
POR/Soft reset	0000 0000 0000 0000 _B			
Restart	0000 0000 00x0 xxxx _B			

Notes

1. **DIS_ERR_CNT** is cleared by the device at tsilence expiration.
2. The Normal Mode CAN Receiver (**RX_WK_SEL** = 0_B) has to selected with a CAN FD tolerant operation for baud rates > 2 MBit/s.

Serial Peripheral Interface

14.5.4 Selective Wake trim and configuration Registers

SWK Oscillator Trimming and option Register

SWK_OSC_TRIM_CTRL

SWK Oscillator Trimming and option Register

(011 1100_B)

Reset Value: see [Table 80](#)



Field	Bits	Type	Description
RES	15	r	Reserved, always reads as 0
RX_WK_SEL	14	rw	SWK Receiver selection (only accessible if TRIM_EN = '11') 0 _B LOW_POWER, Low-Power Receiver selected during SWK 1 _B STD, Standard Receiver selected during SWK
RES	13:12	r	Reserved, always reads as 0
TEMP_COEF	11:7	rw	Trimming of temp_coef (only writable if TRIM_EN = '11')
TRIM_OSC	6:0	rw	Trimming of oscillator (only writable if TRIM_EN = '11')

Table 80 Reset of SWK_OSC_TRIM_CTRL

Register Reset Type	Reset Values	Reset Short Name	Reset Mode	Note
POR/Soft reset	0000 0000 0000 0000 _B			
Restart	0x00 xxxx xxxx xxxx _B			

Notes

- The bit RX_WK_SEL is used to select the respective receiver during Selective Wake operation. The lowest quiescent current during Frame Detect Mode is achieved with the default setting RX_WK_SEL = '0', i.e. the Low-Power Receiver is already selected.
- TRIM_OSC[6:0] represent the 128-steps coarse trimming range, which is not monotonous. It is not recommended to change these values.

Serial Peripheral Interface

SWK Oscillator Calibration Register

SWK_OSC_CAL_STAT

SWK Oscillator Calibration Register

(011 1101_B)

Reset Value: see [Table 81](#)

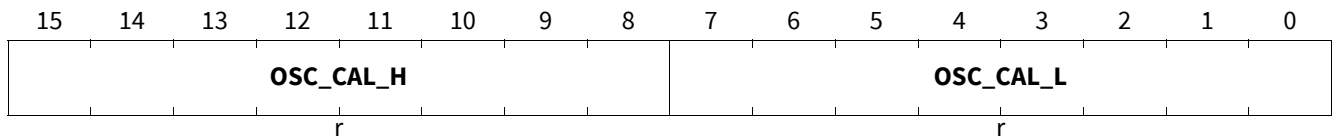

Field	Bits	Type	Description
OSC_CAL_H	15:8	r	Oscillator Calibration High Register
OSC_CAL_L	7:0	r	Oscillator Calibration Low Register

Table 81 Reset of [SWK_OSC_CAL_STAT](#)

Register Reset Type	Reset Values	Reset Short Name	Reset Mode	Note
POR/Soft reset	0000 0000 0000 0000 _B			
Restart	XXXX XXXX XXXX XXXX _B			

Serial Peripheral Interface

Clock Data Recovery Control Register

SWK_CDR_CTRL

Clock Data Recovery Control Register

(011 1110_B)

Reset Value: see [Table 82](#)

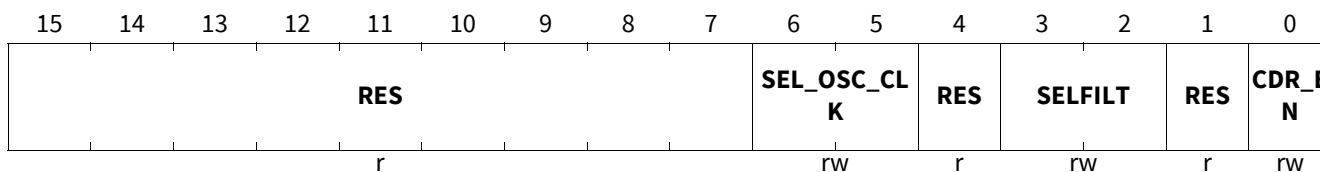

Field	Bits	Type	Description
RES	15:7	r	Reserved, always reads as 0
SEL_OSC_CLK	6:5	rw	Input Frequency for CDR module See Table 83 and Table 84
RES	4	r	Reserved, always reads as 0
SELFILT	3:2	rw	Select Time Constant of Filter 00 _B 8 , Time constant 8 01 _B 16 , Time constant 16 (default) 10 _B 32 , Time constant 32 11 _B ADAPTIVE , adapt distance between falling edges 2, 3 bit: Time constant 32 distance between f. edges 4, 5, 6, 7, 8 bit: Time constant 16 distance between falling edges 9, 10 bit: Time constant 8
RES	1	r	Reserved, always reads as 0
CDR_EN	0	rw	Enable CDR 0 _B DISABLED , CDR disabled 1 _B ENABLED , CDR enabled

Table 82 Reset of [SWK_CDR_CTRL](#)

Register Reset Type	Reset Values	Reset Short Name	Reset Mode	Note
POR/Soft reset	0000 0000 0000 0100 _B			
Restart	0000 0000 0xx0 xx0x _B			

Table 83 Frequency Settings of Internal Clock for the CDR

SEL_OSC_CLK[1:0]	int. Clock for CDR
00	75 MHz
01	37.5 MHz
10	18.75 MHz
11	9.375 MHz

Serial Peripheral Interface

Table 84 Recommended CDR Settings for Different Baud Rates

SEL_OSC_CLK [1:0]	Baudrate	SWK_BTL1_CTRL Value	SWK_CDR_LIMIT Value
00	500k	xxxx xxxx 1001 0110	1001 1101 1000 1111
01	500k	xxxx xxxx 0100 1011	0100 1110 0100 0111
10	500k	CDR Setting not recommended for this baudrate due to insufficient precision	
11	500k	CDR Setting not recommended for this baudrate due to insufficient precision	
00	250k	CDR Setting not to be used due to excessive time quanta (counter overflow)	
01	250k	xxxx xxxx 1001 0110	1001 1101 1000 1111
10	250k	xxxx xxxx 0100 1011	0100 1110 0100 0111
11	250k	CDR Setting not recommended for this baudrate due to insufficient precision	
00	125k	CDR Setting not to be used due to excessive time quanta (counter overflow)	
01	125k	CDR Setting not to be used due to excessive time quanta (counter overflow)	
10	125k	xxxx xxxx 1001 0110	1001 1101 1000 1111
11	125k	xxxx xxxx 0100 1011	0100 1110 0100 0111

Serial Peripheral Interface

SWK Clock Data Recovery Limit Control

SWK_CDR_LIMIT

SWK Clock Data Recovery Limit Control

(011 1111_B)

Reset Value: see [Table 85](#)

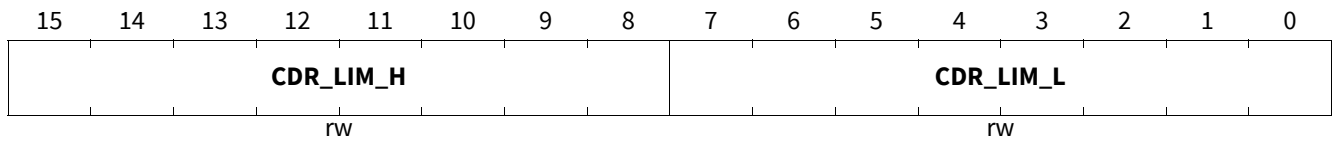

Field	Bits	Type	Description
CDR_LIM_H	15:8	rw	Upper Bit Time Detection Range of Clock and Data Recovery x values > + 5% will be clamped
CDR_LIM_L	7:0	rw	Lower Bit Time Detection Range of Clock and Data Recovery x values > - 5% will be clamped

Table 85 Reset of [SWK_CDR_LIMIT](#)

Register Reset Type	Reset Values	Reset Short Name	Reset Mode	Note
POR/Soft reset	1001 1101 1000 1111 _B			
Restart	XXXX XXXX XXXX XXXX _B			

Serial Peripheral Interface

14.6 SPI status information registers

READ/CLEAR Operation (see also [Chapter 14.3](#)):

- One 32-bit SPI command consist of four bytes:
 - The 7-bit address and one additional bit for the register access mode and
 - following the two data bytes and the CRC.
 The numbering of following bit definitions refers to the data byte and correspond to the bits D0...D7 and to the SPI bits 8...23 (see also figure).
- There are two different bit types:
 - ‘r’ = READ: read only bits (or reserved bits).
 - ‘rc’ = READ/CLEAR: readable and clearable bits.
- Reading a register is done word wise by setting the SPI bit 7 to “0” (= Read Only).
- Clearing a register is done word wise by setting the SPI bit 7 to “1”. No single bits can be cleared. Therefore the content of a SPI message (bit 8..23) doesn’t matter.
- SPI status registers are in general not cleared or changed automatically (an exception are the x bits). This must be done by the microcontroller via SPI command.

The registers are addressed wordwise.

Table 86 Register Overview

Register Short Name	Register Long Name	Offset Address	Page Number
SPI status information registers, Device Status Registers			
SUP_STAT	Supply Voltage Fail Status	1000000 _B	250
THERM_STAT	Thermal Protection Status	1000001 _B	252
DEV_STAT	Device Information Status	1000010 _B	253
BUS_STAT	Bus Communication Status	1000011 _B	255
WK_STAT	Wake-up Source and Information Status	1000100 _B	257
WK_LVL_STAT	WK Input Level	1000101 _B	259
HS_OL_OC_OT_STAT	High-Side Switch Status	1000110 _B	260
SPI status information registers, Status registers bridge driver			
GEN_STAT	GEN Status register	1010000 _B	262
TDREG	Turn-on/off delay regulation register	1010001 _B	264
DSOV	Drain-source overvoltage HBVOUT	1010010 _B	266
EFF_TDON_OFF1	Effective MOSFET turn-on/off delay - PWM half-bridge 1	1010011 _B	268
EFF_TDON_OFF2	Effective MOSFET turn-on/off delay - PWM half-bridge 2	1010100 _B	269
EFF_TDON_OFF3	Effective MOSFET turn-on/off delay - PWM half-bridge 3	1010101 _B	270
EFF_TDON_OFF4	Effective MOSFET turn-on/off delay - PWM half-bridge 4	1010110 _B	271
TRISE_FALL1	MOSFET rise/fall time - PWM half-bridge 1	1010111 _B	272
TRISE_FALL2	MOSFET rise/fall time - PWM half-bridge 2	1011000 _B	273
TRISE_FALL3	MOSFET rise/fall time - PWM half-bridge 3	1011001 _B	274

Serial Peripheral Interface

Table 86 Register Overview (cont'd)

Register Short Name	Register Long Name	Offset Address	Page Number
TRISE_FALL4	MOSFET rise/fall time - PWM half-bridge 4	1011010 _B	275
SPI status information registers, Selective wake status registers			
SWK_STAT	Selective Wake Status	1100000 _B	276
SWK_ECNT_STAT	Selective Wake ECNT Status	1100001 _B	277
SWK_CDR_STAT	Selective Wake CDR Status	1100011 _B	278
SPI status information registers, Family and product information register			
FAM_PROD_STAT	Family and Product Identification Register	1110000 _B	279

Serial Peripheral Interface

14.6.1 Device Status Registers

Supply Voltage Fail Status

SUP_STAT

Supply Voltage Fail Status

(100 0000_B)

Reset Value: see [Table 87](#)

15	14	13	12	11	10	9	8	7	6	5	4	3	2	1	0
POR	RES	CP_OT	VCC1_UV_FS	HS_UV	HS_OV	VSINT_UV	VSINT_OV	VS_UV	VS_OV	CP_UV	VCC1_SC	VCC1_UV	VCC1_OV	VCC1_WARN	
rc	r	rc	rc	rc	rc	rc	rc	rc	rc	rc	rc	rc	rc	rc	rc

Field	Bits	Type	Description
POR	15	rc	Power-On reset detection 0 _B NO_POR, No POR 1 _B POR, POR occurred
RES	14:13	r	Reserved, always reads as 0
CP_OT	12	rc	Charge pump overtemperature 0 _B NO_CP_OT, No charge pump OT detected 1 _B CP_OT, Charge pump OT detected
VCC1_UV_FS	11	rc	4th consecutive VCC1 UV-Detection 0 _B NO_FAILSAFE, No Fail-Safe Mode entry due to 4th consecutive VCC1_UV 1 _B FAILSAFE, Fail-Safe Mode entry due to 4th consecutive VCC1_UV
HS_UV	10	rc	HS Supply UV-Detection 0 _B NO_UV, No Undervoltage 1 _B UV_EVENT, HS Supply Undervoltage detected
HS_OV	9	rc	HS Supply OV-Detection 0 _B NO_OV, No Overvoltage 1 _B OV_EVENT, HS Supply Overvoltage detected
VSINT_UV	8	rc	VSINT UV-Detection 0 _B NO_UV, No Undervoltage 1 _B UV_EVENT, VSINT Undervoltage detected
VSINT_OV	7	rc	VSINT OV-Detection 0 _B NO_OV, No Overvoltage 1 _B OV_EVENT, VSINT Overvoltage detected
VS_UV	6	rc	VS Undervoltage Detection (V_{s,uv}) 0 _B NO_VS, No VS undervoltage detected 1 _B VS_EVENT, VS undervoltage detected (detection is only active when VCC1 is enabled)
VS_OV	5	rc	VS Overvoltage Detection (V_{s,ov}) 0 _B NO_OV, No VS overvoltage detected 1 _B OV_EVENT, VS overvoltage detected (detection is only active when VCC1 is enabled)

Serial Peripheral Interface

Field	Bits	Type	Description
CP_UV	4	rc	CP_UV 0 _B NO_UV , No CP undervoltage detected 1 _B UV_EVENT , CP undervoltage detected
VCC1_SC	3	rc	VCC1 SC 0 _B NO_SC , No VCC1 short to GND detected 1 _B SC_EVENT , VCC1 short to GND
VCC1_UV	2	rc	VCC1 UV-Detection (due to Vrtx reset) 0 _B NO_UV , No VCC1_UV detection 1 _B UV_EVENT , VCC1 undervoltage detected
VCC1_OV	1	rc	VCC1 Overvoltage Detection 0 _B NO_OV , No VCC1 overvoltage warning 1 _B OV_EVENT , VCC1 overvoltage detected
VCC1_WARN	0	rc	VCC1 Undervoltage Prewarning 0 _B NO_UV , No VCC1 undervoltage prewarning 1 _B UV_PREWARN , VCC1 undervoltage prewarning detected

Table 87 Reset of SUP_STAT

Register Reset Type	Reset Values	Reset Short Name	Reset Mode	Note
POR/Soft reset	y000 0000 0000 0000 _B			
Restart	x00x xxxx xxxx xxxx _B			

Notes

1. The VCC1 undervoltage prewarning threshold $V_{PW,f}/V_{PW,r}$ is a fixed threshold and independent of the VCC1 undervoltage reset thresholds.
2. VSINT undervoltage monitoring is not available in Stop Mode due to current consumption saving requirements. Exception: VSINT undervoltage detection is also available in Stop Mode if the VCC1 load current is above the active peak threshold (I_{PEAK_TH}) or if VCC1 is below the VCC1 prewarning threshold (**VCC1_WARN** is set).
3. The MSB of the POR/Soft Reset value is marked as 'y': the default value of the POR bit is set after Power-on reset (POR value = 1000 0000). However it will be cleared after a device Soft Reset command (Soft Reset value = 0000 0000).
4. During Sleep Mode, the bits VCC1_SC, VCC1_OV and VCC1_UV will not be set when VCC1 is off.
5. The VCC1_UV bit is never updated in Restart Mode, in Init Mode it is only updated after RSTN was released, it is always updated in Normal Mode and Stop Mode, and it is always updated in any device modes in a VCC1_SC condition (after VCC1_UV = 1 for > 2 ms).

Serial Peripheral Interface

Thermal Protection Status

THERM_STAT

Thermal Protection Status

(100 0001_B)

Reset Value: see [Table 88](#)

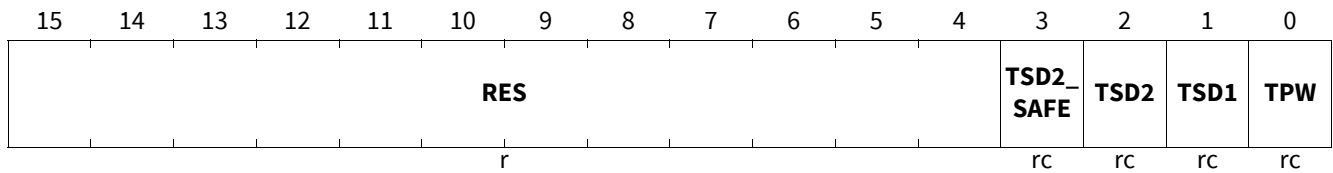

Field	Bits	Type	Description
RES	15:4	r	Reserved, always reads as 0
TSD2_SAFE	3	rc	TSD2 Thermal Shut-Down Safe State Detection 0 _B NO_TSD2_SF , No TSD2 safe state detected 1 _B TSD2_SF , TSD2 safe state detected: >16 consecutive TSD2 events occurred, next TSD2 waiting time will be 64s
TSD2	2	rc	TSD2 Thermal Shut-Down Detection 0 _B NO_TSD2 , No TSD2 event 1 _B TSD2_EVENT , TSD2 OT detected - leading to Fail-Safe Mode
TSD1	1	rc	TSD1 Thermal Shut-Down Detection 0 _B NO_TSD1 , No TSD1 fail 1 _B TSD1_EVENT , TSD1 OT detected (affected module is disabled)
TPW	0	rc	Thermal Pre Warning 0 _B NO_TPW , No Thermal Pre warning 1 _B TPW , Thermal Pre warning detected

Table 88 Reset of **THERM_STAT**

Register Reset Type	Reset Values	Reset Short Name	Reset Mode	Note
POR/Soft reset	0000 0000 0000 0000 _B			
Restart	0000 0000 0000 xxxx _B			

Note: Temperature warning and shutdown bits are not reset automatically, even if the temperature pre warning or the TSD condition is not present anymore.

Serial Peripheral Interface

Device Information Status

DEV_STAT

Device Information Status

(100 0010_B)

Reset Value: see [Table 89](#)

15	14	13	12	11	10	9	8	7	6	5	4	3	2	1	0
RES						CRC_S TAT	CRC_F AIL	DEV_STAT	RES	SW_D EV	WD_FAIL	SPI_F AIL	FAILU RE		
r						r	rc	rc	r	rh	rh	rc	rc		

Field	Bits	Type	Description
RES	15:10	r	Reserved, always read as 0
CRC_STAT	9	r	CRC STAT Information 0 _B DISABLED , CRC disabled 1 _B ENABLED , CRC enabled
CRC_FAIL	8	rc	CRC Fail Information¹⁾ 0 _B NO_FAIL , No CRC Failure 1 _B FAIL , CRC Failure detected
DEV_STAT	7:6	rc	Device Status before Restart Mode 00 _B CLEARED , Cleared (Register must be actively cleared) 01 _B RESTART , Restart due to failure (WD fail, TSD2, VCC1_UV, trial to access Sleep Mode without any wake source activated); also after a wake from Fail-Safe Mode 10 _B SLEEP , Sleep Mode 11 _B , reserved
RES	5	r	Reserved, always reads 0
SW_DEV	4	rh	Status of Operating Mode 0 _B NORMAL , Normal operation 1 _B SW_DEV , Software Development Mode is enabled
WD_FAIL	3:2	rh	Number of WD-Failure Events 00 _B NO_FAIL , No WD Fail 01 _B 1x , 1x WD Fail, 10 _B 2x , 2x WD Fail 11 _B 3x , more than 3xWD Fail
SPI_FAIL	1	rc	SPI Fail Information 0 _B NO_FAIL , No SPI fail 1 _B INVALID , Invalid SPI command detected
FAILURE	0	rc	Failure detection 0 _B NO_FAIL , No Failure 1 _B FAIL , Failure occurred

1) The CRC_FAIL bit will not be set in case the static CRC enabling / disabling sequence is sent (see [Chapter 5.2](#)).

Serial Peripheral Interface

Table 89 Reset of **DEV_STAT**

Register Reset Type	Reset Values	Reset Short Name	Reset Mode	Note
POR/Soft reset	0000 0000 0000 0000 _B			
Restart	0000 00xx xx0x xxxx _B			

Notes

1. The bits **DEV_STAT** show the status of the device before exiting Restart Mode. Either the device came from regular Sleep Mode or a failure (Restart Mode or Fail-Safe Mode) occurred. Coming from Sleep Mode will also be shown if there was a trial to enter Sleep Mode without having cleared all wake flags before.
2. The **WD_FAIL** bits are implemented as a counter and are the only status bits, which are cleared automatically by the device.
3. The **SPI_FAIL** bit can only be cleared via SPI command.
4. The bit **CRC_STAT** and **CRC_FAIL** can be read regardless the CRC setting. The SPI read command on **DEV_STAT** ignores the CRC field.

Serial Peripheral Interface

Bus Communication Status

BUS_STAT

Bus Communication Status

(100 0011_B)

Reset Value: see [Table 90](#)

15	14	13	12	11	10	9	8	7	6	5	4	3	2	1	0
RES							LIN_FAIL	CANT O	SYSER R	CAN_FAIL		VCAN_ UV			
r							rc	rc	rc	rc		rc			

Field	Bits	Type	Description
RES	15:7	r	Reserved, always reads as 0
LIN_FAIL	6:5	rc	LIN failure status 00 _B NO_FAIL , No failures 01 _B LIN_TSD , LIN Thermal shutdown 10 _B LIN_TXD_DOM_TO , LIN_TXD_DOM: detected a TXDLIN dominant timeout 11 _B LIN_BUS_DOM_TO , LIN_BUS_DOM: detected a LIN dominant timeout
CANTO	4	rc	CAN Time Out Detection 0 _B NO_FAIL , Normal operation 1 _B TIME_OUT , CAN Time Out detected
SYSERR	3	rc	SWK System Error 0 _B NO_FAIL , Selective Wake Mode is possible 1 _B FAIL , System Error detected, SWK enabling not possible
CAN_FAIL	2:1	rc	CAN failure status 00 _B NO_ERR , No error 01 _B CAN_TSD , CAN Thermal shutdown 10 _B CAN_TXD_DOM_TO , CAN_TXD_DOM: TXD dominant time out detected 11 _B CAN_BUS_DOM_TO , CAN_BUS_DOM: BUS dominant time out detected
VCAN_UV	0	rc	Under Voltage CAN Bus Supply 0 _B NORMAL , Normal operation 1 _B UNDERVOLTAGE , CAN Supply undervoltage detected. Transmitter disabled

Table 90 Reset of **BUS_STAT**

Register Reset Type	Reset Values	Reset Short Name	Reset Mode	Note
POR/Soft reset	0000 0000 0000 0000 _B			
Restart	0000 0000 0xxx xxxx _B			

Notes

1. The VCAN_UV comparator is enabled if CAN Normal or CAN Receive Only Mode.

Serial Peripheral Interface

2. *CAN and LIN Recovery Conditions:*
 - 1.) *TXD Time Out: TXD goes HIGH or transmitter is set to wake capable or switched off.*
 - 2.) *Bus dominant time out: Bus will become recessive or transceiver is set to wake capable or switched off.*
 - 3.) *Supply under voltage: as soon as the threshold is crossed again, i.e. $V_{CAN} > V_{CAN_UV}$ for CAN.*
 - 4.) *In all cases (also for TSD shutdown): to enable the Bus transmission again, TXD needs to be HIGH (recessive) for a certain time (transmitter enable time).*
3. *CANTO will be set only if $CAN2 = 1$ (=SWK Mode enabled). It will be set as soon as CANSIL was set and will stay set even in CANSIL it is reset. An interrupt is issued in Stop Mode and Normal Mode as soon as CANTO is set and the interrupt is not masked out, i.e. CANTO_MASK must be set to 1.*
4. *The SYSERR Flag is set in case of a configuration error and in case of an error counter overflow ($n > 32$) It is only updated if SWK is enabled ($CAN_2 = '1'$). See also chapter x.*
5. *CANTO is set asynchronously to the INTN pulse. In order to prevent undesired clearing of CANTO and thus possibly missing this interrupt, the bit will be prevented from clearing (i.e. cannot be cleared) until the next falling edge of INTN.*

Serial Peripheral Interface

Wake-up Source and Information Status

WK_STAT

Wake-up Source and Information Status

(100 0100_B)

Reset Value: see [Table 91](#)

15	14	13	12	11	10	9	8	7	6	5	4	3	2	1	0
RES				LIN_WU	CAN_WU	TIMER2_WU	TIMER1_WU	RES		RES	WK4_WU	WK3_WU	WK2_WU	WK1_WU	
r				rc	rc	rc	rc	r		r	rc	rc	rc	rc	

Field	Bits	Type	Description
RES	15:11	r	Reserved, always reads as 0
LIN_WU	10	rc	LIN wake up 0 _B NO_WU, No Wake up 1 _B WU, Wake up detected
CAN_WU	9	rc	Wake up via CAN Bus 0 _B NO_WU, No Wake up 1 _B WU, Wake up detected
TIMER2_WU	8	rc	Wake up via Timer2 0 _B NO_WU, No Wake up 1 _B WU, Wake up detected
TIMER1_WU	7	rc	Wake up via Timer1 0 _B NO_WU, No Wake up 1 _B WU, Wake up detected
RES	6:5	r	Reserved, always reads as 0
RES	4	r	Reserved, always reads as 0
WK4_WU	3	rc	Wake up via WK4 0 _B NO_WU, No Wake up 1 _B WU, Wake up detected
WK3_WU	2	rc	Wake up via WK3 0 _B NO_WU, No Wake up 1 _B WU, Wake up detected
WK2_WU	1	rc	Wake up via WK2 0 _B NO_WU, No Wake up 1 _B WU, Wake up detected
WK1_WU	0	rc	Wake up via WK1 0 _B NO_WU, No Wake up 1 _B WU, Wake up detected

Table 91 Reset of WK_STAT

Register Reset Type	Reset Values	Reset Short Name	Reset Mode	Note
POR/Soft reset	0000 0000 0000 0000 _B			
Restart	0000 0xxx x000 00x0 _B			

Serial Peripheral Interface

Note: At Fail-Safe Mode entry, the **WK_STAT** register is automatically cleared by the device.

Serial Peripheral Interface

WK Input Level

WK_LVL_STAT

WK Input Level

(100 0101_B)

Reset Value: see [Table 92](#)

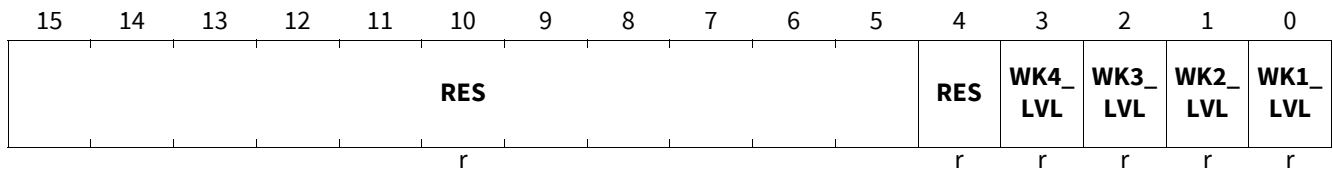

Field	Bits	Type	Description
RES	15:5	r	Reserved, always reads as 0
RES	4	r	Reserved, always reads as 0
WK4_LVL	3	r	Status of WK4 0 _B LOW , Low Level (=0) 1 _B HIGH , High Level (=1)
WK3_LVL	2	r	Status of WK3 0 _B LOW , Low Level (=0) 1 _B HIGH , High Level (=1)
WK2_LVL	1	r	Status of WK2 0 _B LOW , Low Level (=0) 1 _B HIGH , High Level (=1)
WK1_LVL	0	r	Status of WK1 0 _B LOW , Low Level (=0) 1 _B HIGH , High Level (=1)

Table 92 Reset of [WK_LVL_STAT](#)

Register Reset Type	Reset Values	Reset Short Name	Reset Mode	Note
POR/Soft reset	0000 0000 0000 00x0 _B			
Restart	0000 0000 0000 00x0 _B			

Note: WK_LVL_STAT is updated in Normal Mode and Stop Mode and also in Init and Restart Mode. In cyclic sense or wake mode, the registers contain the sampled level, i.e. the registers are updated after every sampling.

Serial Peripheral Interface

High-Side Switch Status

HS_OL_OC_OT_STAT

High-Side Switch Status

(100 0110_B)

Reset Value: see [Table 93](#)

15	14	13	12	11	10	9	8	7	6	5	4	3	2	1	0
RES	HS4_OT	HS3_OT	HS2_OT	HS1_OT	RES	HS4_OL	HS3_OL	HS2_OL	HS1_OL	RES	HS4_OC	HS3_OC	HS2_OC	HS1_OC	
r	rc	rc	rc	rc	r	rc	rc	rc	rc	r	rc	rc	rc	rc	rc

Field	Bits	Type	Description
RES	15:14	r	Reserved, always reads as 0
HS4_OT	13	rc	Overtemperature Detection on HS4 0 _B NO_OT, No OT 1 _B OT, OT detected
HS3_OT	12	rc	Overtemperature Detection on HS3 0 _B NO_OT, No OT 1 _B OT, OT detected
HS2_OT	11	rc	Overtemperature Detection on HS2 0 _B NO_OT, No OT 1 _B OT, OT detected
HS1_OT	10	rc	Overtemperature Detection on HS1 0 _B NO_OT, No OT 1 _B OT, OT detected
RES	9	r	Reserved, always reads as 0
HS4_OL	8	rc	Open-Load Detection on HS4 0 _B NO_OL, No OL 1 _B OL, OL detected
HS3_OL	7	rc	Open-Load Detection on HS3 0 _B NO_OL, No OL 1 _B OL, OL detected
HS2_OL	6	rc	Open-Load Detection on HS2 0 _B NO_OL, No OL 1 _B OL, OL detected
HS1_OL	5	rc	Open-Load Detection on HS1 0 _B NO_OL, No OL 1 _B OL, OL detected
RES	4	r	Reserved, always reads as 0
HS4_OC	3	rc	Overcurrent Detection on HS4 0 _B NO_OC, No OC 1 _B OC, OC detected
HS3_OC	2	rc	Overcurrent Detection on HS3 0 _B NO_OC, No OC 1 _B OC, OC detected

Serial Peripheral Interface

Field	Bits	Type	Description
HS2_OC	1	rc	Overcurrent Detection on HS2 0 _B NO_OC , No OC 1 _B OC , OC detected
HS1_OC	0	rc	Overcurrent Detection on HS1 0 _B NO_OC , No OC 1 _B OC , OC detected

Table 93 Reset of **HS_OL_OC_OT_STAT**

Register Reset Type	Reset Values	Reset Short Name	Reset Mode	Note
POR/Soft reset	0000 0000 0000 0000 _B			
Restart	00xx xxxx xxxx xxxx _B			

14.6.2 Status registers bridge driver

General Status register

GEN_STAT

General Status register

(101 0000_B)

Reset Value: see [Table 94](#)

15	14	13	12	11	10	9	8	7	6	5	4	3	2	1	0
RES						HB4V OUT	HB3V OUT	HB2V OUT	HB1V OUT	RES	RES	RES	PWM3 STAT	RES	PWM1 STAT
r						r	r	r	r	r	r	r	r	r	r

Field	Bits	Type	Description
RES	15:10	r	Reserved, always reads as 0
HB4VOUT	9	r	Voltage level at VSH4 when HB4MODE[1:0] = 11 and CPEN=1 ¹⁾ 0 _B LOW, VSH4 = Low : VS - VSH4 > V _{HS4VDSTHx} 1 _B HIGH, VSH4 = High: VS - VSH4 ≤ V _{HS4VDSTHx}
HB3VOUT	8	r	Voltage level at VSH3 when HB3MODE[1:0] = 11 and CPEN=1 ¹⁾ 0 _B LOW, VSH3 = Low : VS - VSH3 > V _{HS3VDSTHx} 1 _B HIGH, VSH3 = High: VS - VSH3 ≤ V _{HS3VDSTHx}
HB2VOUT	7	r	Voltage level at VSH2 when HB2MODE[1:0] = 11 and CPEN=1 ¹⁾ 0 _B LOW, VSH2 = Low : VS - VSH2 > V _{HS2VDSTHx} 1 _B HIGH, VSH2 = High: VS - VSH2 ≤ V _{HS2VDSTHx}
HB1VOUT	6	r	Voltage level at VSH1 when HB1MODE[1:0] = 11 and CPEN=1 ¹⁾ 0 _B LOW, VSH1 = Low : VS - VSH1 > V _{HS1VDSTHx} 1 _B HIGH, VSH1 = High: VS - VSH1 ≤ V _{HS1VDSTHx}
RES	5	r	Reserved, always reads as 0
RES	4	r	Reserved, always reads as 0
RES	3	r	Reserved, always reads as 0
PWM3STAT	2	r	PWM3 status 0 _B LOW, PWM3 is Low 1 _B HIGH, PWM3 is High
RES	1	r	Reserved, always reads as 0
PWM1STAT	0	r	PWM1/CRC status 0 _B LOW, PWM1/CRC is Low 1 _B HIGH, PWM1/CRC is High

1) HBxVOUT = 0 if (CPEN=1 and HBxMODE ≠ 11) or CPEN=0.

Serial Peripheral Interface

Table 94 Reset of **GEN_STAT**

Register Reset Type	Reset Values	Reset Short Name	Reset Mode	Note
POR/Soft reset	0000 0000 0000 0000 _B			
Restart	0000 0000 xx00 000x _B			

Serial Peripheral Interface

Turn-on/off delay regulation register

TDREG

Turn-on/off delay regulation register

(101 0001_B)

Reset Value: see [Table 95](#)

15	14	13	12	11	10	9	8	7	6	5	4	3	2	1	0
RES				IPDCH G4_ST	IPDCH G3_ST	IPDCH G2_ST	IPDCH G1_ST	IPCHG 4_ST	IPCHG 3_ST	IPCHG 2_ST	IPCHG 1_ST	TDRE G4	TDRE G3	TDRE G2	TDRE G1
r				r	r	r	r	r	r	r	r	r	r	r	r

Field	Bits	Type	Description
RES	15:12	r	Reserved, always reads as 0
IPDCHG4_ST	11	r	HB4 predischage status 0 _B CLAMP , the predischage current is equal to 0.5 mA typ. or ICHGMAX4 if AGC[1:0] = 10 _B or 11 _B , and HB4_PWM_EN = 1 ¹⁾ 1 _B NO_CLAMP , 0.5 mA < predischage current < ICHGMAX4 ¹⁾
IPDCHG3_ST	10	r	HB3 predischage status 0 _B CLAMP , the predischage current is equal to 0.5 mA typ. or ICHGMAX3 if AGC[1:0] = 10 _B or 11 _B , and HB3_PWM_EN = 1 ¹⁾ 1 _B NO_CLAMP , 0.5 mA < predischage current < ICHGMAX3 ¹⁾
IPDCHG2_ST	9	r	HB2 predischage status 0 _B CLAMP , the predischage current is equal to 0.5 mA typ. or ICHGMAX2 if AGC[1:0] = 10 _B or 11 _B , and HB2_PWM_EN = 1 ¹⁾ 1 _B NO_CLAMP , 0.5 mA < predischage current < ICHGMAX2 ¹⁾
IPDCHG1_ST	8	r	HB1 predischage status 0 _B CLAMP , the predischage current is equal to the 0.5 mA typ. or ICHGMAX1 if AGC[1:0] = 10 _B or 11 _B , and HBx_PWM_EN = 1 ¹⁾ 1 _B NO_CLAMP , 0.5 mA < predischage current < ICHGMAX1 ¹⁾
IPCHG4_ST	7	r	HB4 discharge status 0 _B CLAMP , the discharge current is equal to 0.5 mA typ. or ICHGMAX4 if AGC[1:0] = 10 _B or 11 _B , and HB4_PWM_EN = 1 ¹⁾ 1 _B NO_CLAMP , 0.5 mA < discharge current < ICHGMAX4 ¹⁾

Serial Peripheral Interface

Field	Bits	Type	Description
IPCHG3_ST	6	r	HB3 precharge status 0_B CLAMP , the precharge current is equal to 0.5 mA typ. or ICHGMAX3 if AGC[1:0] = 10_B or 11_B , and HB3_PWM_EN = 1^1 1_B NO_CLAMP , 0.5 mA < precharge current < ICHGMAX3 ¹⁾
IPCHG2_ST	5	r	HB2 precharge status 0_B CLAMP , the precharge current is equal to 0.5 mA typ. or ICHGMAX2 if AGC[1:0] = 10_B or 11_B , and HB2_PWM_EN = 1^1 1_B NO_CLAMP , 0.5 mA < precharge current < ICHGMAX2 ¹⁾
IPCHG1_ST	4	r	HB1 precharge status 0_B CLAMP , the precharge current is equal to the 0.5 mA typ. or ICHGMAX1 if AGC[1:0] = 10_B or 11_B , and HB1_PWM_EN = 1^1 1_B NO_CLAMP , 0.5 mA < precharge current < ICHGMAX1 ¹⁾
TDREG4	3	r	HB4 Regulation of turn-on/off delay 0_B NO_REG , tDON4 and tDOFF4 are not in regulation 1_B REG , tDON4 and/or tDOFF4 are in regulation
TDREG3	2	r	HB3 Regulation of turn-on/off delay 0_B NO_REG , tDON3 and tDOFF3 are not in regulation 1_B REG , tDON3 and/or tDOFF3 are in regulation
TDREG2	1	r	HB2 Regulation of turn-on/off delay 0_B NO_REG , tDON2 and tDOFF2 are not in regulation 1_B REG , tDON2 and/or tDOFF2 are in regulation
TDREG1	0	r	HB1 Regulation of turn-on/off delay 0_B NO_REG , tDON and tDOFF are not in regulation 1_B REG , tDON and/or tDOFF are in regulation

1) IPCHGx_ST = 1 otherwise (PWM disabled, HB in high impedance or AGC[1:0] = 00_B or 01_B).

Table 95 Reset of **TDREG**

Register Reset Type	Reset Values	Reset Short Name	Reset Mode	Note
POR/Soft reset	0000 0000 0000 0000 _B			
Restart	0000 0000 xx00 000x _B			

Serial Peripheral Interface

Drain-source overvoltage status

DSOV

Drain-source overvoltage

(101 0010_B)

Reset Value: see [Table 96](#)

15	14	13	12	11	10	9	8	7	6	5	4	3	2	1	0
RES	RES	VSINT OVBR AKE_S T	VSOV BRAK E_ST	LS4DS OV_B RK	LS3DS OV_B RK	LS2DS OV_B RK	LS1DS OV_B RK	LS4DS OV	HS4D SOV	LS3DS OV	HS3D SOV	LS2DS OV	HS2D SOV	LS1DS OV	HS1D SOV
r	r	rc	rc	rc	rc	rc	rc	rc	rc	rc	rc	rc	rc	rc	rc

Field	Bits	Type	Description
RES	15	r	Reserved, always reads as 0
RES	14	r	Reserved, always reads as 0
VSINTOVBRAKE_ST	13	rc	VSINT Brake status 0 _B NOT_DETECT , VSINT overvoltage brake condition is not detected 1 _B DETECT , VSINT overvoltage brake conditions is detected
VSOVBRAKE_ST	12	rc	VS Brake status 0 _B NOT_DETECT , VS overvoltage brake conditions is not detected 1 _B DETECT , VS overvoltage brake conditions is detected
LS4DSOV_BRK	11	rc	Drain-source overvoltage on low-side 4 during braking 0 _B NO_OV , No drain-source overvoltage on LS4 1 _B OV , Drain-source overvoltage on LS4
LS3DSOV_BRK	10	rc	Drain-source overvoltage on low-side 3 during braking 0 _B NO_OV , No drain-source overvoltage on LS3 1 _B OV , Drain-source overvoltage on LS3
LS2DSOV_BRK	9	rc	Drain-source overvoltage on low-side 2 during braking 0 _B NO_OV , No drain-source overvoltage on LS2 1 _B OV , Drain-source overvoltage on LS2
LS1DSOV_BRK	8	rc	Drain-source overvoltage on low-side 1 during braking 0 _B NO_OV , No drain-source overvoltage on LS1 1 _B OV , Drain-source overvoltage on LS1
LS4DSOV	7	rc	Drain-source overvoltage on low-side 4 0 _B NO_OV , No drain-source overvoltage on LS4 1 _B OV , Drain-source overvoltage on LS4
HS4DSOV	6	rc	Drain-source overvoltage on high-side 4 0 _B NO_OV , No drain-source overvoltage on HS4 1 _B OV , Drain-source overvoltage on HS4

Serial Peripheral Interface

Field	Bits	Type	Description
LS3DSOV	5	rc	Drain-source overvoltage on low-side 3 0 _B NO_OV , No drain-source overvoltage on LS3 1 _B OV , Drain-source overvoltage on LS3
HS3DSOV	4	rc	Drain-source overvoltage on high-side 3 0 _B NO_OV , No drain-source overvoltage on HS3 1 _B OV , Drain-source overvoltage on HS3
LS2DSOV	3	rc	Drain-source overvoltage on low-side 2 0 _B NO_OV , No drain-source overvoltage on LS2 1 _B OV , Drain-source overvoltage on LS2
HS2DSOV	2	rc	Drain-source overvoltage on high-side 2 0 _B NO_OV , No drain-source overvoltage on HS2 1 _B OV , Drain-source overvoltage on HS2
LS1DSOV	1	rc	Drain-source overvoltage on low-side 1 0 _B NO_OV , No drain-source overvoltage on LS1 1 _B OV , Drain-source overvoltage on LS1
HS1DSOV	0	rc	Drain-source overvoltage on high-side 1 0 _B NO_OV , No drain-source overvoltage on HS1 1 _B OV , Drain-source overvoltage on HS1

Table 96 Reset of **DSOV**

Register Reset Type	Reset Values	Reset Short Name	Reset Mode	Note
POR/Soft reset	0000 0000 0000 0000 _B			
Restart	00xx xxxx xxxx xxxx _B			

Serial Peripheral Interface

Effective MOSFET turn.on/off delay - PWM half-bridge 1

EFF_TDON_OFF1

Effective MOSFET turn.on/off delay - HB1 (101 0011_B)

Reset Value: see [Table 97](#)

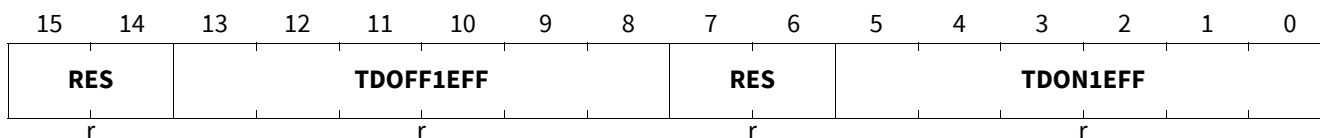

Field	Bits	Type	Description
RES	15:14	r	Reserved, always reads as 0
TDOFF1EFF	13:8	r	Effective active MOSFET turn-off delay HB1 Nominal effective tDOFF1 = 53.3 ns x TDOFF1EFF[13:8] _D
RES	7:6	r	Reserved, always reads as 0
TDON1EFF	5:0	r	Effective active MOSFET turn-on delay HB1 Nominal effective tDON1 = 53.3 ns x TDON1EFF[5:0] _D

Table 97 Reset of [EFF_TDON_OFF1](#)

Register Reset Type	Reset Values	Reset Short Name	Reset Mode	Note
POR/Soft reset	0000 0000 0000 0000 _B			
Restart	00xx xxxx 00xx xxxx _B			

Serial Peripheral Interface

Effective MOSFET turn.on/off delay - PWM half-bridge 2

EFF_TDON_OFF2

Effective MOSFET turn.on/off delay - HB 2 (101 0100_B)

Reset Value: see [Table 98](#)

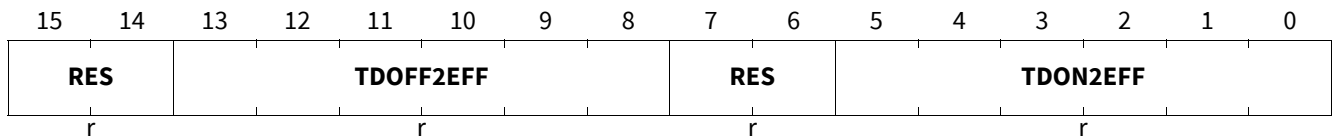

Field	Bits	Type	Description
RES	15:14	r	Reserved, always reads as 0
TDOFF2EFF	13:8	r	Effective active MOSFET turn-off delay HB2 Nominal effective tDOFF2 = 53.3 ns x TDOFF2EFF[13:8] _D
RES	7:6	r	Reserved, always reads as 0
TDON2EFF	5:0	r	Effective active MOSFET turn-on delay HB2 Nominal effective tDON2 = 53.3 ns x TDON2EFF[5:0] _D

Table 98 Reset of [EFF_TDON_OFF2](#)

Register Reset Type	Reset Values	Reset Short Name	Reset Mode	Note
POR/Soft reset	0000 0000 0000 0000 _B			
Restart	00xx xxxx 00xx xxxx _B			

Serial Peripheral Interface

Effective MOSFET turn.on/off delay - PWM half-bridge 3

EFF_TDON_OFF3

Effective MOSFET turn.on/off delay - HB3 (101 0101_B)

Reset Value: see [Table 99](#)

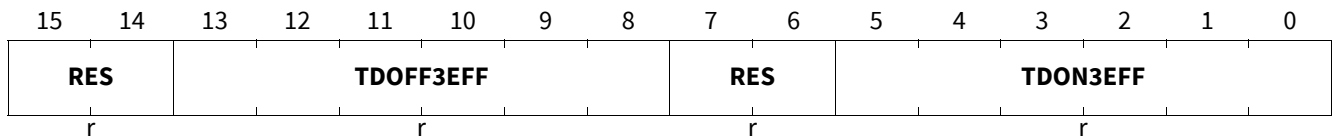

Field	Bits	Type	Description
RES	15:14	r	Reserved, always reads as 0
TDOFF3EFF	13:8	r	Effective active MOSFET turn-off delay HB3 Nominal effective tDOFF3 = 53.3 ns x TDO3EFF[13:8] _D
RES	7:6	r	Reserved, always reads as 0
TDON3EFF	5:0	r	Effective active MOSFET turn-on delay HB3 Nominal effective tDON3 = 53.3 ns x TDON3EFF[5:0] _D

Table 99 Reset of [EFF_TDON_OFF3](#)

Register Reset Type	Reset Values	Reset Short Name	Reset Mode	Note
POR/Soft reset	0000 0000 0000 0000 _B			
Restart	00xx xxxx 00xx xxxx _B			

Serial Peripheral Interface

Effective MOSFET turn.on/off delay - PWM half-bridge 4

EFF_TDON_OFF4

Effective MOSFET turn.on/off delay - HB4 (101 0110_B)

Reset Value: see [Table 100](#)

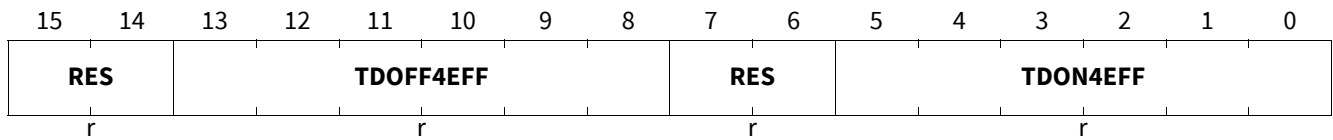

Field	Bits	Type	Description
RES	15:14	r	Reserved, always reads as 0
TDOFF4EFF	13:8	r	Effective active MOSFET turn-off delay HB4 Nominal effective tDOFF4 = 53.3 ns x TDOFF4EFF[13:8] _D
RES	7:6	r	Reserved, always reads as 0
TDON4EFF	5:0	r	Effective active MOSFET turn-on delay HB4 Nominal effective tDON4 = 53.3 ns x TDON4EFF[5:0] _D

Table 100 Reset of [EFF_TDON_OFF4](#)

Register Reset Type	Reset Values	Reset Short Name	Reset Mode	Note
POR/Soft reset	0000 0000 0000 0000 _B			
Restart	00xx xxxx 00xx xxxx _B			

Serial Peripheral Interface

MOSFET rise/fall time - PWM half-bridge 1

TRISE_FALL1

MOSFET rise/fall time - HB1

(101 0111_B)

Reset Value: see [Table 101](#)

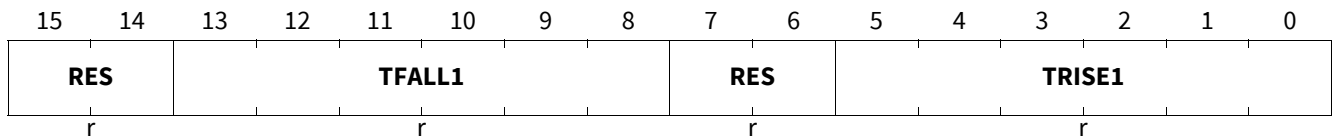

Field	Bits	Type	Description
RES	15:14	r	Reserved, always reads as 0
TFALL1	13:8	r	Active MOSFET fall time HB1 Nominal tFALL1 = 53.3 ns x TFALL1[5:0] _D
RES	7:6	r	Reserved, always reads as 0
TRISE1	5:0	r	Active MOSFET rise time HB1 Nominal tRISE1 = 53.3 ns x TRISE1[5:0] _D

Table 101 Reset of [TRISE_FALL1](#)

Register Reset Type	Reset Values	Reset Short Name	Reset Mode	Note
POR/Soft reset	0000 0000 0000 0000 _B			
Restart	00xx xxxx 00xx xxxx _B			

Serial Peripheral Interface

MOSFET rise/fall time - PWM half-bridge 2

TRISE_FALL2

MOSFET rise/fall time - HB2

(101 1000_B)

Reset Value: see [Table 102](#)

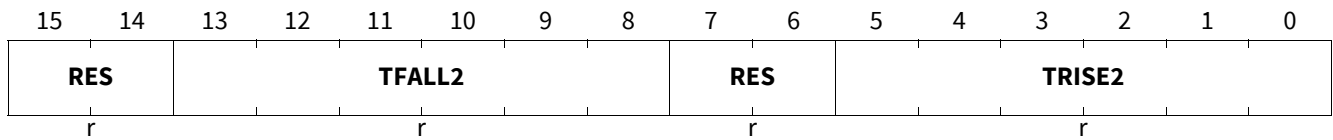

Field	Bits	Type	Description
RES	15:14	r	Reserved, always reads as 0
TFALL2	13:8	r	Active MOSFET fall time HB2 Nominal tFALL2 = 53.3 ns x TFALL2[5:0] _D
RES	7:6	r	Reserved, always reads as 0
TRISE2	5:0	r	Active MOSFET rise time HB2 Nominal tRISE2 = 53.3 ns x TRISE2[5:0] _D

Table 102 Reset of [TRISE_FALL2](#)

Register Reset Type	Reset Values	Reset Short Name	Reset Mode	Note
POR/Soft reset	0000 0000 0000 0000 _B			
Restart	00xx xxxx 00xx xxxx _B			

Serial Peripheral Interface

MOSFET rise/fall time - PWM half-bridge 3

TRISE_FALL3

MOSFET rise/fall time - HB3

(101 1001_B)

Reset Value: see [Table 103](#)

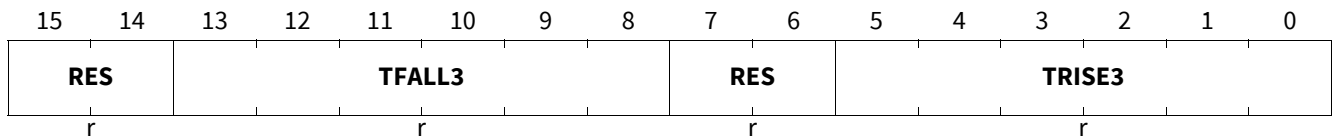

Field	Bits	Type	Description
RES	15:14	r	Reserved, always reads as 0
TFALL3	13:8	r	Active MOSFET fall time HB3 Nominal tFALL3 = 53.3 ns x TFALL3[5:0] _D
RES	7:6	r	Reserved, always reads as 0
TRISE3	5:0	r	Active MOSFET rise time HB3 Nominal tRISE3 = 53.3 ns x TRISE3[5:0] _D

Table 103 Reset of [TRISE_FALL3](#)

Register Reset Type	Reset Values	Reset Short Name	Reset Mode	Note
POR/Soft reset	0000 0000 0000 0000 _B			
Restart	00xx xxxx 00xx xxxx _B			

Serial Peripheral Interface

MOSFET rise/fall time - PWM half-bridge 4

TRISE_FALL4

MOSFET rise/fall time - HB4

(101 1010_B)

Reset Value: see [Table 104](#)

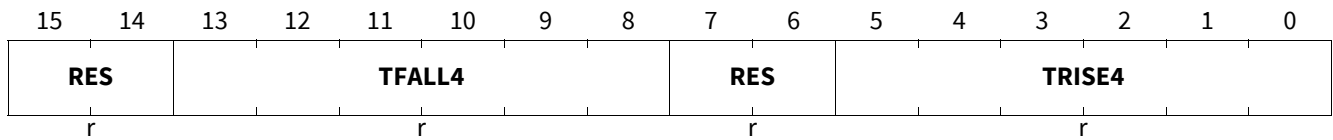

Field	Bits	Type	Description
RES	15:14	r	Reserved, always reads as 0
TFALL4	13:8	r	Active MOSFET fall time HB4 Nominal tFALL4 = 53.3 ns x TFALL4[5:0] _D
RES	7:6	r	Reserved, always reads as 0
TRISE4	5:0	r	Active MOSFET rise time HB4 Nominal tRISE4 = 53.3 ns x TRISE4[5:0] _D

Table 104 Reset of [TRISE_FALL4](#)

Register Reset Type	Reset Values	Reset Short Name	Reset Mode	Note
POR/Soft reset	0000 0000 0000 0000 _B			
Restart	00xx xxxx 00xx xxxx _B			

Serial Peripheral Interface

14.6.3 Selective wake status registers

Selective Wake Status

SWK_STAT

Selective Wake Status

(110 0000_B)

Reset Value: see [Table 105](#)

15	14	13	12	11	10	9	8	7	6	5	4	3	2	1	0
RES							SYNC	WUP	WUF	CANSIL	SWK_SET	RES			
r							r	rc	rc	r	r	r			

Field	Bits	Type	Description
RES	15:7	r	Reserved, always reads as 0
SYNC	6	r	Synchronisation (at least one CAN frame without fail must have been received) 0 _B NO_SYNC , SWK function not working or not synchronous to CAN bus 1 _B SYNC , Valid CAN frame received, SWK function is synchronous to CAN bus
WUP	5	rc	Wake-up Pattern Detection 0 _B NO_WUP , No WUP 1 _B WUP_DETECTED , WUP detected
WUF	4	rc	SWK Wake-up Frame Detection 0 _B NO_WUF , No WUF 1 _B WUF_DETECTED , WUF detected
CANSIL	3	r	CAN Silent Time during SWK operation 0 _B NO_SIL , tsilence not exceeded 1 _B SIL_EXCEEDED , set if tsilence is exceeded.
SWK_SET	2	r	Selective Wake Activity 0 _B INACTIVE , Selective Wake is not active 1 _B ACTIVE , Selective Wake is activated
RES	1:0	r	Reserved, always reads as 0

Table 105 Reset of [SWK_STAT](#)

Register Reset Type	Reset Values	Reset Short Name	Reset Mode	Note
POR/Soft reset	0000 0000 0000 0000 _B			
Restart	0000 0000 0xxx xx00 _B			

Note: *SWK_SET* is set to flag that the selective wake functionality is activated (*SYSEERR* = 0, *CFG_VAL* = 1, *CAN_2* = 1). The selective wake function is activated via a CAN mode change, except if *CAN* = '100'.

Serial Peripheral Interface

Selective Wake ECNT Status

SWK_ECNT_STAT

Selective Wake ECNT Status

(110 0001_B)

Reset Value: see [Table 106](#)

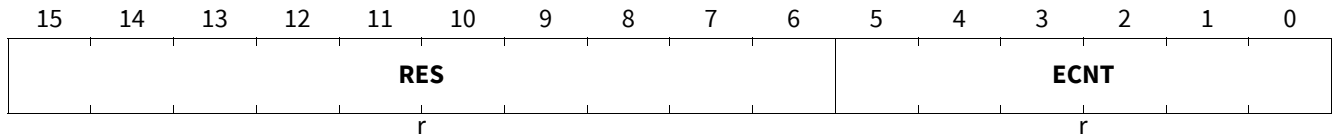

Field	Bits	Type	Description
RES	15:6	r	Reserved, always reads as 0
ECNT	5:0	r	SWK CAN Frame Error Counter 00 0000 _B NO_ERR , No Frame Error 01 1111 _B 31 , 31 Frame Errors have been counted 10 0000 _B OVERFLOW , Error counter overflow - SWK function will be disabled

Table 106 Reset of [SWK_ECNT_STAT](#)

Register Reset Type	Reset Values	Reset Short Name	Reset Mode	Note
POR/Soft reset	0000 0000 0000 0000 _B			
Restart	0000 0000 00xx xxxx _B			

Note: If a frame has been received that is valid according to ISO11898-2:2016 and the counter is not zero, then the counter shall be decremented. If the counter has reached a value of 32, the following actions shall be performed: Selective Wake function shall be disabled, SYSERR shall be set and CAN wake capable function shall be enabled, which leads to a wake with the next WUP.

Serial Peripheral Interface

Selective Wake CDR Status

SWK_CDR_STAT

Selective Wake CDR Status

(110 0011_B)

Reset Value: see [Table 107](#)

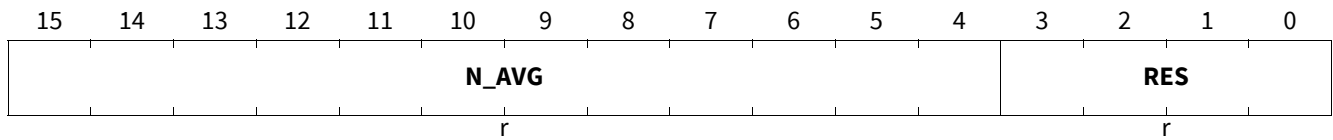

Field	Bits	Type	Description
N_AVG	15:4	r	Output Value from Filter Block N_AVG is representing the integer part of the number of selected input clock frequency per CAN bus bit.
RES	3:0	r	Reserved, always reads as 0

Table 107 Reset of [SWK_CDR_STAT](#)

Register Reset Type	Reset Values	Reset Short Name	Reset Mode	Note
POR/Soft reset	1010 0000 0000 0000 _B			
Restart	xxxx xxxx xxxx 0000 _B			

Serial Peripheral Interface

14.6.4 Family and product information register

Family and Product Identification Register

FAM_PROD_STAT

Family and Product Identification Register (111 0000_B)

Reset Value: see [Table 108](#)

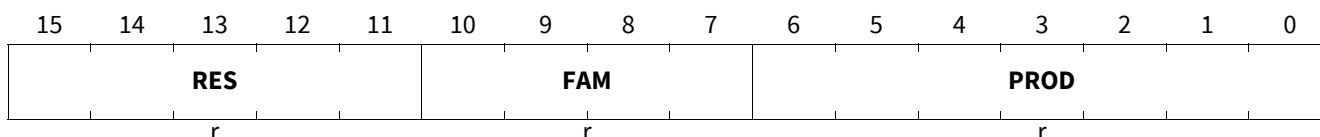

Field	Bits	Type	Description
RES	15:11	r	Reserved, always reads as 0
FAM	10:7	r	Device Family Identifier 1000 _B , DC Motor System IC
PROD	6:0	r	Device Product Identifier 000 0000 _B TLE9562-3QX/QX , TLE9562-3QX/-3QXJ/QX 000 0001 _B TLE9561-3QX/QX , TLE9561-3QX/-3QXJ/QX 000 0010 _B TLE9563-3QX , TLE9563-3QX 000 0011 _B TLE9564QX , TLE9564QX, TLE9185QX 001 0000 _B TLE9562-3QX V33 , TLE9562-3QX V33 001 0010 _B TLE9563-3QX V33 , TLE9563-3QX V33 001 0011 _B TLE9564QX V33 , TLE9564QX V33, TLE9185QX V33 001 1000 _B TLE9560QX , TLE9560-3QX/-3QXJ

Table 108 Reset of FAM_PROD_STAT

Register Reset Type	Reset Values	Reset Short Name	Reset Mode	Note
POR/Soft reset	0000 0100 0000 0000 _B			
Restart	0000 0100 0000 0000 _B			

14.7 Electrical Characteristics

Table 109 Electrical Characteristics: Power Stage

$V_{SINT} = 5.5\text{ V to } 28\text{ V}$, $T_j = -40^\circ\text{C to } +150^\circ\text{C}$, all voltages with respect to ground, positive current flowing into pin (unless otherwise specified)

Parameter	Symbol	Values			Unit	Note or Test Condition	Number
		Min.	Typ.	Max.			
SPI frequency							
Maximum SPI frequency	$f_{SPI,max}$	–	–	6.0	MHz	¹⁾ $V_{CC1} > 3\text{ V}$	P_14.7.1
SPI Interface; Logic Inputs SDI, CLK and CSN							
H-input Voltage Threshold	V_{IH}	–	–	$0.7 \times V_{CC1}$	V	–	P_14.7.2
L-input Voltage Threshold	V_{IL}	$0.3 \times V_{CC1}$	–	–	V	–	P_14.7.3
Hysteresis of input Voltage	V_{IHY}	–	$0.12 \times V_{CC1}$	–	V	¹⁾	P_14.7.4
Pull-up Resistance at pin CSN	R_{ICSN}	20	40	80	k Ω	–	P_14.7.5
Pull-down Resistance at pin SDI and CLK	$R_{ICLK/SDI}$	20	40	80	k Ω	$V_{SDI/CLK} = 0.2 \times V_{CC1}$	P_14.7.6
Input Capacitance at pin CSN, SDI or CLK	C_I	–	10	–	pF	¹⁾ $V_{CSN}, V_{SDI}, V_{CLK} = V_{CC1}$	P_14.7.7
Logic Output SDO							
H-output Voltage Level	V_{SDOH}	$0.8 \times V_{CC1}$	–	–	V	$I_{DOH} = -2\text{ mA}$	P_14.7.8
L-output Voltage Level	V_{SDOL}	–	–	$0.2 \times V_{CC1}$	V	$I_{DOL} = 2\text{ mA}$	P_14.7.9
‘Tri-state Input Capacitance	C_{SDO}	–	10	15	pF	¹⁾ $V_{CSN}, V_{SDI}, V_{CLK} = V_{CC1}$	P_14.7.11
Tri-state Leakage Current	I_{SDOLK}	–10	–	10	μA	¹⁾ $V_{CSN} = V_{CC1}$, $0\text{V} < V_{SDO} < V_{CC1}$	P_14.7.38
Data Input Timing¹⁾							
Clock Period	t_{pCLK}	160	–	–	ns	–	P_14.7.12
Clock HIGH Time	t_{CLKH}	70	–	–	ns	–	P_14.7.13
Clock LOW Time	t_{CLKL}	70	–	–	ns	–	P_14.7.14
Clock LOW before CSN LOW	t_{bef}	70	–	–	ns	–	P_14.7.15
CSN Setup Time	t_{lead}	160	–	–	ns	–	P_14.7.16
CLK Setup Time	t_{lag}	160	–	–	ns	–	P_14.7.17
Clock LOW after CSN HIGH	t_{beh}	70	–	–	ns	–	P_14.7.18
SDI Setup Time	t_{DISU}	60	–	–	ns	–	P_14.7.19
SDI Hold Time	t_{DIHO}	40	–	–	ns	–	P_14.7.20

Serial Peripheral Interface

Table 109 Electrical Characteristics: Power Stage (cont'd)

$V_{SINT} = 5.5\text{ V to }28\text{ V}$, $T_j = -40^\circ\text{C to }+150^\circ\text{C}$, all voltages with respect to ground, positive current flowing into pin (unless otherwise specified)

Parameter	Symbol	Values			Unit	Note or Test Condition	Number
		Min.	Typ.	Max.			
Input Signal Rise Time at pin SDI, CLK and CSN	t_{rIN}	-	-	20	ns	-	P_14.7.21
Input Signal Fall Time at pin SDI, CLK and CSN	t_{fIN}	-	-	20	ns	-	P_14.7.22
Delay Time for Mode Changes ²⁾	$t_{Del,Mode}$	-	-	5	μs	³⁾	P_14.7.23
CSN HIGH Time	$t_{CSN(high)}$	3	-	-	μs	-	P_14.7.24

Data Output Timing¹⁾

SDO Rise Time	t_{rSDO}	-	30	40	ns	$C_L = 50\text{ pF}$, $0.2 \times V_{CC1}$ to $0.8 \times V_{CC1}$	P_14.7.25
SDO Fall Time	t_{fSDO}	-	30	40	ns	$C_L = 50\text{ pF}$, $0.8 \times V_{CC1}$ to $0.2 \times V_{CC1}$	P_14.7.26
SDO Enable Time	t_{ENSDO}	-	-	40	ns	LOW impedance	P_14.7.27
SDO Disable Time	t_{DISSDO}	-	-	40	ns	HIGH impedance	P_14.7.28
SDO Valid Time	t_{VASDO}	-	-	40	ns	$C_L = 50\text{ pF}$	P_14.7.29

- 1) Not subject to production test; specified by design.
- 2) Applies to all mode changes triggered via SPI commands.
- 3) Guaranteed by design.

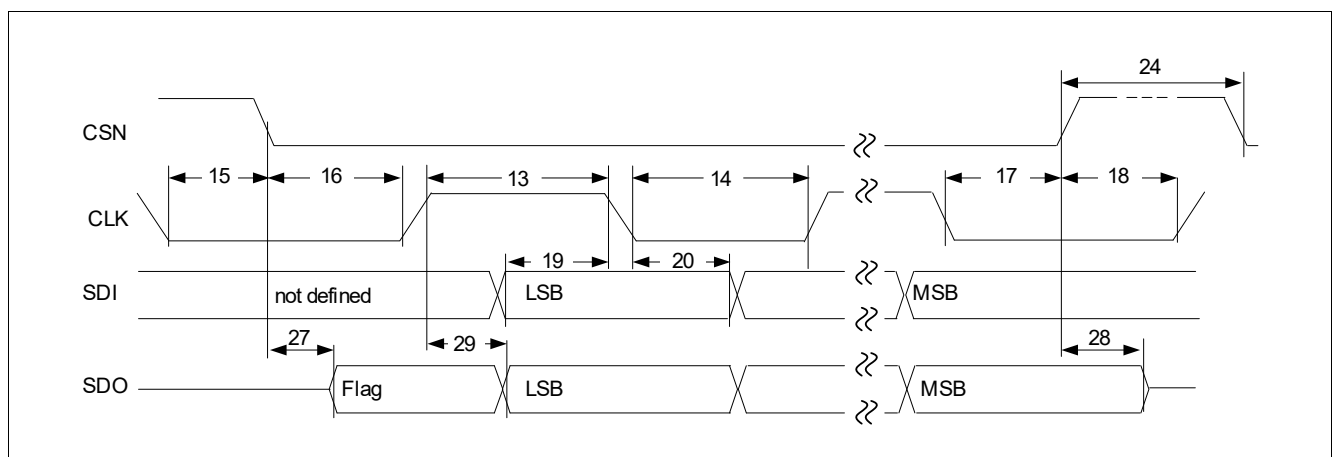

Figure 94 SPI Timing Diagram

Note: Numbers in drawing correlate with the last 2 digits of the Number field in the Electrical Characteristics table.

Application Information

15 Application Information

Note: The following information is given as a hint for the implementation of the device only and shall not be regarded as a description or warranty of a certain functionality, condition or quality of the device.

15.1 Application Diagrams

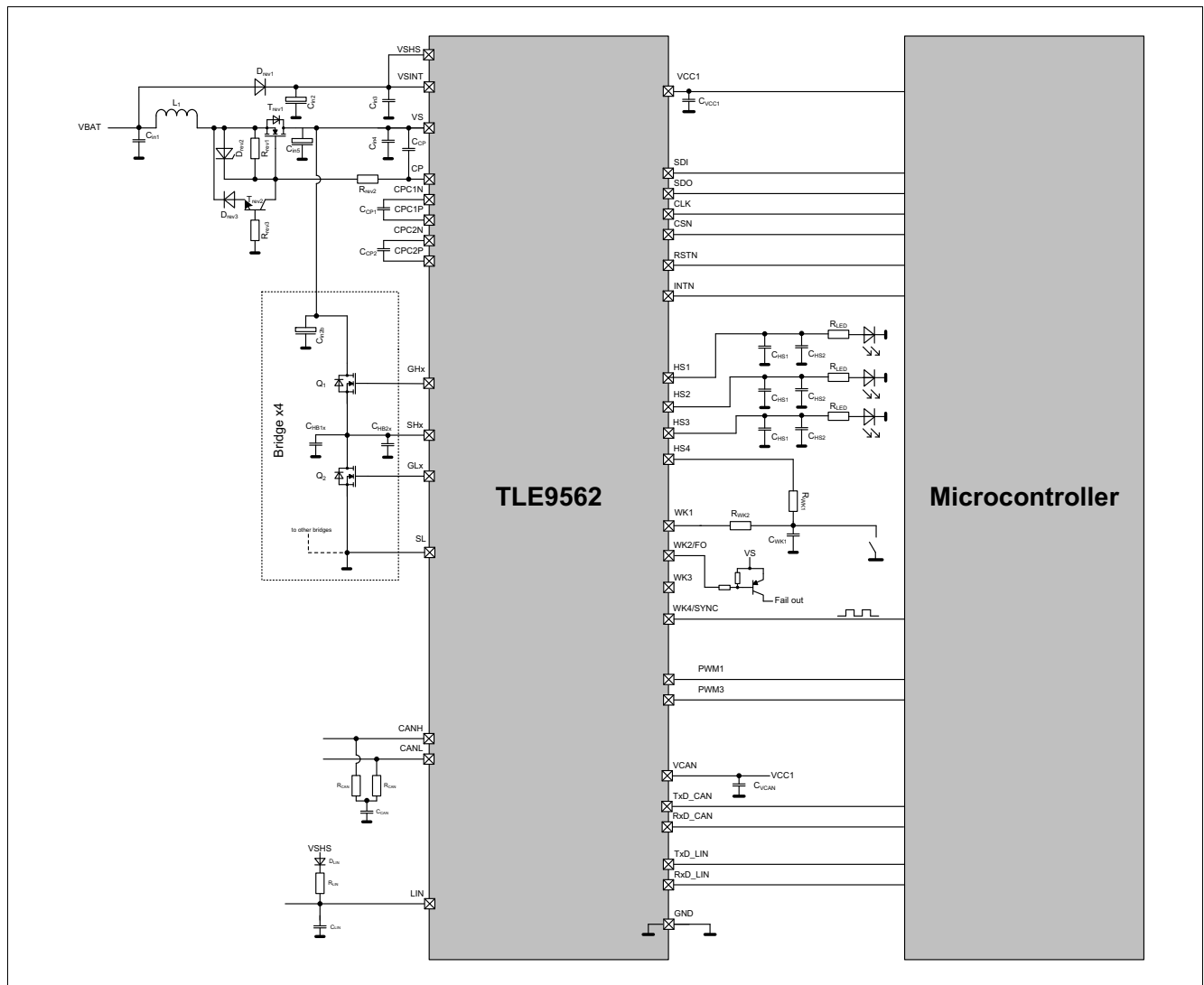

Figure 95 TLE9562-3QX Application Diagram

Note: This is a very simplified example of an application circuit. The function must be always verified in the real application.

Application Information

Table 110 Bill of Material

Ref.	Typical Value	Purpose / Comment
Capacitances		
C _{in1}	100 nF ±20% ceramic	Input filter battery capacitor for optimum EMC behavior
C _{in2}	100 µF ±20%, 50 V Electrolytic	Buffering capacitor to cut off battery spikes, depending on the application
C _{in2b}	470 µF ±20%, 50 V Electrolytic	Buffering capacitor for bridges. Cut off battery spikes, depending on the application
C _{in3}	100 nF ±20%, 50 V Ceramic	Input capacitor
C _{in4}	100 nF ±20%, 50 V Ceramic	Input capacitor
C _{in5}	470 µF ±20%, 50 V Electrolytic	Buffering capacitor for bridges. Cut off battery spikes, depending on the application
C _{CP}	470 nF ±20%, 50 V Ceramic	Charge-Pump buffering capacitor
C _{CP1} / C _{CP2}	220 nF ±20%, 50 V Ceramic	Charge-Pump flying capacitor to be placed as closed as possible to the device pins, in order to minimize the length of the PCB tracks
C _{CAN}	4.7 nF / OEM dependent	Split termination stability
C _{LIN}	1 nF / OEM dependent	LIN master termination
C _{VCC1}	2.2 µF ±20%, 16 V	Blocking capacitor. Low ESR. Minimum 1 µF effective capacitance
C _{VCAN}	1 µF ... 4.7 µF	Input filter CAN supply. The capacitor must be placed close to the VCAN pin. For optimum EMC and CAN FD performances, the capacitor has to be ≥ 2.2 µF
C _{HB1x}	10 nF ±20%, 50 V Ceramic	Half-Bridge EME (electromagnetic emission) and ESD suppression filter to be placed close to the connector. Other capacitance values might be needed depending on application
C _{HB2x}	560 pF ±20%, 50 V Ceramic	Optional filter for EMI immunity to be placed close to the SHx pin (PCB footprints highly recommended). Other capacitance values might be needed depending on application
C _{HS1}	47 pF / OEM dependent	Only required on case of off-board connection to optimize EMC behavior, place close to pin
C _{HS2}	33 nF / OEM dependent	As required by application, mandatory protection for off-board connection
C _{WK1} / C _{WK2}	47 nF / OEM dependent	Spike filtering, as required by application, mandatory protection for off-board connections
Inductances		
L ₁	4 µH ... 6 µH	Input filter for power stage - consider high current rating (application dependent)

Application Information

Table 110 Bill of Material (cont'd)

Ref.	Typical Value	Purpose / Comment
Resistances		
R _{REV1}	100 kΩ ±5%	Other values needed depending on application
R _{REV2}	10 kΩ ±5%	Device protection against reverse battery
R _{REV3}	10 kΩ ±5%	
R _{CAN}	60 Ω / OEM dependent	CAN bus termination
R _{LIN}	1 k ±5%	LIN master termination
R _{LED}	1 k	Limit LED-current
R _{WK1} / R _{WK2} / R _{WK3} / R _{WK4}	10 kΩ ±5%	
Active Components		
D _{REV1}	RR268MM600	Reverse polarity protection
D _{REV2}	BZX84C16	Gate protection. Limit V _{GS}
D _{REV3}	BAS21	
T _{REV1}	IPZ40N04S5L-2R8	Reverse battery protection, N-MOS
T _{REV2}	BC846	
Q ₁ / Q ₂	IPZ40N04S5-5R4	Main power switches
D _{LIN}	BAS70	Requested by LIN standard; reverse polarity protection of network

Application Information

15.2 ESD Tests

15.2.1 ESD according to IEC61000-4-2

Tests for ESD robustness according to IEC61000-4-2 “GUN test” (150 pF, 330 Ω) have been performed. The results and test condition are available in a test report. The values for the test are listed below.

Table 111 ESD “GUN test”¹⁾²⁾

Performed Test	Result	Unit	Remarks
ESD at pin CANH, CANL, LIN, HSx, VS, VSINT, VSHS, WKx versus GND	> 6	kV	positive pulse
ESD at pin CANH, CANL, LIN, HSx, VS, VSINT, VSHS, WKx versus GND	< -6	kV	negative pulse

- 1) ESD susceptibility “ESD GUN” according to EMC 1.3 Test specification, Section 4.3 (IEC 61000-4-2). Tested by external test house (IBEE Zwickau, EMC Test report Nr. 20.12.20).
- 2) ESD Test “Gun Test” is specified with external components for pins VS, VSINT, VSHS, WKx, HSx. See the application diagram in [Chapter 15.1](#) for more information.

15.2.2 ESD according to SAE J2962

Tests for ESD robustness according to SAE J2962 have been performed.

Table 112 ESD according to SAE J2962

Performed Test	Result	Unit	Remarks
ESD at pin CANH, CANL, LIN versus GND	± 4	kV	Unpowered, contact discharge
ESD at pin CANH, CANL versus GND	± 8	kV	Powered, contact discharge
ESD at pin LIN versus GND	± 8	kV	¹⁾ Powered, contact discharge
ESD at pin CANH, CANL versus GND	± 15	kV	Powered, air discharge
ESD at pin LIN versus GND	± 25	kV	¹⁾ Powered, air discharge

- 1) For ESD pulses ≤ - 6 kV, VCC1 undervoltage may be detected.

15.3 Thermal Behavior of Package

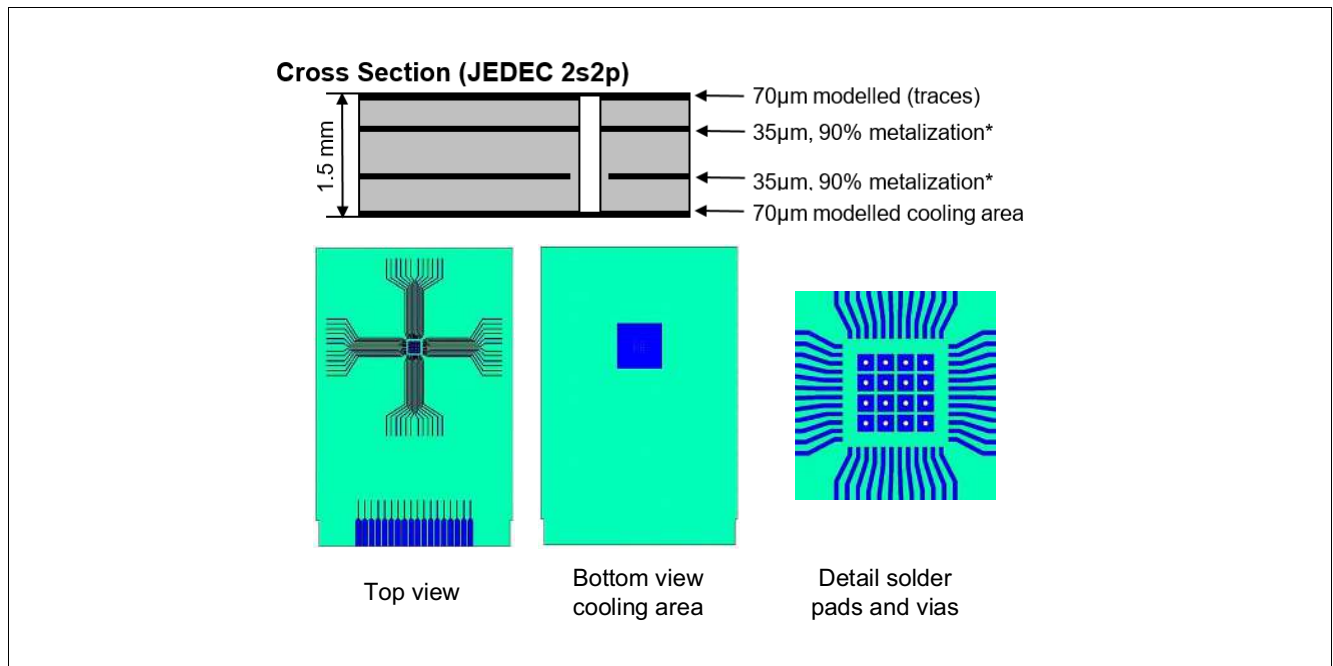

Figure 96 Board Setup

Board setup is defined according JESD 51-2, -5, -7.

Board: $76.2 \times 114.3 \times 1.5 \text{ mm}^3$ with 2 inner copper layers (35 μm thick), with thermal via array under the exposed pad contacting the first inner copper layer and 300 mm² cooling area on the bottom layer (70 μm).

15.4 Further Application Information

- The VS pin supplies the bridge driver and the charge pump, and is the sense pin for the high-side MOSFETs drain voltage. It is therefore highly recommended to connect a 100 nF / 50V ceramic by-pass capacitor as close as possible to the VS pin with a short PCB trace to GND.
- Please contact us for information regarding the FMEA pin
- For further information you may contact <http://www.infineon.com/>

Revision History

17 Revision History

Revision	Date	Changes
1.0	2021-01-21	First release

Trademarks

All referenced product or service names and trademarks are the property of their respective owners.

Edition 2021-01-21

Published by

Infineon Technologies AG

81726 Munich, Germany

© 2021 Infineon Technologies AG.

All Rights Reserved.

Do you have a question about any aspect of this document?

Email: erratum@infineon.com

IMPORTANT NOTICE

The information given in this document shall in no event be regarded as a guarantee of conditions or characteristics ("Beschaffenhheitsgarantie").

With respect to any examples, hints or any typical values stated herein and/or any information regarding the application of the product, Infineon Technologies hereby disclaims any and all warranties and liabilities of any kind, including without limitation warranties of non-infringement of intellectual property rights of any third party.

In addition, any information given in this document is subject to customer's compliance with its obligations stated in this document and any applicable legal requirements, norms and standards concerning customer's products and any use of the product of Infineon Technologies in customer's applications.

The data contained in this document is exclusively intended for technically trained staff. It is the responsibility of customer's technical departments to evaluate the suitability of the product for the intended application and the completeness of the product information given in this document with respect to such application.

For further information on technology, delivery terms and conditions and prices, please contact the nearest Infineon Technologies Office (www.infineon.com).

WARNINGS

Due to technical requirements products may contain dangerous substances. For information on the types in question please contact your nearest Infineon Technologies office.

Except as otherwise explicitly approved by Infineon Technologies in a written document signed by authorized representatives of Infineon Technologies, Infineon Technologies' products may not be used in any applications where a failure of the product or any consequences of the use thereof can reasonably be expected to result in personal injury.