

F
E
D
C
B
A

1 2 3 4 5 6 7 8 9

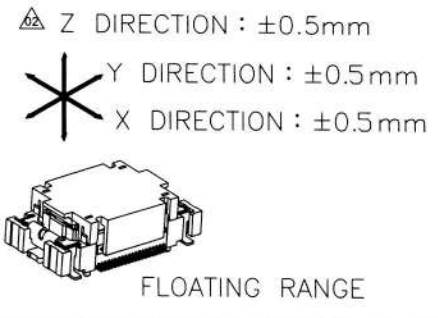
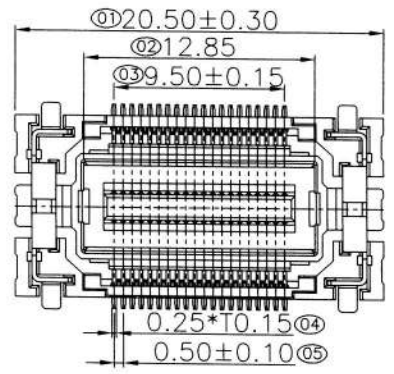

| REV. | LOCAS. | DESCRIPTION | DATE | DRAWN |
|------|--------|-----------------------------------|------------|-------|
| 01 | NEW | BATCH PRODUCTION INITIAL RELEASE. | 2021.08.25 | 劉先平 |
| 02 | △ | 产品增加浮动量说明 | 2022.09.26 | 劉先平 |

Specifications
 Current Rating:0.4Amp
 Insulation Resistance:500M Min.
 Dielectric Withstanding Voltage:250VAC/60S
 Contact Resistance:100m Max.
 Operating Temperature:-40°C to +105°C
 Materials
 Contact Material:Phosphor Bronze
 Insulator Material:High Temperature Thermoplastic, UL 94V-0 LCP or the equivalent material
 ☆ All materials must meet GREENCONN hazardous substances control standards.
 "★": Critical Characteristics, indicates product characteristics, functionalities, and manufacturing processes regarding to customer's specifications
 "☆": Safety Features indicates product characteristics, functionalities, and manufacturing processes complying to legal regulations stated by local government

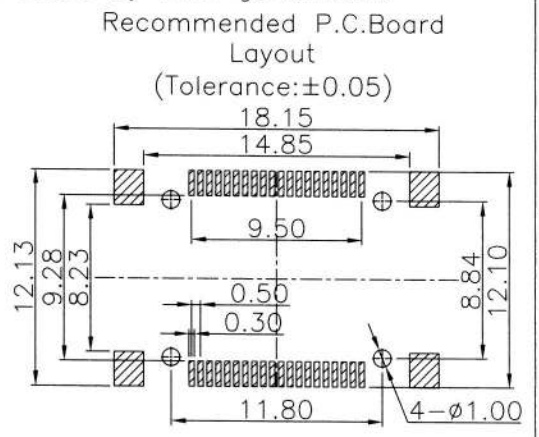
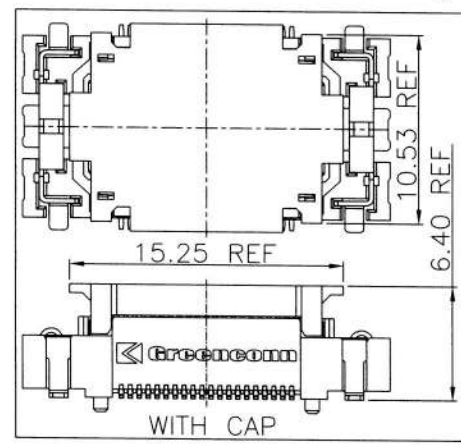
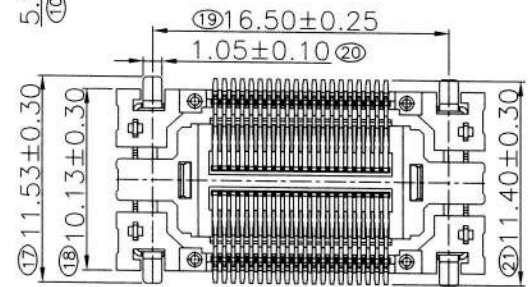
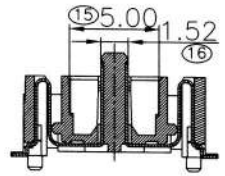
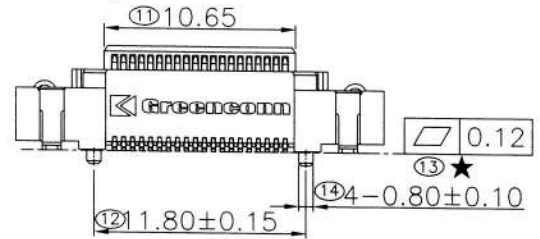
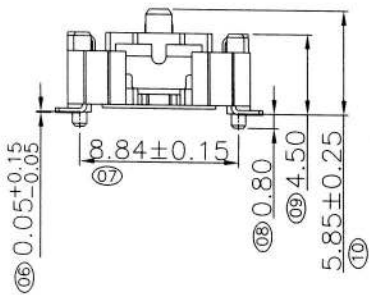

Ordering Information

G BAC229 - XX XX B 001 C 1 N X

No. of Pins per Row: 20
 Standard Plating: 02=Gold Flash
 Color: 1=Black
 Standard Packing: F=CAP+Tape&Reel

| Greenconn P/N | Customer | Remarks |
|----------------------|----------|----------------------|
| GBAC229-2002B001C1NF | XXX | Automotive connector |

3RD.ANG PROJ.

 PAGE. 1/1

| GENERAL TOLERANCE | |
|-------------------|-----------|
| X.*±3.0" | X.±0.25 |
| .X"±2.0" | .X±0.20 |
| .XX"±1.0" | .XX±0.13 |
| .XXX"±0.5" | .XXX±0.08 |

DESIGNED: 劉先平 DATE: 2022.09.26
 CHECKED: 木木木木 DATE: 2022.9.26
 APPROVED: 王王王 DATE: 2022.9.26

DWG. NO. GBAC229-CB1CN
 PART NO. GBAC229-XXXXB001C1NX

TITLE:
 0.5mm PITCH BTB FLOATING CONNECTOR

1 2 3 4 5 6 7 8 9

F
E
D
C
B
A