

---

## Si860xI2C EVALUATION BOARD USER'S GUIDE

---

### 1. Introduction

The Si860xI2C evaluation board allows designers to evaluate Skyworks' family of ultra-low-power I<sup>2</sup>C isolators. These isolators are CMOS devices employing RF coupler technology to transmit digital information across an isolation barrier. Very high speed operation at low power levels is achieved. These products are based on Skyworks' proprietary RF isolation technology and offer shorter propagation delays, lower power consumption, improved noise immunity, smaller installed size, and more stable operation with temperature and age versus opto couplers. The Si860x isolator series consists of single-package galvanic isolation solutions for I<sup>2</sup>C, SMBus, and other digital power supply communications, including those for bus power management. For more information, refer to the respective family data sheets.

A summary of the benefits provided by the Skyworks Si86xx digital isolator family includes the following:

- Si86xx Digital Isolators
  - 5.0 kV, 3.75 kV, and 2.5 kV isolation ratings
  - UL, CSA, CQC, and VDE certifications
  - DC to 150 Mbps
  - 2.5 to 5.5 V VDD supply range
  - Fail-safe operating mode(s)
  - -40 to 125 °C temperature range
  - 10 ns max propagation delay
  - <1.5 mA/channel @ 1 Mbps
  - <1.5 ns pulse width distortion
  - Very low EMI
  - Up to 50 V/m electric field immunity
  - >1000 A/m magnetic field immunity
  - >30 kV/μs CMTI
  - 4 kV HBM ESD immunity
- Si860x I<sup>2</sup>C-Compatible Isolators
  - Bidirectional I<sup>2</sup>C channels
  - Supports I<sup>2</sup>C clocks up to 1.7 MHz
  - 3 to 5.5 V VDD supply range
  - Open drain outputs with 35 mA sink current
- Packaging and Isolation Rating Options (kVrms) for Si860x devices
  - NB SOIC-8 (2.5 kV, 3.75 kV)
  - NB SOIC-16 (2.5 kV, 3.75 kV)
  - WB SOIC-16 (5 kV)
  - RoHS compliant

# Si860xI2C-EVB UG

## 2. Kit Contents

The Si860xI2C Evaluation Kit contains the following items:

- Si860xI2C-EVB evaluation board shown in Figure 1.
- Si8600, Si8602, and Si8605 I<sup>2</sup>C digital isolators installed on the evaluation board.

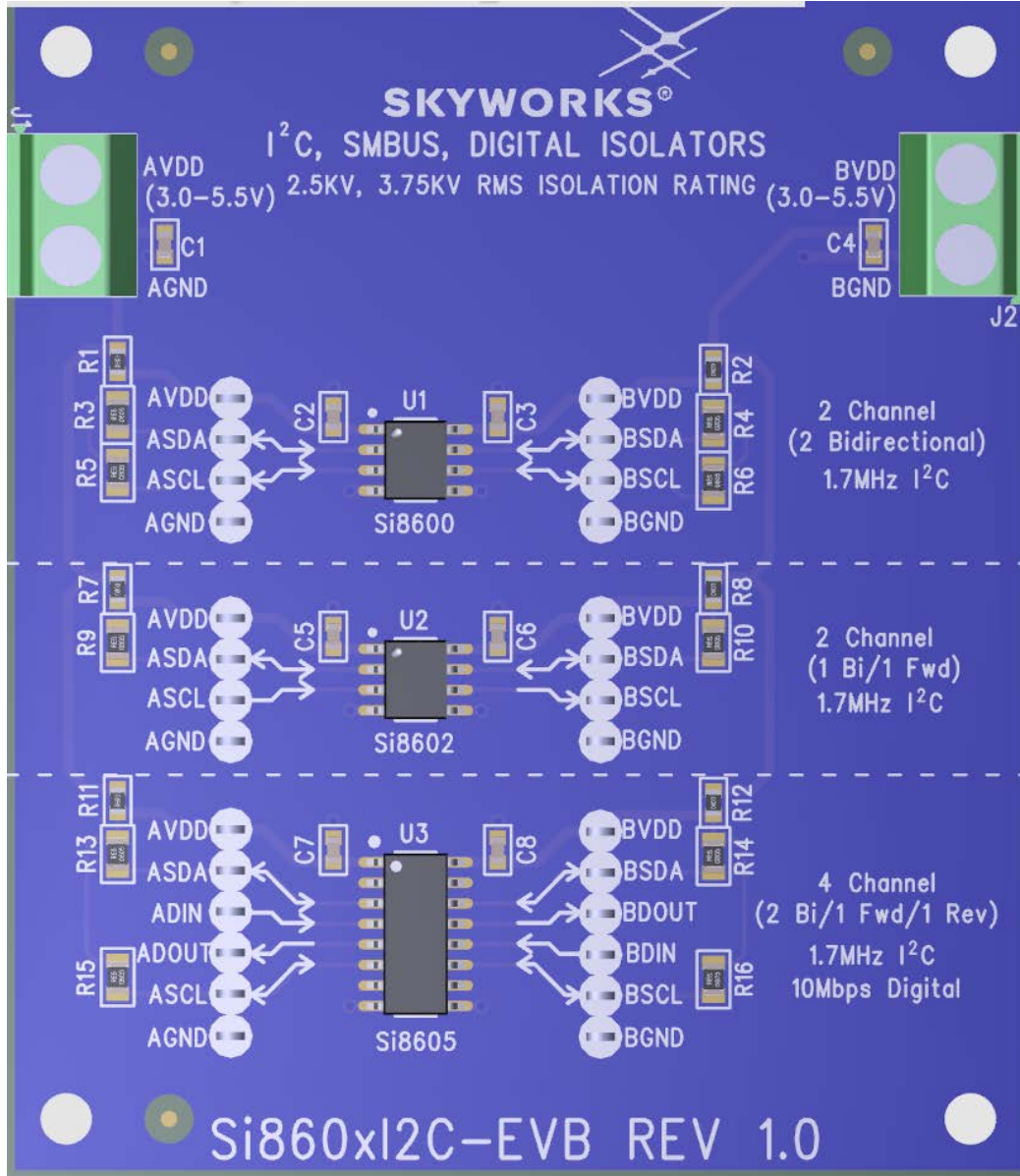

Figure 1. Si860xI2C Evaluation Board Overview

## 3. Hardware Overview and Setup

The Si860xI2C evaluation board comes populated with an Si8600 (isolated I<sup>2</sup>C, two bidirectional), Si8602 (isolated I<sup>2</sup>C, one bidirectional), and Si8605 (I<sup>2</sup>C isolator, two bidirectional, two unidirectional). The board is designed to be powered from two separate 5 V supplies (500 mA) that power all the isolators on the boards. Power is applied to the board before evaluating any isolated channel. Power is applied to the Si860xI2C-EVB by connecting 5 V supplies to the terminal blocks (AVDD and AGND, BVDD and BGND) found near the top of the board. Supplies as low as 3.0 V and as high as 5.5 V can be used. Figure 2 provides a silkscreen overview of the board.

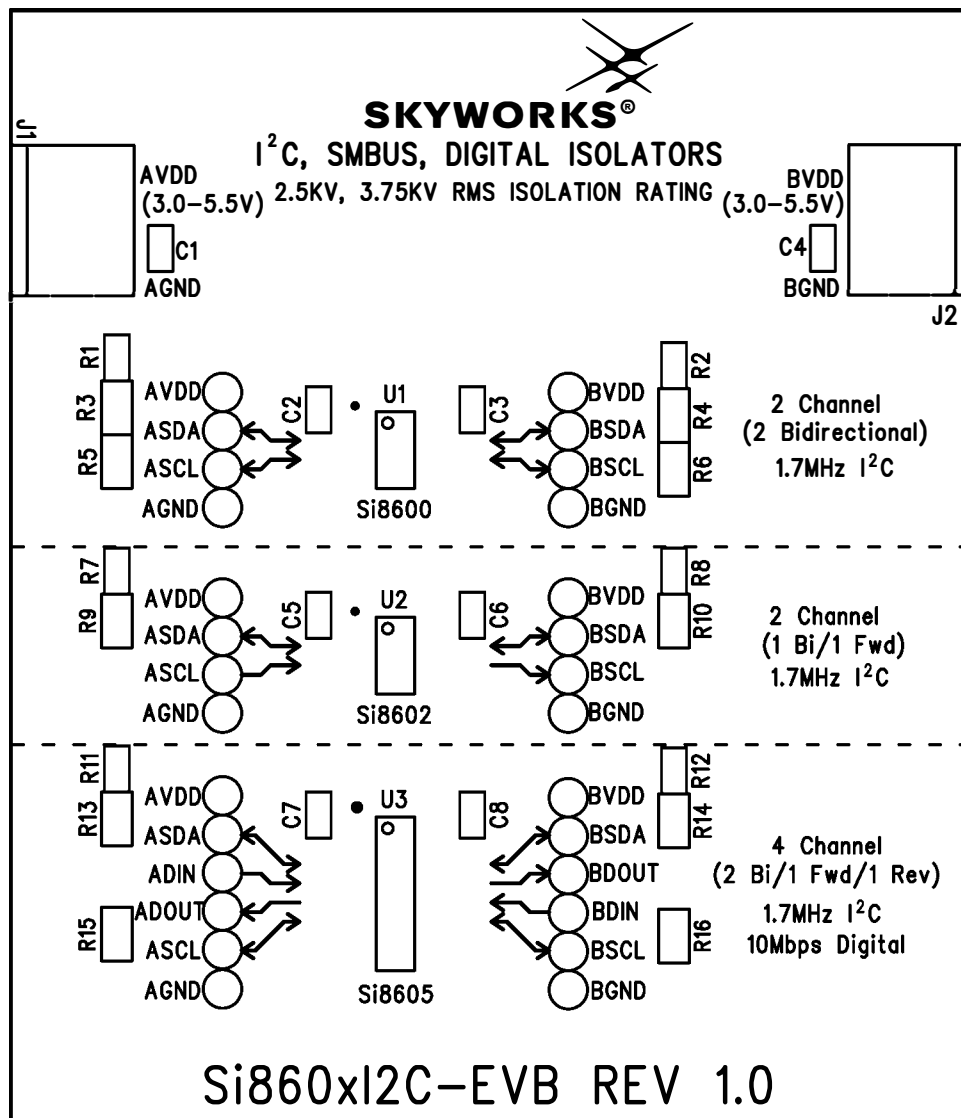

Figure 2. Si860xI2C Evaluation Board Silkscreen

# Si860xI2C-EVB UG

## 3.1. I<sup>2</sup>C Isolator Considerations

The Si8600, Si8602, and Si8605 each have one or two 1.7 MHz I<sup>2</sup>C channels that are bidirectional. After power has been supplied to the EVB, connect an I<sup>2</sup>C controller to the desired input channel. The Si860x I<sup>2</sup>C channels have 3 kΩ pull-up resistors already installed. If these resistors are redundant with the controller, the user should remove the redundant pull-up resistors to accommodate adequate drive current for the test being performed.

Figure 3 illustrates Side A pulling down, with Side B following, for the Si8600 device. An I<sup>2</sup>C pin of a microcontroller asserted a logic low at Side A, which pulls the normally high signal low. Both Side A and Side B were powered with 5 V. Channel 4 (green) is Side A, and Channel 3 (pink) is Side B.

Figure 4 illustrates Side B pulling up, with Side A following, for the same Si8600 device. An I<sup>2</sup>C pin of a microcontroller was deasserted at Side B, and the 3 kΩ pull-up resistors on each side pulls the signal high.



Figure 3. Side A Pulling Down on Si8600 I<sup>2</sup>C Channel

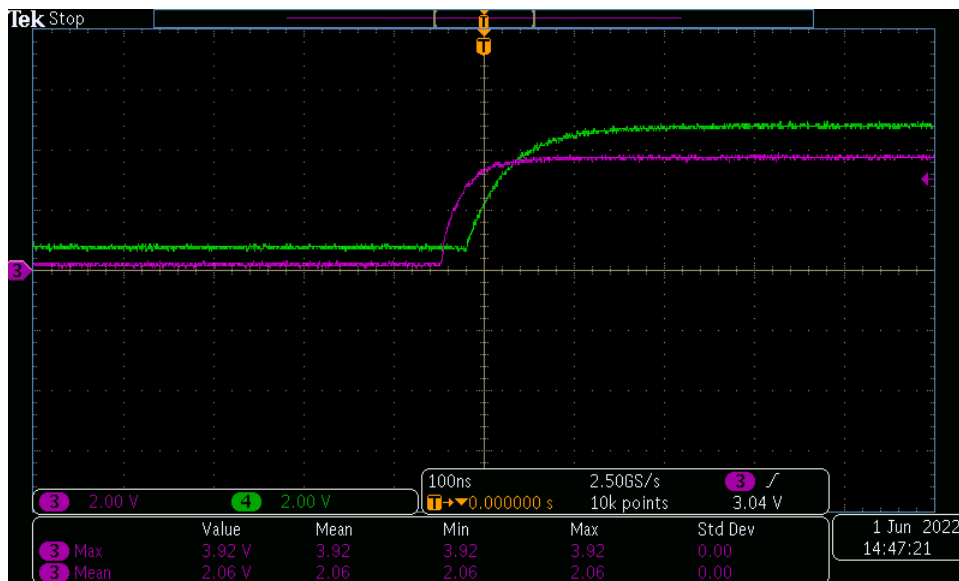

Figure 4. Side B Pulling Up on Si8600 I<sup>2</sup>C Channel

## 3.2. Digital Isolator Considerations

After power has been supplied to the board, connect a digital input signal (5 V<sub>peak</sub> max, with desired clock frequency up to 10 Mbps) to the desired digital input channel (Si8602 and Si8605). To view the isolated channel's data transmission, connect a scope probe to the digital output channel of interest. The board can be used to measure propagation delay, pulse-width distortion, channel-channel matching, pulse-width skew, and various other parameters.

The nominal output impedance of an isolator driver channel is approximately 50 Ω, ±40%, which is a combination of the values of the on-chip series termination resistor and the channel resistance of the output driver FET. When driving loads where transmission line effects will be a factor, output pins should be terminated with 50 Ω controlled impedance PCB traces.

Figure 5 illustrates the Si8605 transmitting a 500 kHz, 4V<sub>peak</sub> digital signal from side A to side B. AVDD and BVDD were powered with 5 V power supplies. Channel 1 (yellow) illustrates the input waveform, and Channel 3 (pink) illustrates the output waveform.

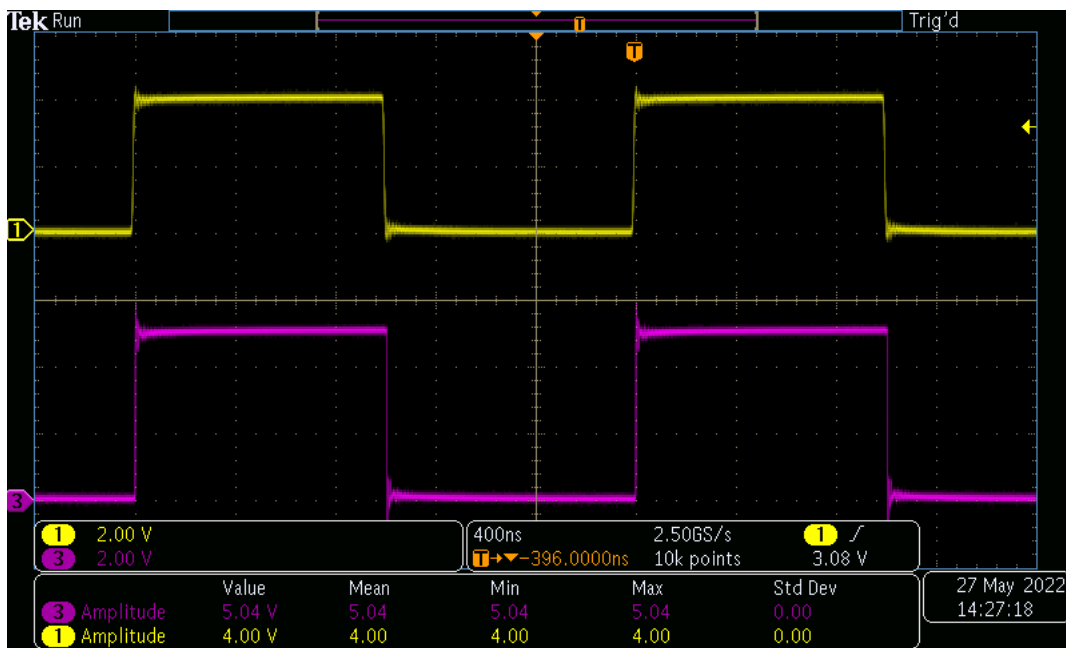

Figure 5. 500 kHz Square Wave on Si8605 Digital Channel

# Si860xI2C-EVB UG

## 4. Si860xI2C Evaluation Board Schematic

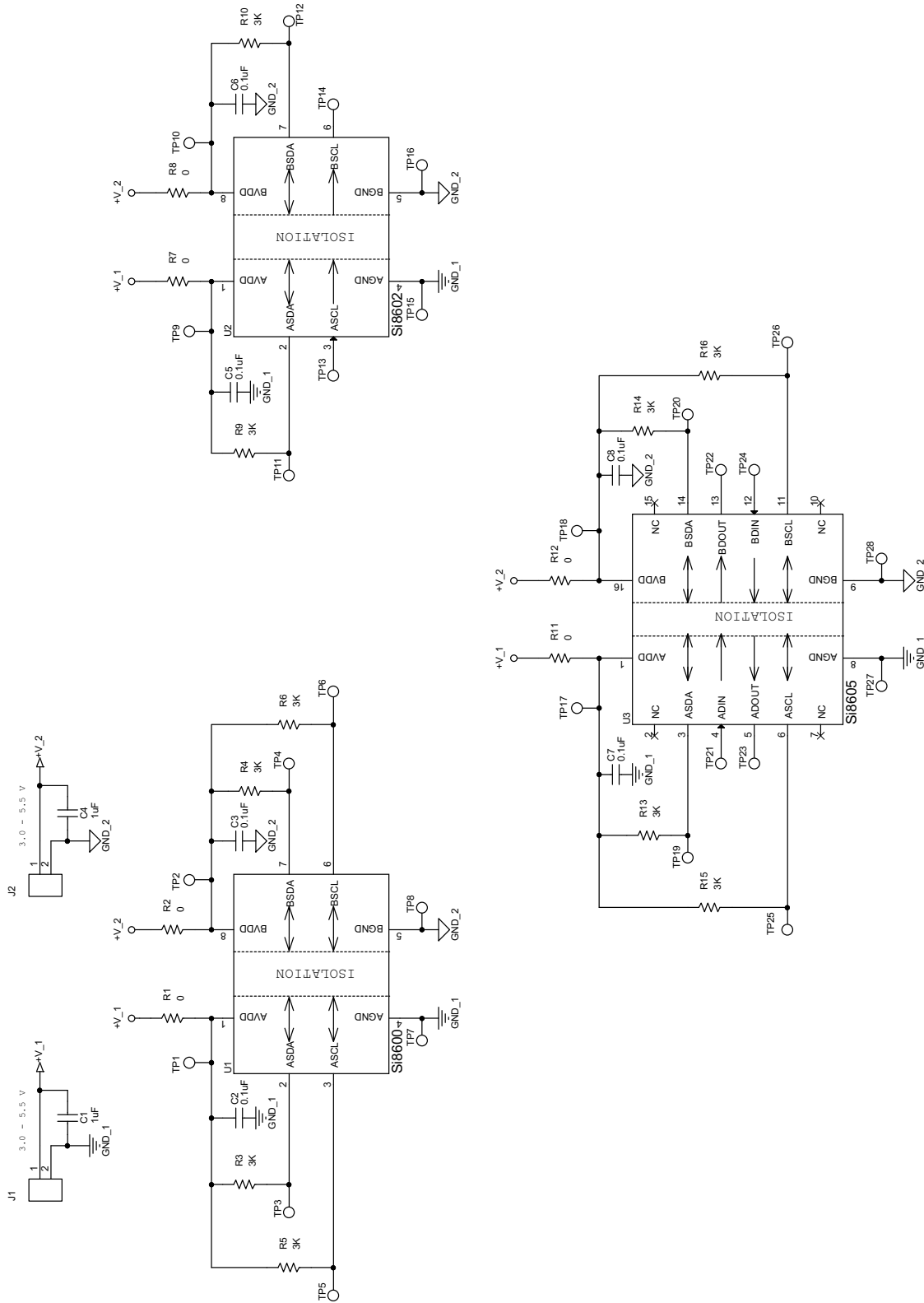

Figure 6. Si860xI2C Evaluation Board Schematic

## 5. Bill of Materials

**Table 1. Si86xxISO Evaluation Board Bill of Materials**

Item	Qty	Reference	Part Number	Mfr	Description
1	2	C1, C4	C0603X7R100-105K	Venkel	1 $\mu$ F $\pm$ 10% 10 V Ceramic Capacitor, X7R, 0603, RoHS
2	6	C2, C3, C5, C6, C7, C8	C0603X7R100-104K	Venkel	0.1 $\mu$ F $\pm$ 10% 10 V Ceramic Capacitor, X7R, 0603/0603L, RoHS
3	2	J1, J2	1729018	Phoenix Contact	Two-Position Terminal Block, 0.197", Through Hole, RoHS
4	1	PCB1	Si860xI2C-EVB REV 1.0	Skyworks	Bare Si860xI2C-EVB PCB, RoHS
5	6	R1, R2, R7, R8, R11, R12	CR0603-16W-000	Venkel	0 $\Omega$ Jumper 1/16 W Chip Resistor, 0603, Thick Film, RoHS
6	10	R3, R4, R5, R6, R9, R10, R13, R14, R15, R16	CR0805-10W-3001F	Venkel	3 k $\Omega$ $\pm$ 1% 1/10 W Chip Resistor, 0805, Thick Film, RoHS
7	28	TP1 – TP28	5002	Keystone	White PC Test Point, 0.040" Hole Diameter Mounting Type, RoHS
8	1	U1	Si8600AB-B-IS	Skyworks	2.5 kV I <sup>2</sup> C Isolator IC, Two Bidirectional, NB SOIC-8, RoHS
9	1	U2	Si8602AB-B-IS	Skyworks	2.5 kV I <sup>2</sup> C Isolator IC, One Bidirectional, One Unidirectional, NB SOIC-8, RoHS
10	1	U3	Si8605AB-B-IS1	Skyworks	2.5 kV I <sup>2</sup> C Isolator IC, Two Bidirectional, Two Unidirectional, NB SOIC-16, RoHS

# Si860xI2C-EVB UG

---

## 6. Ordering Guide

Table 2. Ordering Guide

Ordering Part Number	Description
Si860xI2C-KIT	Si860x I <sup>2</sup> C, SMBus Isolator Evaluation Kit





**Connecting Everyone  
and Everything,  
All the Time**



**Portfolio**

[skyworksinc.com](http://skyworksinc.com)

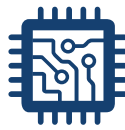

**Quality**

[skyworksinc.com/quality](http://skyworksinc.com/quality)



**Support & Resources**

[skyworksinc.com/support](http://skyworksinc.com/support)

**Copyright © 2022 Skyworks Solutions, Inc. All Rights Reserved.**

Information in this document is provided in connection with Skyworks Solutions, Inc. ("Skyworks") products or services. These materials, including the information contained herein, are provided by Skyworks as a service to its customers and may be used for informational purposes only by the customer. Skyworks assumes no responsibility for errors or omissions in these materials or the information contained herein. Skyworks may change its documentation, products, services, specifications or product descriptions at any time, without notice. Skyworks makes no commitment to update the materials or information and shall have no responsibility whatsoever for conflicts, incompatibilities, or other difficulties arising from any future changes.

No license, whether express, implied, by estoppel or otherwise, is granted to any intellectual property rights by this document. Skyworks assumes no liability for any materials, products or information provided hereunder, including the sale, distribution, reproduction or use of Skyworks products, information or materials, except as may be provided in Skyworks' Terms and Conditions of Sale.

THE MATERIALS, PRODUCTS AND INFORMATION ARE PROVIDED "AS IS" WITHOUT WARRANTY OF ANY KIND, WHETHER EXPRESS, IMPLIED, STATUTORY, OR OTHERWISE, INCLUDING FITNESS FOR A PARTICULAR PURPOSE OR USE, MERCHANTABILITY, PERFORMANCE, QUALITY OR NON-INFRINGEMENT OF ANY INTELLECTUAL PROPERTY RIGHT; ALL SUCH WARRANTIES ARE HEREBY EXPRESSLY DISCLAIMED. SKYWOKS DOES NOT WARRANT THE ACCURACY OR COMPLETENESS OF THE INFORMATION, TEXT, GRAPHICS OR OTHER ITEMS CONTAINED WITHIN THESE MATERIALS. SKYWOKS SHALL NOT BE LIABLE FOR ANY DAMAGES, INCLUDING BUT NOT LIMITED TO ANY SPECIAL, INDIRECT, INCIDENTAL, STATUTORY, OR CONSEQUENTIAL DAMAGES, INCLUDING WITHOUT LIMITATION, LOST REVENUES OR LOST PROFITS THAT MAY RESULT FROM THE USE OF THE MATERIALS OR INFORMATION, WHETHER OR NOT THE RECIPIENT OF MATERIALS HAS BEEN ADVISED OF THE POSSIBILITY OF SUCH DAMAGE.

Skyworks products are not intended for use in medical, lifesaving or life-sustaining applications, or other equipment in which the failure of the Skyworks products could lead to personal injury, death, physical or environmental damage. Skyworks customers using or selling Skyworks products for use in such applications do so at their own risk and agree to fully indemnify Skyworks for any damages resulting from such improper use or sale.

Customers are responsible for their products and applications using Skyworks products, which may deviate from published specifications as a result of design defects, errors, or operation of products outside of published parameters or design specifications. Customers should include design and operating safeguards to minimize these and other risks. Skyworks assumes no liability for applications assistance, customer product design, or damage to any equipment resulting from the use of Skyworks products outside of Skyworks' published specifications or parameters.

Skyworks, the Skyworks symbol, Sky5®, SkyOne®, SkyBlue™, Skyworks Green™, ClockBuilder®, DSPLL®, ISOmodem®, ProSLIC®, and SiPHY® are trademarks or registered trademarks of Skyworks Solutions, Inc. or its subsidiaries in the United States and other countries. Third-party brands and names are for identification purposes only and are the property of their respective owners. Additional information, including relevant terms and conditions, posted at [www.skyworksinc.com](http://www.skyworksinc.com), are incorporated by reference.

Skyworks Solutions, Inc. | Nasdaq: SWKS | [sales@skyworksinc.com](mailto:sales@skyworksinc.com) | [www.skyworksinc.com](http://www.skyworksinc.com)

USA: 781-376-3000 | Asia: 886-2-2735 0399 | Europe: 33 (0)1 43548540