

NOTES:

1. MATERIALS AND FINISHES:
 BODY-REAR, HOUSING,
 LOCK WASHER & HEX NUT - BRASS, TIN-NICKEL ALLOY PLATING
 CONTACT - BeCu, GOLD PLATING
 INSULATOR - PTFE, NATURAL
 GASKET & O-RING - SILICONE RUBBER, RED

2. ELECTRICAL:
 A. IMPEDANCE: 50 OHM
 B. DIELECTRIC WITHSTANDING VOLTAGE: 1000 VRMS, MIN.

3. MECHANICAL:
 A. DURABILITY: 500 CYCLES MIN.
 B. TEMPERATURE RANGE: -65°C TO 165°C
 C. SEALING REQUIREMENT: IP68 MUST WITHSTAND THE WATER PRESSURE AT THE DEPTH OF 1 METER FOR ONE HOUR AT 15 PSI WITHOUT ANY SIGNS OF LEAKAGE.
 D. SALT SPRAY PER MIL-STD-202, METHOD 101, WITH FOLLOWING PARAMETERS:
 1) TEST CONDITION B
 2) 5% SALT SOLUTION
 3) CYCLE REPEATED TO 720 HOURS

4. PACKAGING:
 A. QUANTITY: SINGLE PACK
 B. MARKING: PACKAGING TO BE MARKED
 "AMPHENOL RF, 242125-10-EE AND DATE CODE"

REVISIONS				
REV	DESCRIPTION	DATE	ECN	BY
A	RELEASE TO MFG.	25-AUG-22	16368	SG

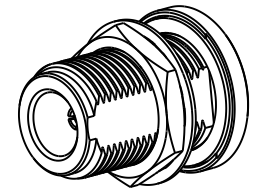

SCALE 1.000

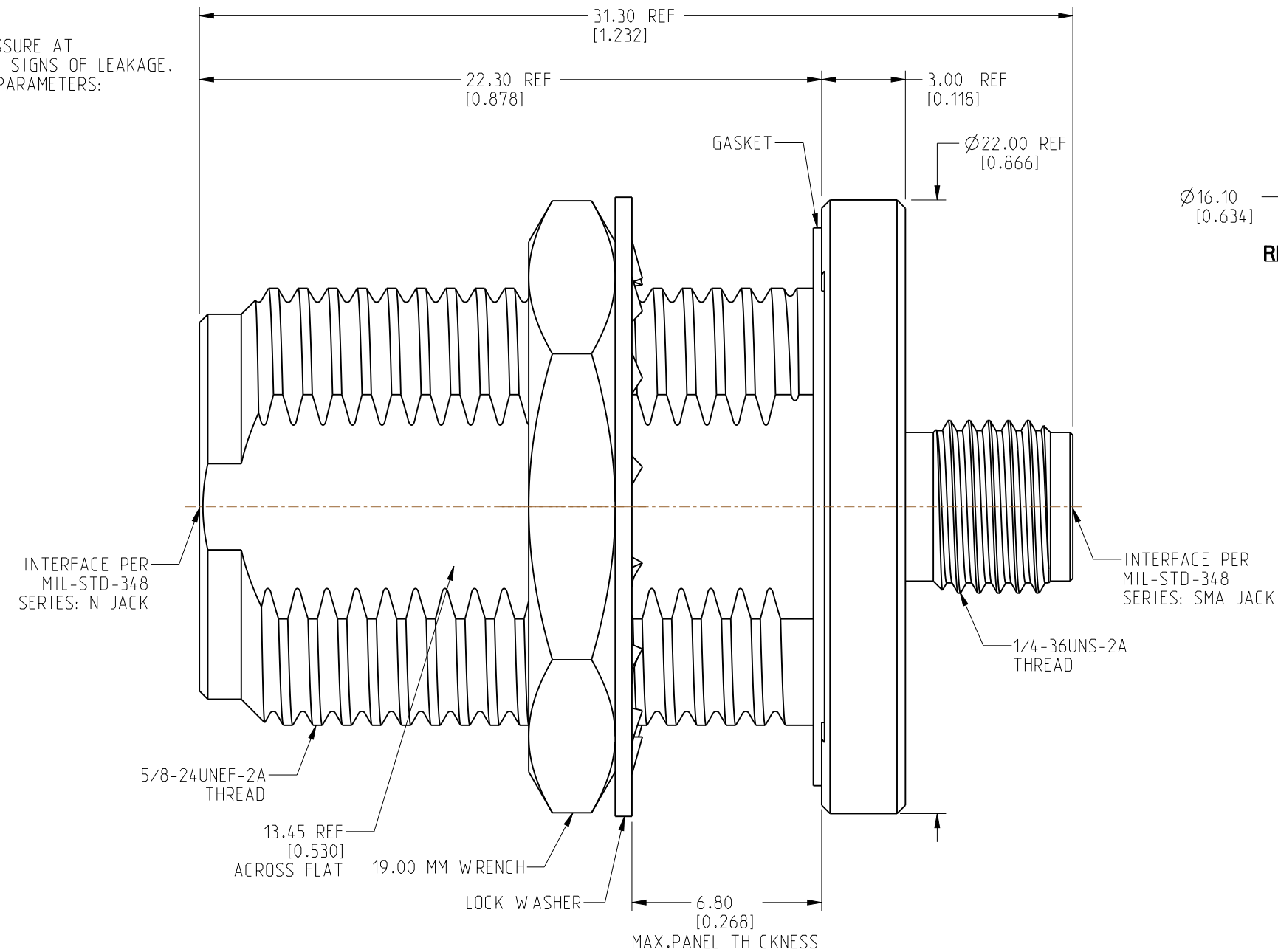
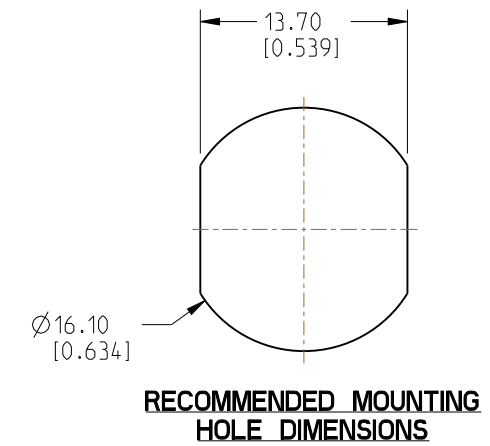

CUSTOMER OUTLINE DRAWING

ALL OTHER SHEETS ARE FOR INTERNAL USE ONLY

NOTICE: These drawings, specifications, or other data (1) are, and remain the property of Amphenol corp. (2) must be returned upon request; and (3) are confidential and not to be disclosed to any person other than those to whom they are given by Amphenol Corp. The furnishing of these drawings, specifications, or other data by Amphenol Corp., or to any other person to anyone for any purpose is not to be regarded by implication or otherwise in any manner licensing, granting rights to permitting such holder or any other person to manufacture, use or sell any product, process or design, patented or otherwise, that may in any way be related to or disclosed by said drawings, specifications, or other data.

UNLESS OTHERWISE SPECIFIED DIMENSIONS ARE METRIC (INCHES) AND TOLERANCES ARE:
 <0.5mm = ±0.05mm [-0.020 = ±0.002]
 0.5 - 6mm = ±0.1mm [+0.020 - 0.236 = ±0.004]
 >6.00 - 30mm = ±0.2mm [+0.236 - 1.181 = ±0.008]
 >30.00 - 120mm = ±0.3mm [+1.181 - 4.725 = ±0.012]
 ANGLES = ±1°

MATERIAL: SEE NOTES
 ENGR.1: SIVA
 ENGR.2:
 DATE: 28-JUN-22

TITLE: N STR JACK TO SMA BHD JACK ADAPTER IP 68 EXTREME EXPOSURE
 SHEET NO. 2 OF 2
 SCALE: 5.0:1.0

Amphenol RF		SIZE: B	DRAWING NO. 242125-10-EE	REV: A
			ITEM NO. 242125-10-EE	
			PART NO. 242125-10-EE	

THIRD ANGLE PROJ.

REFERENCE: 242125-10
 EAR#: 11376