



**ANATECH ELECTRONICS INC**  
RF & Microwave Filters & Products

## 30 MHz LC Band Pass Filter

Part Number: AE30B5737



### Electrical Specifications

**Center Frequency:** 30 MHz  
**3.0dB Passband:** 29-31 MHz  
**Insertion Loss:** 5.0dB Max.  
**Return Loss:** 14dB Min.  
**Rejection:**  $\geq 60$  dB @ 22 MHz  
**Rejection2:**  $\geq 60$  dB @ 38 MHz

### Mechanical

**Mounting Method:** Threaded Mounting Holes  
**Connector Type:** SMA (F)  
**Dimensions:** 1.0" X 0.5" x 0.4" .

### Environmental

**Operating Temperature:** -25°C to +70°C  
**Storage Temperature:** -40°C to +90°C  
**Shock:** 10 G. 11ms  
**Vibration:** 10 G. 5 to 200Hz

### Outline Drawing:

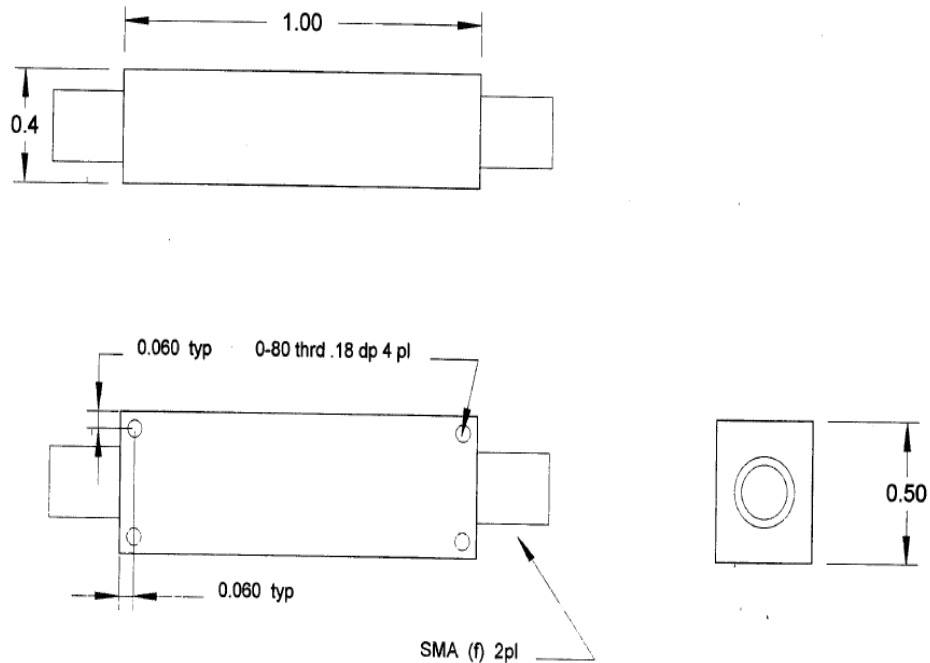



**Response Plot:**

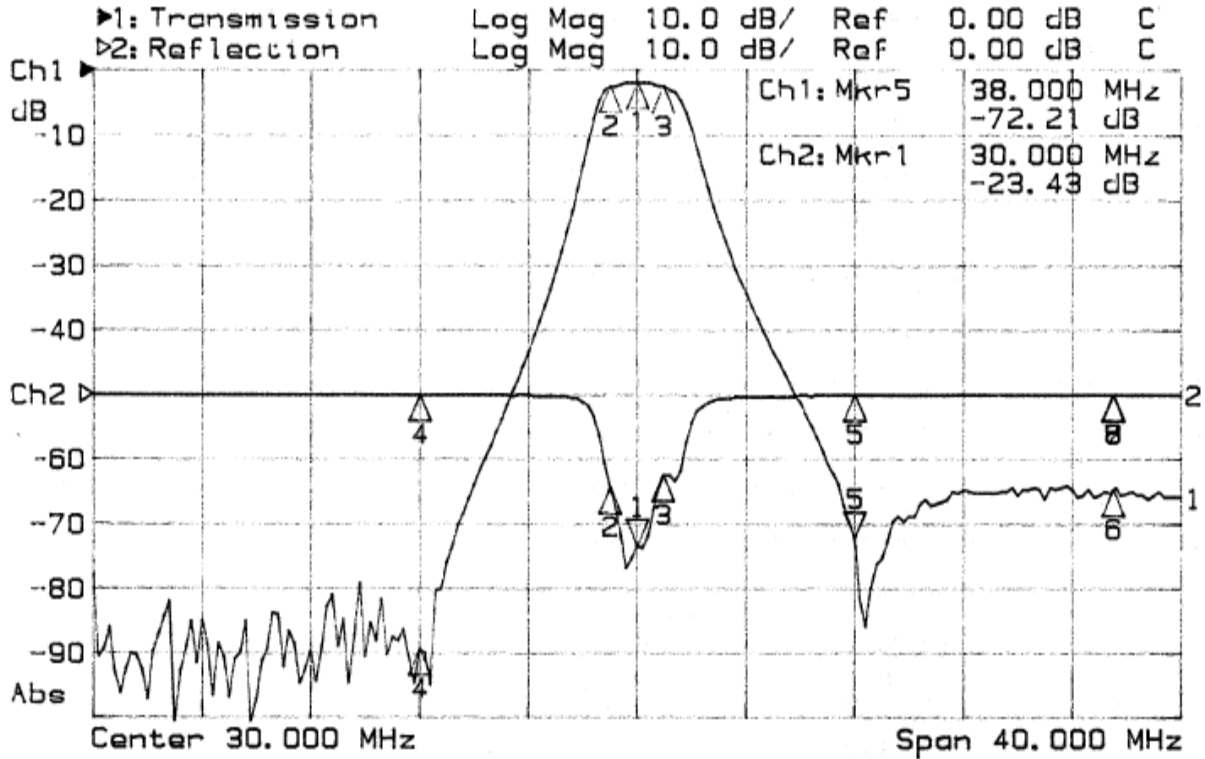

1: Mkr (MHz)	dB	2: Mkr (MHz)	dB		
1:	30.00	-1.95	1>	30.00	-23.43
2:	29.00	-2.61	2:	29.00	-14.34
3:	31.00	-2.65	3:	31.00	-12.58
4:	22.00	-89.49	4:	22.00	-0.05
5>	38.00	-72.21	5:	38.00	-0.10
6:	47.50	-64.83	6:	47.50	-0.05
			7:	47.50	-0.05
			8:	47.50	-0.05