

SE-EPI-06 MANUAL ENERGIZED PHASE INDICATOR

March 9, 2012

REVISION 3

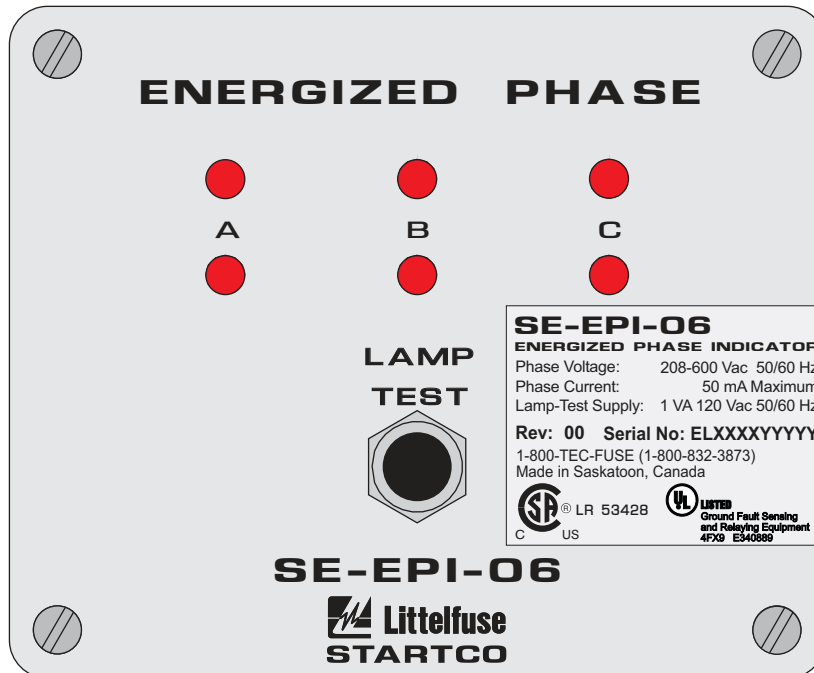

Copyright © 2012 by Littelfuse Startco

All rights reserved.

TABLE OF CONTENTS

	PAGE
Table of Contents	i
List of Figures.....	i
1. Features	1
2. Description	1
3. Installation	1
4. Technical Specifications	4

LIST OF FIGURES

FIGURE	PAGE
1. SE-EPI-06 Outline and Mounting Details	1
2. Connection Diagram for an Ungrounded 240- to 600-V System.....	2
3. Connection Diagram for Ungrounded Systems above 600 V	2
4. Connection Diagram for a Resistance-Grounded System up to 600-V	3
5. Connection Diagram for Resistance-Grounded Systems above 600 V	3

DISCLAIMER

Specifications are subject to change without notice. Littelfuse Startco is not liable for contingent or consequential damages, or for expenses sustained as a result of incorrect application, incorrect adjustment, or a malfunction.

1. FEATURES

- Red LED's indicate presence of voltage to ground for each phase of a power system.
 - Redundant LED's are used for reliability.
- Pressing LAMP TEST causes all LED's to light.

NOTE: The LAMP TEST feature requires an isolated 120 Vac supply.

- Direct connection for voltages up to 600 Vac line to line.
 - Potential transformers (PT's) are required for voltages greater than 600 Vac.

2. DESCRIPTION

The SE-EPI-06 is a self-powered voltage indication system. Presence of phase-to-ground voltage is indicated by redundant LED's (two per phase). The respective LED's are on when voltage is present.

3. INSTALLATION

Outline and panel-mounting details are shown in Fig. 1. For 208- to 600-Vac systems, connect the SE-EPI-06 directly to the three-phase bus. For 208- or 240-volt installations, use terminals AL, BL, and CL. For systems above 240 V and up to 600 V, use terminals AH, BH, and CH. See Figs. 2 and 4.

For systems above 600 V, install PT's as shown in Figs. 3 and 5.

Connect terminal G and chassis-bonding terminal (⊕) to ground.

For LAMP TEST connect 120 Vac supply to L and G. Connection and use of LAMP TEST circuit is optional.

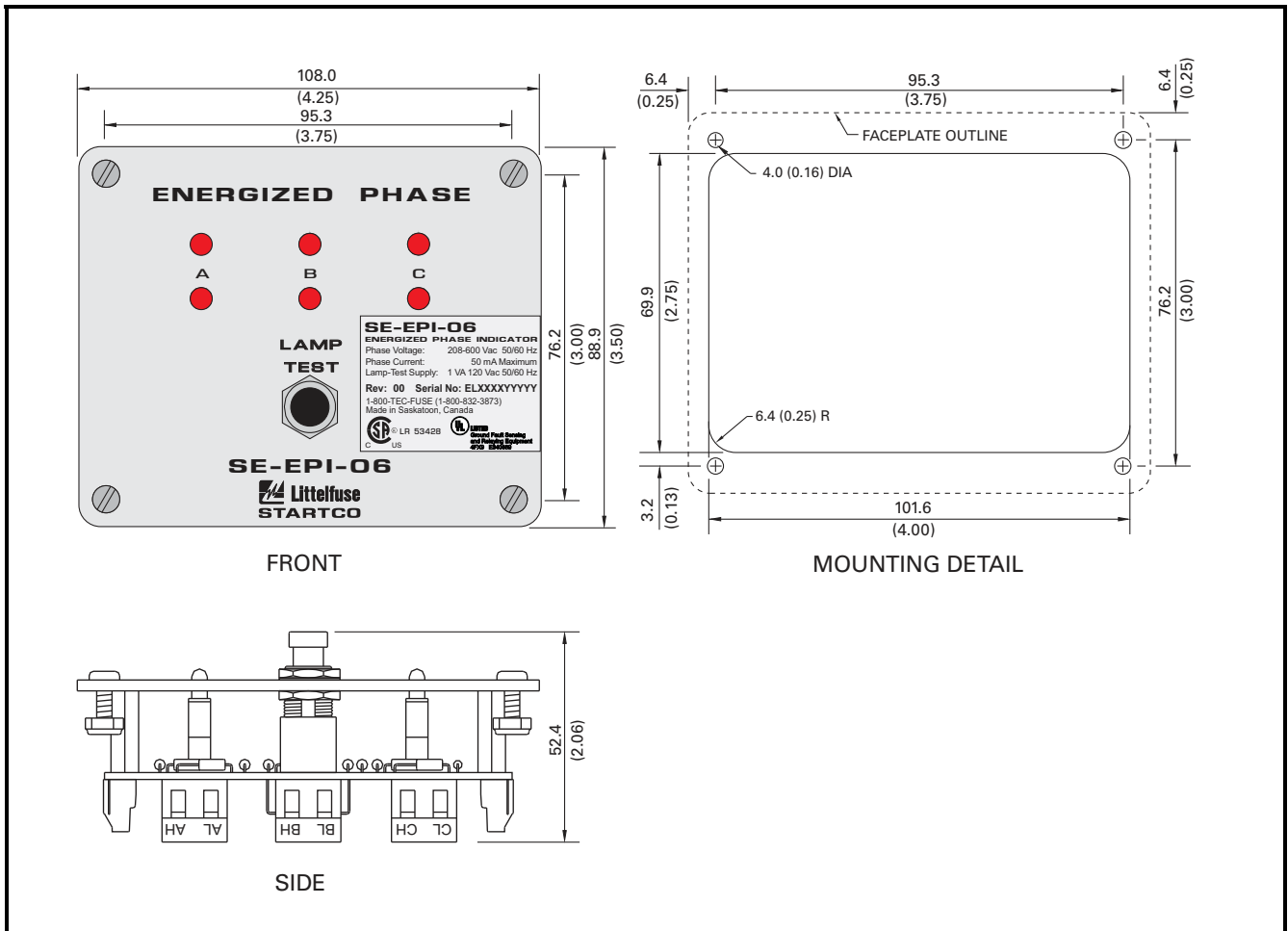

FIGURE 1. SE-EPI-06 Outline and Mounting Details.

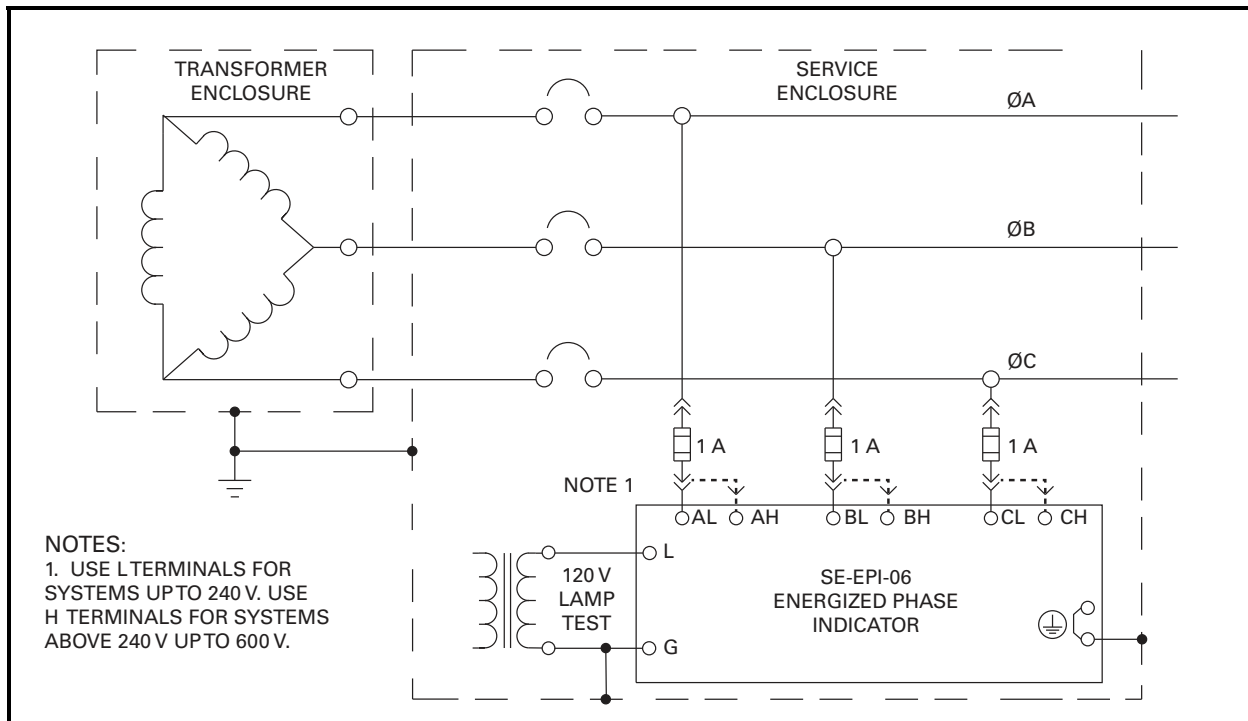

FIGURE 2. Connection Diagram for an Ungrounded 240- to 600-V System.

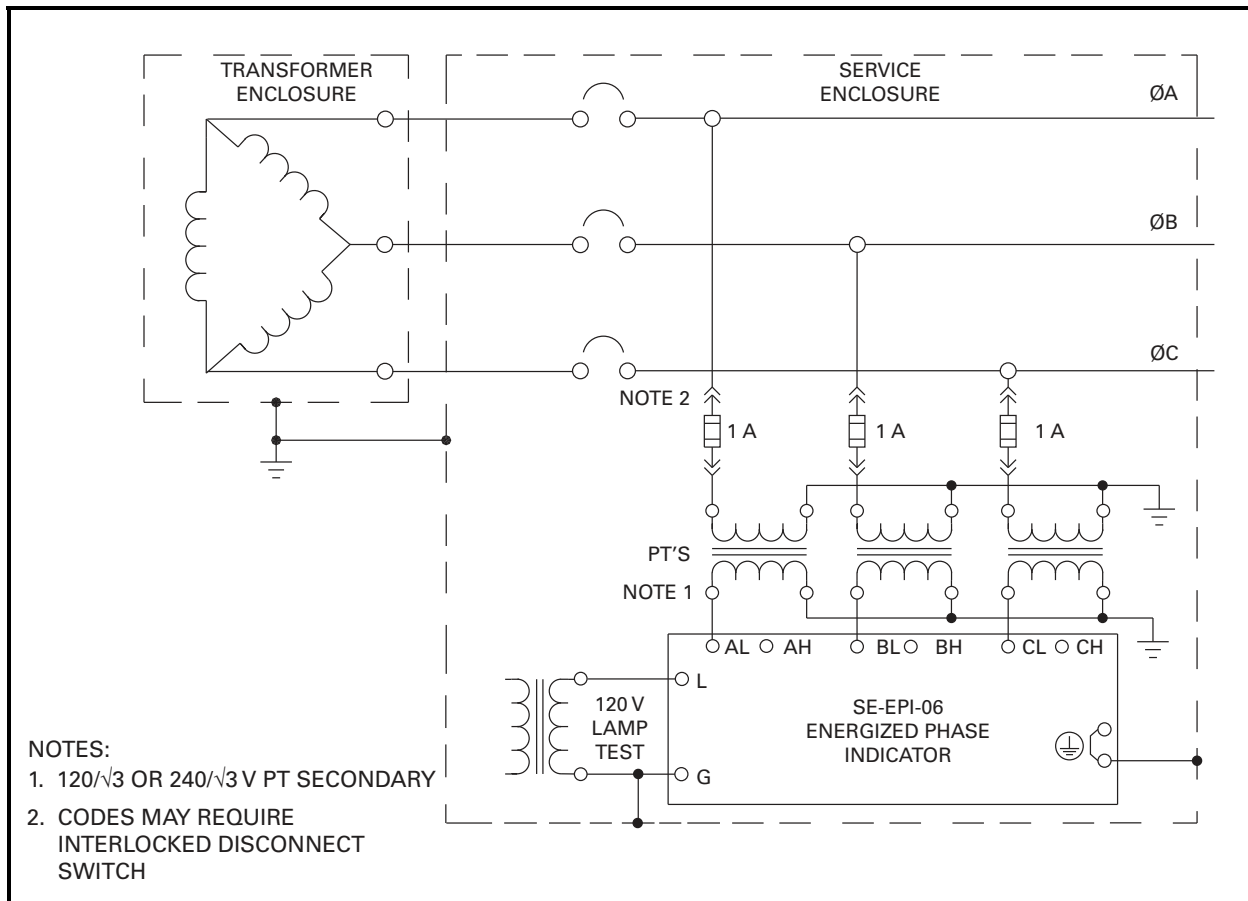

FIGURE 3. Connection Diagram for Ungrounded Systems above 600 V.

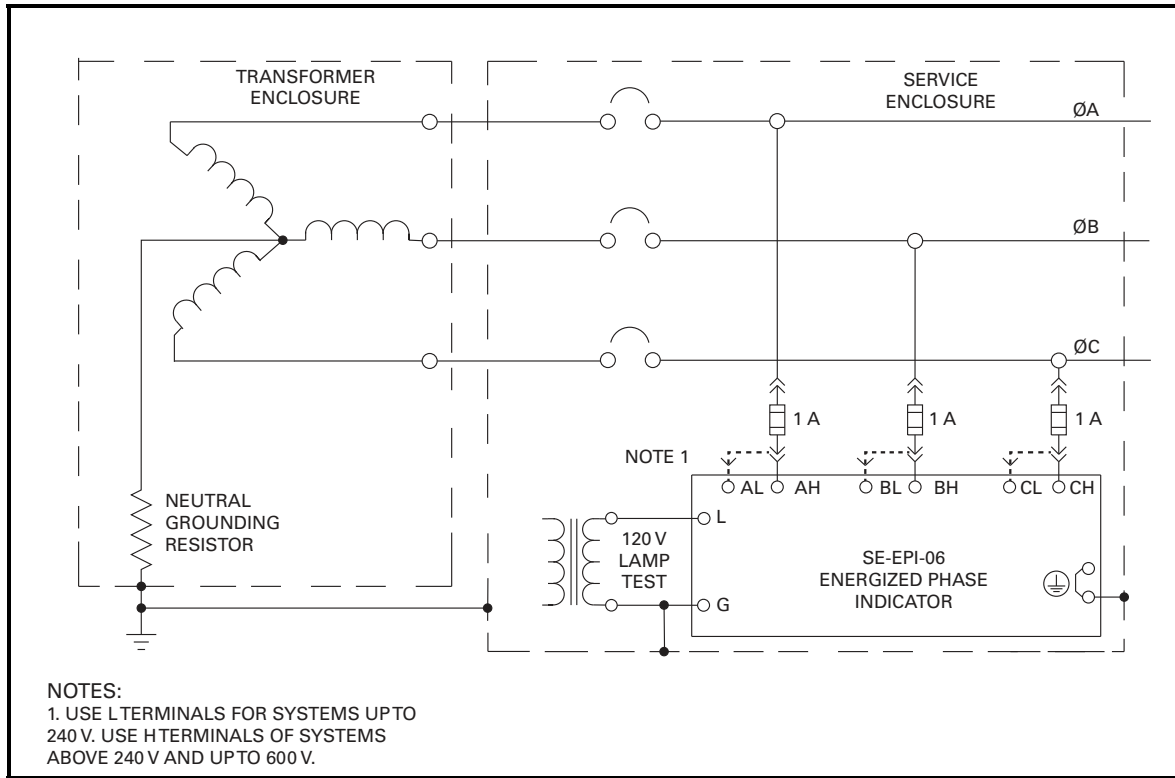

FIGURE 4. Connection Diagram for a Resistance-Grounded System up to 600 V.

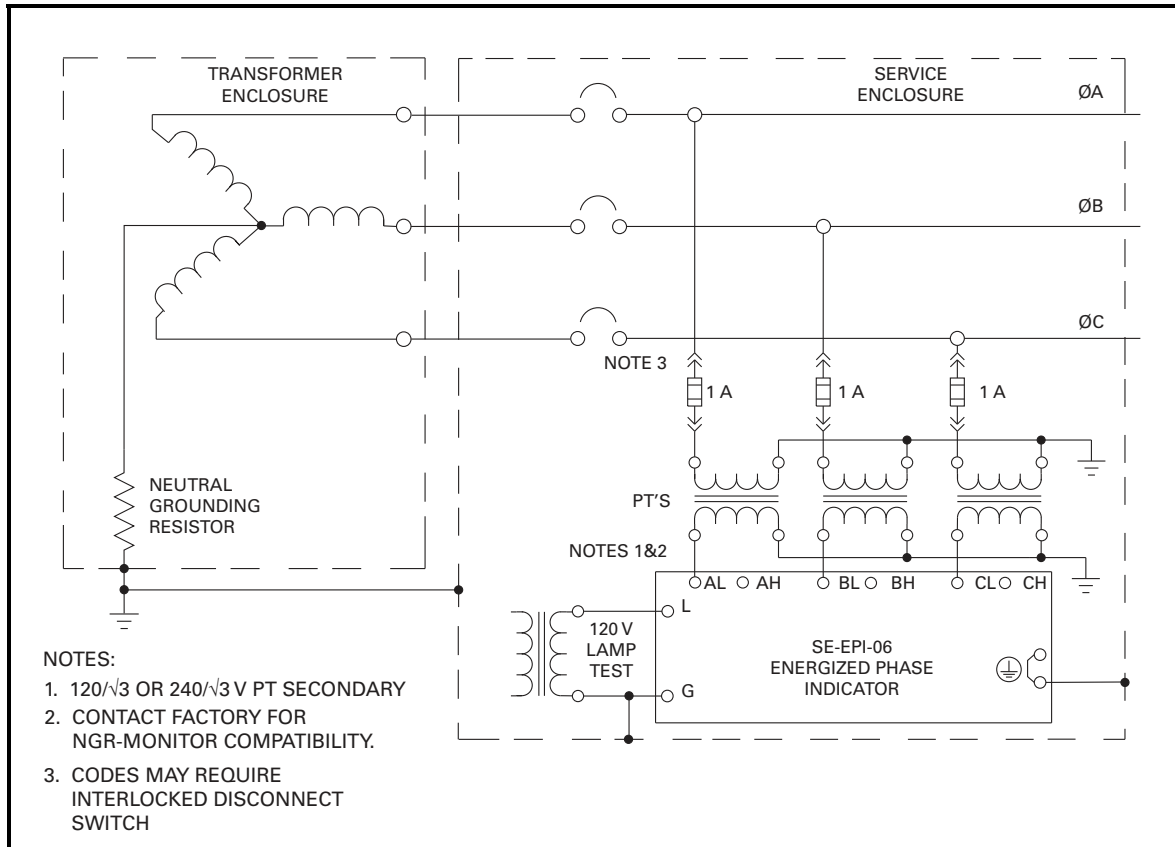

FIGURE 5. Connection Diagram for Resistance-Grounded Systems above 600 V.

4. TECHNICAL SPECIFICATIONS

Phase Voltage

Input L, maximums 240 Vac to ground,
3.5 mA
Input H, maximums..... 600 Vac to ground,
4.5 mA

Lamp Test Input Isolated 120 Vac,
1 VA maximum

Dielectric Strength..... 2,200 Vac, 1 minute

Shipping Weight..... 0.3 kg (0.8 lb.)

Dimensions:

Height..... 108 mm (4.3")
Weight..... 88.9 mm (3.5")
Depth..... 54 mm (2.1")

Environment:

Operating Temperature..... -40 to 60°C
Storage Temperature -55 to 80°C
Humidity 85% Non-Condensing

PWB Conformal Coating MIL-1-46058 qualified
UL QMJU2 recognized

Certification..... CSA, Canada and USA



UL Listed

