

LT3960 I²C to CAN-Physical Transceiver

DESCRIPTION

Evaluation circuit EVAL-LT3960-AZ features the **LT[®]3960**, an I²C to CAN-Physical transceiver in a 10-lead plastic MSOP package. EVAL-LT3960-AZ consists of two ICs configured in the master and slave mode using selectable jumpers, JP1 and JP3. The board is designed to be easily snapped apart at the center, separating two circuitries.

The LT3960 I²C to CAN-Physical transceiver is used to send and receive I²C data through harsh or noisy environments at up to 400kb/s using the CAN-Physical layer for differential signaling over twisted pair connections. The SDA and SCL data lines are converted to differential signals and are shared between devices connected to the bus. This allows for the physical separation of the I²C source and I²C receiver.

The first LT3960 is connected to the I²C master (I²C-compatible microcontroller). The second LT3960 should be connected to the first LT3960 by two twisted pairs. It regenerates the I²C bus locally for one or more I²C slave devices. The LT3960 devices transmit the clock signal in only one direction, from master to slave. Bidirectional communication of the data signal is always permitted.

The LT3960 data sheet gives a complete description of the parts, their operation, and application information. The data sheet must be read in conjunction with this user guide for the evaluation circuit EVAL-LT3960-AZ. The LT3960EMSE is assembled in a 10-lead MSOP package.

[Design files for this circuit board are available.](#)

All registered trademarks and trademarks are the property of their respective owners.

PERFORMANCE SUMMARY Specifications are at T_A = 25°C

SYMBOL	PARAMETER	CONDITION	MIN	TYP	MAX	UNIT
V _{IN}	Input Voltage	V _{IN} Tied to V _{CC} , 3.3V Range (Jumper JP2, JP4: V _{IN} = V _{CC})	3	3.3	3.6	V
		V _{IN} Tied to V _{CC} , 5V Range (Jumper JP2, JP4: V _{IN} = V _{CC})	4.5	5	5.5	V
		V _{CC} Regulated Internally from V _{IN} (Jumper JP2, JP4: V _{IN} ≠ V _{CC})	4		60	V
V _{MSTR} , V _{SLV} , V _{SHDN}	EN/MODE Voltage	Master Mode (Jumper JP1, JP3: MASTER)	2		5	V
		Slave Mode (Jumper JP1, JP3: SLAVE)	0.7		2	V
		Low Power Shutdown Mode (Jumper JP1, JP3: OFF)	0		0.7	V
f _{CLK}	Clock Frequency				400	kHz
V _{CM}	Bus Common Mode Voltage	V _{CC} = 3.3V			±25	V
		V _{CC} = 5V			±36	V

QUICK START PROCEDURE

EVAL-LT3960-AZ can be powered by a voltage source between 4V and 60V due to the integrated LDO in the LT3960. The LDO regulates the input from the V_{IN} pin between 4V and 60V to 3.3V on the V_{CC} pin from which the transceivers and bus lines are powered. Alternatively, the EVAL-LT3960-AZ can be powered from a supply voltage of 3.3V or 5V on V_{IN} , bypassing the LDO by shorting V_{CC} to V_{IN} using jumpers JP2 and JP4.

One procedure for using the EVAL-LT3960-AZ is described as follows:

1. Launch Arduino IDE.
2. Connect two Linduinos to the computer via USB.
3. Download the Linduino code from the EVAL-LT3960-AZ webpage.
4. Upload the code to the master and slave Linduinos accordingly.
5. Break the EVAL-LT3960-AZ into two separate boards by applying force to the horizontal scoring line.
6. Use 2 twisted pairs of small wires to connect CANSCLx1 and CANSCLx2; CANSDAx1 and CANS-DAx2.
7. Connect GND1 and GND2 pins on two boards using a small wire (optional).
8. Connect SLC, SDA, GND pins from the master (slave) Linduino to SLC1, SDA1, GND1 (SLC2, SDA2, GND2) of the EVAL-LT3960-AZ, respectively.
9. With input power off, connect the first (second) input power supply to VIN1 and GND1 (VIN2 and GND2) of the EVAL-LT3960-AZ.
10. Turn on input power supplies.
11. Open the serial monitor associated with the slave Linduino and check the received message.

QUICK START PROCEDURE

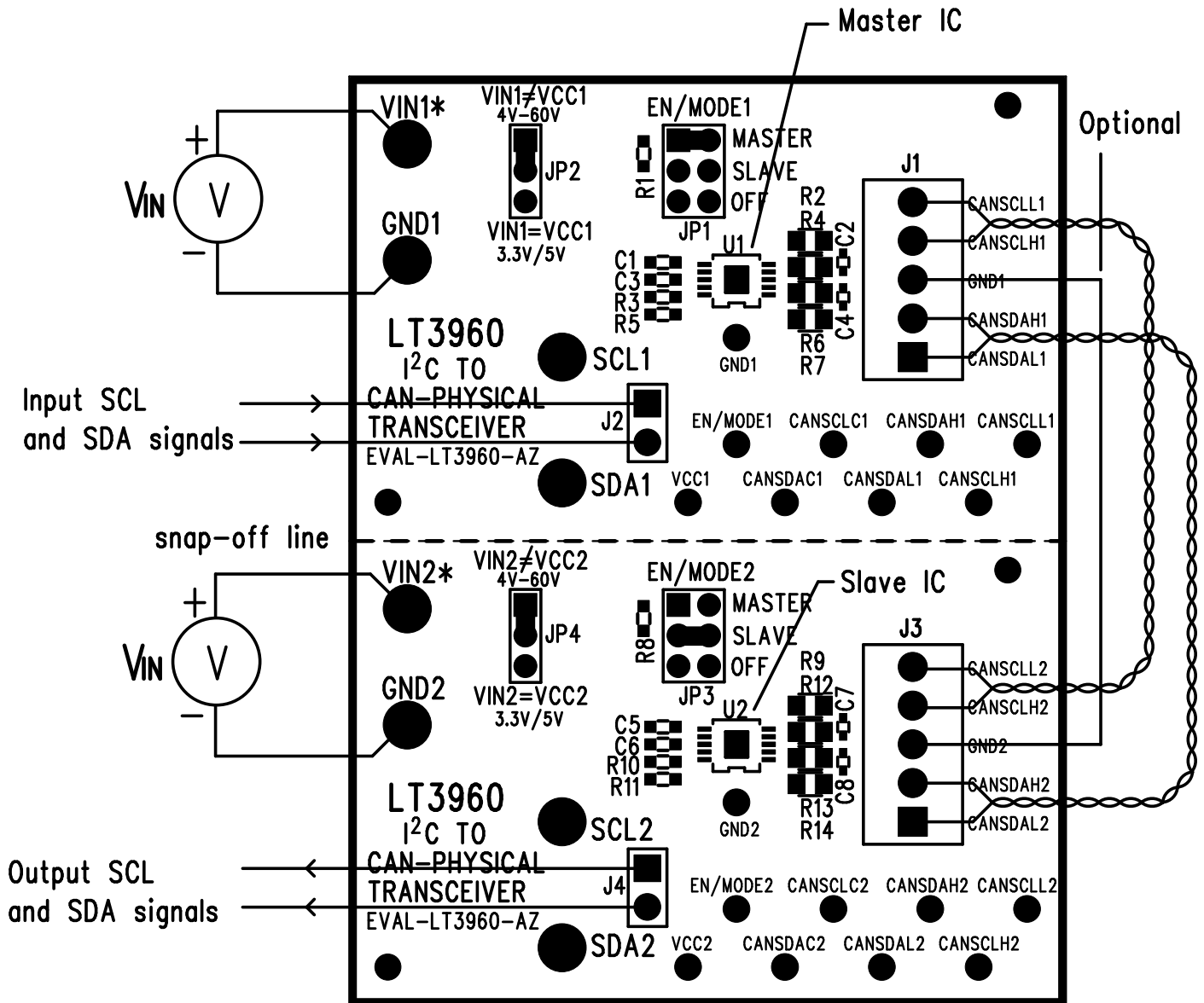

Figure 1. Quick Start Procedure Setup Drawing for EVAL-LT3960-AZ

TEST RESULTS

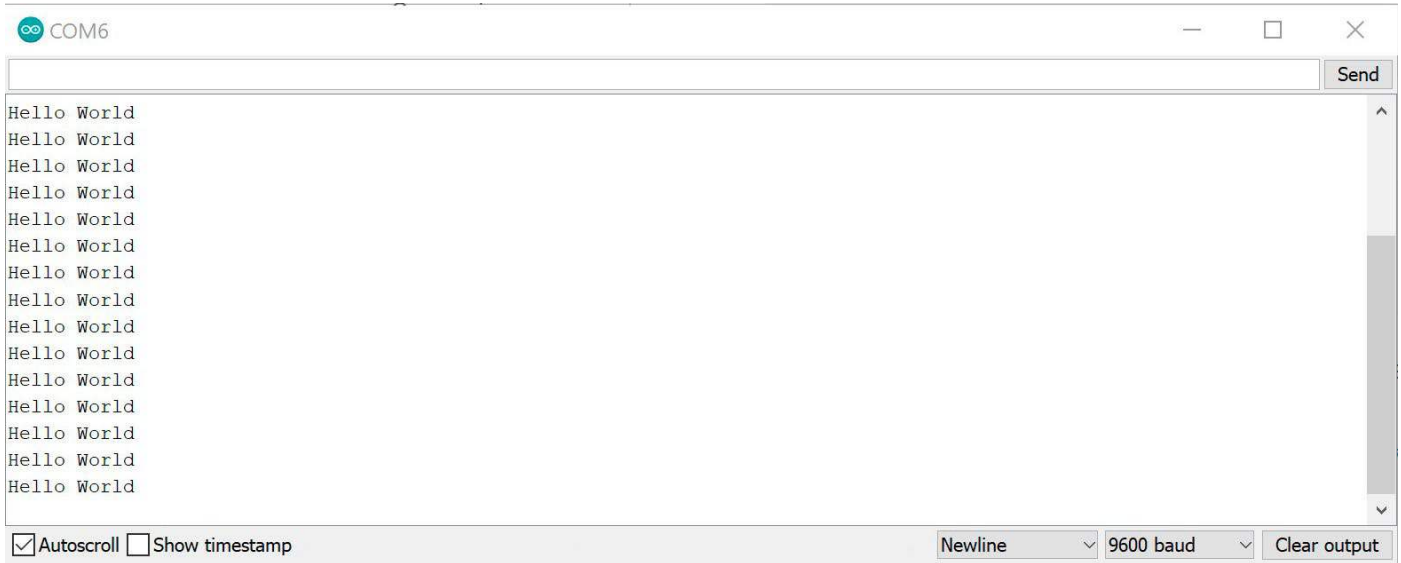
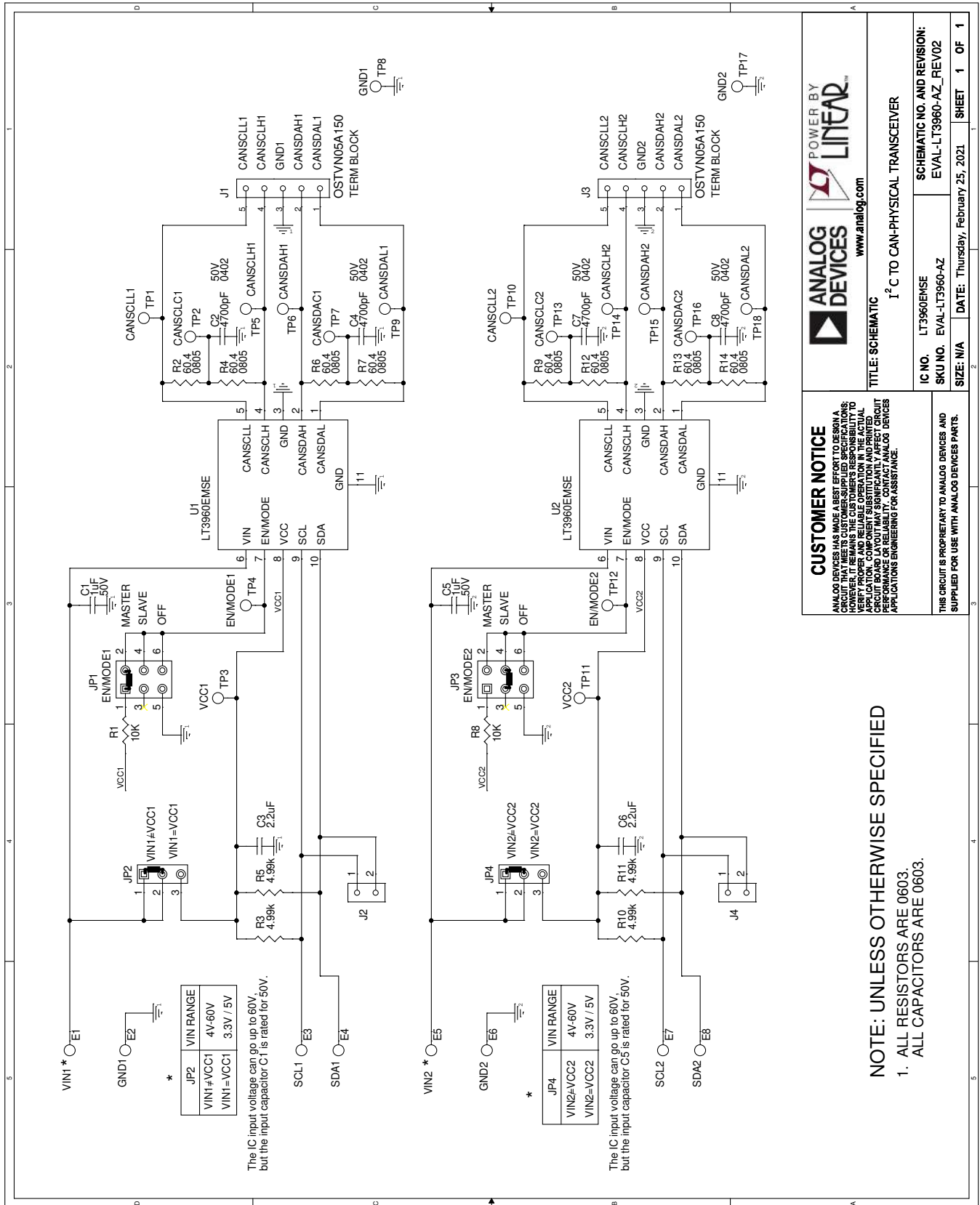

Figure 2. Linduino COM Terminal Window of the Slave Device

PARTS LIST

ITEM	QTY	REFERENCE	PART DESCRIPTION	MANUFACTURER/PART NUMBER
Required Circuit Components				
1	2	C1, C5	CAP, 1µF, X7R, 50V, 10%, 0603	YAGEO, CC0603KRX7R9BB105
2	4	C2, C4, C7, C8	CAP, 4700pF, X7R, 50V, 10%, 0402	MURATA, GRM155R71H472KA01D
3	2	C3, C6	CAP, 2.2µF, X7S, 10V, 10%, 0603, AEC-Q200	TDK, CGA3E3X7S1A225K080AB
4	2	R1, R8	RES., 10k, 1%, 1/10W, 0603, AEC-Q200	VISHAY, CRCW060310K0FKEA
5	8	R2, R4, R6, R7, R9, R12, R13, R14	RES., 60.4Ω, 1%, 1/8W, 0805, AEC-Q200	PANASONIC, ERJ6ENF60R4V
6	4	R3, R5, R10, R11	RES., 4.99k, 1%, 1/10W, 0603, AEC-Q200	PANASONIC, ERJ3EKF4991V
7	2	U1, U2	IC, 12C TO DUAL CAN TRANSCEIVER, MSOP-10	ANALOG DEVICES, LT3960EMSE#PBF
Hardware: For Demo Board Only				
1	8	E1-E8	TEST POINT, TURRET, 0.064" MTG. HOLE, PCB 0.062" THK	MILL-MAX, 2308-2-00-80-00-00-07-0
2	2	J1, J3	CONN., TERM BLOCK, 5 POS, 2.54mm, ST, THT, SIDE ENTRY, GREEN	ON-SHORE TECHNOLOGY, OSTVN05A150
3	2	J2, J4	CONN., HDR, MALE, 1x2, 2.54mm, VERT, ST, THT	WURTH ELEKTRONIK, 61300211121
4	2	JP1, JP3	CONN., HDR, MALE, 2x3, 2mm, VERT, ST, THT	WURTH ELEKTRONIK, 62000621121
5	2	JP2, JP4	CONN., HDR, MALE, 1x3, 2mm, VERT, ST, THT	WURTH ELEKTRONIK, 62000311121
6	18	TP1-TP18	TEST POINT, 1POS, 0.040" MTG. HOLE, 2.54mm DIA x 4.57mm L, THT, BLACK	KEYSTONE, 5001
7	4	XJP1, XJP2, XJP3, XJP4	CONN., SHUNT, FEMALE, 2 POS, 2mm	WURTH ELEKTRONIK, 60800213421

SCHEMATIC DIAGRAM





ESD Caution

ESD (electrostatic discharge) sensitive device. Charged devices and circuit boards can discharge without detection. Although this product features patented or proprietary protection circuitry, damage may occur on devices subjected to high energy ESD. Therefore, proper ESD precautions should be taken to avoid performance degradation or loss of functionality.

Legal Terms and Conditions

By using the evaluation board discussed herein (together with any tools, components documentation or support materials, the "Evaluation Board"), you are agreeing to be bound by the terms and conditions set forth below ("Agreement") unless you have purchased the Evaluation Board, in which case the Analog Devices Standard Terms and Conditions of Sale shall govern. Do not use the Evaluation Board until you have read and agreed to the Agreement. Your use of the Evaluation Board shall signify your acceptance of the Agreement. This Agreement is made by and between you ("Customer") and Analog Devices, Inc. ("ADI"), with its principal place of business at One Technology Way, Norwood, MA 02062, USA. Subject to the terms and conditions of the Agreement, ADI hereby grants to Customer a free, limited, personal, temporary, non-exclusive, non-sublicensable, non-transferable license to use the Evaluation Board FOR EVALUATION PURPOSES ONLY. Customer understands and agrees that the Evaluation Board is provided for the sole and exclusive purpose referenced above, and agrees not to use the Evaluation Board for any other purpose. Furthermore, the license granted is expressly made subject to the following additional limitations: Customer shall not (i) rent, lease, display, sell, transfer, assign, sublicense, or distribute the Evaluation Board; and (ii) permit any Third Party to access the Evaluation Board. As used herein, the term "Third Party" includes any entity other than ADI, Customer, their employees, affiliates and in-house consultants. The Evaluation Board is NOT sold to Customer; all rights not expressly granted herein, including ownership of the Evaluation Board, are reserved by ADI. CONFIDENTIALITY. This Agreement and the Evaluation Board shall all be considered the confidential and proprietary information of ADI. Customer may not disclose or transfer any portion of the Evaluation Board to any other party for any reason. Upon discontinuation of use of the Evaluation Board or termination of this Agreement, Customer agrees to promptly return the Evaluation Board to ADI. ADDITIONAL RESTRICTIONS. Customer may not disassemble, decompile or reverse engineer chips on the Evaluation Board. Customer shall inform ADI of any occurred damages or any modifications or alterations it makes to the Evaluation Board, including but not limited to soldering or any other activity that affects the material content of the Evaluation Board. Modifications to the Evaluation Board must comply with applicable law, including but not limited to the RoHS Directive. TERMINATION. ADI may terminate this Agreement at any time upon giving written notice to Customer. Customer agrees to return to ADI the Evaluation Board at that time. LIMITATION OF LIABILITY. THE EVALUATION BOARD PROVIDED HEREUNDER IS PROVIDED "AS IS" AND ADI MAKES NO WARRANTIES OR REPRESENTATIONS OF ANY KIND WITH RESPECT TO IT. ADI SPECIFICALLY DISCLAIMS ANY REPRESENTATIONS, ENDORSEMENTS, GUARANTEES, OR WARRANTIES, EXPRESS OR IMPLIED, RELATED TO THE EVALUATION BOARD INCLUDING, BUT NOT LIMITED TO, THE IMPLIED WARRANTY OF MERCHANTABILITY, TITLE, FITNESS FOR A PARTICULAR PURPOSE OR NON-INFRINGEMENT OF INTELLECTUAL PROPERTY RIGHTS. IN NO EVENT WILL ADI AND ITS LICENSORS BE LIABLE FOR ANY INCIDENTAL, SPECIAL, INDIRECT, OR CONSEQUENTIAL DAMAGES RESULTING FROM CUSTOMER'S POSSESSION OR USE OF THE EVALUATION BOARD, INCLUDING BUT NOT LIMITED TO LOST PROFITS, DELAY COSTS, LABOR COSTS OR LOSS OF GOODWILL. ADI'S TOTAL LIABILITY FROM ANY AND ALL CAUSES SHALL BE LIMITED TO THE AMOUNT OF ONE HUNDRED US DOLLARS (\$100.00). EXPORT. Customer agrees that it will not directly or indirectly export the Evaluation Board to another country, and that it will comply with all applicable United States federal laws and regulations relating to exports. GOVERNING LAW. This Agreement shall be governed by and construed in accordance with the substantive laws of the Commonwealth of Massachusetts (excluding conflict of law rules). Any legal action regarding this Agreement will be heard in the state or federal courts having jurisdiction in Suffolk County, Massachusetts, and Customer hereby submits to the personal jurisdiction and venue of such courts. The United Nations Convention on Contracts for the International Sale of Goods shall not apply to this Agreement and is expressly disclaimed.