

DATA SHEET

SKY13588-460LF: 0.1 to 6.0 GHz SP3T Switch

Applications

- WCDMA band and mode switching
- Antenna switch for multimode systems
- 802.11a/b/g/n WLANs
- Industrial IoT
- Lighting
- Smart energy
- Connected home

Features

- Broadband frequency range: 0.1 to 6.0 GHz
- Low insertion loss: 0.45 dB @ 2.5 GHz
- High isolation: 30 dB up to 2.5 GHz
- No external DC blocking capacitors required
- Positive low voltage control: $V_{CTL} = 1.65$ to 3.00 V, $V_{DD} = 2.5$ to 4.8 V
- Operating temperature range: -40 °C to $+105$ °C
- Small QFN (12-pin, $2 \times 2 \times 0.55$ mm) package (MSL1, 260 °C per JEDEC J-STD-020)



Skyworks Green™ products are compliant with all applicable legislation and are halogen-free. For additional information, refer to *Skyworks Definition of Green™*, document number SQ04-0074.

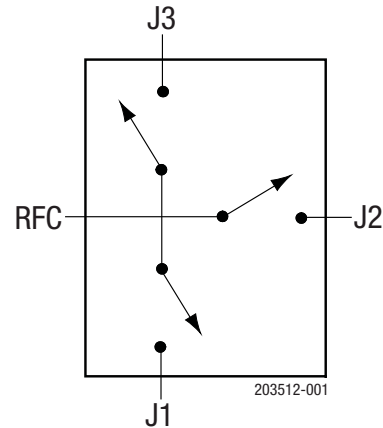

Figure 1. SKY13588-460LF Block Diagram

Description

The SKY13588-460LF is a CMOS silicon-on-insulator (SOI), single-pole, triple-throw (SP3T) switch. The high-linearity performance and low insertion loss makes the device an ideal choice for WCDMA handset and data card applications.

The SKY13588-460LF SP3T switch is provided in a compact Quad Flat No-Lead (QFN) $2 \times 2 \times 0.55$ mm package. A functional block diagram is shown in Figure 1. The pin configuration and package are shown in Figure 2. Signal pin assignments and functional pin descriptions are provided in Table 1.

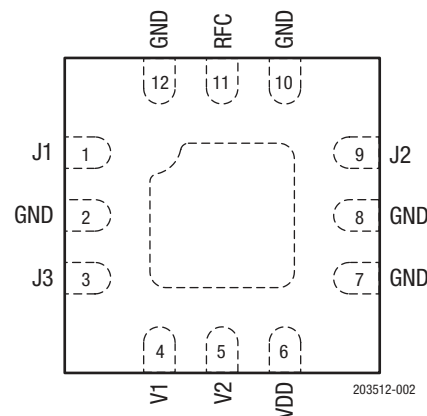

Figure 2. SKY13588-460LF Pinout (Top View)

Table 1. SKY13588-460LF Signal Descriptions¹

Pin	Name	Description	Pin	Name	Description
1	J1	RF port 1.	7	GND	Ground
2	GND	Ground	8	GND	Ground
3	J3	RF port 3.	9	J2	RF port 2
4	V1	DC control voltage 1 (see Table 4)	10	GND	Ground
5	V2	DC control voltage 2 (see Table 4)	11	RFC	RF common (antenna) port
6	VDD	DC power supply.	12	GND	Ground

¹ Exposed pad must be grounded.

Functional Description

The SKY13588-460LF includes an internal negative voltage generator and decoder that eliminate the need for external DC blocking capacitors on the RF ports. No external components are required for proper operation. DC decoupling capacitors can be added on the VDD and control lines if necessary.

Switching is controlled by two control voltage inputs (V1 and V2). Depending on the logic voltage level applied to the control pins, the RFC (RF common) pin is connected to one of three switched RF outputs (J1, J2, or J3) through a low insertion path, while the path between the RFC pin and the other RF pins is in a high isolation state.

Shutdown mode is enabled by connecting all control pins to logic low. This mode reduces the overall current consumption of the device to 5 μ A, typical. To prevent the switch from accidentally entering shutdown mode during switching, all states must be set to logic low for at least 20 μ s. When exiting shutdown mode, the switch has a 10.5 μ s startup time before switching occurs.

Electrical and Mechanical Specifications

The absolute maximum ratings of the SKY13588-460LF are provided in Table 2. Electrical specifications are provided in Table 3.

The state of the SKY13588-460LF is determined by the logic provided in Table 4.

Typical performance characteristics of the SKY13588-460LF are illustrated in Figures 3 through 6.

Table 2. SKY13588-460LF Absolute Maximum Ratings¹

Parameter	Symbol	Minimum	Maximum	Units
Supply voltage	V _{DD}	2.5	4.8	V
Control voltage ²	V _{CTL}	1.65	3.30	V
Input power	P _{IN}		+39	dBm
Storage temperature	T _{STG}	-40	+125	°C
Operating temperature	T _{OP}	-40	+105	°C

¹ Exposure to maximum rating conditions for extended periods may reduce device reliability. There is no damage to device with only one parameter set at the limit and all other parameters set at or below their nominal value. Exceeding any of the limits listed here may result in permanent damage to the device.

² Any bias voltage applied to the V1 or V2 pin may damage the device if there is no bias voltage also present on the VDD pin. Maximum control voltage cannot exceed V_{DD}.

ESD HANDLING: *Although this device is designed to be as robust as possible, electrostatic discharge (ESD) can damage this device. This device must be protected at all times from ESD when handling or transporting. Static charges may easily produce potentials of several kilovolts on the human body or equipment, which can discharge without detection. Industry-standard ESD handling precautions should be used at all times.*

Table 3. SKY13588-460LF Electrical Specifications¹**(V_{DD} = 2.3 V to 4.8 V, V₁ = V₂ = 0 to 1.8 V, T_{OP} = +25 °C, P_{IN} = 0 dBm, Characteristic Impedance [Z₀] = 50 Ω, Unless Otherwise Noted)**

Parameter	Symbol	Test Condition	Min	Typical	Max	Units
RF Specifications						
Insertion loss	IL	0.8 to 1.0 GHz		0.35	0.40	dB
		1.0 to 2.2 GHz		0.40	0.55	dB
		2.2 to 3.0 GHz		0.50	0.60	dB
		4.9 to 6.0 GHz		0.80	1.00	dB
Isolation	ISO	0.8 to 1.0 GHz	35	40		dB
		1.0 to 2.2 GHz	28	33		dB
		2.2 to 3.0 GHz	25	30		dB
		4.9 to 6.0 GHz	18	22		dB
Return loss	S ₁₁	0.8 to 6.0 GHz		17		dB
Third order input intercept point	IIP3	0.8 to 3.0 GHz, ΔF = 1 MHz, P _{IN} = +20 dBm/tone	+65	+70		dBm
Input 0.1 dB compression point	P _{0.1dB}	0.8 to 6.0 GHz, RFC to J1, J2, and J3		+39		dBm
2 nd harmonic	2f _o	0.8 to 3.0 GHz, P _{IN} = +20 dBm		+85		dBc
3 rd harmonic	3f _o	0.8 to 3.0 GHz, P _{IN} = +20 dBm		+85		dBc
Switching rise time		10/90% RF		250		ns
Switching fall time		90/10% RF		250		ns
Switching on time		50% V _{CTL} to 10/90% RF		1500		ns
Switching off time		50% V _{CTL} to 90/10% RF		1500		ns
Startup time		Shutdown state to any RF switch state		20		μs
DC Specifications						
Control voltage: High Low	V _{CTL_HIGH}		1.65	1.80	3.00 ²	V
	V _{CTL_LOW}		0		0.4	V
Supply voltage	V _{DD}		2.5		4.8	V
Supply current	I _{DD}	V _{DD} = 3.5 V		60		μA
Control current	I _{ctl}	V ₁ = V ₂ = 1.8 V		2		μA
Shutdown mode supply current	I _{off}	V _{DD} = 3.5 V, V ₁ = V ₂ = 0 V		5		μA

¹ Performance is guaranteed only under the conditions listed in this table.² Control voltage should not exceed supply voltage.**Table 4. SKY13588-460LF Truth Table¹**

V1 (Pin 4)	V2 (Pin 5)	State
0	0	Shutdown
1	0	RFC to J2
0	1	RFC to J1
1	1	RFC to J3

¹ "1" = 1.65 to 3.00 V

"0" = 0 to 0.4 V

Any state other than described in this table places the switch into an undefined state.

Typical Performance Characteristics

(V_{DD} = 2.3 V to 4.8 V, V_{I1} = V_{I2} = 0 to 1.8 V, T_{OP} = +25 °C, Pin = 0 dBm, Characteristic Impedance [Z₀] = 50 Ω, Unless Otherwise Noted)

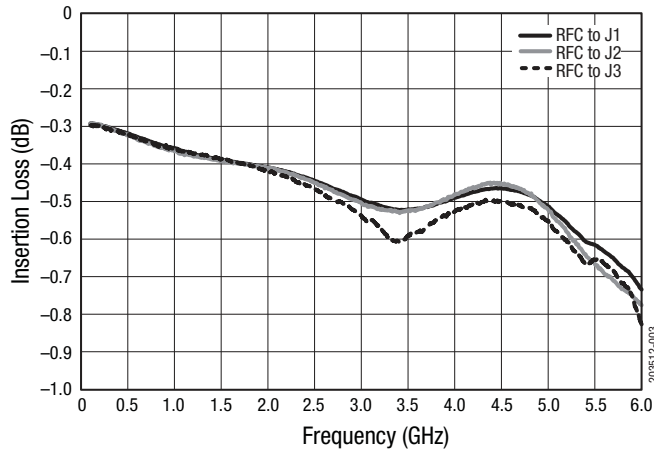

Figure 3. Typical Insertion Loss vs Frequency

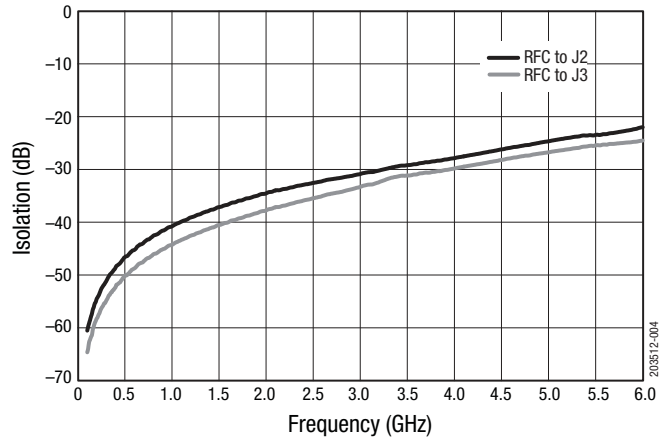

Figure 4. Typical Isolation vs Frequency (RFC to J1 Insertion Loss State)

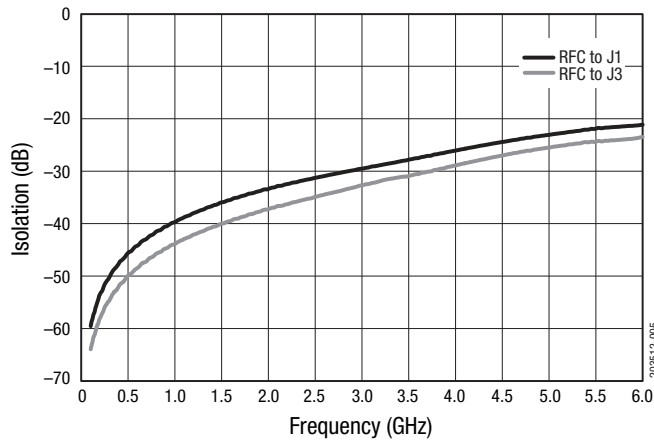

Figure 5. Typical Isolation vs Frequency (RFC to J2 Insertion Loss State)

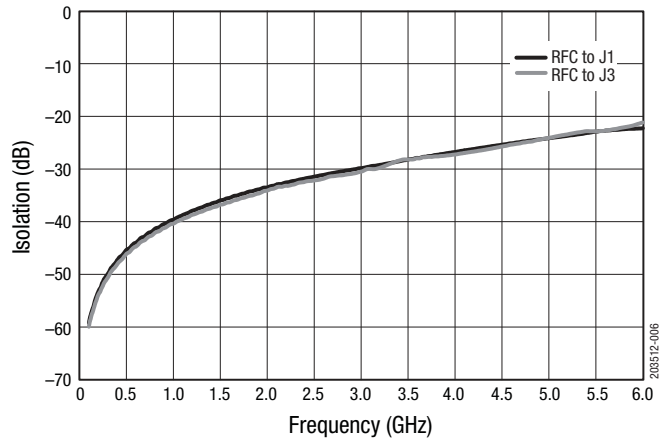
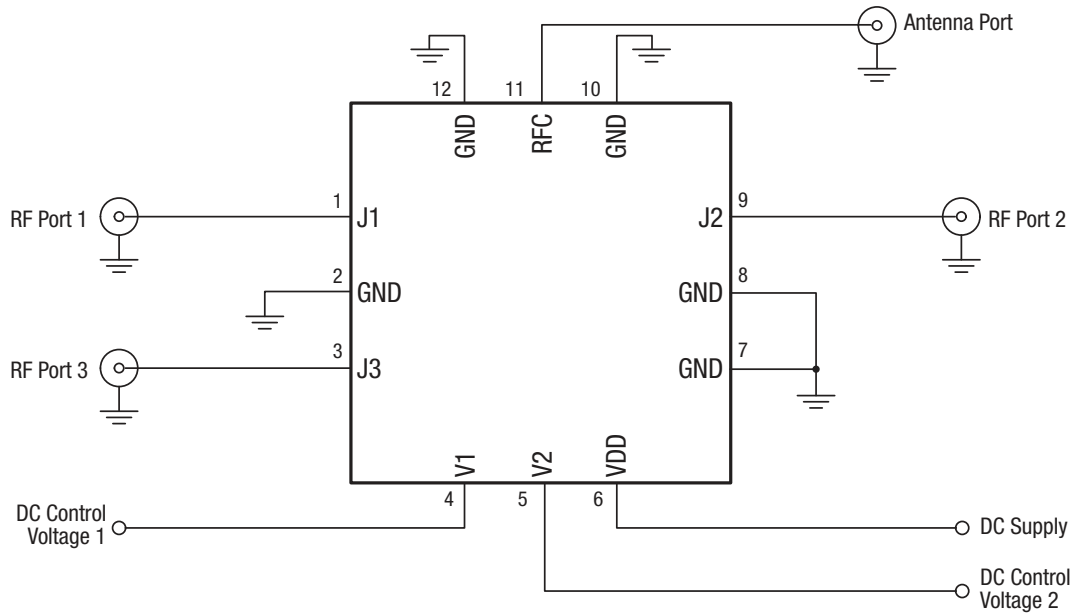

Figure 6. Typical Isolation vs Frequency (RFC to J3 Insertion Loss State)

Evaluation Board Description

The SKY13588-460LF Evaluation Board is used to test the performance of the SKY13588-460LF SP3T switch. The board is made from a two-layer construction with ½ oz. copper cladding on top and bottom. The first layer material is 12-mil Rogers 4003C. The second layer material is 49 mils of FR4 for a total board thickness of about 62 mils. The impedance of all RF traces is 50 Ω.

An Evaluation Board schematic diagram is provided in Figure 7. An assembly drawing for the Evaluation Board is shown in Figure 8.



203512-007

Figure 7. SKY13588-460LF Evaluation Board Schematic

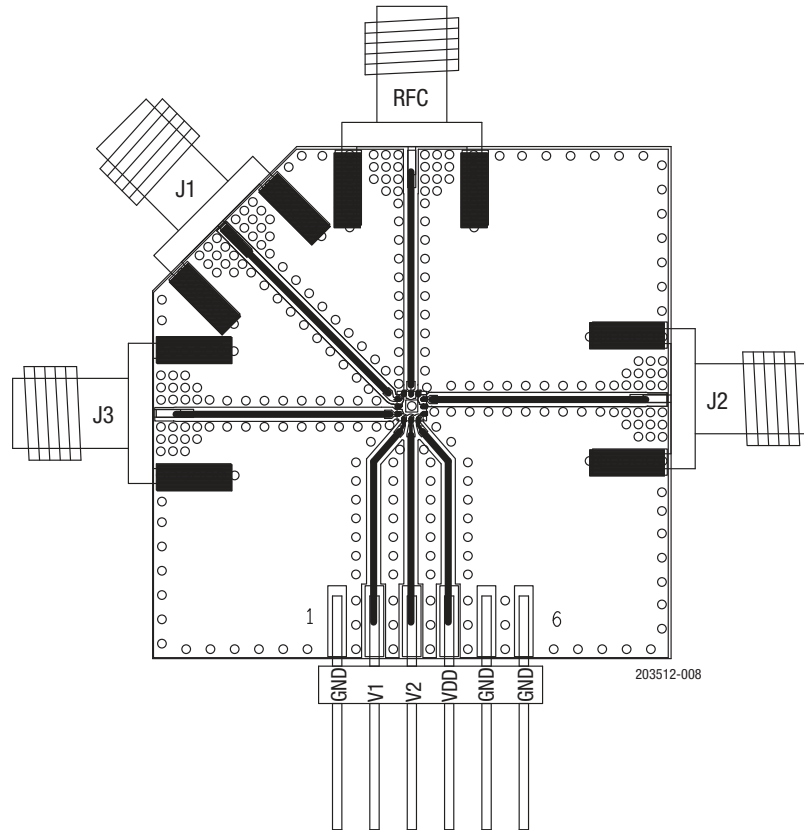

Figure 8. SKY13588-460LF Evaluation Board Assembly Diagram

Package Dimensions

The PCB layout footprint for the SKY13588-460LF is provided in Figure 9. Typical part markings are shown in Figure 10. Package dimensions are shown in Figure 11, and tape and reel dimensions are provided in Figure 12.

Package and Handling Information

Instructions on the shipping container label regarding exposure to moisture after the container seal is broken must be followed. Otherwise, problems related to moisture absorption may occur when the part is subjected to high temperature during solder assembly.

The SKY13588-460LF is rated to Moisture Sensitivity Level 1 (MSL1) at 260 °C. It can be used for lead or lead-free soldering. For additional information, refer to the Skyworks Application Note, *Solder Reflow Information*, document number 200164.

Care must be taken when attaching this product, whether it is done manually or in a production solder reflow environment. Production quantities of this product are shipped in a standard tape and reel format.

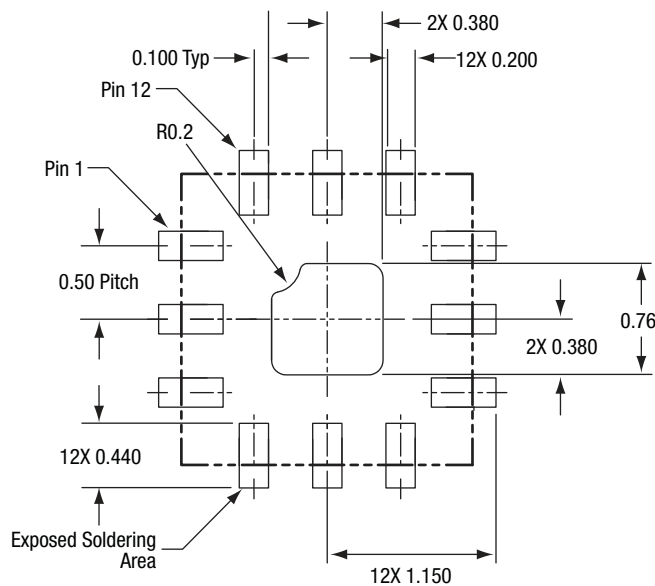

All measurements in millimeters

203512-009

Figure 9. SKY13588-460LF PCB Layout Footprint (Top View)

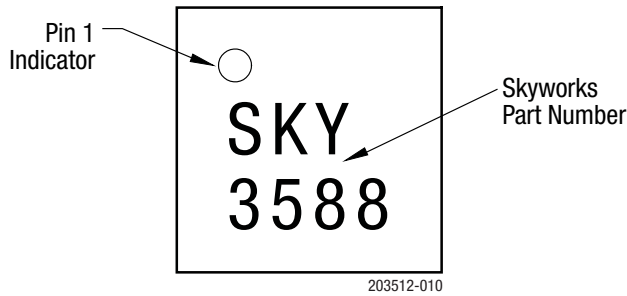
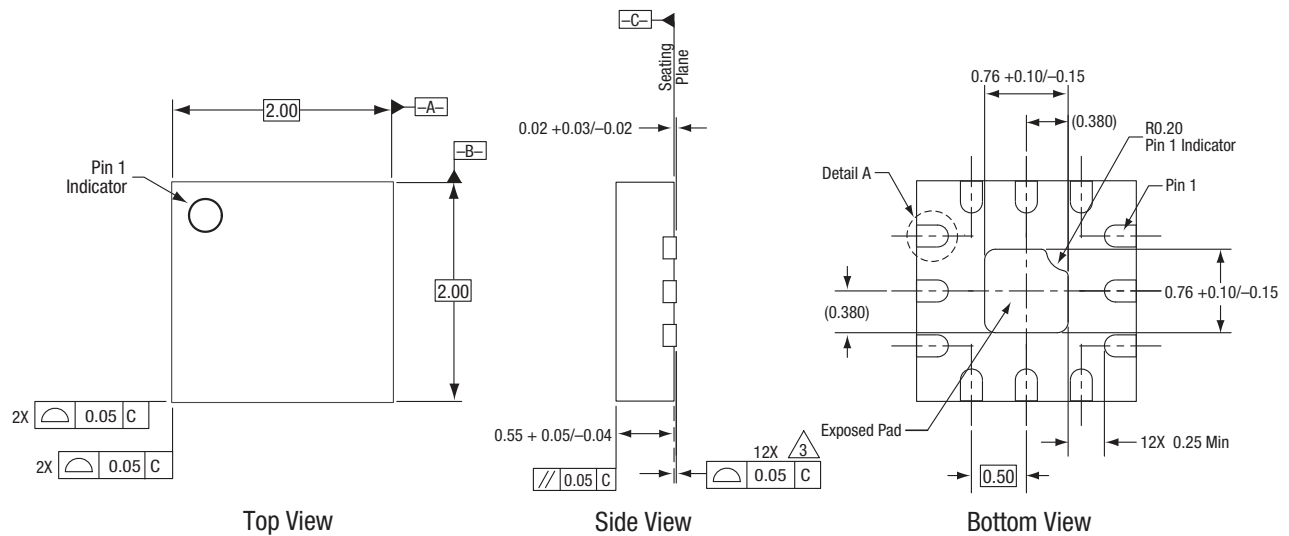
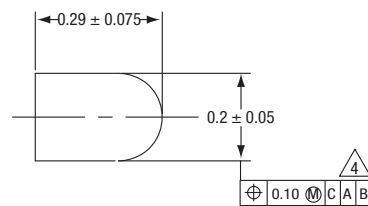

Figure 10. Typical Part Markings (Top View)



Notes:

1. All measurements are in millimeters.
2. Dimensions and tolerances according to ASME Y14.5M-1994.
3. Coplanarity applies to the terminals and all other bottom surface metallization.
4. Dimension applies to metallized terminal. If the terminal has a radius on its end, the width dimension should not be measured in that radius area.



Detail A
Scale: 100X
12 Places

203512-011

Figure 11. SKY13588-460LF Package Dimensions

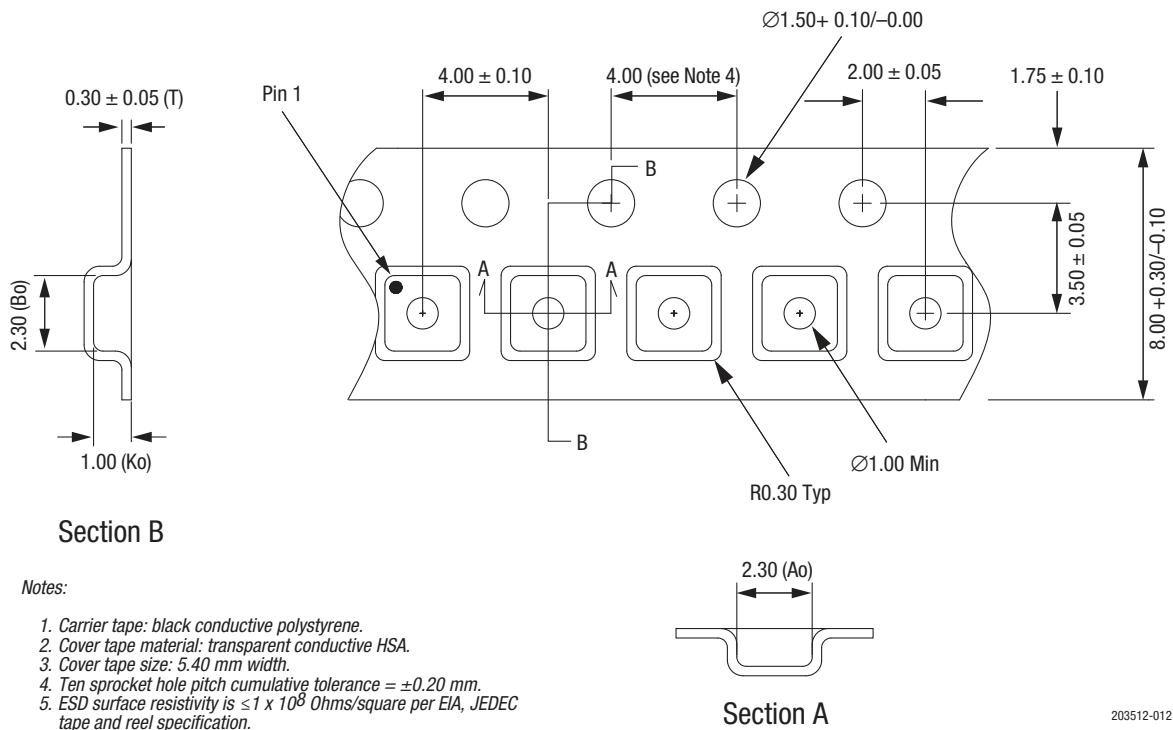

Figure 12. SKY13588-460LF Tape and Reel Dimensions

Ordering Information

Model Name	Manufacturing Part Number	Evaluation Board Part Number
SKY13588-460LF: SP3T Switch	SKY13588-460LF	SKY13588-460LF-EVB

Copyright © 2015-2017 Skyworks Solutions, Inc. All Rights Reserved.

Information in this document is provided in connection with Skyworks Solutions, Inc. ("Skyworks") products or services. These materials, including the information contained herein, are provided by Skyworks as a service to its customers and may be used for informational purposes only by the customer. Skyworks assumes no responsibility for errors or omissions in these materials or the information contained herein. Skyworks may change its documentation, products, services, specifications or product descriptions at any time, without notice. Skyworks makes no commitment to update the materials or information and shall have no responsibility whatsoever for conflicts, incompatibilities, or other difficulties arising from any future changes.

No license, whether express, implied, by estoppel or otherwise, is granted to any intellectual property rights by this document. Skyworks assumes no liability for any materials, products or information provided hereunder, including the sale, distribution, reproduction or use of Skyworks products, information or materials, except as may be provided in Skyworks Terms and Conditions of Sale.

THE MATERIALS, PRODUCTS AND INFORMATION ARE PROVIDED "AS IS" WITHOUT WARRANTY OF ANY KIND, WHETHER EXPRESS, IMPLIED, STATUTORY, OR OTHERWISE, INCLUDING FITNESS FOR A PARTICULAR PURPOSE OR USE, MERCHANTABILITY, PERFORMANCE, QUALITY OR NON-INFRINGEMENT OF ANY INTELLECTUAL PROPERTY RIGHT; ALL SUCH WARRANTIES ARE HEREBY EXPRESSLY DISCLAIMED. SKYWORKS DOES NOT WARRANT THE ACCURACY OR COMPLETENESS OF THE INFORMATION, TEXT, GRAPHICS OR OTHER ITEMS CONTAINED WITHIN THESE MATERIALS. SKYWORKS SHALL NOT BE LIABLE FOR ANY DAMAGES, INCLUDING BUT NOT LIMITED TO ANY SPECIAL, INDIRECT, INCIDENTAL, STATUTORY, OR CONSEQUENTIAL DAMAGES, INCLUDING WITHOUT LIMITATION, LOST REVENUES OR LOST PROFITS THAT MAY RESULT FROM THE USE OF THE MATERIALS OR INFORMATION, WHETHER OR NOT THE RECIPIENT OF MATERIALS HAS BEEN ADVISED OF THE POSSIBILITY OF SUCH DAMAGE.

Skyworks products are not intended for use in medical, lifesaving or life-sustaining applications, or other equipment in which the failure of the Skyworks products could lead to personal injury, death, physical or environmental damage. Skyworks customers using or selling Skyworks products for use in such applications do so at their own risk and agree to fully indemnify Skyworks for any damages resulting from such improper use or sale.

Customers are responsible for their products and applications using Skyworks products, which may deviate from published specifications as a result of design defects, errors, or operation of products outside of published parameters or design specifications. Customers should include design and operating safeguards to minimize these and other risks. Skyworks assumes no liability for applications assistance, customer product design, or damage to any equipment resulting from the use of Skyworks products outside of stated published specifications or parameters.

Skyworks and the Skyworks symbol are trademarks or registered trademarks of Skyworks Solutions, Inc., in the United States and other countries. Third-party brands and names are for identification purposes only, and are the property of their respective owners. Additional information, including relevant terms and conditions, posted at www.skyworksinc.com, are incorporated by reference.