



MICROCHIP

ADM00879
Demonstration Board
User's Guide

Note the following details of the code protection feature on Microchip devices:

- Microchip products meet the specification contained in their particular Microchip Data Sheet.
- Microchip believes that its family of products is one of the most secure families of its kind on the market today, when used in the intended manner and under normal conditions.
- There are dishonest and possibly illegal methods used to breach the code protection feature. All of these methods, to our knowledge, require using the Microchip products in a manner outside the operating specifications contained in Microchip's Data Sheets. Most likely, the person doing so is engaged in theft of intellectual property.
- Microchip is willing to work with the customer who is concerned about the integrity of their code.
- Neither Microchip nor any other semiconductor manufacturer can guarantee the security of their code. Code protection does not mean that we are guaranteeing the product as "unbreakable."

Code protection is constantly evolving. We at Microchip are committed to continuously improving the code protection features of our products. Attempts to break Microchip's code protection feature may be a violation of the Digital Millennium Copyright Act. If such acts allow unauthorized access to your software or other copyrighted work, you may have a right to sue for relief under that Act.

Information contained in this publication regarding device applications and the like is provided only for your convenience and may be superseded by updates. It is your responsibility to ensure that your application meets with your specifications. MICROCHIP MAKES NO REPRESENTATIONS OR WARRANTIES OF ANY KIND WHETHER EXPRESS OR IMPLIED, WRITTEN OR ORAL, STATUTORY OR OTHERWISE, RELATED TO THE INFORMATION, INCLUDING BUT NOT LIMITED TO ITS CONDITION, QUALITY, PERFORMANCE, MERCHANTABILITY OR FITNESS FOR PURPOSE. Microchip disclaims all liability arising from this information and its use. Use of Microchip devices in life support and/or safety applications is entirely at the buyer's risk, and the buyer agrees to defend, indemnify and hold harmless Microchip from any and all damages, claims, suits, or expenses resulting from such use. No licenses are conveyed, implicitly or otherwise, under any Microchip intellectual property rights unless otherwise stated.

Microchip received ISO/TS-16949:2009 certification for its worldwide headquarters, design and wafer fabrication facilities in Chandler and Tempe, Arizona; Gresham, Oregon and design centers in California and India. The Company's quality system processes and procedures are for its PIC® MCUs and dsPIC® DSCs, KEELOQ® code hopping devices, Serial EEPROMs, microperipherals, nonvolatile memory and analog products. In addition, Microchip's quality system for the design and manufacture of development systems is ISO 9001:2000 certified.

**QUALITY MANAGEMENT SYSTEM
CERTIFIED BY DNV
= ISO/TS 16949 =**

Trademarks

The Microchip name and logo, the Microchip logo, AnyRate, AVR, AVR logo, AVR Freaks, BeaconThings, BitCloud, CryptoMemory, CryptoRF, dsPIC, FlashFlex, flexPWR, Helder, JukeBlox, KEELOQ, KEELOQ logo, Klear, LANCheck, LINK MD, maXStylus, maXTouch, MediaLB, megaAVR, MOST, MOST logo, MPLAB, OptoLyzer, PIC, picoPower, PICSTART, PIC32 logo, Prochip Designer, QTouch, RightTouch, SAM-BA, SpyNIC, SST, SST Logo, SuperFlash, tinyAVR, UNI/O, and XMEGA are registered trademarks of Microchip Technology Incorporated in the U.S.A. and other countries.

ClockWorks, The Embedded Control Solutions Company, EtherSynch, Hyper Speed Control, HyperLight Load, IntelliMOS, mTouch, Precision Edge, and Quiet-Wire are registered trademarks of Microchip Technology Incorporated in the U.S.A.

Adjacent Key Suppression, AKS, Analog-for-the-Digital Age, Any Capacitor, AnyIn, AnyOut, BodyCom, chipKIT, chipKIT logo, CodeGuard, CryptoAuthentication, CryptoCompanion, CryptoController, dsPICDEM, dsPICDEM.net, Dynamic Average Matching, DAM, ECAN, EtherGREEN, In-Circuit Serial Programming, ICSP, Inter-Chip Connectivity, JitterBlocker, KlearNet, KlearNet logo, Mindi, MiWi, motorBench, MPASM, MPF, MPLAB Certified logo, MPLIB, MPLINK, MultiTRAK, NetDetach, Omniscient Code Generation, PICDEM, PICDEM.net, PICkit, PICTail, PureSilicon, QMatrix, RightTouch logo, REAL ICE, Ripple Blocker, SAM-ICE, Serial Quad I/O, SMART-I.S., SQI, SuperSwitcher, SuperSwitcher II, Total Endurance, TSHARC, USBCheck, VariSense, ViewSpan, WiperLock, Wireless DNA, and ZENA are trademarks of Microchip Technology Incorporated in the U.S.A. and other countries.

SQTP is a service mark of Microchip Technology Incorporated in the U.S.A.

Silicon Storage Technology is a registered trademark of Microchip Technology Inc. in other countries.

GestIC is a registered trademark of Microchip Technology Germany II GmbH & Co. KG, a subsidiary of Microchip Technology Inc., in other countries.

All other trademarks mentioned herein are property of their respective companies.

© 2018, Microchip Technology Incorporated, All Rights Reserved.
ISBN: 978-1-5224-2988-3

Table of Contents

Preface	5
Chapter 1. Product Overview	
1.1 Introduction	9
1.2 EMC2305 Device Short Overview	9
1.3 EMC1438 Device Short Overview	9
1.4 What Is the ADM00879 Demonstration Board?	9
1.5 ADM00879 Demonstration Board Kit Contents	10
Chapter 2. Installation and Operation	
2.1 Introduction	11
2.2 System Requirements	11
2.3 Microchip Thermal Management Utility GUI Installation	11
Chapter 3. Microchip Thermal Management Utility	
3.1 Introduction	15
3.2 First Launch	15
3.3 Control Toolbar	17
3.3.1 Save/Load Settings	17
3.3.2 Data Acquisition	17
3.3.3 Data Logging	17
3.3.4 Temperature Related Options	17
3.3.5 Fan Related Options	18
3.4 Demo View	19
3.4.1 Demo Options	20
3.4.2 Temperature Charts	21
3.4.3 Fan Driver Tab	24
Chapter 4. Hardware Description	
4.1 ADM00879 Demonstration Board Description	25
4.1.1 Fan Connection Options	26
4.1.2 PWM Fan Driver	26
4.1.3 On-Board Temperature Channels	27
4.1.4 On-Board Demonstration Heat Source and Remote Diode	27
4.1.5 External Temperature Remote Diode Connections	28
4.1.6 Optional Desktop PC Integration	28
Appendix A. Schematics and Layouts	
A.1 Introduction	29
A.2 Board – Schematic – EMC2305 and EMC1438	30
A.3 Board – Schematic – Fan Driver (Fan 1)	31
A.4 Board – Schematic – Fan Driver (Fan 2)	31

ADM00879 Demonstration Board User's Guide

A.5 Board – Schematic – Fan Driver (Fan 3)	32
A.6 Board – Schematic – Fan Driver (Fan 4)	32
A.7 Board – Schematic – Fan Driver (Fan 5)	33
A.8 Board – Schematic – Interface and Power	34
A.9 Board – Schematic – Mechanical	35
A.10 Board – Top Silk	36
A.11 Board – Top Copper and Silk	36
A.12 Board – Top Copper	37
A.13 Board – Bottom Copper	37
A.14 Board – Bottom Copper and Silk	38
A.15 Board – Bottom Silk	38
Appendix B. Bill of Materials (BOM)	39
Worldwide Sales and Service	43

Preface

NOTICE TO CUSTOMERS

All documentation becomes dated, and this manual is no exception. Microchip tools and documentation are constantly evolving to meet customer needs, so some actual dialogs and/or tool descriptions may differ from those in this document. Please refer to our website (www.microchip.com) to obtain the latest documentation available.

Documents are identified with a “DS” number. This number is located on the bottom of each page, in front of the page number. The numbering convention for the DS number is “DSXXXXXXXXA”, where “XXXXXXXX” is the document number and “A” is the revision level of the document.

For the most up-to-date information on development tools, see the MPLAB® IDE online help. Select the Help menu, and then Topics, to open a list of available online help files.

INTRODUCTION

This chapter contains general information that will be useful to know before using the ADM00879 Fan Controller Demonstration Board. Items discussed in this chapter include:

- [Document Layout](#)
- [Conventions Used in this Guide](#)
- [Warranty Registration](#)
- [Recommended Reading](#)
- [The Microchip Web Site](#)
- [Customer Support](#)
- [Document Revision History](#)

DOCUMENT LAYOUT

This document describes how to use the ADM00879 Fan Controller Demonstration Board as a development tool to emulate and debug firmware on a target board. The manual layout is as follows:

- **Chapter 1. “Product Overview”** – Important information about the ADM00879 Fan Controller Demonstration Board.
- **Chapter 2. “Installation and Operation”** – Includes instructions on installing and starting the Microchip Thermal Management Utility application.
- **Chapter 3. “Microchip Thermal Management Utility”** – includes instructions on operating the Thermal Management Utility.
- **Chapter 4. “Hardware Description”** – Contains a detailed description of the ADM00879 Fan Controller Demonstration Board
- **Appendix A. “Schematic and Layouts”** – Shows the schematics and layout diagrams for the ADM00879 Fan Controller Demonstration Board.
- **Appendix B. “Bill of Materials (BOM)”** – Lists the parts used to build the ADM00879 Fan Controller Demonstration Board.

CONVENTIONS USED IN THIS GUIDE

This manual uses the following documentation conventions:

DOCUMENTATION CONVENTIONS

Description	Represents	Examples
Arial font:		
Italic characters	Referenced books	<i>MPLAB® IDE User's Guide</i>
	Emphasized text	...is the <i>only</i> compiler...
Initial caps	A window	the Output window
	A dialog	the Settings dialog
	A menu selection	select Enable Programmer
Quotes	A field name in a window or dialog	"Save project before build"
Underlined, italic text with right angle bracket	A menu path	<u><i>File</i></u> >Save
Bold characters	A dialog button	Click OK
	A tab	Click the Power tab
N'Rnnnn	A number in verilog format, where N is the total number of digits, R is the radix and n is a digit.	4'b0010, 2'hF1
Text in angle brackets < >	A key on the keyboard	Press <Enter>, <F1>
Courier New font:		
Plain Courier New	Sample source code	#define START
	Filenames	autoexec.bat
	File paths	c:\mcc18\h
	Keywords	_asm, _endasm, static
	Command-line options	-Opa+, -Opa-
	Bit values	0, 1
	Constants	0xFF, 'A'
Italic Courier New	A variable argument	<i>file.o</i> , where <i>file</i> can be any valid filename
Square brackets []	Optional arguments	mcc18 [options] <i>file</i> [options]
Curly brackets and pipe character: { }	Choice of mutually exclusive arguments; an OR selection	errorlevel {0 1}
Ellipses...	Replaces repeated text	var_name [, var_name...]
	Represents code supplied by user	void main (void) { ... }

WARRANTY REGISTRATION

Please complete the enclosed Warranty Registration Card and mail it promptly. Sending in the Warranty Registration Card entitles users to receive new product updates. Interim software releases are available at the Microchip web site.

RECOMMENDED READING

This user's guide describes how to use the ADM00879 Fan Controller Demonstration Board. Other useful documents are listed below. The following Microchip document is available and recommended as a supplemental reference resource:

EMC1438 Data Sheet – “1°C Multiple Temperature Sensor with Hardware Controlled Standby and Hottest of Multiple Zones” (DS20005513A)

THE MICROCHIP WEB SITE

Microchip provides online support via our web site at www.microchip.com. This web site is used as a means to make files and information easily available to customers. Accessible by using your favorite Internet browser, the website contains the following information:

- **Product Support** – Data sheets and errata, application notes and sample programs, design resources, user's guides and hardware support documents, latest software releases and archived software
- **General Technical Support** – Frequently Asked Questions (FAQs), technical support requests, online discussion groups, Microchip consultant program member listing
- **Business of Microchip** – Product selector and ordering guides, latest Microchip press releases, listing of seminars and events, listings of Microchip sales offices, distributors and factory representatives

PRODUCT CHANGE NOTIFICATION SERVICE

Microchip's customer notification service helps keep customers current on Microchip products. Subscribers will receive e-mail notifications whenever there are changes, updates, revisions or errata related to a specified product family or development tool of interest.

To register, access the Microchip web site at www.microchip.com, click on **Product Change Notification** and follow the registration instructions.

CUSTOMER SUPPORT

Users of Microchip products can receive assistance through several channels:

- Distributor or Representative
- Local Sales Office
- Field Application Engineer (FAE)
- Technical Support

Customers should contact their distributor, representative or field application engineer (FAE) for support. Local sales offices are also available to help customers. A listing of sales offices and locations is included in the back of this document.

Technical support is available through the web site at:
<http://www.microchip.com/support>.

DOCUMENT REVISION HISTORY

Revision A (May 2018)

- Initial Release of this Document.

Chapter 1. Product Overview

1.1 INTRODUCTION

This chapter provides an overview of the ADM00879 Fan Controller Demonstration Board and covers the following topics:

- EMC2305 Device Short Overview
- EMC1438 Device Short Overview
- What Is the ADM00879 Demonstration Board?
- ADM00879 Demonstration Board Kit Contents

1.2 EMC2305 DEVICE SHORT OVERVIEW

The EMC2305 device is an SMBus (System Management Bus) compliant and I²C (Inter-integrated Circuit) compatible fan controller, with up to five independently controlled PWM (Pulse Width Modulation) fan drivers. Each fan driver is controlled by a programmable frequency PWM driver and FSC (Fan Speed Control) algorithm, which operates in either a closed loop fashion or as a directly PWM-controlled device.

The closed loop FSC algorithm has the capability to detect aging fans and alert the system. Likewise, it detects stalled or locked fans and triggers an interruption.

1.3 EMC1438 DEVICE SHORT OVERVIEW

The EMC1438 device is a high-accuracy, low-cost, SMBus temperature sensor (I²C compatible). Advanced features such as Resistance Error Correction (REC), Beta Compensation and automatic diode type detection combine to provide a robust solution for complex environmental-monitoring applications.

EMC1438 monitors up to eight temperature channels (up to seven external and one internal). The device provides $\pm 1^{\circ}\text{C}$ accuracy for the internal and external diode temperatures.

1.4 WHAT IS THE ADM00879 DEMONSTRATION BOARD?

The ADM00879 Fan Controller Demonstration Board provides an example of a fan-control application, by using the EMC2305 fan controller and EMC1438 temperature sensor. There are 5 fan channels, 2 on-board temperature sensors and 6 remote temperature sensor inputs available.

The low-voltage circuits are powered from either the micro USB connector or the 2.1 mm Jack for 12V fan supply (power adapter not included), making it possible to run the PC application and set all the parameters without powering the fan drivers. Test points for the 12V input are also available.

I²C communication is provided over USB using the on-board MCP2221 USB to I²C bridge. The Thermal Management Utility graphic user interface (GUI) automatically detects the board and loads the appropriate interface.

An on-board heat source with 4 heat levels is provided for demonstrative purposes.

The demonstration GUI is equipped with options to manually setup all the parameters for the thermal sensor and the fan controller. The GUI also provides a fully automatic temperature control interface, where any fan channel can be linked to any temperature channel.

1.5 ADM00879 DEMONSTRATION BOARD KIT CONTENTS

The ADM00879 Demonstration Board kit includes the following:

- One ADM00879 Fan Controller Demonstration Board
- Important Information Sheet
- USB cable
- Two NPN transistors in TO-92 package to be used as remote temperature diodes.

Note: An additional power supply or bench supply is needed for powering the fans.

Chapter 2. Installation and Operation

2.1 INTRODUCTION

This section describes how to install the Microchip Thermal Management Utility GUI, required in order to interact with the ADM00879 Demonstration Board.

2.2 SYSTEM REQUIREMENTS

The ADM00879 Demonstration Board is designed to be used with a personal computer (desktop or laptop) running Microsoft® Windows® 7 or later. For USB connectivity, the minimal physical requirement for the PC is a standard type-A USB 2.0 port.

2.3 MICROCHIP THERMAL MANAGEMENT UTILITY GUI INSTALLATION

Go to www.microchip.com and search for EMC2305 or EMC1438 and download the Thermal Management Utility (version 1.5.6 or newer).

If an older version of the software is already installed, you have to remove it before installing the new one.

Follow the next steps to proceed with the installation.

FIGURE 2-1: THERMAL MANAGEMENT UTILITY – SETUP WINDOW

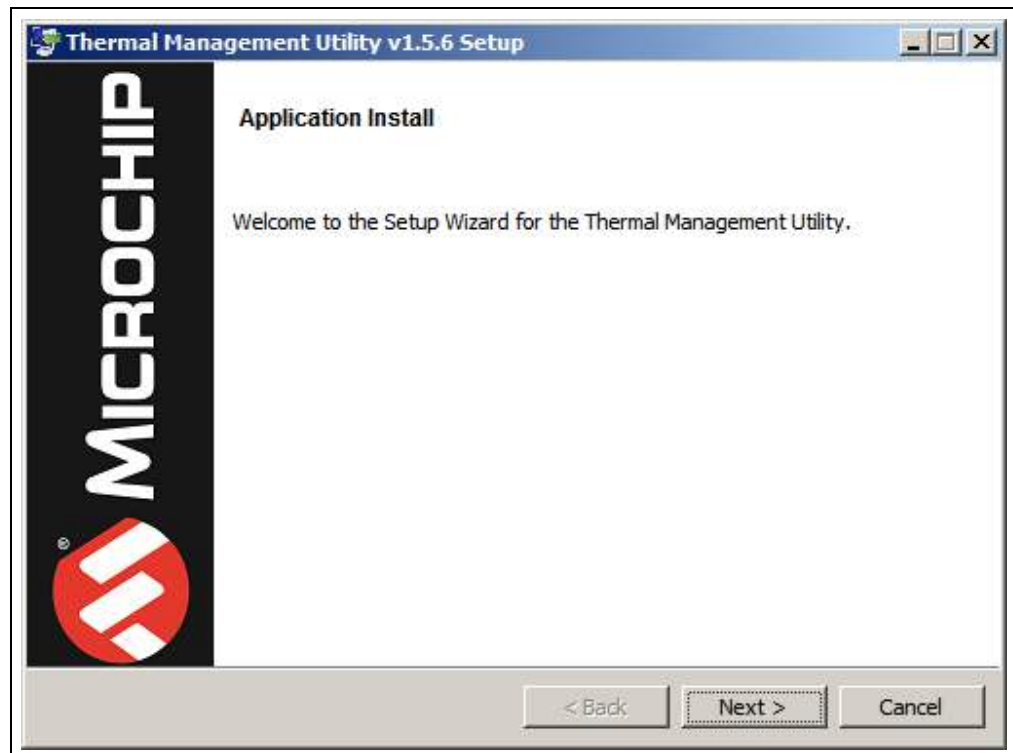

Click the **Next** button to continue.

FIGURE 2-2: THERMAL MANAGEMENT UTILITY – LICENSE AGREEMENT WINDOW

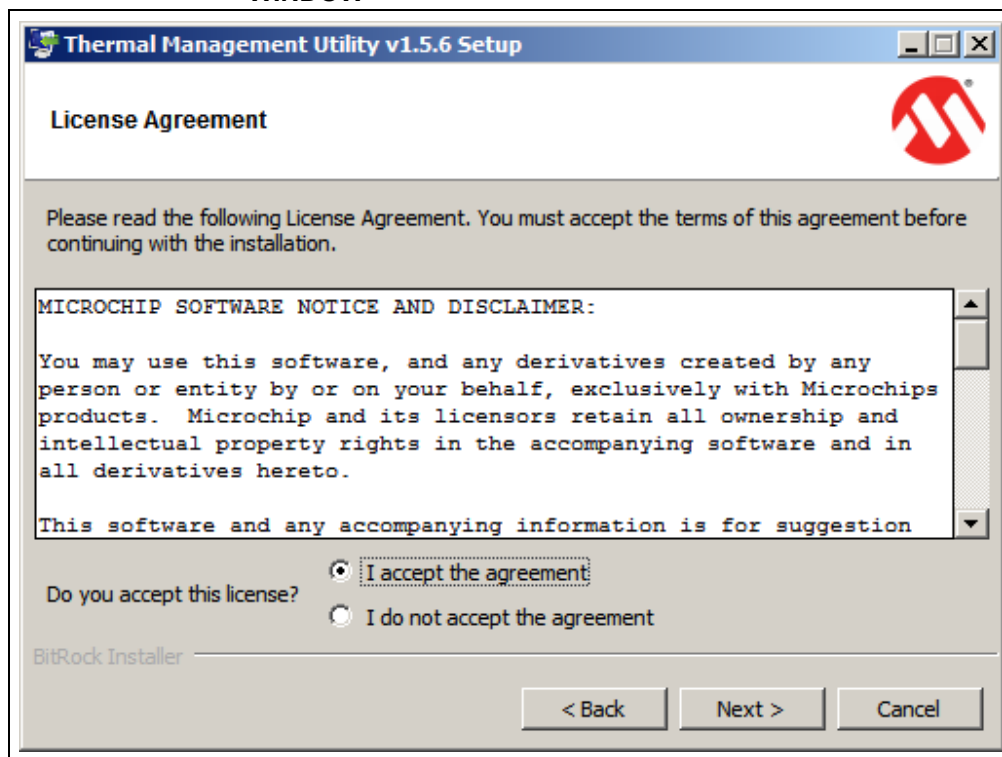

Read and accept the License Agreement. Click the **Next** button to proceed.

FIGURE 2-3: THERMAL MANAGEMENT UTILITY – INSTALLATION DIRECTORY WINDOW

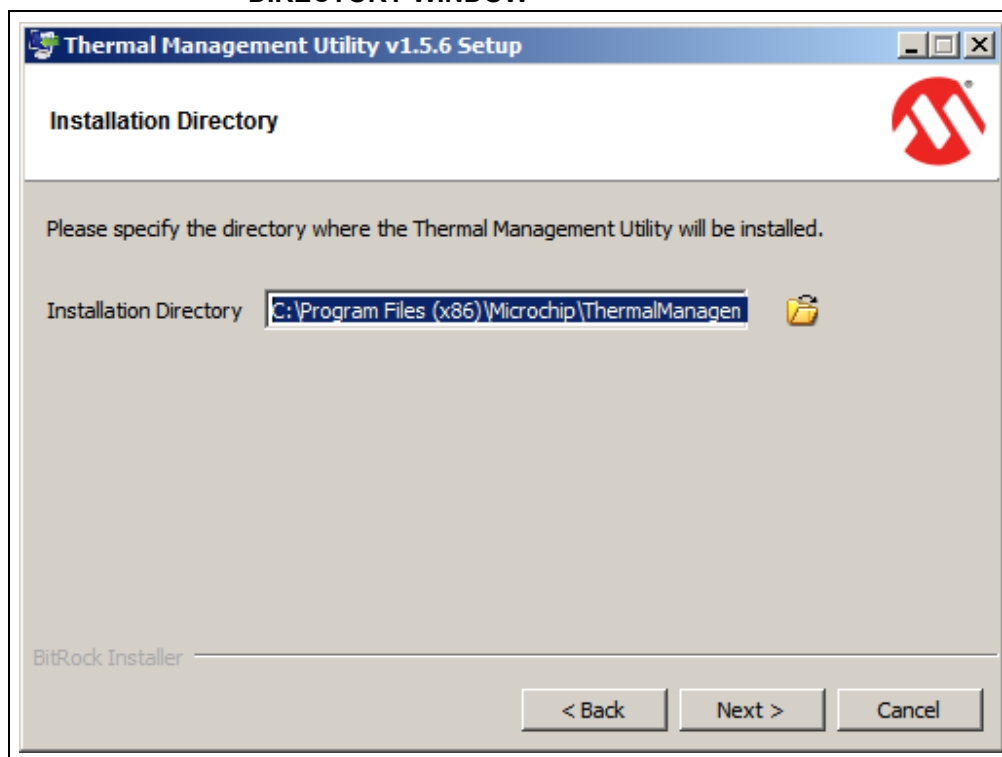

Choose the desired installation directory and click **Next**.

FIGURE 2-4: THERMAL MANAGEMENT UTILITY – READY TO INSTALL WINDOW

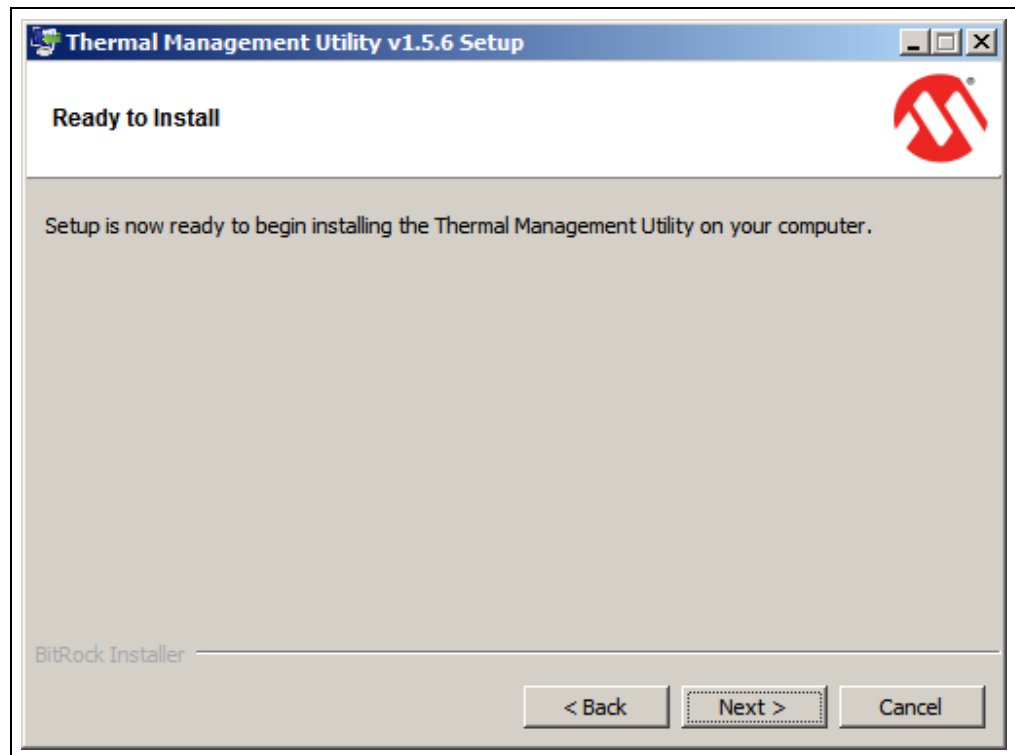

Once the installation directory has been chosen, click **Next** to begin the installation.

FIGURE 2-5: THERMAL MANAGEMENT UTILITY – INSTALLING WINDOW

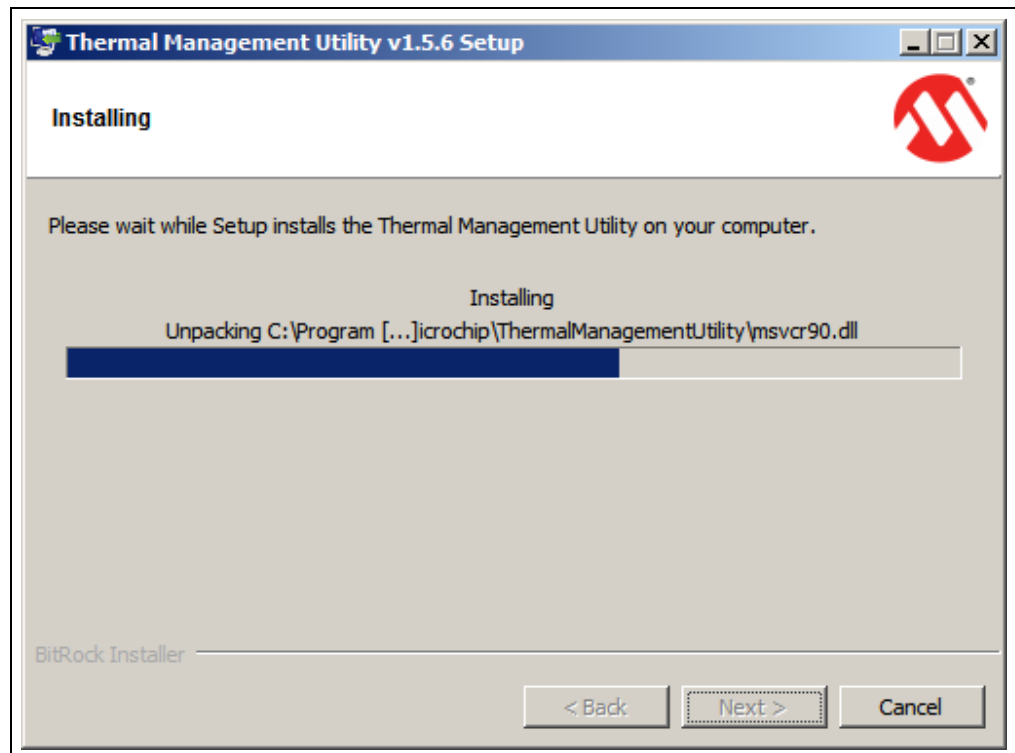

Wait for the setup wizard to finish the installation.

FIGURE 2-6: THERMAL MANAGEMENT UTILITY – INSTALL COMPLETE WINDOW

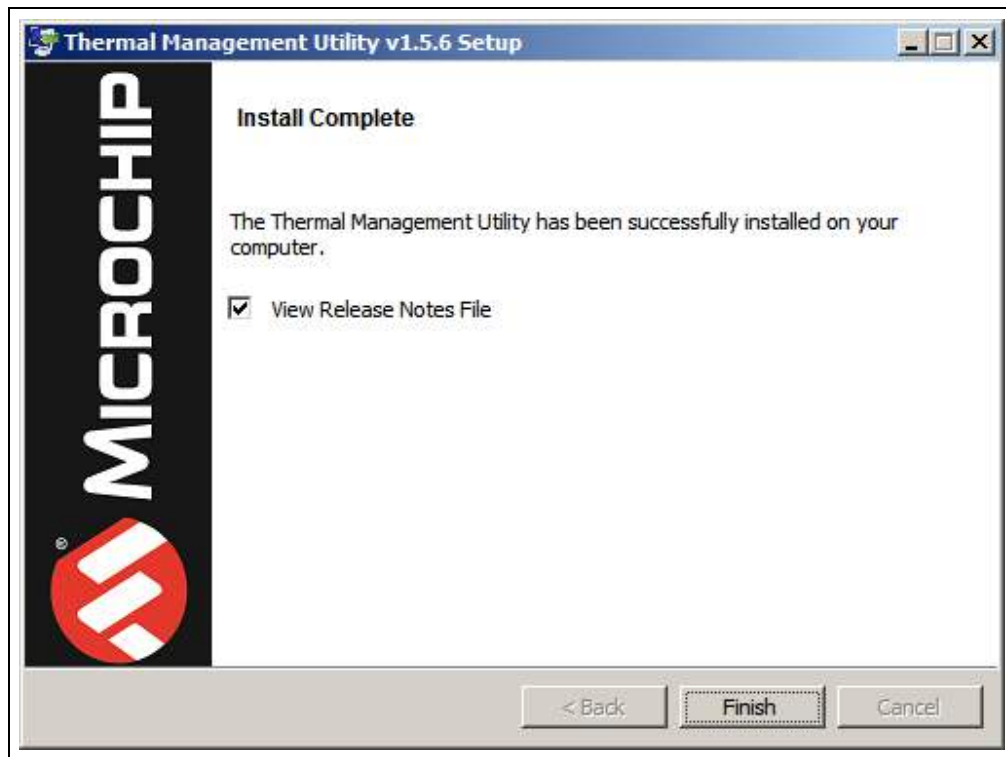

Once the installation is completed, click **Finish** to exist the setup wizard.

Chapter 3. Microchip Thermal Management Utility

3.1 INTRODUCTION

The Microchip Thermal Management Utility GUI allows the user to evaluate the EMC2305 and EMC1438 devices for temperature and fan control applications.

3.2 FIRST LAUNCH

The ADM00879 Demonstration Board is required, in order to start the graphical user interface.

When the GUI is launched for the first time after the installation, or a new board is connected, it contains the fan driver and the temperature sensor currently set values. To use the Demo mode, as described in [Section 3.4 “Demo View”](#), the proper settings must be loaded. The installer automatically adds the `ADM00879_Default_Settings.bin` file in the `C:\Users\\Documents\ThermalManagementUtility\Board Settings` folder. Use the **Load** button from the top menu to open the file and apply these settings to your board.

Once the hardware is connected, the software recognizes the device ID and displays the corresponding GUI for the ADM00879 Fan Controller Demonstration Board. When a board is connected, its fan driver and temperature sensor settings are read and displayed in the GUI.

Disconnecting the USB will close the GUI and display a Hardware Not Detected dialog box, as displayed in [Figure 3-1](#).

FIGURE 3-1: HARDWARE NOT CONNECTED DIALOG BOX

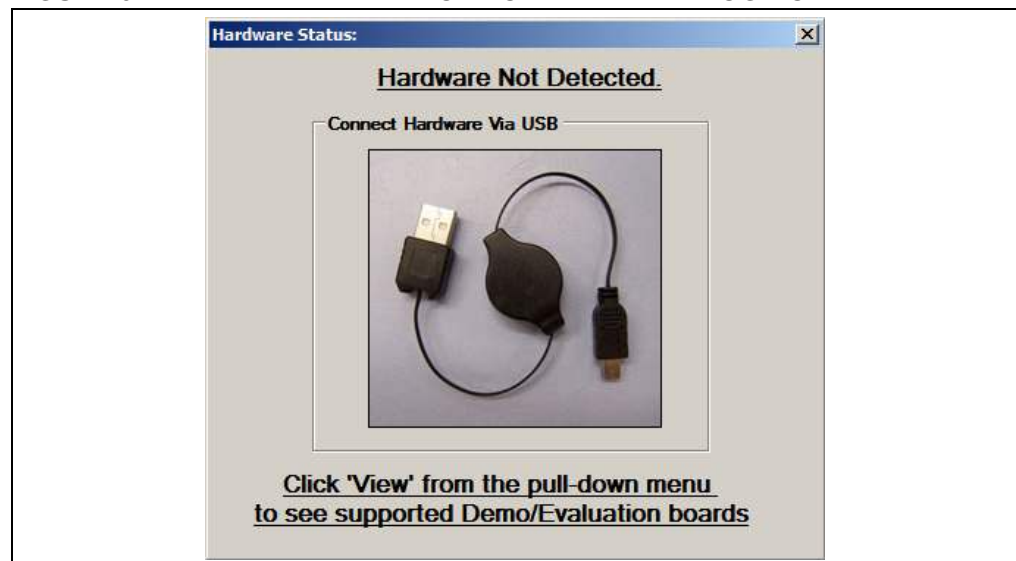

The Thermal Management Utility main window ([Figure 3-2](#)) consists of a Control Toolbar (marked in [Figure 3-2](#) with the number 1), a View Selection section (marked by the number 2), a Demo Options section (3) and a Temperature/RPM Plots section (4).

FIGURE 3-2: THERMAL MANAGEMENT UTILITY MAIN WINDOW

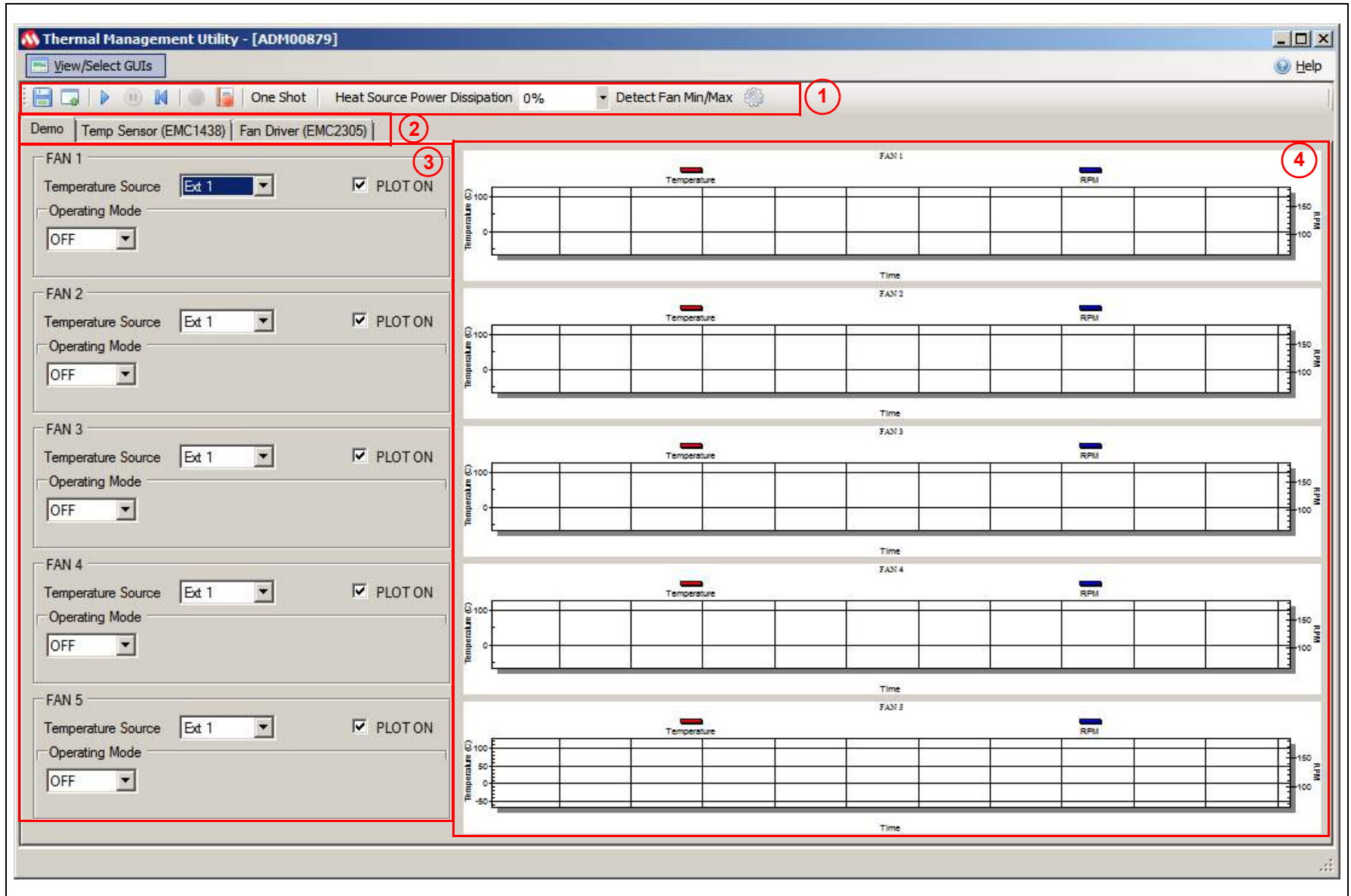

3.3 CONTROL TOOLBAR

FIGURE 3-3: CONTROL TOOLBAR SECTION

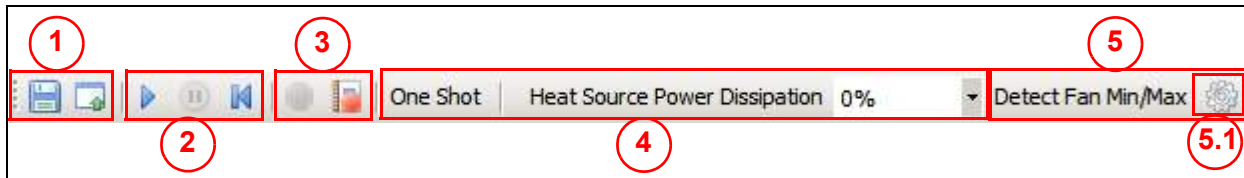

3.3.1 Save/Load Settings

The Save/Load Settings section is noted in [Figure 3-3](#) with the number 1. This section allows the saving of all the currently configured GUI settings. The settings will be stored in a *file.bin* file and can be reloaded to reconfigure the board. The loading process repopulates all the available fields and writes the settings into the connected ADM00879 Demonstration Board. This process takes up to 30 seconds to complete.

3.3.2 Data Acquisition

The Data Acquisition section (noted in [Figure 3-3](#) with the number 2) provides controls for starting, stopping and resetting the chart data.

Starting the data capture provides continuous reading of data from the temperature sensor and fan driver, updates the charts and activates the Demo View functionality. When data capture is stopped, the three demonstration modes (auto, constant and manual) are not operational.

The **Reset Plot Data** button clears the data from any visible chart in the currently selected view.

3.3.3 Data Logging

The Data Logging section (number 3) enables or disables the data logging. Clicking the **Record Acquisition** button opens a file selection window, where the destination of the log file can be set. The logs are saved as *file.txt* files and contain the temperature readings for all of the EMC1438's channels.

3.3.4 Temperature Related Options

The Temperature Related Options section is marked in [Figure 3-3](#) with the number 4.

The **One Shot** button writes to the One Shot Register of the EMC1438's temperature sensor. This can be used to trigger an update for the temperature measurements when the device is in Standby mode. To view the measurements, click the **Update Registers** button from the Temp Sensor tab. In Active mode, the functionality of the **One Shot** button is disabled.

The Heat Source Power Dissipation controls the on-board heat source connected to channel 1 of the temperature sensor. [Table 3-1](#) shows the approximate temperatures that can be reached when heating is enabled.

TABLE 3-1: HEAT SOURCE TEMPERATURES

Heat %	Temperature (°C)	
	Fan 1 – OFF	Fan 1 – 100%
0	Ambient temperature	–
25	33–33.5	30.5–0.75

TABLE 3-1: HEAT SOURCE TEMPERATURES (CONTINUED)

Heat %	Temperature (°C)	
	Fan 1 – OFF	Fan 1 – 100%
50	40.875–41.125	34.75–35
75	50–51	38.875–39.125
100	60–61	44.25–44.5

3.3.5 Fan Related Options

The Fan Related Options section is marked by the number 5.

The **Detect Fan Min/Max** button opens a dialog box (Figure 3-4), which allows the detection of the minimum and maximum RPM (Revolutions Per Minute) values for one or several connected fans. Each selected fan is initially set to the minimum drive value (configured in the **Fan Driver** tab, under the Min Drive percentage field), the RPM being measured subsequently. If the fan doesn't start, then the Min Drive percentage needs to be increased with the selected Accuracy step, until the fan starts. After the minimum RPM, Valid Tachometer count and minimum Drive values are determined, they are stored. In order to determine the maximum RPM value, the fan drive is set to 100% and the RPM is measured. Note that, considering that some fans reach their rated maximum speed after a longer run time, the maximum RPM value detected can be slightly lower than the fan specification.

FIGURE 3-4: DETERMINE FAN MIN/MAX RPM DIALOG BOX

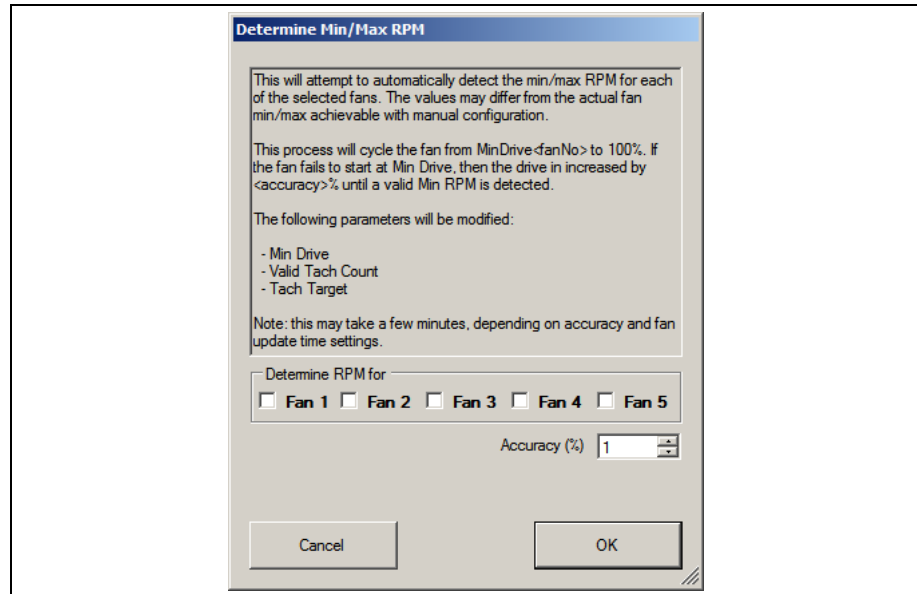

The **Demo RPM Offset** button (marked as 5.1 in Figure 3-3) opens a dialog box (Figure 3-5), where the Min RPM offset values can be configured. This relates only to the fan control algorithm implemented in software for the demo application example. For the Auto and Constant demo modes, the algorithm uses a minimum RPM target that consists of the minimum RPM value specified in the fan configuration tab (Figure 3-15, number 6) summed with the Offset value. Due to the RPM jitter, if the fan target is set to the Min RPM value, a false fan stall detection may occur, causing the fan to be sped up unnecessarily, as the drive level used for the initial spin-up (Figure 3-15, number 5) has a minimum value of 30% (which is larger than the Min Drive setting).

This jitter is fan dependent, so each fan channel has its own offset value. The required offset value can be identified using the Fan Configuration or the Manual mode, which can drive the fan target up to the Min RPM value.

FIGURE 3-5: DEMO SETTINGS DIALOG BOX

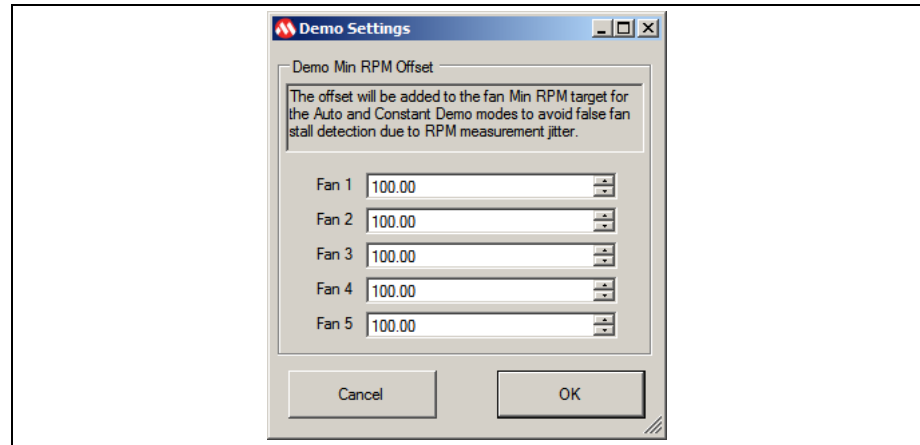

3.4 DEMO VIEW

The Demo View section (Figure 3-6) consists of a Demo Options area (1) and a Temp/RPM Charts area (2).

FIGURE 3-6: DEMO VIEW SECTION



3.4.1 Demo Options

This section provides control over the operating mode of each fan and its associated temperature source.

FIGURE 3-7: DEMO OPTIONS FAN 1

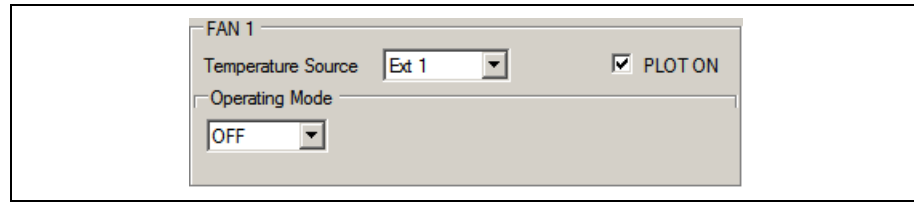

3.4.1.1 TEMPERATURE SOURCE

Each fan can be configured to monitor one of the eight available temperature channels of the EMC1438 device. The Ext1 channel is tied to the on-board heat source.

3.4.1.2 OPERATING MODE

This demonstration offers three main operating modes: Auto, Constant and Manual. The Auto and Constant modes are implemented in software by reading the temperature from the EMC1438 device and adjusting the fan speed based on this input.

In Auto Mode, the fan speed is adjusted as follows:

- If the temperature is below the minimum temperature value, the fan is turned OFF.
- If the temperature is between the minimum and maximum values, the fan runs at the minimum RPM value summed with the Offset value.
- When the temperature exceeds the maximum value, the fan speed is adjusted, in order to keep the temperature at the maximum limit, with a hysteresis of $\pm 0.125^{\circ}\text{C}$. This outcome is dependent on the cooling solution (appropriate heat sink to dissipate the heat).

FIGURE 3-8: DEMO OPTIONS FAN 1 – AUTO MODE

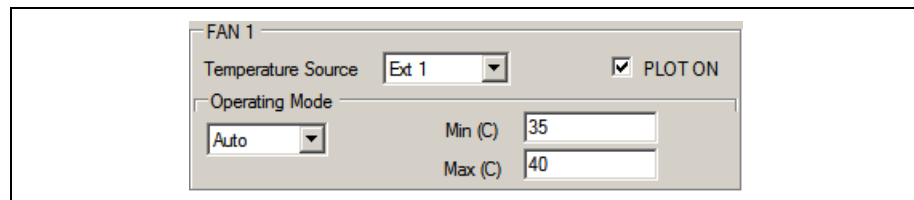

In Constant Mode, the fan speed is adjusted as follows:

- If the temperature is below the target temperature value, the fan is running at the minimum RPM value summed with the Offset value.
- When the temperature exceeds the target value, the fan speed is adjusted, in order to keep the temperature at the target limit with a hysteresis of $\pm 0.125^{\circ}\text{C}$. This outcome is dependent on the cooling solution (appropriate heat sink to dissipate the heat).

FIGURE 3-9: DEMO OPTIONS FAN 1 – CONSTANT MODE

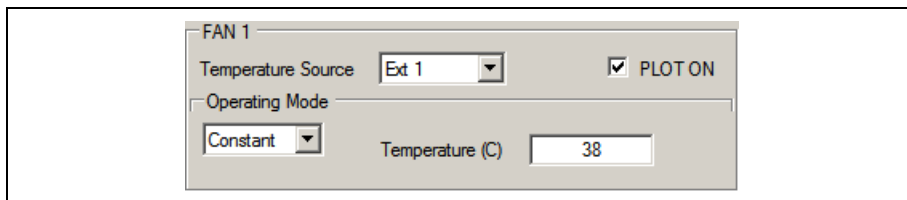

In Manual Mode, the fan RPM can be adjusted from minimum to maximum, by using the slider or by directly writing in the designated RPM field. The fan can be stopped by checking the Fan OFF check-box.

When setting the target to minimum RPM in Manual Mode, the fan can start to oscillate. This mode uses the driver's fan speed algorithm, so if the target is set at the minimum RPM value and the RPM goes slightly below this value (thus going over the Valid Tachometer value), a fan stall condition is detected and the driver starts to spin up the fan.

This spin-up is occurring because the minimum PWM duty cycle for the initial spin-up (or a fan stall condition) is at 30%, while the minimum rated fan speed is at 16% duty cycle. In the current demonstration configuration, this relates to a minimum fan spin-up voltage of 9.5V.

FIGURE 3-10: DEMO OPTIONS FAN 1 – MANUAL MODE

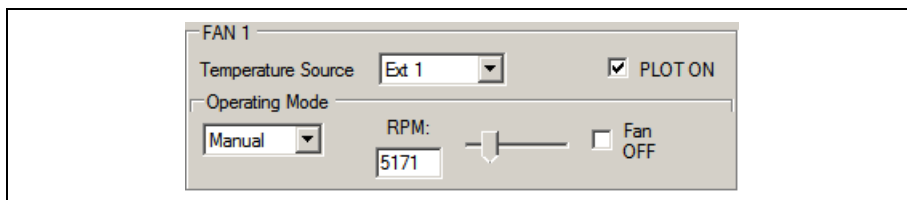

3.4.2 Temperature Charts

This section displays the fan RPM and its corresponding heat source value (°C). The chart visibility can be toggled from the corresponding fan Plot On check box, located in the Demo Options section ([Figure 3-6](#)).

For a better visibility of the plotted values, a data table can be enabled from the chart's context menu. Right Click on the plot in order to trigger this menu and select the Both Graph and Table option, as displayed in [Figure 3-11](#).

FIGURE 3-11: CHART OPTIONS

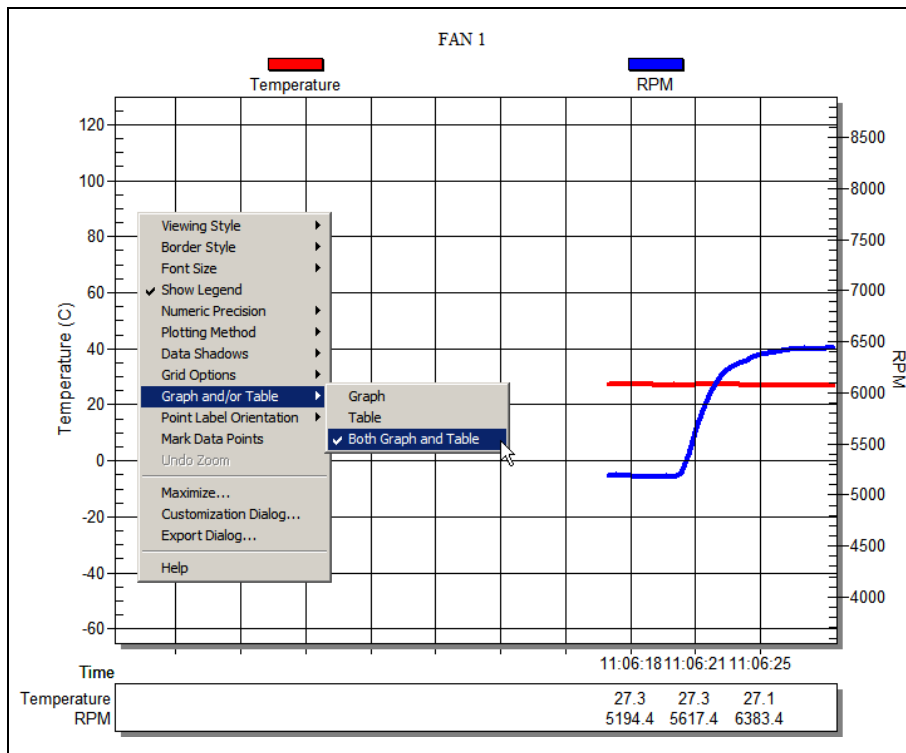

3.4.2.1 TEMPERATURE SENSOR (EMC1438) VIEW

This view contains all values and settings related to the on-board temperature sensor.

FIGURE 3-12: TEMPERATURE SENSOR VIEW – TEMPERATURES TAB

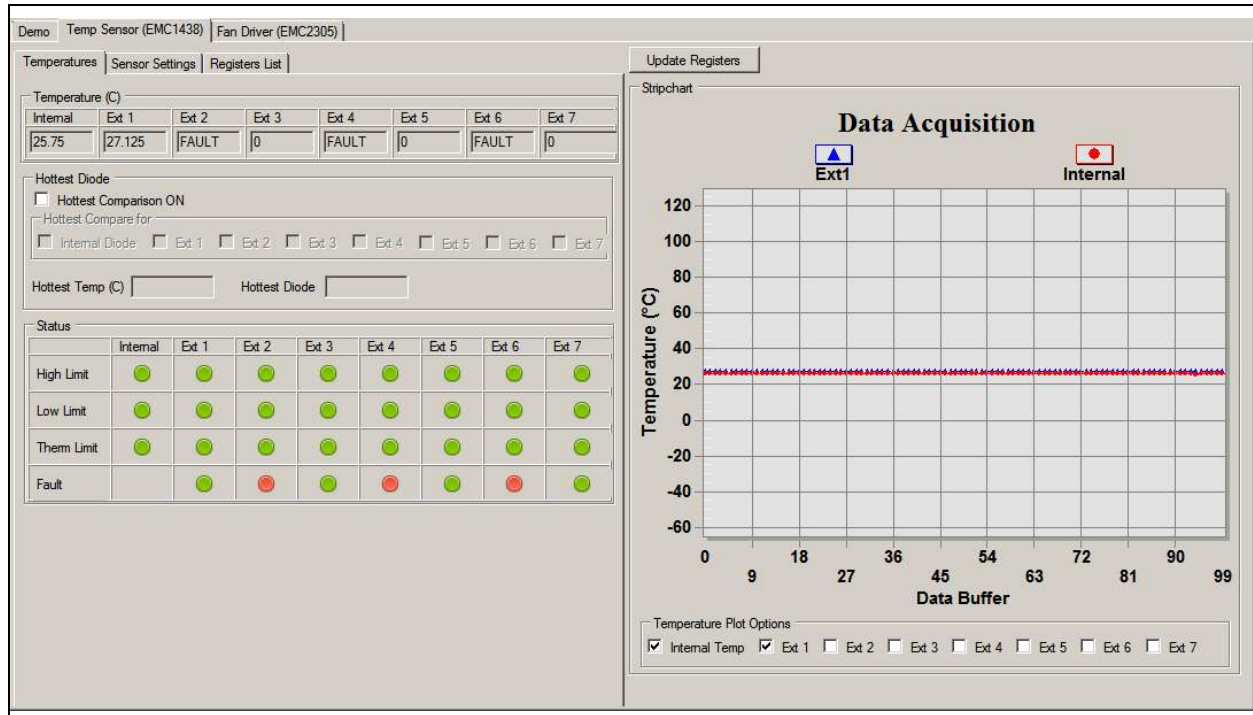

The Temperatures tab of the Temperature Sensor View provides an overview of all the temperature related readings from the EMC1438 device:

- The temperature values are presented in both the Temperature table and in the Data Acquisition chart. The chart can be configured to display any combination of the device channels by enabling the corresponding channel check box from the Temperature Plot Options section.
- The Hottest Diode section allows turning the hottest diode detection ON or OFF and provides information about the hottest temperature and the diode it was detected on.
- The device's status is displayed in the Status section, where a green icon represents normal operation (limit not exceed, no fault condition) and a red icon signals that a limit has been reached or a fault condition has been detected.
- The device data can be read continuously, by clicking the **Start** button from the toolbar or manually sampled by clicking the **Update Registers** button. The chart is only updated during continuous sampling.

The Sensor Settings tab provides access to all of the device's settings, limit configuration and alert options.

FIGURE 3-13: SENSOR SETTINGS TAB

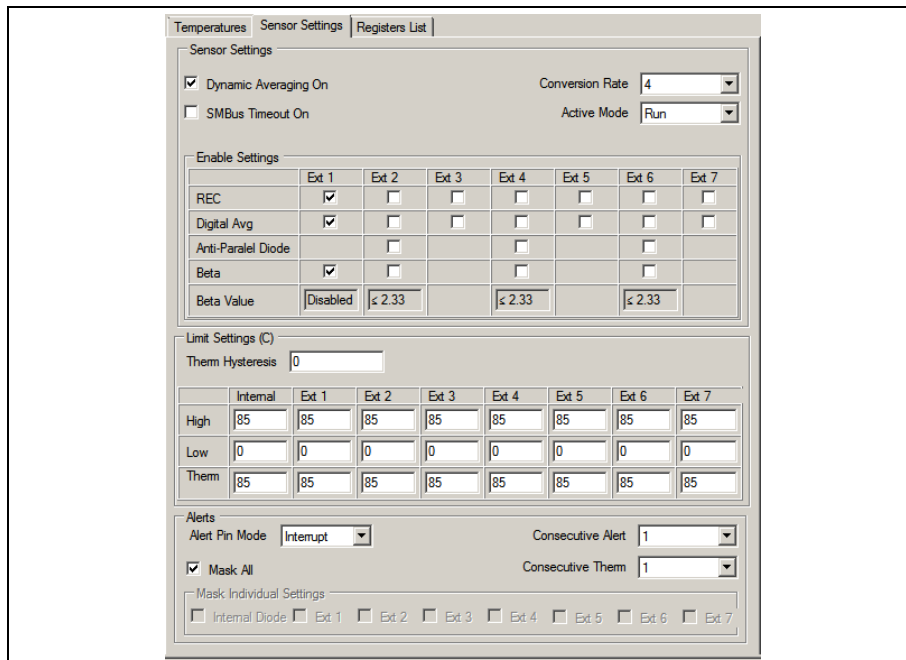

The Register List tab gives an overview of all the device registers, their addresses and their values. The values are updated continuously after the **Start** button is clicked or updated after clicking the **Update Registers** button from the EMC1438 tab. Each register can also be individually read by selecting the register and right-clicking, then selecting Read.

FIGURE 3-14: REGISTERS LIST TAB

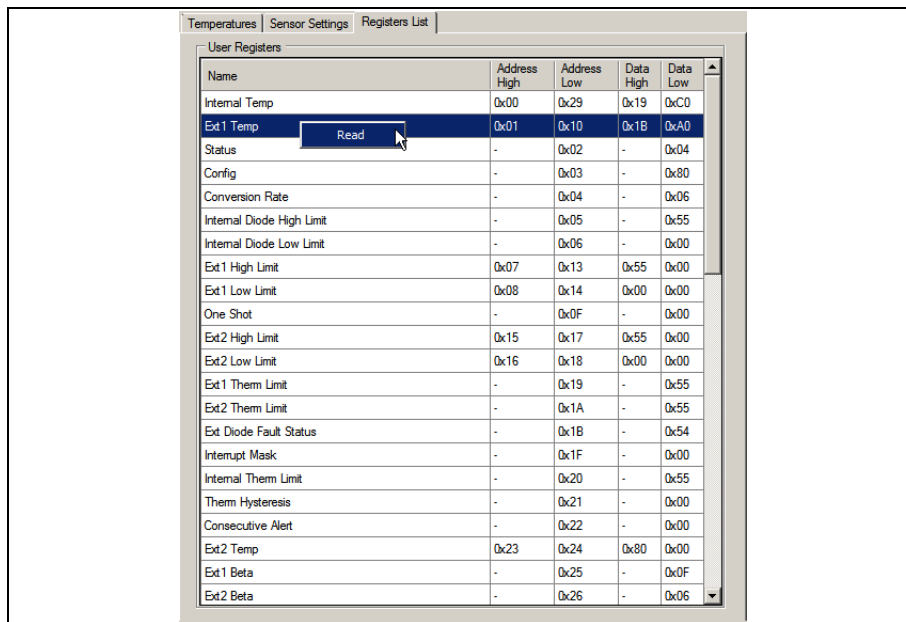

3.4.3 Fan Driver Tab

The Fan Driver tab (Figure 3-15) provides easy access to the EMC2305 device's settings and readings.

Each section of the Fan Driver tab is highlighted in Figure 3-15 by a red rectangle and a number, with each corresponding number being described below.

FIGURE 3-15: FAN DRIVER TAB

The screenshot shows the Fan Driver tab for the EMC2305 device. It is divided into several sections, each highlighted with a red box and a circled number:

- 1. Results:** A table showing tachometer readings for five fans (FAN 1 to FAN 5), all showing a value of 8190.
- 2. General Settings:** A section with checkboxes for "Mask All Alerts", "SMBus Timeout", and "Enable". Under "Enable", there are checkboxes for "Fan 1 Interrupt" through "Fan 5 Interrupt".
- 3. Status:** A table with columns "Fan Stall", "Fan Spin", and "Drive Fail" for FAN 1 through FAN 5. All cells contain a green circle icon.
- 4. PWM Settings:** A section for "Fans Configuration" (FAN 1 selected). It includes fields for "PWM Polarity" (Normal), "PWM Output" (Open Drain), "PWM Drive Setting" (29.8039%), "Frequency" (Base: 26.00 kHz, Final: 26 kHz), and "PWM Divide" (1).
- 5. General Configuration:** A section with two configurations. Configuration 1 includes "RPM-based Fan Speed Control Alg" (checked), "Reported Min RPM" (1000), "TACH Count Multiplier" (2), "No Fan Poles" (2 poles), "Min TACH Edges" (5), and "Update Time" (100 ms). Configuration 2 includes "Ramp Rate" (unchecked), "Glitch Filter" (checked), "Derivative Options" (Basic Derivative), and "Error Range" (0 RPM). There is also a "Spin Up Configuration" section with "100% Duty Cycle" (checked), "Number of Updates" (Disabled), "Drive Level" (30%), "Spin up Time" (250 ms), and a "Gain" section with "Derivative Factor", "Integral Factor", and "Proportional Factor" all set to 4x.
- 6. Fan Related Settings:** A section with fields for "Min Drive" (16.0784%), "Valid Tach Count" (1728), "Min RPM" (4551.1111), "Drive Fail Band" (0), "Max Step" (16), "Max RPM" (7900), "Tach Target" (1573), "RPM value" (0), and "Target RPM" (4999.5677).

1. The Fan Tachometer Results section shows the last read values of the tachometer for all fan driver channels.
2. The General Settings section allows toggling the alert settings and the SMBus timeout.
3. The Status table displays the status of the fan driver: a green icon indicates normal operation and a red icon indicates a flagged fan event.
4. The PWM Settings section contains all PWM related settings for the selected fan driver channel.
5. The General Configuration section gives access to the rest of the driver's settings.
6. The Fan Related Settings section contains the drive and RPM/Tach options needed to properly drive the connected fan. The Min RPM field is connected to the Valid Tach Count field; if either value is changed, the other is updated as well. The same is true for the Target RPM field and the Tach Target field. The RPM value represents the read RPM value of the fan.

Chapter 4. Hardware Description

4.1 ADM00879 DEMONSTRATION BOARD DESCRIPTION

The printed circuit board form factor is compatible with a PCI (Peripheral Component Interconnect) card slot in a desktop PC. With the addition of a PCI bracket and an IDE (Integrated Drive Electronics) connector (J7 - not populated), the board can be mounted inside a desktop PC case. The J10 connector footprint is compatible with an on-board USB connector.

Power for this board can come from four sources. The 2.1 mm jack (J8) is used to power the board during normal operation with 12V, while the micro USB connector (J9) is used for powering the low-voltage digital circuits, in case the 12V supply is missing. There are also two test points (TP1 and TP2) available that are connected in parallel with the jack, for a direct connection to a lab power supply. The IDE connector J7 (not populated) can also be used to draw 12V to the board.

The maximum voltage supported on the jack and the power test point connections is 16V, limited by the 3.3V regulator that is powering the low voltage circuits.

The communication with the PC is provided through the MCP2221 device, an USB to I²C bridge.

There are five fan channels available, each with its own switch mode PWM driver and 6 remote diode channels accessible through J1, J2 and J3 connector blocks. All five fan driver channels are symmetrical and share the same designators on the silkscreen.

FIGURE 4-1: ADM00879 DEMONSTRATION BOARD TOP VIEW

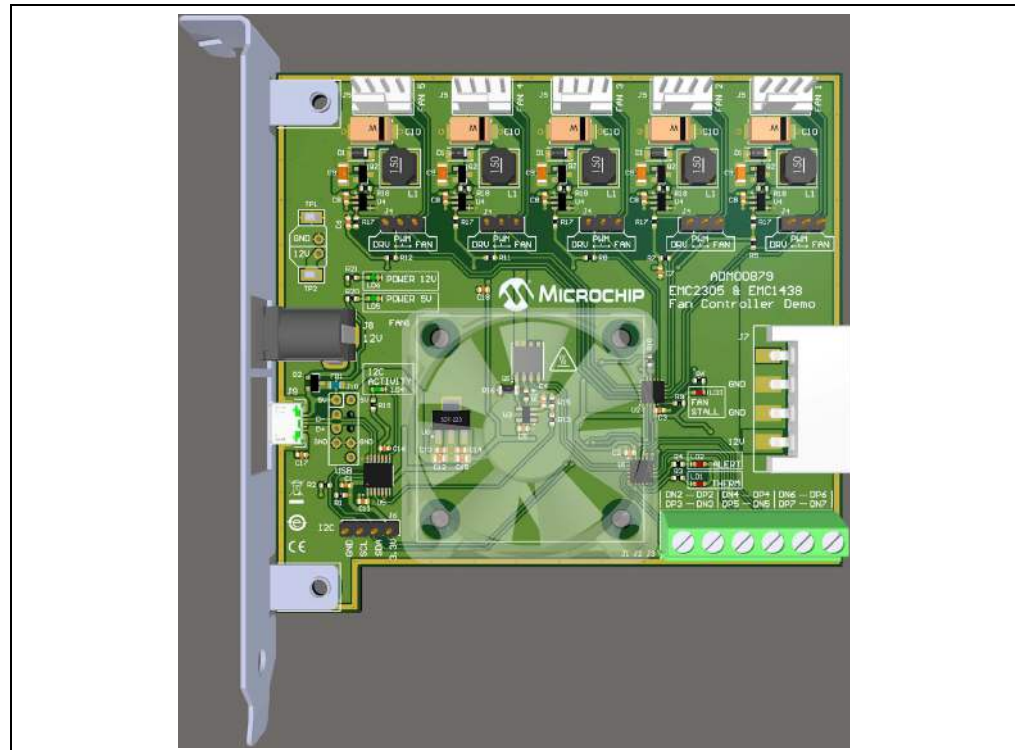

4.1.1 Fan Connection Options

The fan connectors are compatible with both 3-wire and 4-wire fans. Below each fan driver is a 3-pin jumper that connects the PWM output from the EMC2305 fan controller to the fan driver circuit (DRV) or the PWM input of the 4-wire fan (FAN).

If no jumper selection is made, the fan driver provides an unregulated 12V output.

4.1.2 PWM Fan Driver

All five fan driver channels use an efficient high side DC/DC drive topology that maintains the GND connection for the fan tachometer output.

FIGURE 4-2: PWM FAN DRIVER

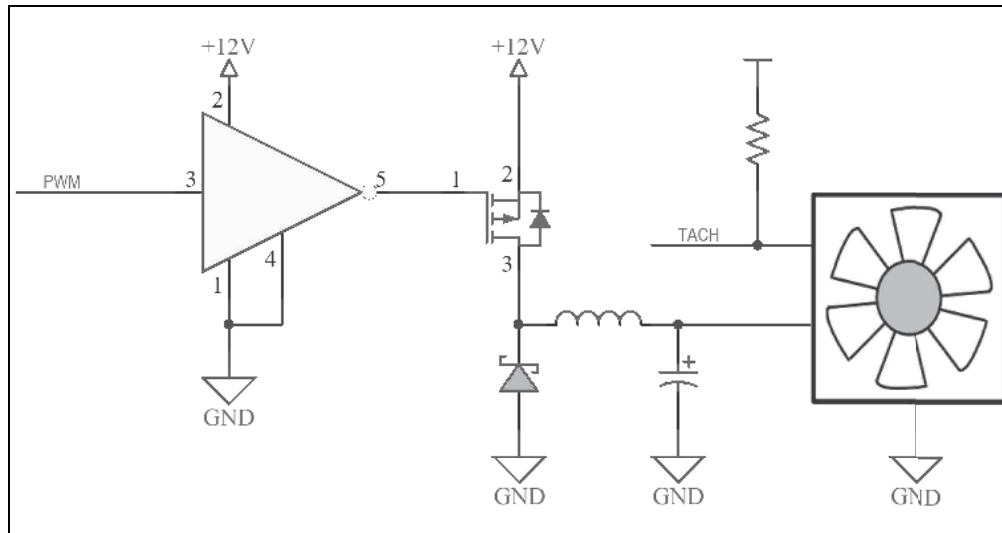

The output voltage versus the PWM duty cycle for the fan provided in the kit is characterized in [Figure 4-3](#).

FIGURE 4-3: PWM DUTY CYCLE TO VOLTAGE CORRESPONDENCE

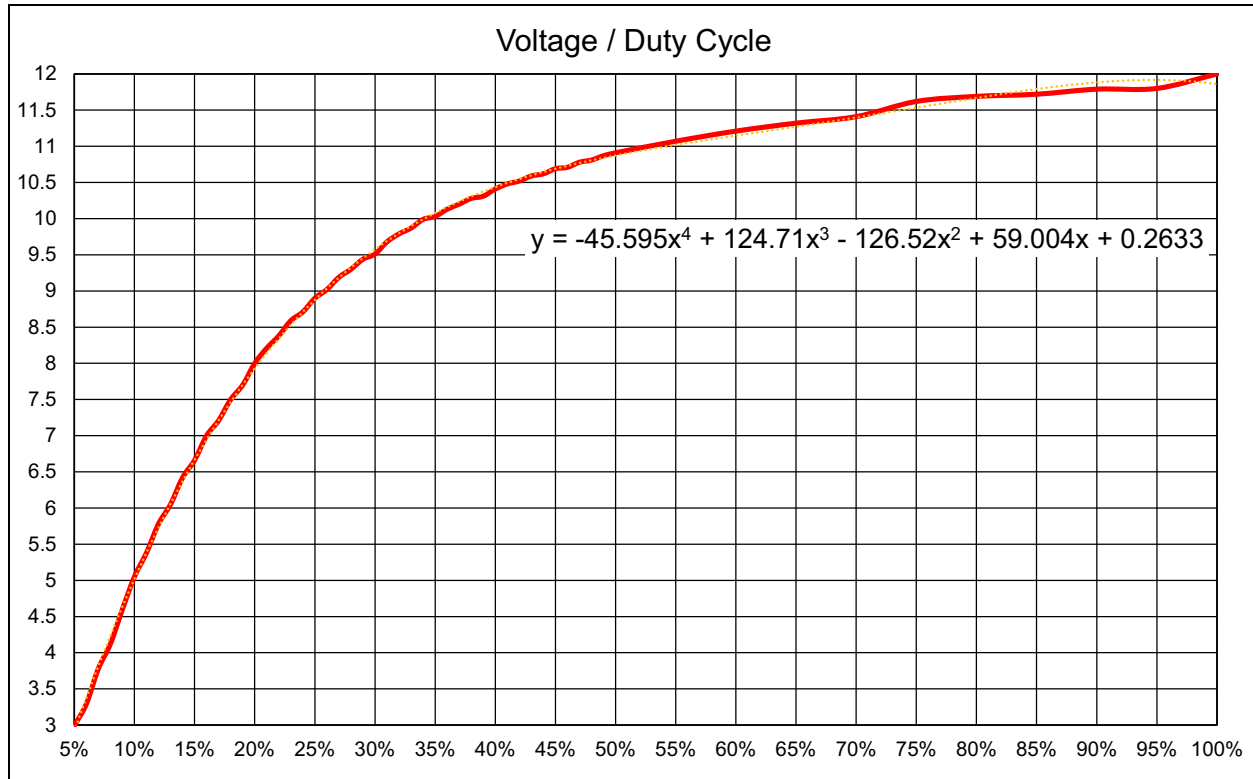

Considering that the minimum specified voltage for the provided fan is 7V, the minimum drive setting needs to be set at 16%, in order to ensure a reliable fan operation and tachometer reading.

This minimum drive setting and Voltage per Duty cycle behavior is dependent on the drawn current and varies from fan to fan. [Figure 4-3](#) is provided only for reference on how this particular driver and fan combination behaves and to help with understanding the relationship between the output voltage and the PWM duty cycle.

It can be noticed that, by setting the PWM duty cycle at 50%, the fan RPM won't be set at 50%. This is where the EMC2305 RPM-based Fan Speed Control Algorithm solves the problem, by automatically adjusting the PWM duty cycle to achieve a target RPM.

4.1.3 On-Board Temperature Channels

Two out of the 8 temperature channels of the EMC1438 device are connected on fixed sensors on the ADM00879 Demonstration Board:

1. The internal temperature channel inside the EMC1438 (U1)
2. The demonstration heat source and remote diode transistor Q1.

4.1.4 On-Board Demonstration Heat Source and Remote Diode

The Q1 dual NPN transistor is used both as a heat source and as a remote diode, in order to help provide an out-of-the-box demonstration of the implemented PID (proportional-integral-derivative) controller in the Thermal Management Utility GUI.

FIGURE 4-4: HEAT SOURCE SCHEMATIC

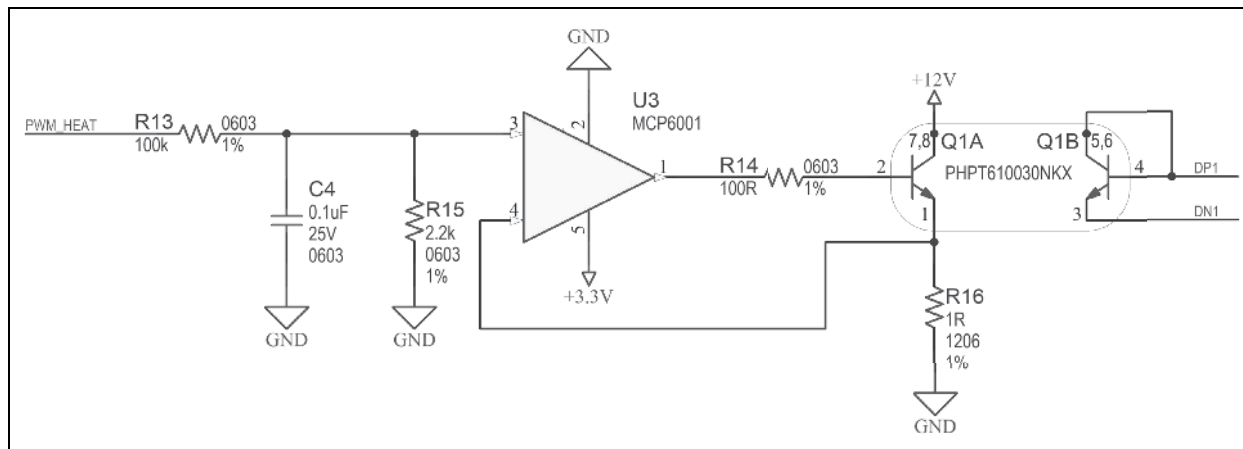

4.1.5 External Temperature Remote Diode Connections

There are 6 remote-temperature channels accessible through three terminal blocks, each connector being able to support two anti-parallel diodes.

FIGURE 4-5: REMOTE DIODE CONNECTION DIAGRAM

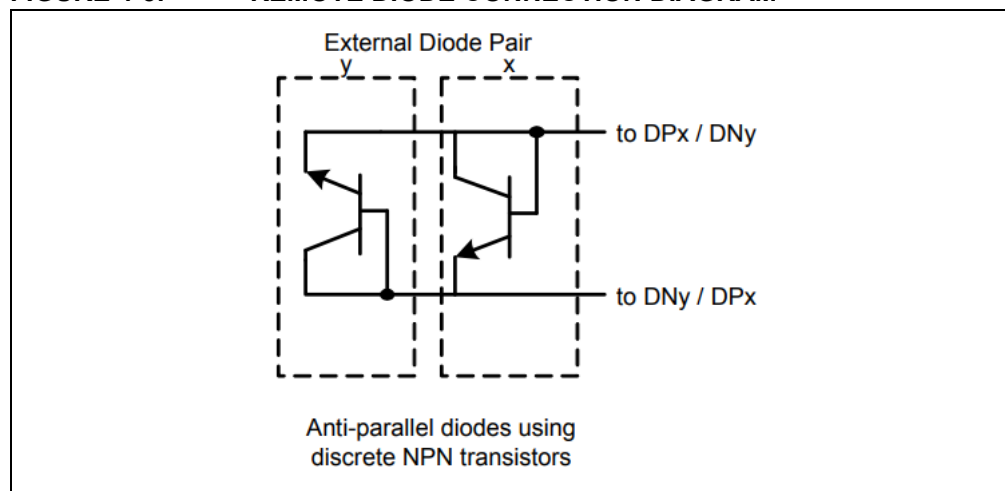

4.1.6 Optional Desktop PC Integration

The board has the necessary form factor to fit into a PCI slot inside a desktop PC. The mounting bracket and PC connectors are not included but are listed in the bill of materials (BOM) for reference.

Appendix A. Schematics and Layouts

A.1 INTRODUCTION

This appendix contains the following schematics and layouts for ADM00879 Demonstration Board:

- Board – Schematic – EMC2305 and EMC1438
- Board – Schematic – Fan Driver (Fan 1)
- Board – Schematic – Fan Driver (Fan 2)
- Board – Schematic – Fan Driver (Fan 3)
- Board – Schematic – Fan Driver (Fan 4)
- Board – Schematic – Fan Driver (Fan 5)
- Board – Schematic – Interface and Power
- Board – Schematic – Mechanical
- Board – Top Silk
- Board – Top Copper and Silk
- Board – Top Copper
- Board – Bottom Copper
- Board – Bottom Copper and Silk
- Board – Bottom Silk

A.2 BOARD – SCHEMATIC – EMC2305 AND EMC1438

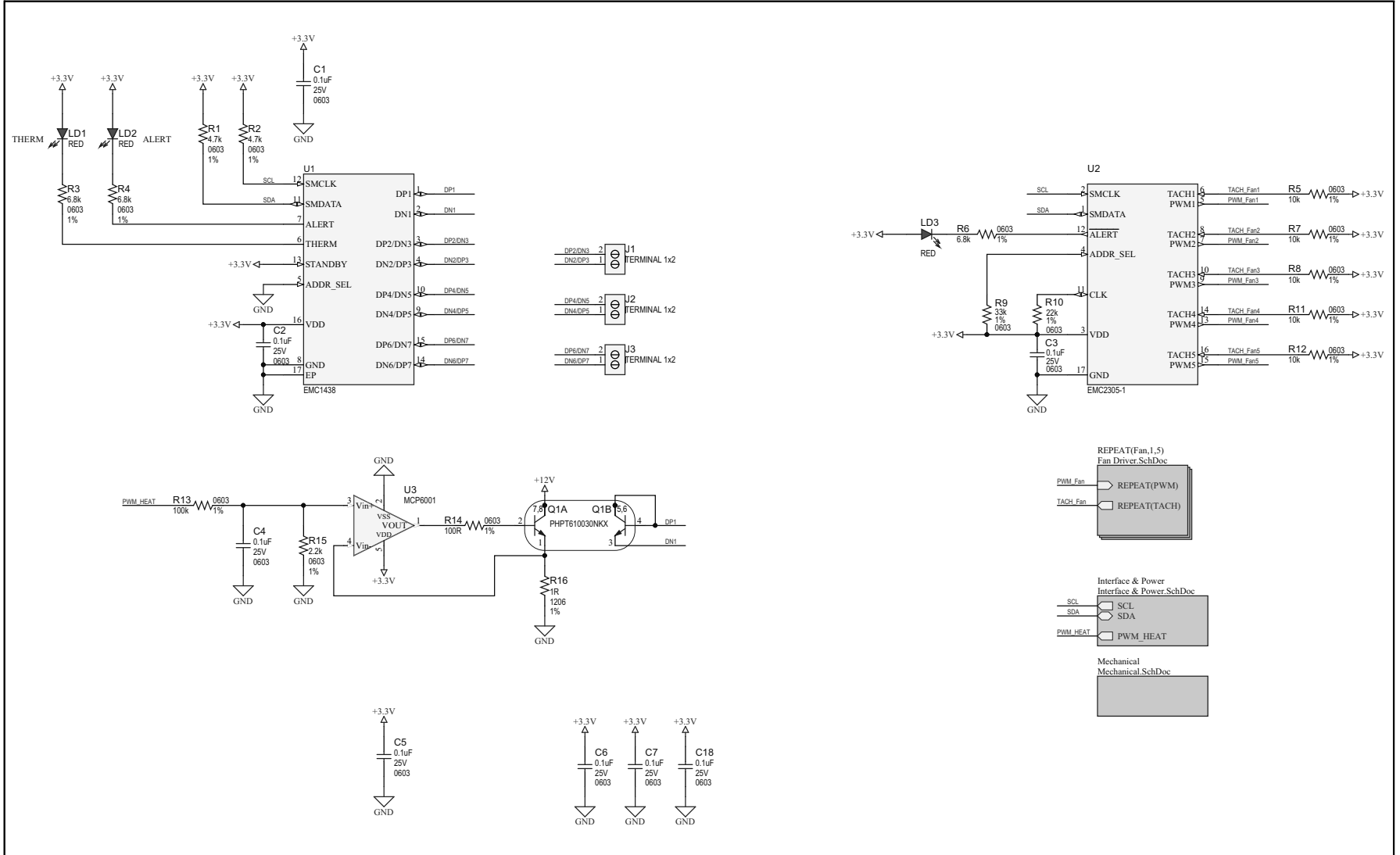

A.3 BOARD – SCHEMATIC – FAN DRIVER (FAN 1)

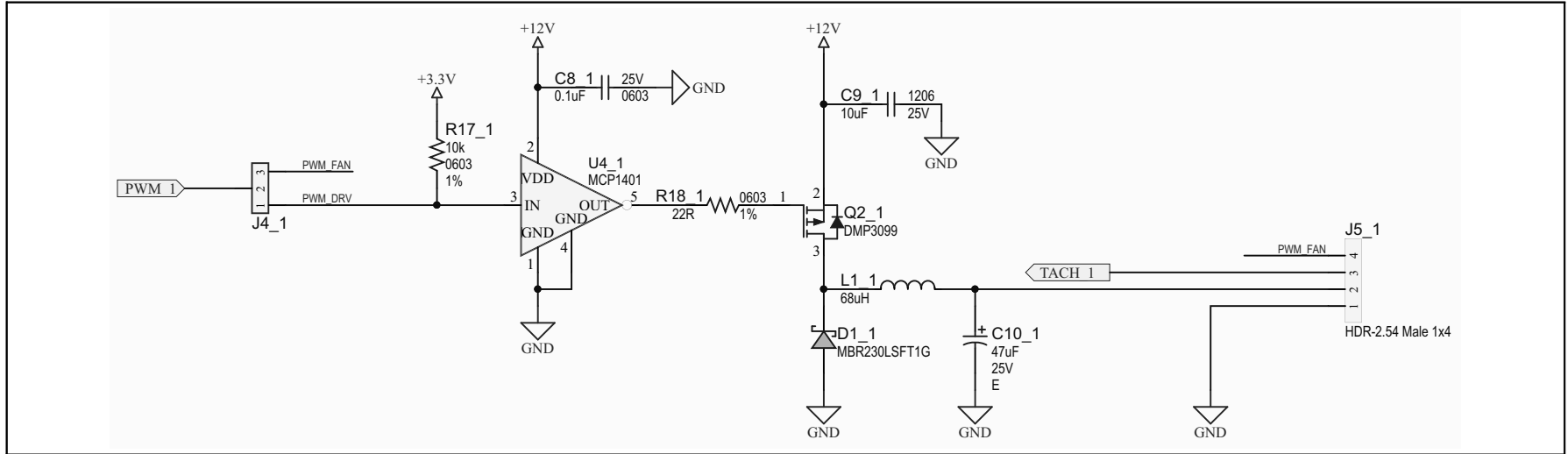

A.4 BOARD – SCHEMATIC – FAN DRIVER (FAN 2)

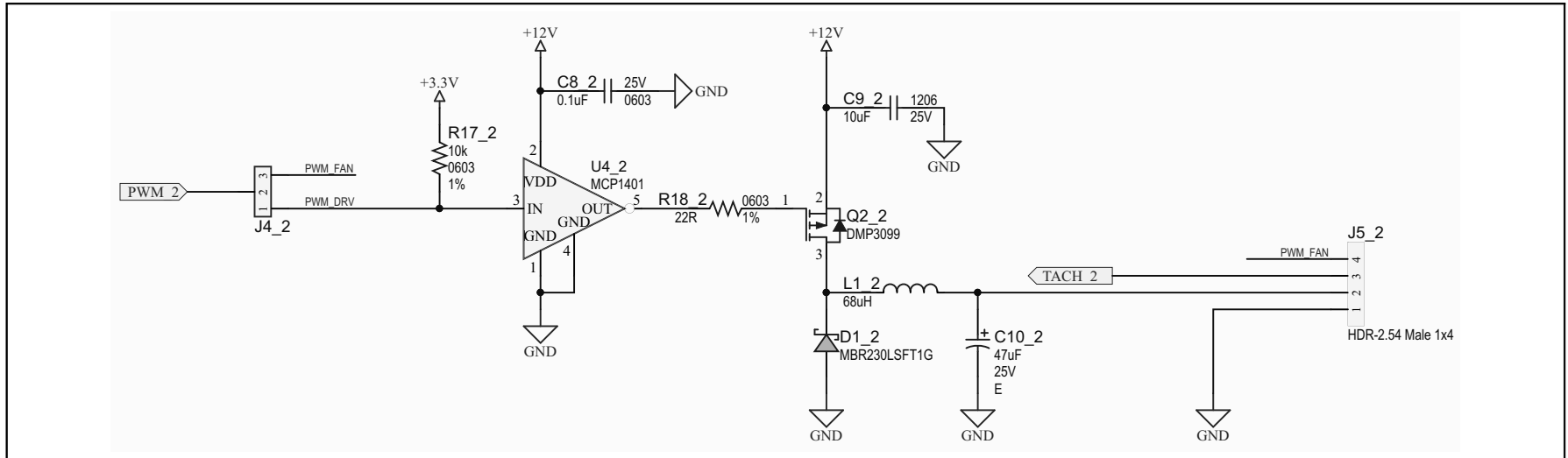

A.5 BOARD – SCHEMATIC – FAN DRIVER (FAN 3)

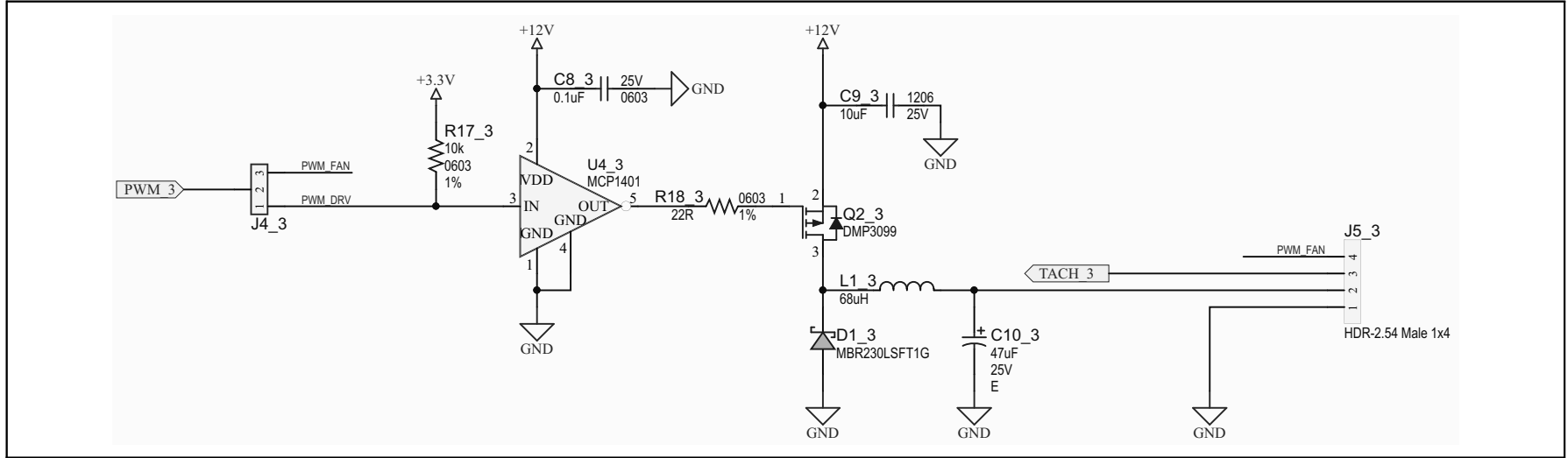

A.6 BOARD – SCHEMATIC – FAN DRIVER (FAN 4)

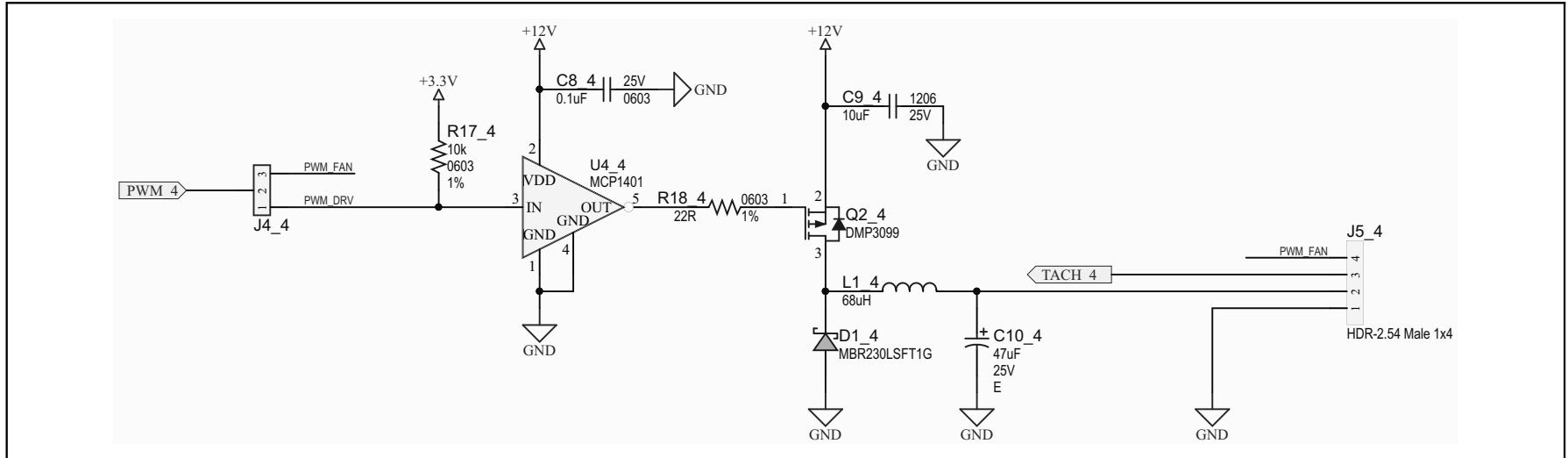

A.7 BOARD – SCHEMATIC – FAN DRIVER (FAN 5)

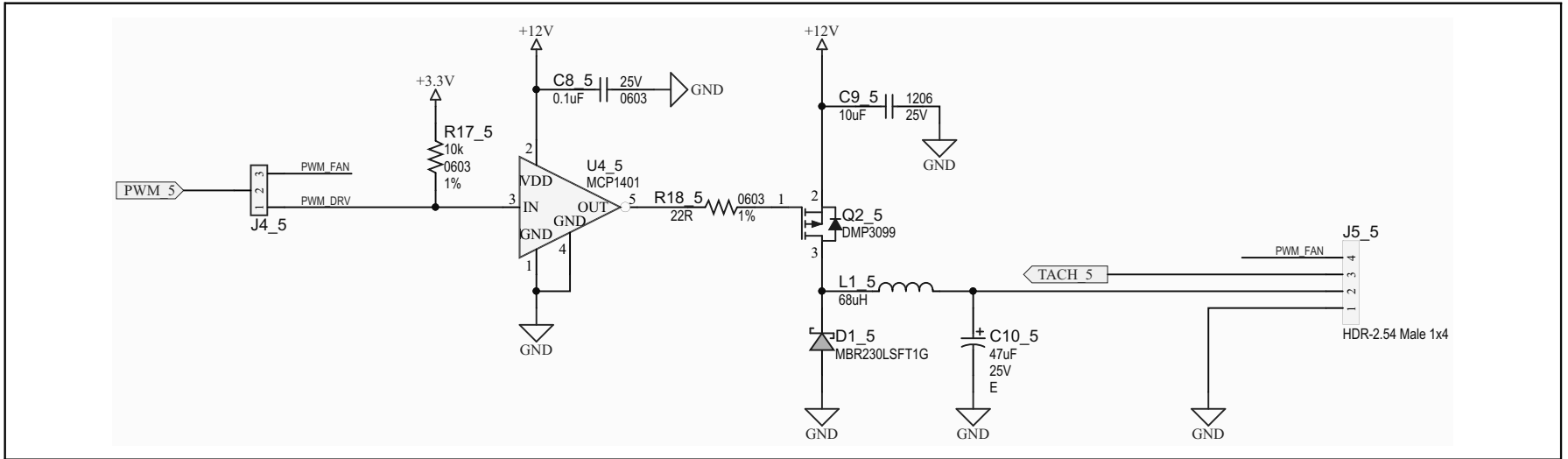

A.8 BOARD – SCHEMATIC – INTERFACE AND POWER

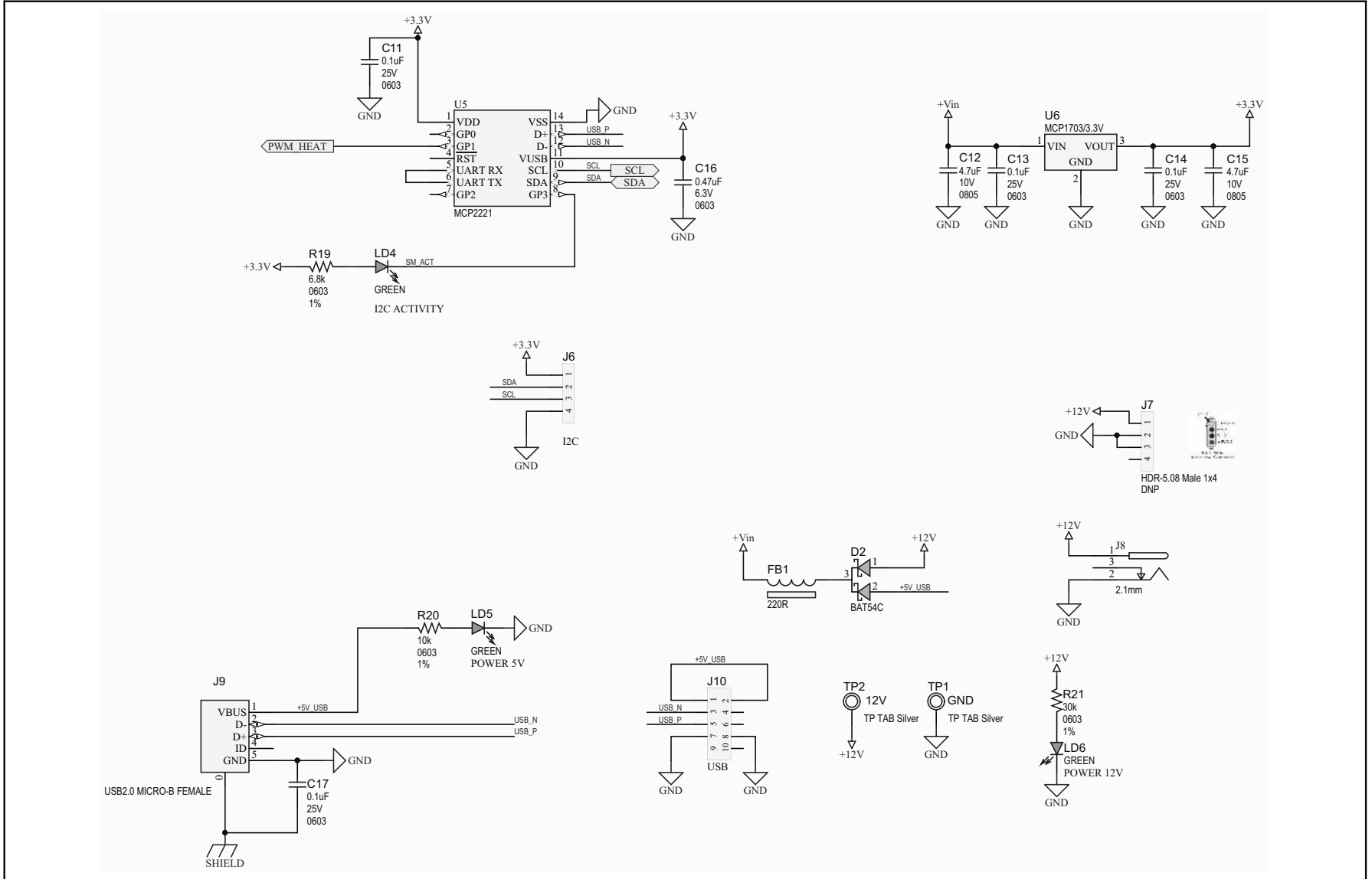

A.9 BOARD – SCHEMATIC – MECHANICAL

FAN1

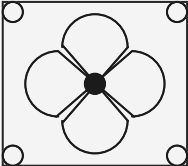

FAN 40x10mm 3 Wire

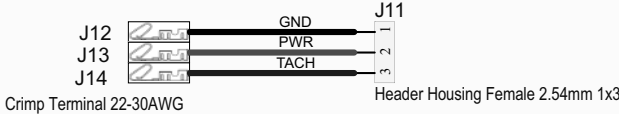

J12
J13
J14

GND
PWR
TACH

J11

Crimp Terminal 22-30AWG

Header Housing Female 2.54mm 1x3

PAD1
RUBBER PAD D9.4 H4.8

PAD2
RUBBER PAD D9.4 H4.8

PAD3
RUBBER PAD D9.4 H4.8

PAD4
RUBBER PAD D9.4 H4.8

SCR1
Screw M3x16mm Nylon

SCR2
Screw M3x16mm Nylon

SCR3
Screw M3x16mm Nylon

SCR4
Screw M3x16mm Nylon

STANDOFF1
Standoff M3 Nylon 10mm

STANDOFF2
Standoff M3 Nylon 10mm

STANDOFF3
Standoff M3 Nylon 10mm

STANDOFF4
Standoff M3 Nylon 10mm

NUT1
Nut M3 Nylon

NUT2
Nut M3 Nylon

NUT3
Nut M3 Nylon

NUT4
Nut M3 Nylon

CBL1



USB Male-A to Male Micro-B

JP1 **JP2** **JP3** **JP4** **JP5**

Shunt 2.54mm 1x2 Handle

BRACKET1



PCI Bracket DNP

SCR5
DNP
Phillips Screw 1/4"

SCR6
DNP

LABEL1

Need Help?
MICROCHIP <http://support.microchip.com>
Assy# Serial#
Label Need Help Large

Example of remote diodes using NPN transistors

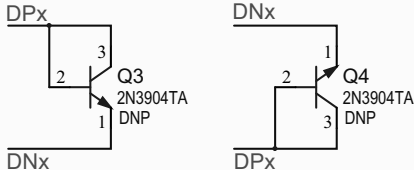

DPx

DNx

Q3
2N3904TA
DNP

Q4
2N3904TA
DNP

A.10 BOARD – TOP SILK

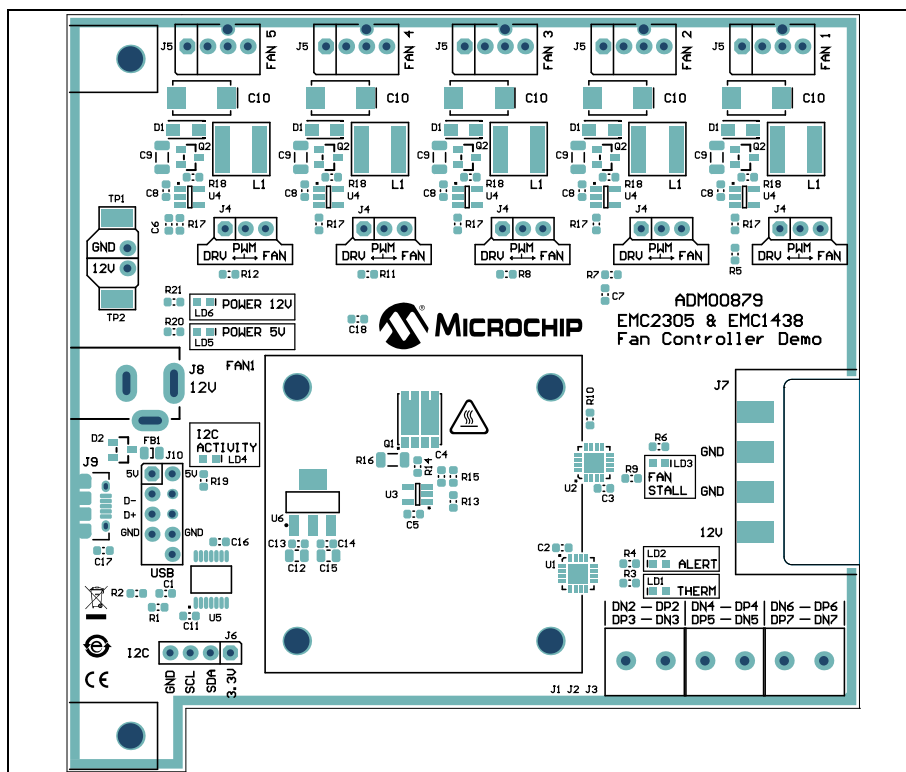

A.11 BOARD – TOP COPPER AND SILK

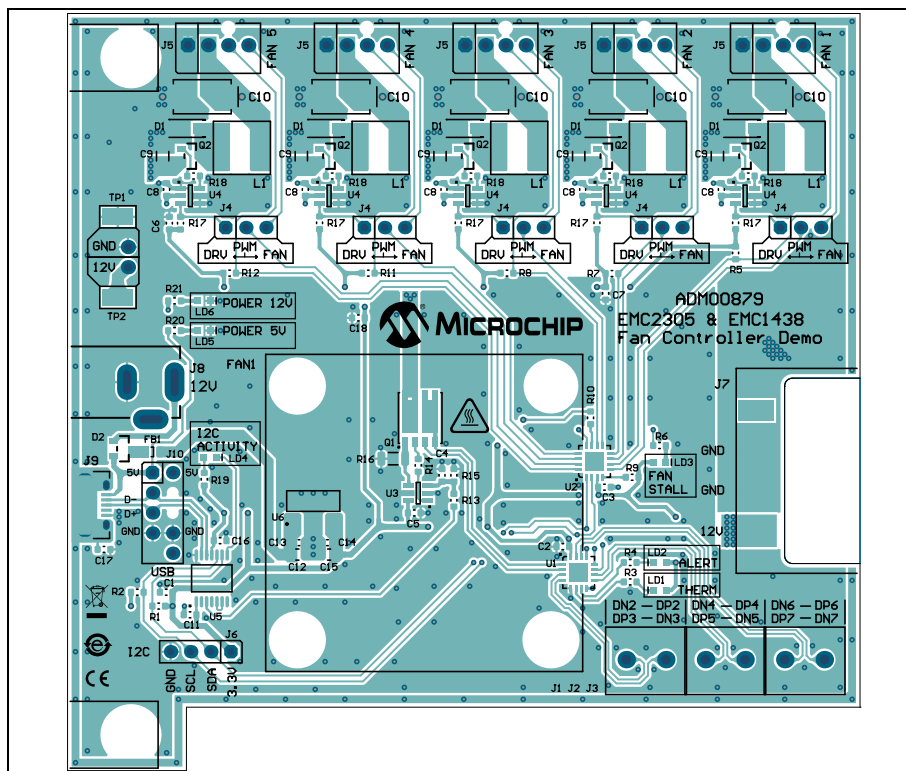

A.12 BOARD – TOP COPPER

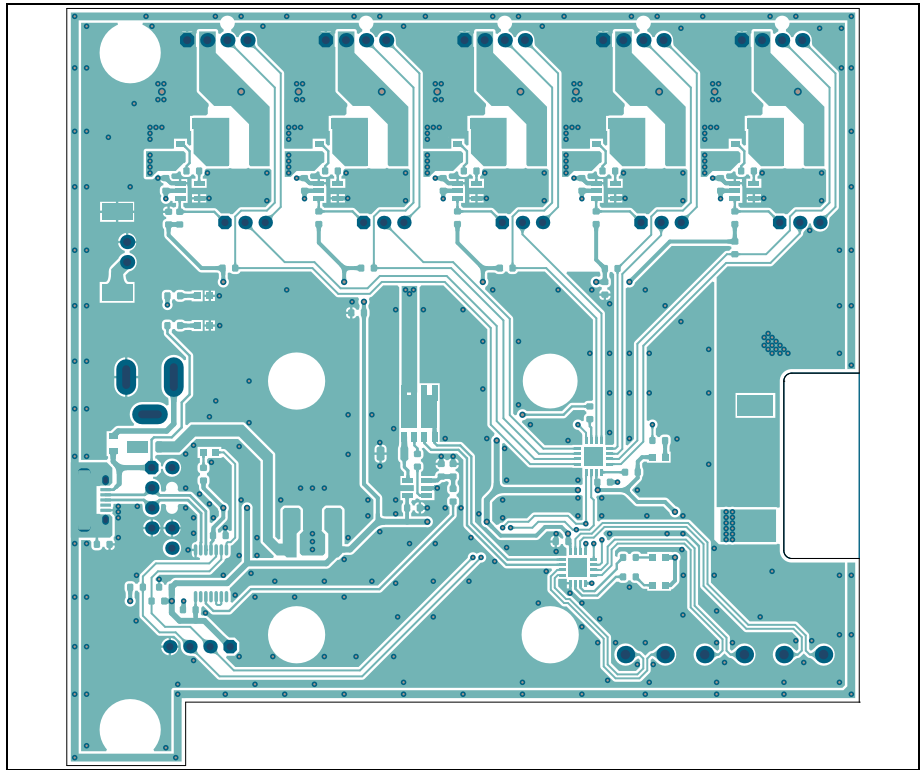

A.13 BOARD – BOTTOM COPPER

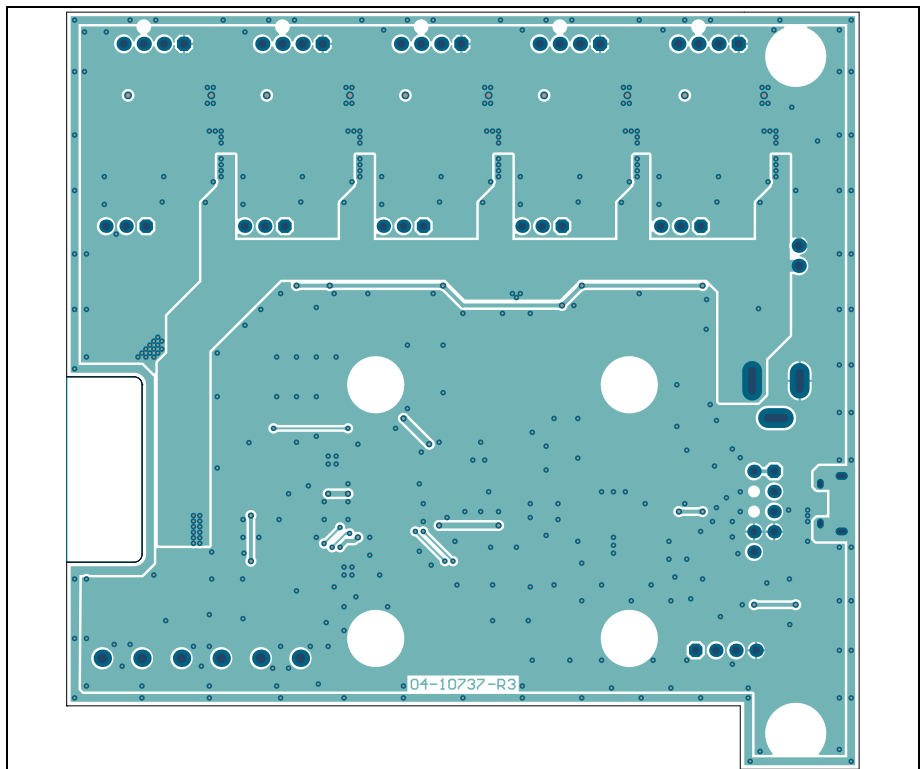

A.14 BOARD – BOTTOM COPPER AND SILK

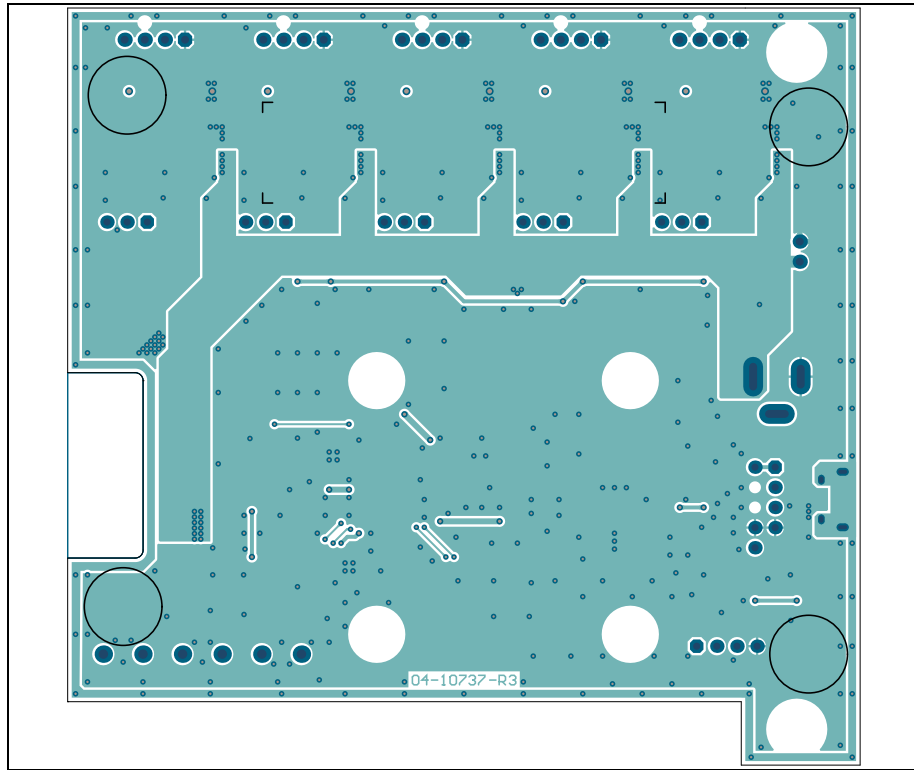

A.15 BOARD – BOTTOM SILK

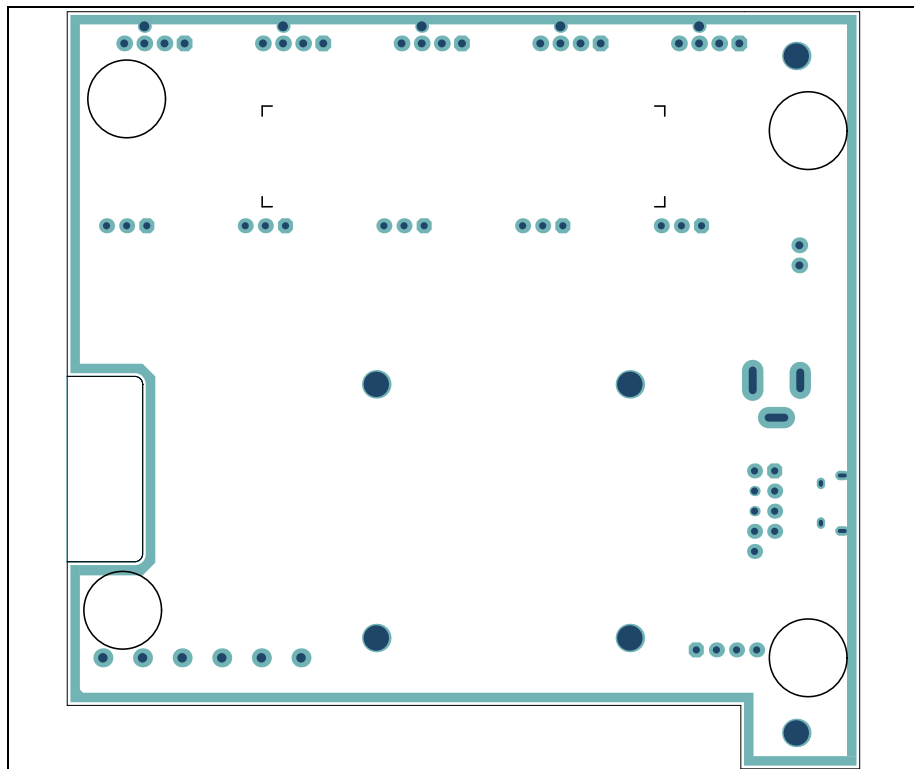

Appendix B. Bill of Materials (BOM)

TABLE B-1: ADM00879 DEMONSTRATION BOARD BILL OF MATERIALS

Qty.	Reference	Description	Manufacturer	Part Number
17	C1, C2, C3, C4, C5, C6, C7, C8_Fan1, C8_Fan2, C8_Fan3, C8_Fan4, C8_Fan5, C11, C13, C14, C17, C18	Capacitor, Ceramic, 0.1 μ F, 25V, 10%, X7R, SMD, 0603	TDK Corporation	C1608X7R1E104K080AA
5	C10_Fan1, C10_Fan2, C10_Fan3, C10_Fan4, C10_Fan5	Capacitor, Tantalum, 47 μ F, 25V, 10%, 0.6R, SMD, E	Vishay Sprague	293D476X9025E2TE3
2	C12, C15	Capacitor, Ceramic, 4.7 μ F, 10V, 10%, X5R, SMD, 0805	Panasonic® - ECG	ECJ-GVB1A475M
1	C16	Capacitor, Ceramic, 0.47 μ F, 6.3V, 10%, X5R, SMD, 0603	Murata Electronics North America, Inc.	GRM188R60J474KA01D
5	C9_Fan1, C9_Fan2, C9_Fan3, C9_Fan4, C9_Fan5	Capacitor, Ceramic, 10 μ F, 25V, 10%, X7R, SMD, 1206	Taiyo Yuden Co., Ltd.	TMK316B7106KL-TD
5	D1_Fan1, D1_Fan2, D1_Fan3, D1_Fan4, D1_Fan5	Diode, Schottky, 430 mV, 2A, 30V, SMD, SOD-123FL	ON Semiconductor®	MBR230LSFT1G
1	D2	Diode, Schottky, 530 mV, 200 mA, 30V, SOT-23-3	Diodes Incorporated®	BAT54CTA
1	FB1	Ferrite, 2A, 220R SMD, 0805	Murata Electronics North America, Inc.	BLM21PG221SN1D
3	J1, J2, J3	Connector Terminal, 5 mm, 1x2, Female, 12-26AWG, 18A, TH, R/A	PHOENIX CONTACT	1935161
5	J4_Fan1, J4_Fan2, J4_Fan3, J4_Fan4, J4_Fan5	Connector, HDR-2.54, Male, 1x3, Gold, 5.84 MH, TH, VERT	FCI	68000-103HLF
5	J5_Fan1, J5_Fan2, J5_Fan3, J5_Fan4, J5_Fan5	Connector, HDR-2.54, Male, 1x4, Tin, Lock, 7.49 MH, TH, VERT	Molex® Connector Corporation	0470531000
1	J6	Connector, HDR-2.54, Male, 1x4, Gold, 5.84 MH, TH, VERT	Würth Elektronik	61300411121
1	J8	Connector, Power, 2.1 mm, 5.5 mm, Switch, Slotted, TH, R/A	MPD – Memory Protection Devices, Inc.	EJ508A
1	J9	Connector, USB 2.0 MICRO-B, Female, TH/SMD, R/A	FCI	10118194-0001LF

Note 1: The components listed in this Bill of Materials are representative of the PCB assembly. The released BOM used in manufacturing uses all RoHS-compliant components.

ADM00879 Demonstration Board User's Guide

TABLE B-1: ADM00879 DEMONSTRATION BOARD BILL OF MATERIALS (CONTINUED)

Qty.	Reference	Description	Manufacturer	Part Number
5	L1_Fan1, L1_Fan2, L1_Fan3, L1_Fan4, L1_Fan5	Inductor, 68 μ H, 0.95A, 20%, SMD, L6W6H4.5	Taiyo Yuden Co., Ltd.	NRS6045T680MMGK
3	LD1, LD2, LD3	Diode, LED, Red, 2V, 20 mA, 250 mcd, Clear, SMD, 0603	Würth Elektronik	150060RS75000
3	LD4, LD5, LD6	Diode, LED, Green, 3.2V, 20 mA, 430 mcd, Clear, SMD, 0603	Würth Elektronik	150060GS75000
1	PCB1	ADM00879 Demonstration Board - Printed Circuit Board	Microchip Technology Inc.	04-10737-R3
1	Q1	Transistor, BJT, Dual, NPN+NPN, 100V, 3A, 1.25W, LFPAK56D-8	Nexperia USA Inc.	PHPT610030NKX
5	Q2_Fan1, Q2_Fan2, Q2_Fan3, Q2_Fan4, Q2_Fan5	Transistor, FET, P-CH, -30V, -3.8A, 1.08W, SOT-23-3	Diodes Incorporated®	DMP3099L-7
2	R1, R2	Resistor, TKF, 4.7 k Ω , 1%, 1/10W, SMD, 0603	Panasonic® - ECG	ERJ-3EKF4701V
1	R10	Resistor, TKF, 22 k Ω , 1%, 1/10W, SMD, 0603	Panasonic® - ECG	ERJ-3EKF2202V
1	R13	Resistor, TKF, 100 k Ω , 1%, 1/10W, SMD, 0603	Panasonic® - ECG	ERJ-3EKF1003V
1	R14	Resistor, TKF, 100R, 1%, 1/10W, SMD, 0603	Panasonic® - ECG	ERJ-3EKF1000V
1	R15	Resistor, TKF, 2.2k Ω , 1%, 1/10W, SMD, 0603	Panasonic® - ECG	ERJ-3EKF2201V
1	R16	Resistor, TKF, 1R, 1%, 1/4W, SMD, 1206	Yageo Corporation	RC1206FR-071RL
5	R18_Fan1, R18_Fan2, R18_Fan3, R18_Fan4, R18_Fan5	Resistor, TKF, 22R, 1%, 1/10W, SMD, 0603	Panasonic® - ECG	ERJ-3EKF22R0V
1	R21	Resistor, TKF, 30 k Ω , 1%, 1/10W, SMD, 0603	Stackpole Electronics, Inc.	RMCF0603FT30K0
4	R3, R4, R6, R19	Resistor, TKF, 6.8 k Ω , 1%, 1/10W, SMD, 0603	Panasonic® - ECG	ERJ-3EKF6801V
11	R5, R7, R8, R11, R12, R17_Fan1, R17_Fan2, R17_Fan3, R17_Fan4, R17_Fan5, R20	Resistor, TKF, 10 k Ω , 1%, 1/10W, SMD, 0603	Panasonic® - ECG	ERJ-3EKF1002V
1	R9	Resistor, TKF, 33 k Ω , 1%, 1/10W, SMD, 0603	Panasonic® - ECG	ERJ-3EKF3302V
4	STANDOFF1, STAND- OFF2, STANDOFF3, STANDOFF4	Mechanical, HW, Stand-off, M3x10 mm, M/F, HEX, Nylon	Essentra Components	NTS-10
2	TP1, TP2	Connector, TP, TAB, Silver, Mini, 3.8 x 2.03, SMD	Keystone Electronics Corp.	5019

Note 1: The components listed in this Bill of Materials are representative of the PCB assembly. The released BOM used in manufacturing uses all RoHS-compliant components.

TABLE B-1: ADM00879 DEMONSTRATION BOARD BILL OF MATERIALS (CONTINUED)

Qty.	Reference	Description	Manufacturer	Part Number
1	U1	MCHP Analog Temperature Sensor, -40°C to +125°C, EMC1438-2-AP-TR, QFN-16	Microchip Technology inc.	EMC1438-2-AP-TR
1	U2	MCHP Analog Fan Controller, 5-Channel EMC2305-1-AP-TR, QFN-16	Microchip Technology Inc.	EMC2305-1-AP-TR
1	U3	MCHP Analog OPAMP 1-Channel, 1 MHz MCP6001T-I/OT, SOT-23-5	Microchip Technology Inc.	MCP6001T-I/OT
5	U4_Fan1, U4_Fan2, U4_Fan3, U4_Fan4, U4_Fan5	MCHP Analog Fet Driver, Single-Inverting, MCP1401T-E/OT, SOT-23-5	Microchip Technology Inc.	MCP1401T-E/OT
1	U5	MCHP Interface USB I ² C UART MCP2221-I/ST, TSSOP-14	Microchip Technology Inc.	MCP2221-I/ST
1	U6	MCHP Analog LDO, 3.3V, MCP1703T-3302E/DB, SOT-223-3	Microchip Technology Inc.	MCP1703T-3302E/DB

Note 1: The components listed in this Bill of Materials are representative of the PCB assembly. The released BOM used in manufacturing uses all RoHS-compliant components.

TABLE B-2: BILL OF MATERIALS – MECHANICAL PARTS

Qty.	Reference	Description	Manufacturer	Part Number
1	CBL1	Mechanical, HW, Cable, USB Male-A to Male Micro-B, Clear 4	DongGuan ZanXin	A006ZX021
1	FAN1	Mechanical, HW, Fan, 12VDC, 40 x 10 mm, 8000 RPM, Tachometer 3, Wire	Delta Electronics, Inc.	ASB0412VHA-AF00
1	J11	Mechanical, HW, Connector Header Housing, Female, 2.54 mm 1x3	Molex [®] Connector Corporation	22-01-3037
3	J12, J13, J14	Mechanical, HW, CRIMP, Terminal, Female, 22-30AWG, Tin	Molex [®] Connector Corporation	0008500113
5	JP1, JP2, JP3, JP4, JP5	Mechanical, HW, Jumper, 2.54 mm, 1x2, Handle, Gold	TE Connectivity, Ltd.	881545-2
1	LABEL1	LABEL	—	—
4	NUT1, NUT2, NUT3, NUT4	Mechanical, HW, NUT, M3, Nylon	Keystone Electronics Corp.	4688
4	PAD1, PAD2, PAD3, PAD4	Mechanical, HW, Rubber Pad, Cylindrical, D9.4, H4.8, Clear	Multicomp Inc.	2565
2	Q3, Q4	Transistor, BJT, NPN, 40V, 0.2A, 0.625W, TO-92-3	Fairchild Semiconductor [®]	2N3904TA
4	SCR1, SCR2, SCR3, SCR4	Mechanical, HW, Screw, M3 x 16 mm, Pan, Slotted, Nylon	Keystone Electronics Corp.	29346

Note 1: The components listed in this Bill of Materials are representative of the PCB assembly. The released BOM used in manufacturing uses all RoHS-compliant components.

ADM00879 Demonstration Board User's Guide

TABLE B-3: BILL OF MATERIALS – DO NOT POPULATE PARTS

Qty.	Reference	Description	Manufacturer	Part Number
1	BRACKET1	Mechanical, HW, Bracket, PCI	Keystone Electronics Corp.	9203-1
1	J7	Connector, HDR-5.08, Male, 1x4, Tin, 7.49 MH, SMD	Molex Connector Corporation	0015244455
1	J10	Connector, HDR-2.54, Male, 2x5 0.100" (2.54 mm), TH, VERT	Samtec, Inc.	TSW-105-07-G-D
2	SCR5, SCR6	Machine Screw Pan, Phillips, 4-40	Keystone Electronics Corp.	9900

Note 1: The components listed in this Bill of Materials are representative of the PCB assembly. The released BOM used in manufacturing uses all RoHS-compliant components.



MICROCHIP

Worldwide Sales and Service

AMERICAS

Corporate Office
2355 West Chandler Blvd.
Chandler, AZ 85224-6199
Tel: 480-792-7200
Fax: 480-792-7277
Technical Support:
<http://www.microchip.com/support>
Web Address:
www.microchip.com

Atlanta

Duluth, GA
Tel: 678-957-9614
Fax: 678-957-1455

Austin, TX

Tel: 512-257-3370

Boston

Westborough, MA
Tel: 774-760-0087
Fax: 774-760-0088

Chicago

Itasca, IL
Tel: 630-285-0071
Fax: 630-285-0075

Dallas

Addison, TX
Tel: 972-818-7423
Fax: 972-818-2924

Detroit

Novi, MI
Tel: 248-848-4000

Houston, TX

Tel: 281-894-5983

Indianapolis

Noblesville, IN
Tel: 317-773-8323
Fax: 317-773-5453
Tel: 317-536-2380

Los Angeles

Mission Viejo, CA
Tel: 949-462-9523
Fax: 949-462-9608
Tel: 951-273-7800

Raleigh, NC

Tel: 919-844-7510

New York, NY

Tel: 631-435-6000

San Jose, CA

Tel: 408-735-9110
Tel: 408-436-4270

Canada - Toronto

Tel: 905-695-1980
Fax: 905-695-2078

ASIA/PACIFIC

Australia - Sydney
Tel: 61-2-9868-6733

China - Beijing
Tel: 86-10-8569-7000

China - Chengdu
Tel: 86-28-8665-5511

China - Chongqing
Tel: 86-23-8980-9588

China - Dongguan
Tel: 86-769-8702-9880

China - Guangzhou
Tel: 86-20-8755-8029

China - Hangzhou
Tel: 86-571-8792-8115

China - Hong Kong SAR
Tel: 852-2943-5100

China - Nanjing
Tel: 86-25-8473-2460

China - Qingdao
Tel: 86-532-8502-7355

China - Shanghai
Tel: 86-21-3326-8000

China - Shenyang
Tel: 86-24-2334-2829

China - Shenzhen
Tel: 86-755-8864-2200

China - Suzhou
Tel: 86-186-6233-1526

China - Wuhan
Tel: 86-27-5980-5300

China - Xian
Tel: 86-29-8833-7252

China - Xiamen
Tel: 86-592-2388138

China - Zhuhai
Tel: 86-756-3210040

ASIA/PACIFIC

India - Bangalore
Tel: 91-80-3090-4444

India - New Delhi
Tel: 91-11-4160-8631

India - Pune
Tel: 91-20-4121-0141

Japan - Osaka
Tel: 81-6-6152-7160

Japan - Tokyo
Tel: 81-3-6880-3770

Korea - Daegu
Tel: 82-53-744-4301

Korea - Seoul
Tel: 82-2-554-7200

Malaysia - Kuala Lumpur
Tel: 60-3-7651-7906

Malaysia - Penang
Tel: 60-4-227-8870

Philippines - Manila
Tel: 63-2-634-9065

Singapore
Tel: 65-6334-8870

Taiwan - Hsin Chu
Tel: 886-3-577-8366

Taiwan - Kaohsiung
Tel: 886-7-213-7830

Taiwan - Taipei
Tel: 886-2-2508-8600

Thailand - Bangkok
Tel: 66-2-694-1351

Vietnam - Ho Chi Minh
Tel: 84-28-5448-2100

EUROPE

Austria - Wels
Tel: 43-7242-2244-39
Fax: 43-7242-2244-393

Denmark - Copenhagen
Tel: 45-4450-2828
Fax: 45-4485-2829

Finland - Espoo
Tel: 358-9-4520-820

France - Paris
Tel: 33-1-69-53-63-20
Fax: 33-1-69-30-90-79

Germany - Garching
Tel: 49-8931-9700

Germany - Haan
Tel: 49-2129-3766400

Germany - Heilbronn
Tel: 49-7131-67-3636

Germany - Karlsruhe
Tel: 49-721-625370

Germany - Munich
Tel: 49-89-627-144-0
Fax: 49-89-627-144-44

Germany - Rosenheim
Tel: 49-8031-354-560

Israel - Ra'anana
Tel: 972-9-744-7705

Italy - Milan
Tel: 39-0331-742611
Fax: 39-0331-466781

Italy - Padova
Tel: 39-049-7625286

Netherlands - Drunen
Tel: 31-416-690399
Fax: 31-416-690340

Norway - Trondheim
Tel: 47-7289-7561

Poland - Warsaw
Tel: 48-22-3325737

Romania - Bucharest
Tel: 40-21-407-87-50

Spain - Madrid
Tel: 34-91-708-08-90
Fax: 34-91-708-08-91

Sweden - Gothenberg
Tel: 46-31-704-60-40

Sweden - Stockholm
Tel: 46-8-5090-4654

UK - Wokingham
Tel: 44-118-921-5800
Fax: 44-118-921-5820