

ALD500/ALD523D Chipset

A/D Converter-Display Module Controller

The ALD500/523D chipset is a precision 18-bit plus sign bit dual-slope integrating analog/digital converter. Designed as an analog/digital 2-chip chipset to minimize mixed signal crosstalk and noise, this A/D converter and display module controller combination is unique to the industry. The ALD500 analog chip or optional ALD500R functions as the dual-slope integrator — the latter incorporates an on-chip precision voltage reference. The digital chip, ALD523D is a dedicated controller I.C. designed to conveniently interface with a variety of LCD/VFD multiline alphanumeric character display modules. The ALD523D features multi-function control inputs for a broad range of user selectable functions, including up to 3 separate display settings. The ALD523D also features power-down (sleep mode), chip select and integration time select. Combined, the chipset offers designers an immediate solution to an otherwise complex engineering task that would generally require extensive development effort using discrete components.

The chipset is primarily intended for precision embedded display applications including embedded digital panel meters, customized/specialized instrument displays, temperature monitoring, high resolution voltmeters, signal conditioners, laboratory datalogging, process monitors, and DVM for portable/field troubleshooting and calibration systems. Full-scale analog input range is +/- 2.00000 VDC with a linearity of 0.005%. Up to 7 full digits can be displayed as an A/D converter measurement value.

Configured for maximum user flexibility, the ALD523D controller chip can be operated in 3 user selectable application specific functional modes; Mode A - calibrated reference, Mode B - ratiometric, and Mode C - display only. Mode A is used primarily for measurements against a calibrated reference voltage typically required in precision voltmeter applications. Mode B is intended for measurements against a ratiometric reference voltage such as those required in weigh scale applications. Mode C is used for display applications where the input data is already formatted in industry standard serial binary from other microprocessors or data converters - up to 32 serial bits including a sign bit. In Mode C, only the digital ALD523D chip is required.

In addition to the three modes of operation, up to three separate display group settings are available, each with different scale factors and UNIT displays. For applications such as embedded measurement instrument modules, up to three separate ranges of a single measurement can be preset, selected and displayed. Both software and hardware based settings are available for setting a variety of parameters such as Samples Averaging, Decimal Placement, Digits Blanking, Zero Level, Display Group Setting, Mode Selection, UNIT Labeling, and Calibration.



Chipset consisting of ALD500 Integrating Analog Processor and ALD523D Display Module Controller

Features

- Up to 7 full digits plus sign (± 9999999) display
- Stand alone display module control operation.
- Up to 3 separate DISPLAY settings.
- Compatible with industry standard 1-line or 2-line x 16 character display module such as LCD or VFD
- +/-3V to +/-5V power supply.
- Accepts most industry standard serial inputs up to 32-bits, including sign bit.
- 3 selectable operating modes.
- PC based software included for calibration and initial setup.

Software

Standard PC setup/calibration software is provided for use with the chipset. This software is used to initially configure the ALD523D controller chip in any of the 3 operating modes, as well as to perform system calibration and to establish user-defined alphanumeric "TITLE and UNIT fields" for the display module, which are stored in an external EEPROM. Communications between the ALD523D and PC are performed over the parallel printer port.

Product Applications

- Embedded precision digital display
- High-resolution DC voltmeter
- High accuracy and low noise weigh scale system
- Precision PH measurement system
- Stand-alone display interface controller
- External serial data display module
- Hi-res A/D converter with alphanumeric display interface
- Temperature monitoring system

ALD523D Specifications*

- Power Supply
Voltage: 3-5 Vdc (5.5 Vdc max)
Current: 6 mA typical
- Input
Low: -0.3 - 1.0 V
High: 3.5 - 5.3 V
- Output
Low: 0.1 - 0.5 V
High: 3.6 - 4.8 V
- Oscillator
Crystal Freq: 3.6864 MHz typical
Ext Freq: 15 MHz max

ALD523D Packaging

- ALD523DPH 28-Pin plastic (PDIP)
- ALD523DSH 28-Pin small outline (SOIC)

ALD523D Operating Temp. Range

- 0 degree to 70 degrees C
(Optional industrial grade also available)

Ordering Information *

Evaluation and Board Level Product

| Part No. | Description |
|----------|-----------------------|
| MB203PDK | PDIP Design Kit |
| MB203SDK | SOIC Design Kit |
| MB203PCB | Printed Circuit Board |

Chipset I.C. Product (recommended)

| Part No. | Operating Mode |
|----------------|----------------|
| ALD500AUPC | Mode A, B |
| ALD500RAU-10PE | Mode A |
| ALD523DPH | Mode A, B & C |

* For special requirements such as different package type, grade selection, please refer to individual data sheet or contact factory.

Advanced Linear Devices, Inc. develops and manufactures a full line of precision CMOS linear integrated circuits, including analog switches, A/D converters, voltage comparators, operational amplifiers, conventional and EPAD[®] MOSFET transistors.

Most standard devices are available as ASIC cells for the development of semi-custom integrated circuits.

ALD also serves customers through expertise in full custom design engineering, including device and process development.

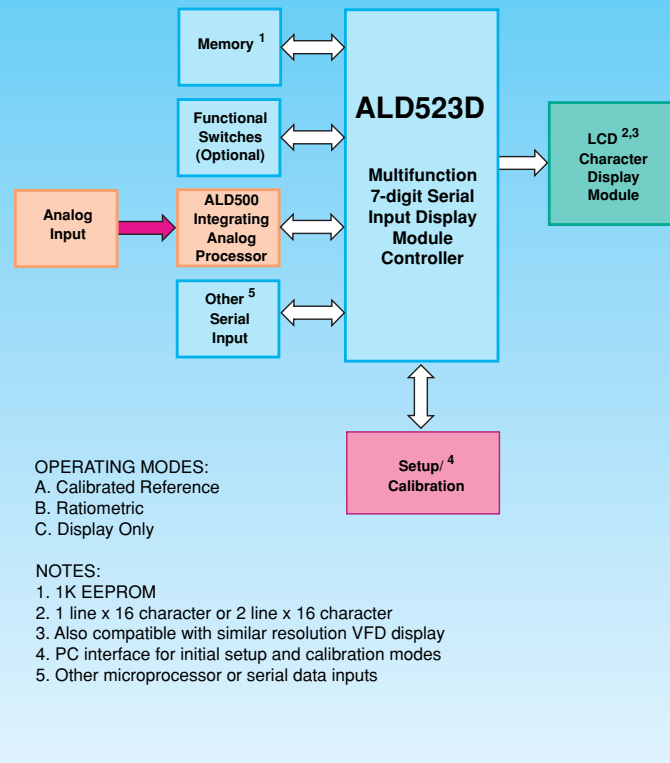

Chipset Functional Block Diagram