

P.C.B. HOLE DRILLINGS
(P.C.B. TOP SIDE)

(5:1)

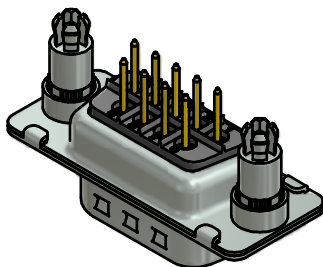
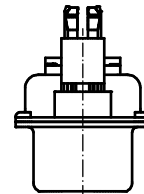
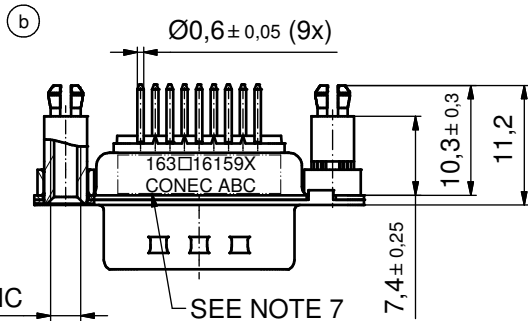
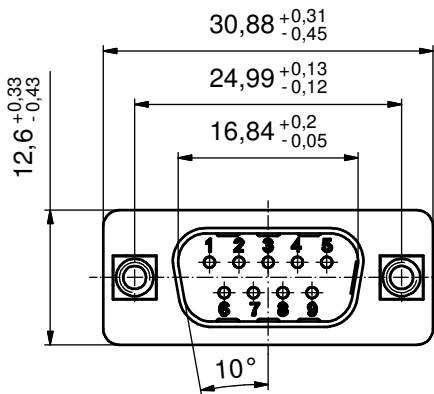
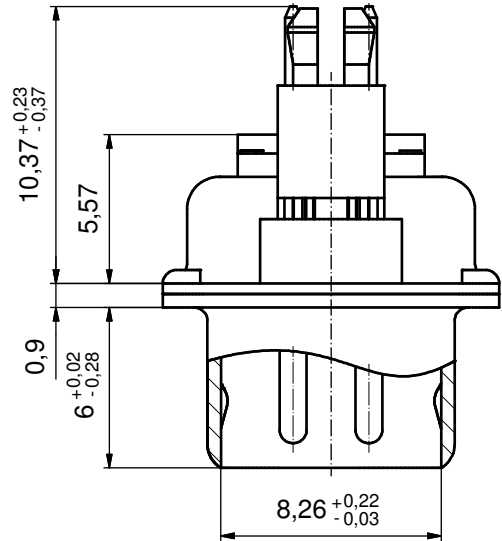

NOTES:

1. METALSHELLS: STEEL; min. 315µm TIN over 40-80µm NICKEL
2. INSULATORS: PBT GF UL 94 V-0, BLACK
3. CONTACTS: COPPER ALLOY; PLATING (SEE PART NO.):
 - PLEASE ADD A for GOLD FLASH over NICKEL (PREFERRED TYPE)
 - PLEASE ADD B for 20µm HARD GOLD over min. 50µm NICKEL
 - PLEASE ADD C for 30µm HARD GOLD over min. 50µm NICKEL
 - PLEASE ADD J for 50µm HARD GOLD over min. 50µm NICKEL
4. THREADED SPACER CLIPS:
 - COPPER ALLOY; min. 200µm TIN over 80µm NICKEL
 - PCB-HOLE: $\phi 3.1 \pm 0,1$; PCB THICKNESS 1,6mm
5. COLLARS: COPPER ALLOY; min. 200µm TIN over 80µm NICKEL
6. MAXIMUM TORQUE VALUE FOR THREAD: 6 in.LB
7. CONNECTOR IS PART MARKED: 163□16159X CONEC ABC (see note 3)

Directive 2002/95/EC RoHS compliant

THIS DRAWING MAY NOT BE COPIED OR REPRODUCED IN ANY WAY, AND MAY NOT BE PASSED ON TO A THIRD PARTY WITHOUT WRITTEN PERMISSION. OWNERSHIP AND COPYRIGHT OF CONEC GmbH DO NOT ALTER CAD DRAWING BY HAND				tolerance		scale: 2:1 (5:1)
				date	name	material: see notes
				drawn	08.01.13	Henneboel
				appd.	09.01.13	Fischer
				norm		
				d-old	16K1A1045/16K1A1201/16K1A681	
				4 x b	A4593	08.01.2013
			a	Original		
			rev.	description	date	name
						title: D-SUB MALE 9pos. SOLDER PIN STRAIGHT with threaded spacer clip
						dwg no: 16K1A3163 (b)
						DIN-A3 sh: 1
						part no: (b)163□16159X (see note 3)