

PRE-FEED 1 1/8" STROKE
POST-FEED 1 5/8" STROKE

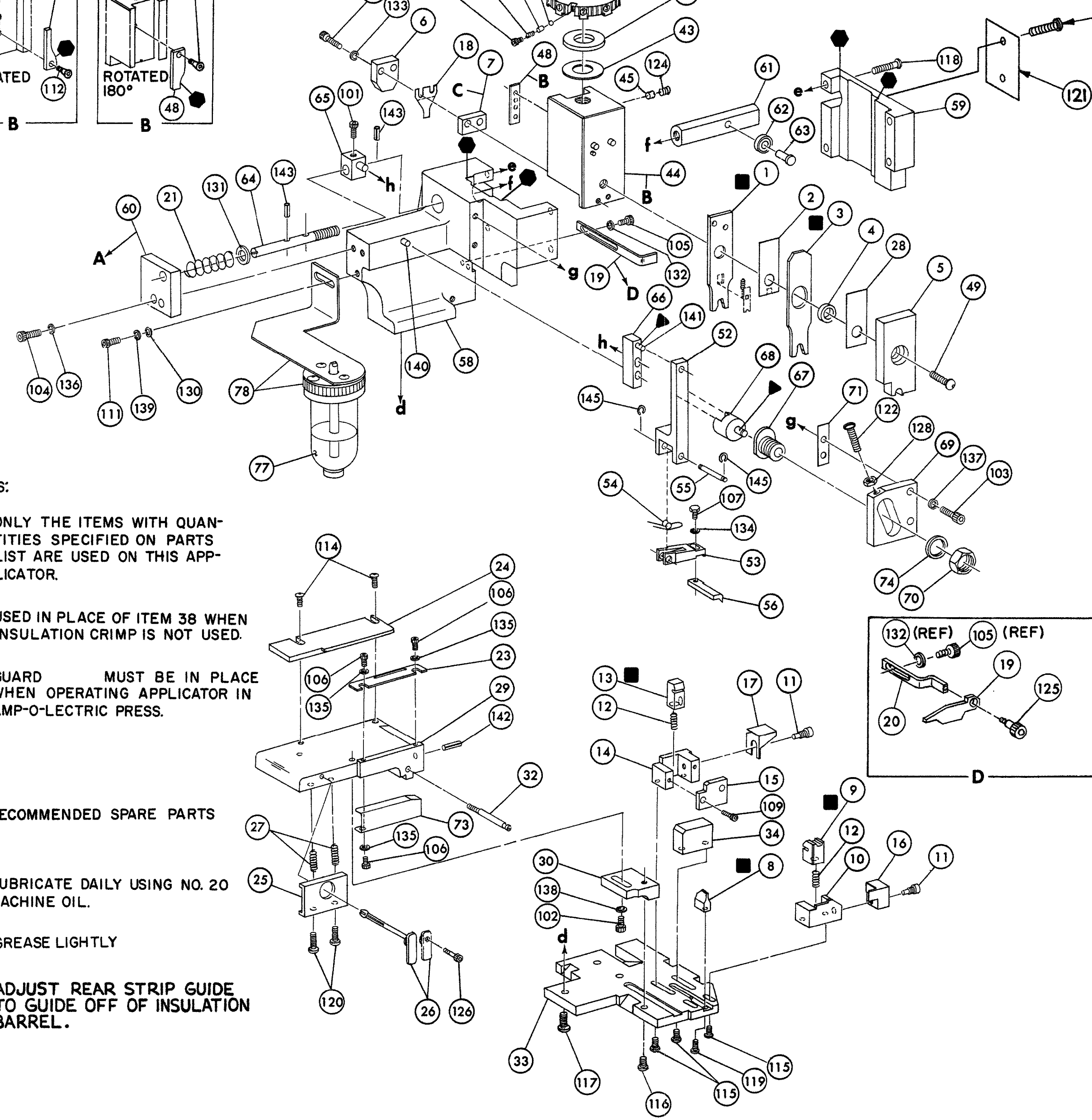
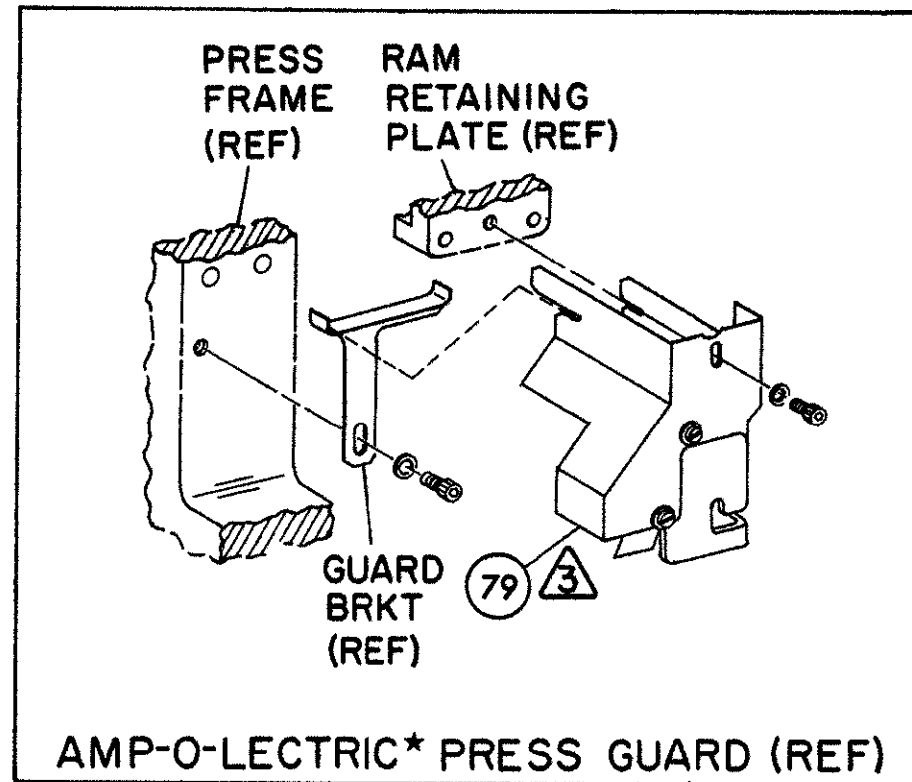
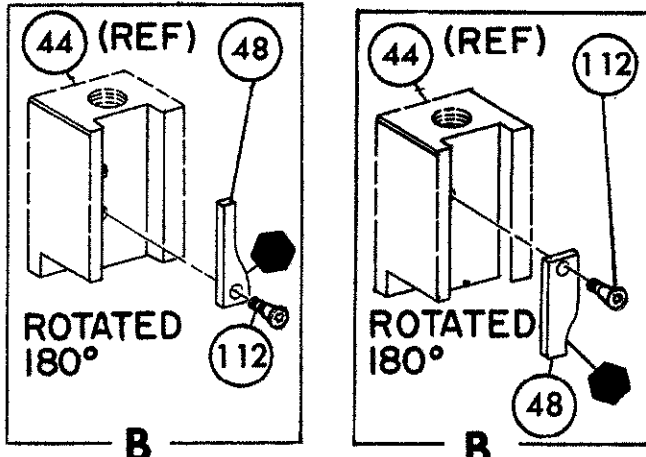

NOTES:

1.- ONLY THE ITEMS WITH QUANTITIES SPECIFIED ON PARTS LIST ARE USED ON THIS APPLICATOR.

△- USED IN PLACE OF ITEM 38 WHEN INSULATION CRIMP IS NOT USED.

△- GUARD MUST BE IN PLACE WHEN OPERATING APPLICATOR IN AMP-O-LECTRIC PRESS.

KEY:

■- RECOMMENDED SPARE PARTS

▲- LUBRICATE DAILY USING NO. 20 MACHINE OIL.

●- GREASE LIGHTLY

△- ADJUST REAR STRIP GUIDE TO GUIDE OFF OF INSULATION BARREL.

REF.	21045-3	RING, RETAINING 'C' (.187 DIA) FEED FINGER PIN	145	REF.	454220-1	CAP, HOUSING	59
REF.	5-21028-1	PIN, SLOT SPR (.125 DIA X .50) ADJ ROD	144	REF.	454485-1	HOUSING	58
1	4-21028-0	PIN, SLOT SPR (.093 DIA X .75) STR G PLATE	143	1	690542-2	PAWL, FEED	57
REF.	1-21030-1	PIN, DOWEL (.187 DIA X .50) LEVER	141	REF.	240624-1	PIN, FEED FINGER	55
REF.	1-21030-6	PIN, DOWEL (.187 DIA X 1.25) HOUSING	140	REF.	691499-1	SPRING, FEED FINGER	54
1	21024-5	WASHER, LOCK (NO 10) LUB ASSY	139	REF.	690541-1	FINGER, FEED	53
1	21024-5	WASHER, LOCK (NO 10) STRIP GUIDE ADJ BLOCK	138	REF.	455679-1	LEVER, TERMINAL FEED ARM	52
REF.	21024-5	WASHER, LOCK (NO 10) ADJ PLATE	137	1	811242-2	BUMPER, HOLDDOWN	51
REF.	21024-5	WASHER, LOCK (NO 10) FEED GUIDE ROD	136	1	690753-1	SPACER, TONKER	50
2	21024-2	WASHER, LOCK (NO 4) FRONT STRIP GUIDE	135	1	7-21002-9	BOLT, CRIMPER	49
1	21024-4	WASHER, LOCK (NO 8) FEED FINGER	134	1	690602-5	CAM PRE FEED 1/8 STROKE	48
2	21024-4	WASHER, LOCK (NO 8) DEPRESSOR	133				47
1	21024-4	WASHER, LOCK (NO 8) STRIPPER	132	1	459456-1	APPLICATOR, BASIC (SUB ASSY)	46
REF.	21899-4	WASHER, FLAT (5/16 DIA) SCREW ADJ	131	1	690191-1	PLUG, NYLON	45
1	21899-2	WASHER, FLAT (NO 10) LUB ASSY	130	1	455673-1	RAM	44
1	21018-5	NUT, HEX MACH (6-32) HOLDDOWN	129	1	690125-1	WASHER, LAMINATED	43
REF.	21018-5	NUT, HEX MACH (6-32) FEED ADJ	128	1	690124-1	WASHER, RAM	42
			127			DISC, SPACER	41
—	22353-8	SCR, SHLD. (.187 DIA X .250 LG) DRAG LEVER	126	2	23241-6	BALL, STEEL	40
1	456567-1	SCR, SHLD (.188 DIA X .125 LG) STRIPPER	125	2	690170-1	SPRING, COMPRESSION	39
1	21009-2	SCR, SKT SET (1/4-20 X .25) (LOC-WEL) RAM	124	1	690142-1	DISC, INSULATION	38
2	21017-2	SCR, DRIVE # 2 X .19	123	1	5-690692-6	DISC, WIRE	37
REF.	6-23715-5	SCR, RD HD MACH (6-32 X 1.50) FEED ADJ	122	1	22480-5	WASHER, SPRING	36
1	461264-1	PLATE, IDENTIFICATION	121	1	690212-1	POST, RAM	35
2	2-21002-9	SCR, BUT HD SKT CAP (10-32 X .75) DRAG	120	1	692776-1	SUPPORT, TERMINAL	34
1	22733-8	SCR, BUT HD SKT CAP (8-32 X .38) (LOC-WEL) ANVIL	119	REF.	455675-1	PLATE, BASE	33
REF.	2-21002-9	SCR, BUT HD SKT CAP (10-32 X .75) CAP	118	1	690432-3	SCREW, ADJUSTMENT	32
REF.	17177-1	SCR, BUT HD SKT CAP (1/4-20 X .75) HOUSING	117				31
REF.	2-21002-7	SCR, BUT HD SKT CAP (10-32 X .50) SG ADJ BLOCK	116	REF.	455689-1	BLOCK, STRIP GUIDE ADJ	30
4	2-21002-2	SCR, BUT HD SKT CAP (8-32 X .50) SHEAR	115	1	455671-1	PLATE, STRIP GUIDE	29
2	2-21002-2	SCR, BUT HD SKT CAP (8-32 X .50) R STRIP GUIDE	114	1	1-455888-0	SPACER, FRONT SHEAR DEPRESSOR	28
			113	2	1-22284-0	SPRING, DRAG	27
1	1-21002-7	SCR, BUT HD SKT CAP (6-32 X .38) CAM	112	1	690546-1	LEVER, DRAG RELEASE	26
1	3-21000-4	SCR, SKT HD CAP (10-32 X .38) LUBRICATOR ASSY	111	1	240792-1	DRAG, STOCK	25
2	23030-1	SCR, SKT HD CAP (6-32 X .25) (LOC-WEL) CP DISC	110	1	7-690504-1	GUIDE STRIP (REAR)	24
			109	1	690438-1	GUIDE, STRIP (FRONT)	23
2	2-21000-7	SCR, SKT HD CAP (8-32 X .50) DEPRESSOR	108				22
1	2-22603-0	SCR, HEX HD MACH (8-32 X .31) FEED FINGER	107	REF.	4-22284-9	SPRING, FEED RETURN	21
2	1-21000-3	SCR, SKT HD CAP (4-40 X .25) F STRIP GUIDE	106	1	458950-1	ARM, STRIPPER	20
1	2-21000-7	SCR, SKT HD CAP (8-32 X .50) STRIPPER	105	1	458949-1	STRIPPER	19
REF.	3-21000-7	SCR, SKT HD CAP (10-32 X .75) FEED ROD GUIDE	104				18
REF.	3-21000-6	SCR, SKT HD CAP (10-32 X .62) FEED ADJ BLOCK	103				17
1	3-21000-4	SCR, SKT HD CAP (10-32 X .38) SG ADJ BLOCK	102	1	691667-1	GUARD, CHIP (FRONT)	16
REF.	3-21000-4	SCR, SKT HD CAP (10-32 X .38) PIVOT BLOCK	101				15
REF.	455749-1	GUARD (WINDOW)	79				14
1	1-465184-0	LUBRICATOR ASSY	78				13
REF.	852931-2	OIL, LUBRICATING	77	1	5-22280-0	SPRING, SHEAR	12
			76	1	690461-1	STOP, SHEAR	11
			75	1	690459-1	HOLDER, SHEAR (FRONT)	10
REF.	458109-1	WASHER, SPECIAL	74	1	462006-1	SHEAR, FLOAT (FRONT)	9
—	454877-3	PLATE, STRIP GUIDE COVER	73	1	3-803653-4	ANVIL	8
2	690603-1	SPRING, ASSIST	72	1	3-240641-3	SPACER, DEPRESSOR (REAR)	7
REF.	690517-1	SPACER	71				6
↑	22594-8	NUT, HEX	70	1	455889-9	DEPRESSOR, SHEAR (FRONT)	5
	240628-1	PLATE, ADJUSTMENT	69	1	1-238011-0	SPACER, TUBULAR, INS CRIMPER	4
	240626-1	SHAFT, PIVOT	68	1	1-683453-2	CRIMPER, INSULATION	3
	240633-1	BUSHING	67	1	455888-8	SPACER, CRIMPER	2
	455680-1	LEVER, INTERMEDIATE	66	1	1-456402-7	CRIMPER, WIRE	1
	240629-1	BLOCK, PIVOT	65				
	240632-2	SCREW, ADJUSTMENT FEED ROD	64				
	240659-3	PIN, CAM ROLLER	63				
	240658-1	ROLLER, CAM	62				
↑	454398-2	ROD, FEED	61				
REF.	454178-1	GUIDE, FEED ROD	60				

QTY	PART NO	DESCRIPTION	ITEM NO	CRIMPING DATA				APPLICATOR WILL APPLY	
				PAD LTR	CRIMP HEIGHT	WIRE SIZE	WIRE STRIP LENGTH	PIN	SOCKET
	A	.030	22			745266	745269		
	B	.027	24 OR 26						
	C	NOT USED							
	D	NOT USED							
	CRIMP	SIZE	TYPE	FEED	APPL INST				
	WIRE	.055	F	.300	A1 8040				
	INSUL	.076	F						
	WIRE RANGE	26-22	INSULATION RANGE	.060 MAX.	PRESS NO	565435-5			
	REMARKS	AMP-O-LECTRIC PRE FEED							

REMARKS	NO	REV
APPL USED ON MACHINE PART NO	MACH SERIAL NO	DISTRIBUTION
CUSTOMER NAME	APPL SERIAL NO	ORIGINAL
ADDRESS	PURCHASE ORDER	CUSTOMER COPY
CITY	ENG APP	FIELD ENG COPY