

## General Description

The AOZ1083 is a high efficiency, simple to use, 1.2 A buck HB LED driver optimized for general lighting applications. The AOZ1083 operates from a 3 V to 26 V input voltage range and provides up to 1.2 A of continuous LED current. The 280 mV LED current feedback voltage minimizes the power dissipation of the external sense resistor. The fixed switching frequency of 1.5 MHz PWM operation reduces inductor and capacitor sizes.

The AOZ1083 is available in a tiny SOT23-6L package.

## Features

- Up to 26 V operating input voltage range
- 240 mΩ internal NMOS
- Up to 95 % efficiency
- Internal compensation
- 1.2 A continuous output current
- Fixed 1.5 MHz PWM operation
- Internal soft start
- 280 mV LED current feedback voltage with  $\pm 5\%$  accuracy
- Cycle-by-cycle current limit
- Short-circuit protection
- Thermal shutdown
- Small size SOT23-6L

## Applications

- Point of load DC/DC conversion
- Set top boxes
- DVD drives and HDD
- LCD Monitors & TVs
- Cable modems
- Telecom/Networking/Datacom equipment



## Typical Application

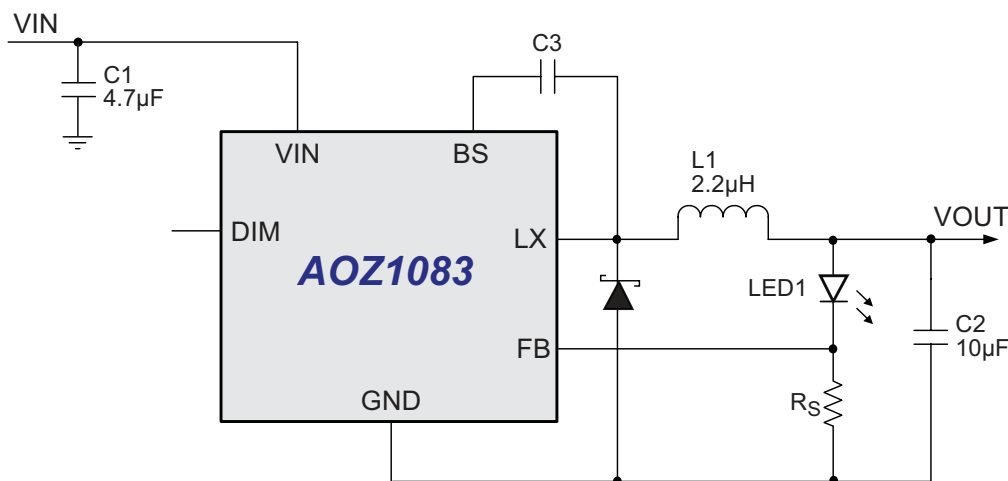

Figure 1. 1.2 A Buck HB LED Driver

## Ordering Information

Part Number	Ambient Temperature Range	Package	Environmental
AOZ1083CI	-40 °C to +85 °C	SOT23-6L	Green Product



AOS Green Products use reduced levels of Halogens, and are also RoHS compliant. Please visit [www.aosmd.com/web/quality/rohs\\_compliant.jsp](http://www.aosmd.com/web/quality/rohs_compliant.jsp) for additional information.

## Pin Configuration

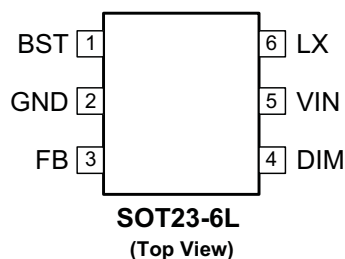

## Pin Description

Pin Number	Pin Name	Pin Function
1	BST	Bootstrap voltage input. High side driver supply. Connected to 10 nF capacitor between BST and LX.
2	GND	Ground.
3	FB	LED current feedback. The FB pin regulation voltage is 280 mV. Connect an external sense resistor between the cathode of the LED string and GND to set LED current.
4	DIM	PWM dimming pin. This pin is active high.
5	VIN	Supply voltage input. Input range from 3 V to 26 V. When VIN rises above the UVLO threshold the device starts up.
6	LX	PWM output connection to inductor.

## Absolute Maximum Ratings

Exceeding the Absolute Maximum Ratings may damage the device.

Parameter	Rating
Supply Voltage ( $V_{VIN}$ )	30 V
LX to GND	-0.7 V to $V_{VIN} + 2$ V
DIM to GND	-0.3 V to 26 V
FB to GND	-0.3 V to 6 V
BST to AGND	$V_{LX} + 6$ V
Junction Temperature ( $T_J$ )	+150 °C
Storage Temperature ( $T_S$ )	-65 °C to +150 °C
ESD Rating <sup>(1)</sup>	2 kV

**Note:**

1. Devices are inherently ESD sensitive, handling precautions are required. Human body model rating: 1.5 k $\Omega$  in series with 100 pF.

## Recommended Operating Conditions

The device is not guaranteed to operate beyond the Recommended Operating Conditions.

Parameter	Rating
Supply Voltage ( $V_{VIN}$ )	3.0 V to 26 V
Output Voltage Range	Up to 0.85x $V_{VIN}$
Ambient Temperature ( $T_A$ )	-40 °C to +85 °C
Package Thermal Resistance ( $\Theta_{JA}$ ) SOT23-6L <sup>(2)</sup>	220 °C/W

**Note:**

2. The value of  $\Theta_{JA}$  is measured with the device mounted on a 1-in<sup>2</sup> FR-4 board with 2 oz. Copper, in a still air environment with  $T_A = 25$  °C. The value in any given application depends on the user's specific board design.

## Electrical Characteristics

$T_A = 25$  °C,  $V_{VIN} = V_{DIM} = 12$  V. Specifications in **BOLD** indicate a temperature range of -40 °C to +85 °C. These specifications are guaranteed by design.

Symbol	Parameter	Conditions	Min.	Typ.	Max.	Units
$V_{VIN}$	Supply Voltage		<b>3</b>		<b>26</b>	V
$V_{UVLO}$	Input Under-Voltage Lockout Threshold	$V_{VIN}$ Rising $V_{VIN}$ Falling	2.3		2.9	V V
	UVLO Hysteresis			200		mV
$I_{VIN}$	Supply Current (Quiescent)	$I_{OUT} = 0$ , $V_{FB} = 1$ V, $V_{DIM} > 1.2$ V		<b>1</b>	<b>1.5</b>	mA
$I_{OFF}$	Shutdown Supply Current	$V_{DIM} = 0$ V			8	$\mu$ A
$V_{FB}$	Feedback Voltage	$T_A = 25$ °C	266	280	294	mV
$V_{FB\_LOAD}$	Load Regulation	120 mA < Load < 1.08 A		0.5		%
$V_{FB\_LINE}$	Line Regulation	Load = 600 mA		0.03		% / V
$I_{FB}$	Feedback Voltage Input Current	$V_{FB} = 280$ mV		500		nA
<b>PWM DIMMING</b>						
$V_{Dim\_OFF}$ $V_{Dim\_ON}$	Dimming Input Threshold	Off Threshold On Threshold	<b>1.2</b>		<b>0.4</b>	V V
$V_{Dim\_HYS}$	Dimming Input Hysteresis			200		mV
$I_{DIM}$	Dimming Input Current				3	$\mu$ A
<b>MODULATOR</b>						
$f_O$	Frequency		1.2	1.5	1.8	MHz
$D_{MAX}$	Maximum Duty Cycle			87		%
$T_{ON\_MIN}$	Minimum On Time			100		ns
$I_{LIM}$	Current Limit		1.5	1.9	2.3	A
	Over-Temperature Shutdown Limit	$T_J$ Rising $T_J$ Falling		150 110		°C °C
$T_{SS}$	Soft Start Interval			400		$\mu$ s
<b>POWER STATE OUTPUT</b>						
$R_{DS(ON)}$	NMOS On-Resistance	$V_{IN} = 12$ V		240		m $\Omega$
$R_{DS(ON)}$	NMOS On-Resistance	$V_{IN} = 3.3$ V		380		m $\Omega$
$I_{LEAKAGE}$	NMOS Leakage	$V_{DIM} = 0$ V, $V_{LX} = 0$ V			10	$\mu$ A

### Block Diagram

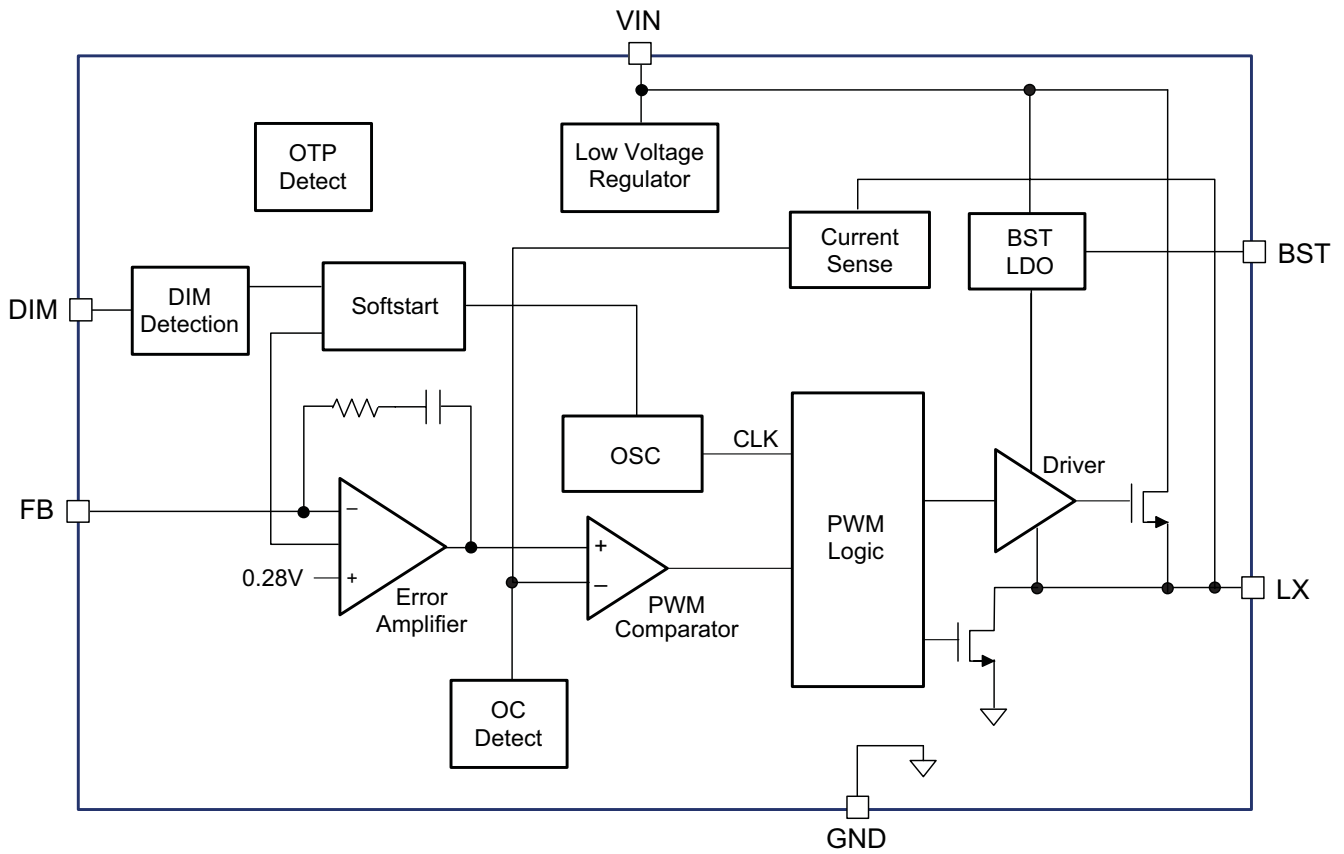

## Typical Performance Characteristics

Circuit of Figure 1.  $V_{VIN} = 12\text{ V}$ , Load = 1 W White LED unless otherwise specified.

### Steady State Test

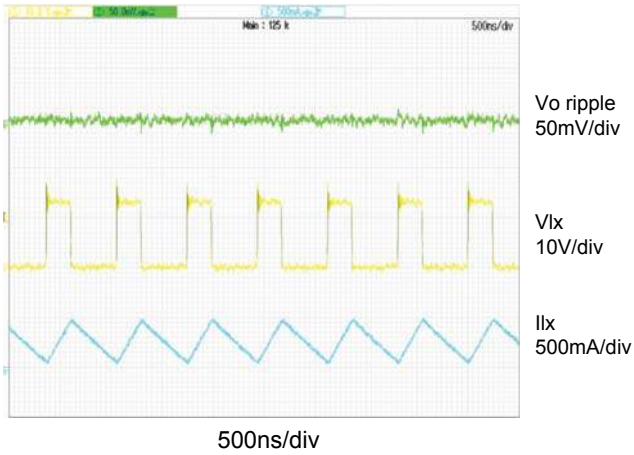

### Dimming Startup Test

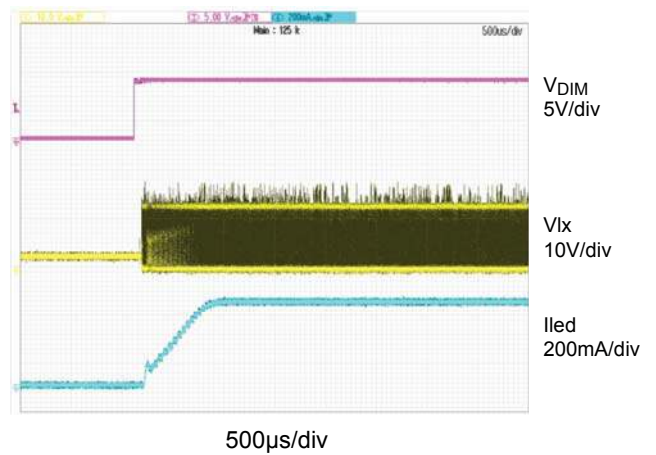

### Dimming Shutdown Test

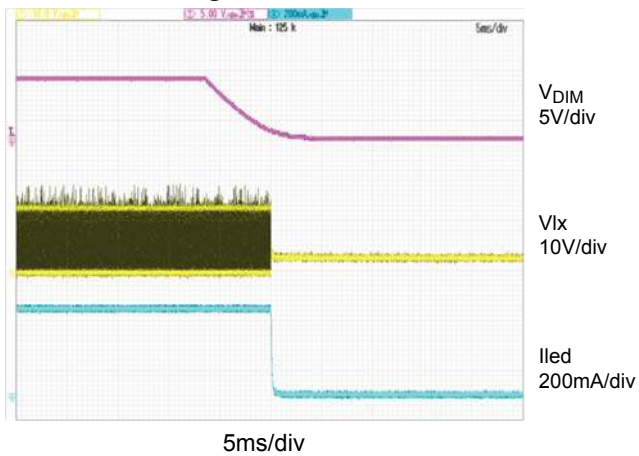

### LED Short Test

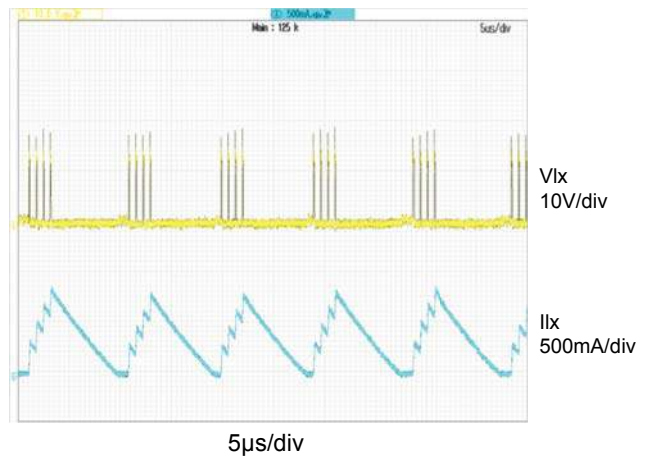

### LED Short Protection

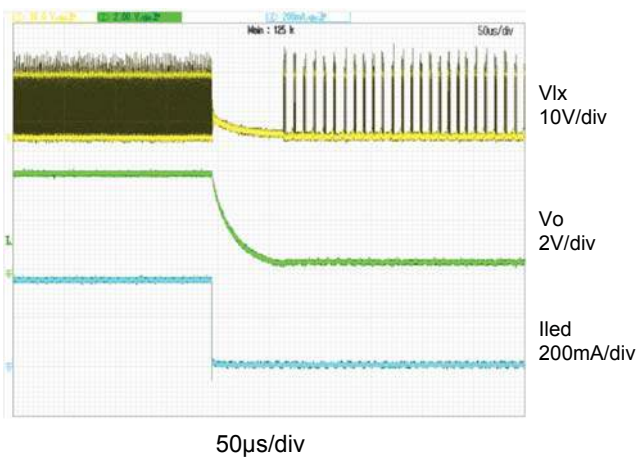

### LED Short Recovery

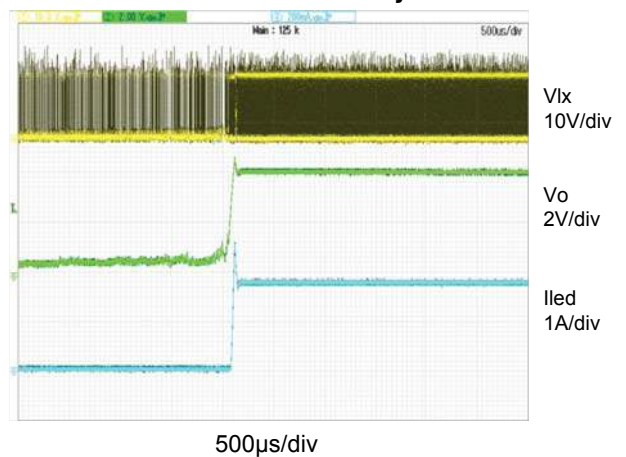

## Detailed Description

The AOZ1083 is a high efficiency, simple to use, 1.2 A buck HB LED driver optimized for general lighting applications. Features include enable control, under voltage lock-out, internal soft-start, output over-voltage protection, over-current protection and thermal shut down.

The AOZ1083 is available in a SOT23-6L package.

### Soft Start and PWM Dimming

The AOZ1083 has an internal soft start feature to limit in-rush current and ensure the output voltage ramps up smoothly to regulation voltage. A soft start process begins when the input voltage rises to a voltage higher than UVLO and the voltage on the Dim pin is HIGH. In the soft start process, the output voltage is typically ramped to regulation voltage in 400  $\mu$ s. The 400  $\mu$ s soft start time is set internally.

The DIM pin of the AOZ1083 is active high. Connect the DIM pin to VIN if the enable function is not used. Pulling DIM to ground will disable the AOZ1083. Do not leave it open. The voltage on the DIM pin must be above 1.2 V to enable the AOZ1083. When voltage on the DIM pin falls below 0.4 V, the AOZ1083 is disabled.

### Steady-State Operation

Under steady-state conditions, the converter operates in fixed frequency and Continuous-Conduction Mode (CCM).

The AOZ1083 integrates an internal NMOS as the high-side switch. Inductor current is sensed by amplifying the voltage drop across the drain to source of the high side power MOSFET. Output voltage is divided down by the external voltage divider at the FB pin. The difference of the FB pin voltage and reference voltage is amplified by the internal transconductance error amplifier. The error voltage is compared against the current signal, which is the sum of inductor current signal and ramp compensation signal, at the PWM comparator input. If the current signal is less than the error voltage, the internal high-side switch is on. The inductor current flows from the input through the inductor to the output. When the current signal exceeds the error voltage, the high-side switch is off. The inductor current is freewheeling through the external Schottky diode to output.

### Switching Frequency

The AOZ1083 switching frequency is fixed and set by an internal oscillator. The switching frequency is set internally 1.5 MHz.

### LED Current Programming

LED current can be set by feeding back the output to the FB pin with the sense resistor  $R_S$  shown in Figure 1. The LED current can be programmed as:

$$I_{LED} = \frac{0.28}{R_S}$$

### Protection Features

The AOZ1083 has multiple protection features to prevent system circuit damage under abnormal conditions.

#### Over Current Protection (OCP)

The sensed inductor current signal is also used for over current protection.

The cycle-by-cycle current limit threshold is set at 2 A. When the load current reaches the current limit threshold, the cycle-by-cycle current limit circuit immediately turns off the high side switch to terminate the current duty cycle. The inductor current stops rising. The cycle-by-cycle current limit protection directly limits inductor peak current. The average inductor current is also limited due to the limitation on peak inductor current. When cycle-by-cycle current limit circuit is triggered, the output voltage drops as the duty cycle decreases.

The AOZ1083 has an internal short circuit protection to protect itself from catastrophic failure under output short circuit conditions. As a result, the converter is shut down and hiccups. The converter will start up via a soft start once the short circuit condition is resolved. In short circuit protection mode, the inductor average current is greatly reduced.

#### UVLO

An UVLO circuit monitors the input voltage. When the input voltage exceeds 2.9 V, the converter starts operation. When the input voltage falls below 2.3 V, the converter will stop switching.

### Thermal Protection

An internal temperature sensor monitors the junction temperature. It shuts down the internal control circuit and high side NMOS if the junction temperature exceeds 150° C. The regulator will restart automatically under the control of the soft-start circuit when the junction temperature decreases to 100 °C.

## Application Information

The basic AOZ1083 application circuit is shown in Figure 1. Component selection is explained below.

### Input Capacitor

The input capacitor must be connected to the VIN pin and PGND pin of the AOZ1083 to maintain steady input voltage and filter out the pulsing input current. The voltage rating of the input capacitor must be greater than the maximum input voltage plus ripple voltage.

The input ripple voltage can be approximated by equation below::

$$\Delta V_{IN} = \frac{I_O}{f \times C_{IN}} \times \left(1 - \frac{V_O}{V_{IN}}\right) \times \frac{V_O}{V_{IN}}$$

Since the input current is discontinuous in a buck converter, the current stress on the input capacitor is another concern when selecting the capacitor. For a buck circuit, the RMS value of the input capacitor current can be calculated by:

$$I_{CIN\_RMS} = I_O \times \sqrt{\frac{V_O}{V_{IN}} \left(1 - \frac{V_O}{V_{IN}}\right)}$$

if we let m equal the conversion ratio:

$$\frac{V_O}{V_{IN}} = m$$

The relationship between the input capacitor RMS current and voltage conversion ratio is calculated and shown in Figure 2. It can be seen that when  $V_O$  is half of  $V_{IN}$ ,  $C_{IN}$  is under the worst current stress. The worst current stress on  $C_{IN}$  is at  $0.5 \times I_O$ .

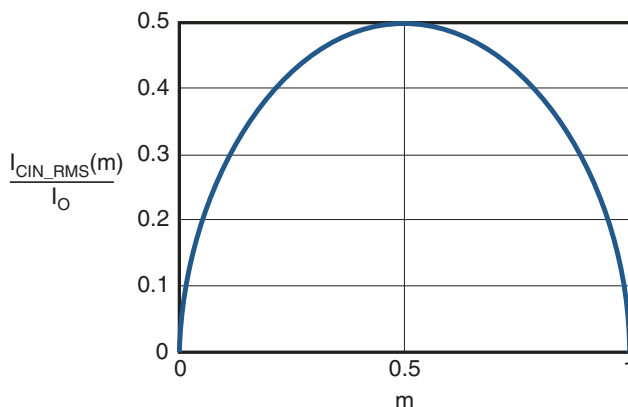

Figure 2.  $I_{CIN}$  vs. Voltage Conversion Ratio

For reliable operation and best performance, the input capacitors must have current rating higher than  $I_{CIN\_RMS}$  at the worst operating conditions. Ceramic capacitors are preferred for input capacitors because of their low ESR and high ripple current rating. Depending on the application circuits, other low ESR tantalum capacitor or aluminum electrolytic capacitor may also be used. When selecting ceramic capacitors, X5R or X7R type dielectric ceramic capacitors are preferred for their better temperature and voltage characteristics. Note that the ripple current rating from capacitor manufacturers are based on a certain life time. Further de-rating may need to be considered for long term reliability.

### Inductor

The inductor is used to supply constant current to output when it is driven by a switching voltage. For a given input and output voltage, inductance and switching frequency together decide the inductor ripple current, which is:

$$\Delta I_L = \frac{V_O}{f \times L} \times \left(1 - \frac{V_O}{V_{IN}}\right)$$

The peak inductor current is:

$$I_{Lpeak} = I_O + \frac{\Delta I_L}{2}$$

High inductance provides low inductor ripple current but requires a larger size inductor to avoid saturation. Low ripple current reduces inductor core losses. It also reduces RMS current through inductor and switches, which results in less conduction loss.

When selecting the inductor, confirm it is able to handle the peak current without saturation even at the highest operating temperature.

The inductor takes the highest current in a buck circuit. The conduction loss on inductor needs to be checked for thermal and efficiency requirements.

Surface mount inductors in different shape and styles are available from Coilcraft, Elytone and Murata. Shielded inductors are small and radiate less EMI noise but cost more than unshielded inductors. The choice depends on EMI requirement, price and size.

### Output Capacitor

The output capacitor is selected based on the DC output voltage rating, output ripple voltage specification and ripple current rating.

The selected output capacitor must have a higher rated voltage specification than the maximum desired output voltage including ripple. De-rating needs to be considered for long term reliability.

Output ripple voltage specification is another important factor for selecting the output capacitor. In a buck converter circuit, output ripple voltage is determined by inductor value, switching frequency, output capacitor value and ESR. It can be calculated by the equation below:

$$\Delta V_O = \Delta I_L \times \left( ESR_{CO} + \frac{1}{8 \times f \times C_O} \right)$$

where,

$C_O$  is output capacitor value, and

$ESR_{CO}$  is the equivalent series resistance of the output capacitor.

When a low ESR ceramic capacitor is used as the output capacitor, the impedance of the capacitor at the switching frequency dominates. Output ripple is mainly caused by capacitor value and inductor ripple current. The output ripple voltage calculation can be simplified to:

$$\Delta V_O = \Delta I_L \times \frac{1}{8 \times f \times C_O}$$

If the impedance of ESR at switching frequency dominates, the output ripple voltage is mainly decided by the capacitor ESR and inductor ripple current. The output ripple voltage calculation can be further simplified to:

$$\Delta V_O = \Delta I_L \times ESR_{CO}$$

For lower output ripple voltage across the entire operating temperature range, X5R or X7R dielectric type of ceramic, or other low ESR tantalum capacitors or aluminum electrolytic capacitors may also be used as output capacitors.

In a buck converter, output capacitor current is continuous. The RMS current of output capacitor is decided by the peak inductor ripple current. It can be calculated by:

$$I_{CO\_RMS} = \frac{\Delta I_L}{\sqrt{12}}$$

Usually, the ripple current rating of the output capacitor is a smaller issue because of the low current stress. When the buck inductor is selected to be very small and inductor ripple current is high, the output capacitor could be overstressed.

### Schottky Diode Selection

The external freewheeling diode supplies the current to the inductor when the high side NMOS switch is off. To reduce the losses due to the forward voltage drop and recovery of diode, Schottky diode is recommended to use. The maximum reverse voltage rating of the chosen Schottky diode should be greater than the maximum input voltage, and the current rating should be greater than the maximum load current.

### Thermal Management and Layout Considerations

In the AOZ1083 buck regulator circuit, high pulsing current flows through two circuit loops. The first loop starts from the input capacitors, to the VIN pin, to the LX pin, to the filter inductor, to the output capacitor and load, and then returns to the input capacitor through ground. Current flows in the first loop when the high side switch is on. The second loop starts from the inductor, to the output capacitor and load, to the anode of Schottky diode, to the cathode of Schottky diode. Current flows in the second loop when the low side diode is on.

In PCB layout, minimizing the area of the two loops reduces the noise of the circuit and improves efficiency. A ground plane is strongly recommended to connect input capacitor, output capacitor, and PGND pin of the AOZ1083.

In the AOZ1083 buck regulator circuit, the major power dissipating components are the AOZ1083, the Schottky diode and output inductor. The total power dissipation of the converter circuit can be measured by input power minus output power:

$$P_{total\_loss} = (V_{IN} \times I_{IN}) - (V_O \times I_{IN})$$

The power dissipation in the Schottky diode can be approximated as:

$$P_{diode\_loss} = I_O \times (1 - D) \times V_{FW\_Schottky}$$

where,

$V_{FW\_Schottky}$  is the Schottky diode forward voltage drop.

The power dissipation of the inductor can be approximately calculated by output current and DCR of the inductor.

$$P_{inductor\_loss} = I_O^2 \times R_{inductor} \times 1.1$$



The actual junction temperature can be calculated with power dissipation in the AOZ1281 and thermal impedance from junction to ambient.

$$T_{junction} = (P_{total\_loss} - P_{diode\_loss} - P_{inductor\_loss}) \times \Theta_{JA} + T_{amb}$$

The maximum junction temperature of AOZ1083 is 150 °C, which limits the maximum load current capability.

The thermal performance of the AOZ1083 is strongly affected by the PCB layout. Care should be taken during the design process to ensure that the IC will operate under the recommended environmental conditions.

Several layout tips are listed below for the best electric and thermal performance.

1. The input capacitor should be connected as close as possible to the VIN pin and the GND pin.
2. The inductor should be placed as close as possible to the LX pin and the output capacitor.
3. Keep the connection of schottky diode between the LX pin and the GND pin as short and wide as possible.
4. Place the feedback resistors and compensation components as close to the chip as possible.
5. Keep sensitive signal traces away from the LX pin.
6. Pour a maximized copper area to the VIN pin, the LX pin and especially the GND pin to help thermal dissipation.
7. Pour copper plane on all unused board areas and connect the plane to stable DC nodes, like VIN, GND or VOUT.

Package Dimensions, SOT23-6

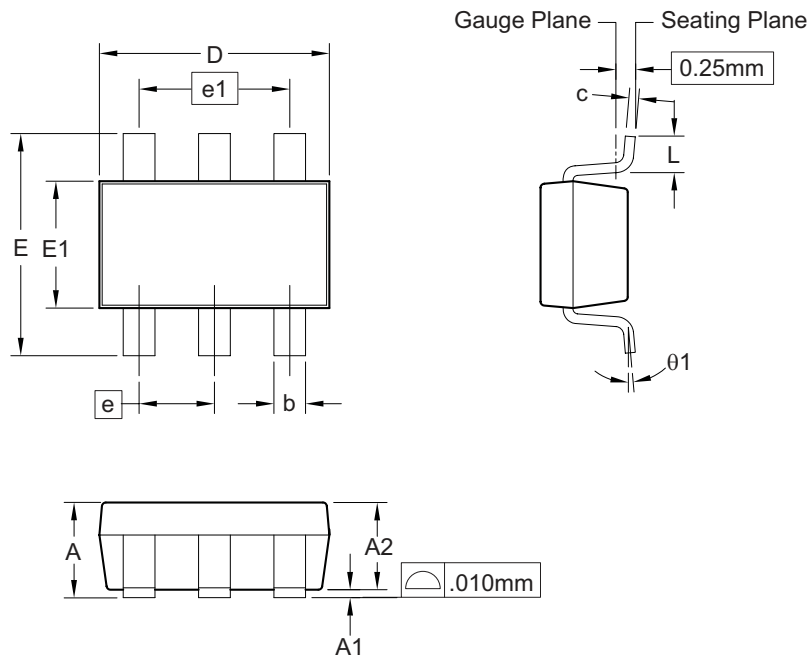

RECOMMENDED LAND PATTERN

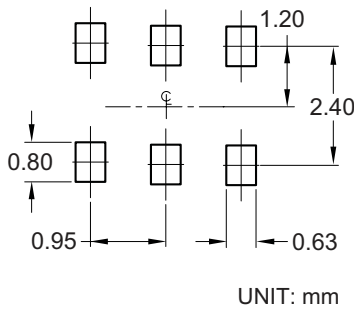

Dimensions in millimeters

Symbols	Min.	Nom.	Max.
A	0.90	—	1.25
A1	0.00	—	0.15
A2	0.70	1.10	1.20
b	0.30	0.40	0.50
c	0.08	0.13	0.20
D	2.70	2.90	3.10
E	2.50	2.80	3.10
E1	1.50	1.60	1.70
e	0.95 BSC		
e1	1.90 BSC		
L	0.30	—	0.60
θ1	0°	—	8°

Dimensions in inches

Symbols	Min.	Nom.	Max.
A	0.035	—	0.049
A1	0.00	—	0.006
A2	0.028	0.043	0.047
b	0.012	0.016	0.020
c	0.003	0.005	0.008
D	0.106	0.114	0.122
E	0.098	0.110	0.122
E1	0.059	0.063	0.067
e	0.037 BSC		
e1	0.075 BSC		
L	0.012	—	0.024
θ1	0°	—	8°

Notes:

1. Package body sizes exclude mold flash and gate burrs. Mold flash at the non-lead sides should be less than 5 mils each.
2. Dimension "L" is measured in gauge plane.
3. Tolerance ±0.100 mm (4 mil) unless otherwise specified.
4. Followed from JEDEC MO-178C & MO-193C.
5. Controlling dimension is millimeter. Converted inch dimensions are not necessarily exact.

### Tape and Reel Dimensions, SOT23-6

#### Tape

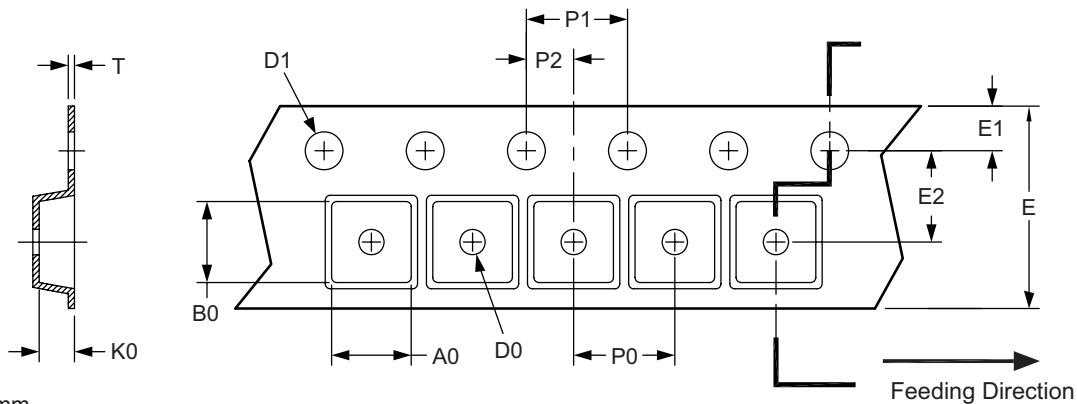

Unit: mm

Package	A0	B0	K0	D0	D1	E	E1	E2	P0	P1	P2	T
SOT-23	3.15 ±0.10	3.27 ±0.10	1.34 ±0.10	1.10 ±0.01	1.50 ±0.10	8.00 ±0.20	1.75 ±0.10	3.50 ±0.05	4.00 ±0.10	4.00 ±0.10	2.00 ±0.10	0.25 ±0.05

#### Reel

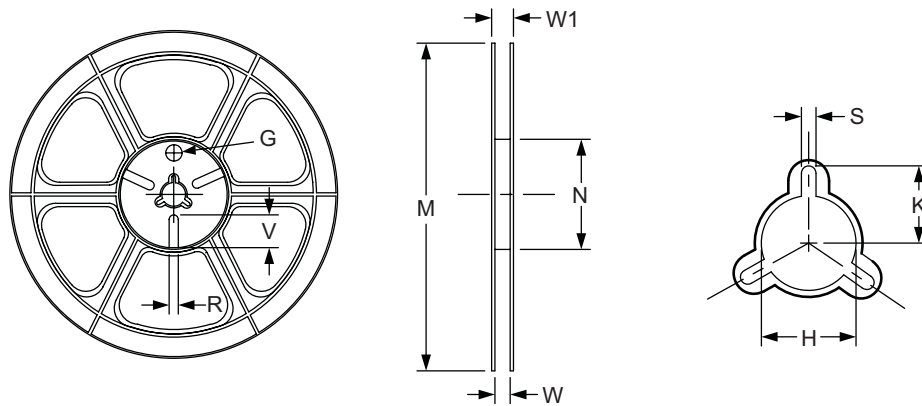

Unit: mm

Tape Size	Reel Size	M	N	W	W1	H	K	S	G	R	V
8 mm	ø180	ø180.00 ±0.50	ø60.50 Min.	9.00 ±0.30	11.40 ±1.0	ø13.00 +0.50 / -0.20	10.60	2.00 ±0.50	ø9.00	5.00	18.00

#### Leader/Trailer and Orientation

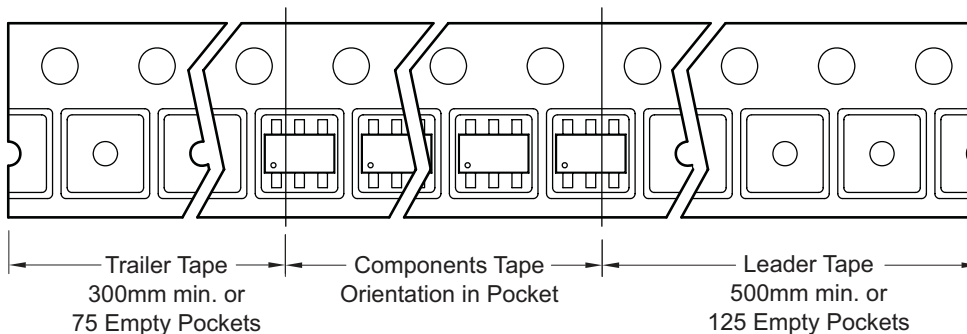

**Part Marking**

**AOZ1083CI  
(SOT23-6)**

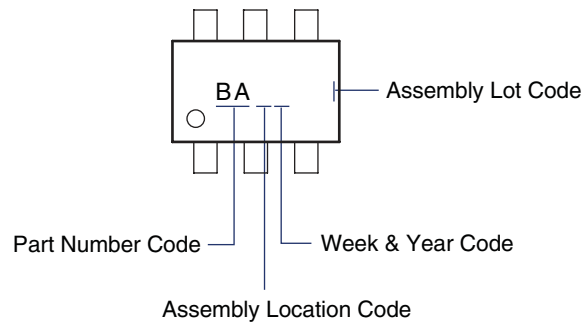

**LEGAL DISCLAIMER**

Applications or uses as critical components in life support devices or systems are not authorized. AOS does not assume any liability arising out of such applications or uses of its products. AOS reserves the right to make changes to product specifications without notice. It is the responsibility of the customer to evaluate suitability of the product for their intended application. Customer shall comply with applicable legal requirements, including all applicable export control rules, regulations and limitations.

AOS' products are provided subject to AOS' terms and conditions of sale which are set forth at:

[http://www.aosmd.com/terms\\_and\\_conditions\\_of\\_sale](http://www.aosmd.com/terms_and_conditions_of_sale)

**LIFE SUPPORT POLICY**

ALPHA & OMEGA SEMICONDUCTOR PRODUCTS ARE NOT AUTHORIZED FOR USE AS CRITICAL COMPONENTS IN LIFE SUPPORT DEVICES OR SYSTEMS.

As used herein:

1. Life support devices or systems are devices or systems which, (a) are intended for surgical implant into the body or (b) support or sustain life, and (c) whose failure to perform when properly used in accordance with instructions for use provided in the labeling, can be reasonably expected to result in a significant injury of the user.

2. A critical component in any component of a life support, device, or system whose failure to perform can be reasonably expected to cause the failure of the life support device or system, or to affect its safety or effectiveness.