

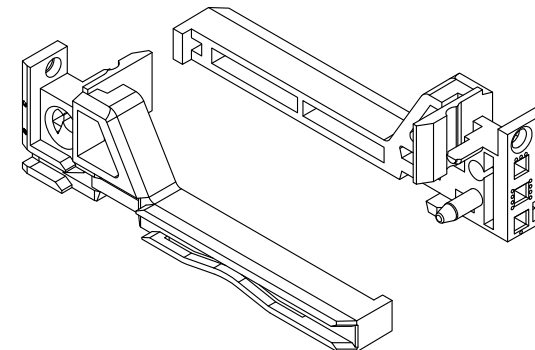

| REV. | DESCRIPTION | DATE | APPROVED |
|------|----------------------|----------|----------|
| B | Engineering Release. | 11/20/14 | J. C. |
| | | | |
| | | | |
| | | | |

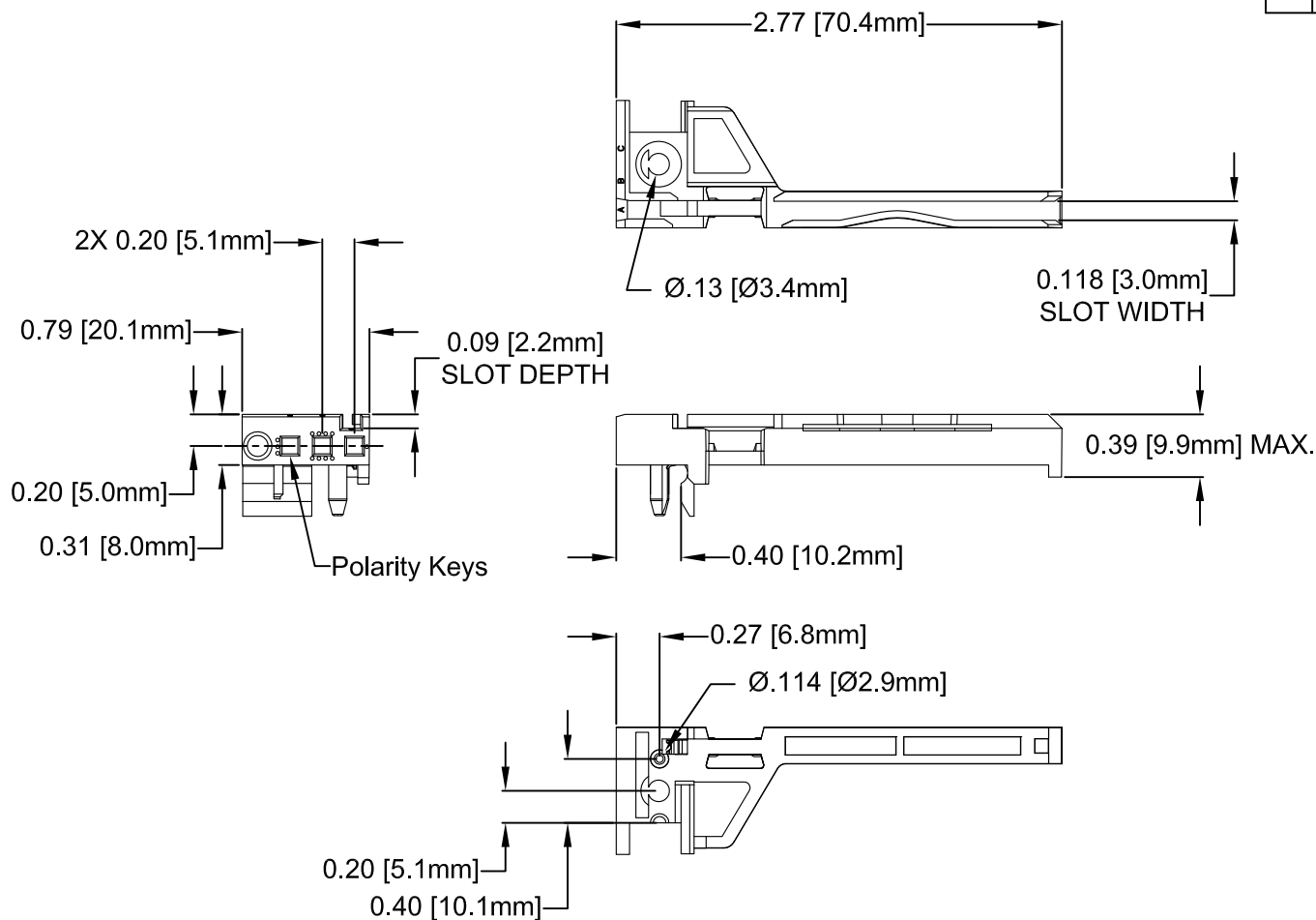

| PART NUMBER | COLOR |
|-------------|--------|
| CPCI-TG-B | GREY |
| CPCI-TGY-B | YELLOW |

2. MATERIAL: POLYCARBONATE, 20% GLASS FILLED

1. GENERAL SPECIFICATIONS: BIVAR MOLDED COMPONENT SPECIFICATION BV00-E101.

| | | | |
|--|--------------------------|---|-----------------------|
| STANDARD TOLERANCE (UNLESS OTHERWISE SPECIFIED) | |  4 THOMAS, IRVINE, CA. 92618 TEL: (949) 951-8808 FAX: (949) 951-3974 | |
| DECIMALS | ANGULAR | | |
| .X ±.1 | X° ± 1° | | |
| .XX ±.01 | |  TITLE: TRANSITION CARD GUIDE BOTTOM | |
| .XXX ±.005 | | | |
| DESIGNED: Alex Wright | DATE: 08/21/14 | PART NO: CPCI-TGX-B | REVISION: B |
| CHECKED: Brian Oliver | DATE: 08/21/14 | CAGE CODE : 32559 | SHEET # 1 OF 1 |
| CAD GENERATED DOCUMENT, DO NOT MEASURE DRAWING. | | | |