

THIS DRAWING IS UNPUBLISHED. RELEASED FOR PUBLICATION
 © COPYRIGHT - By - ALL RIGHTS RESERVED.

LOC		DIST		REVISIONS			
P	LTR	DESCRIPTION		DATE	DWN	APVD	
AF	50	D		REVISED PER ECR-13-004343	31JUL13	KH	KR

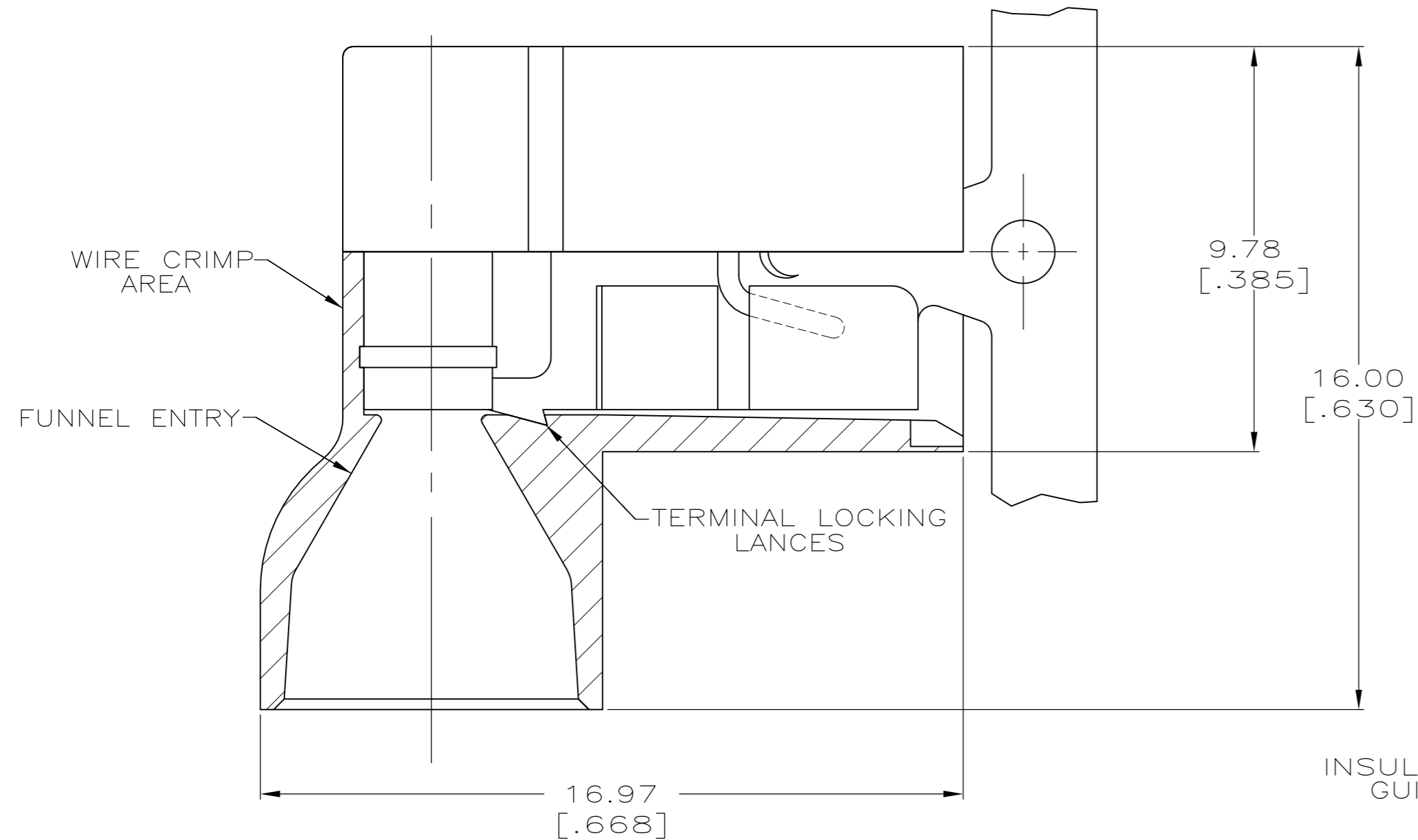

- 1 FITS 0.81±0.025 X 6.35 [.032±.001 X .250] TAB
- 2 WIRE SIZE: 1.3–2.0mm² [16–14 AWG], STRANDED ONLY.
 ONE WIRE STRIP LENGTH 7.94 [.312]
 TWO WIRE STRIP LENGTH 8.51 [.335]
- 3 INSULATION SIZE: 6.60 [.260] MAX DIA.
- 4 CONTINUOUS STRIP

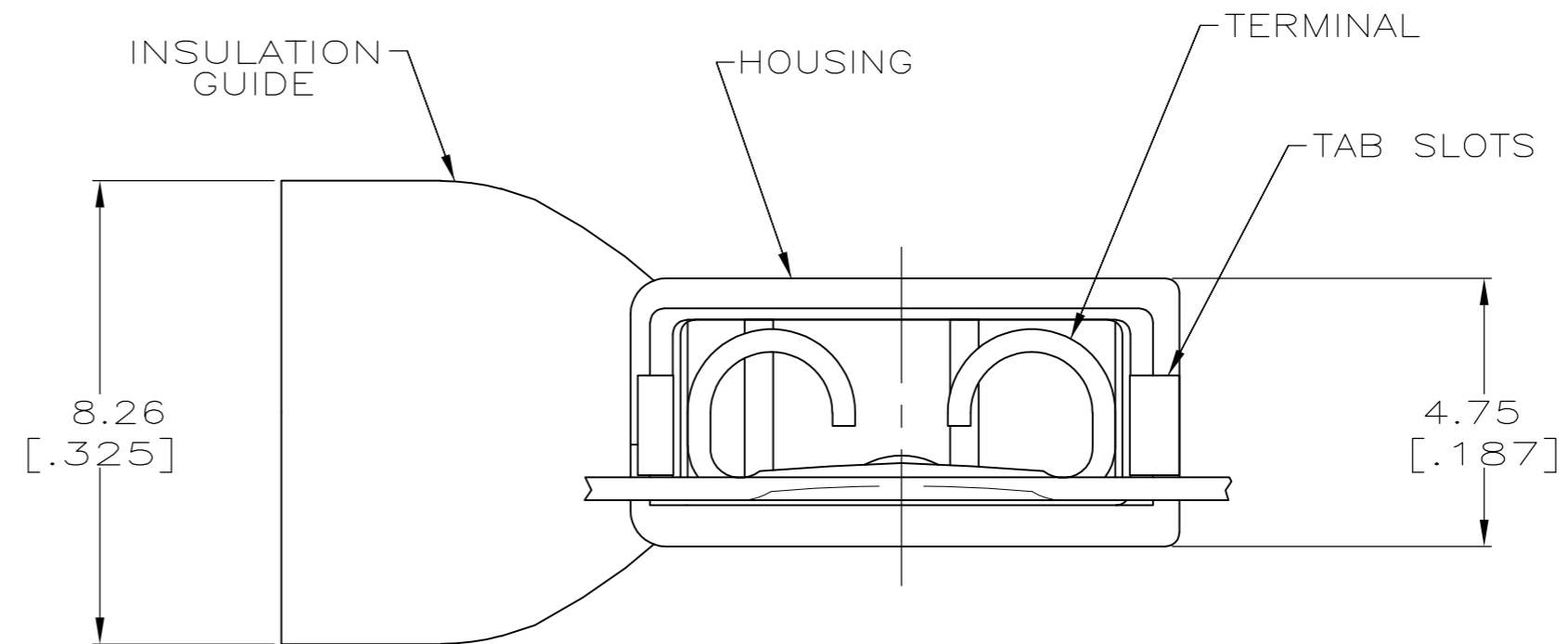
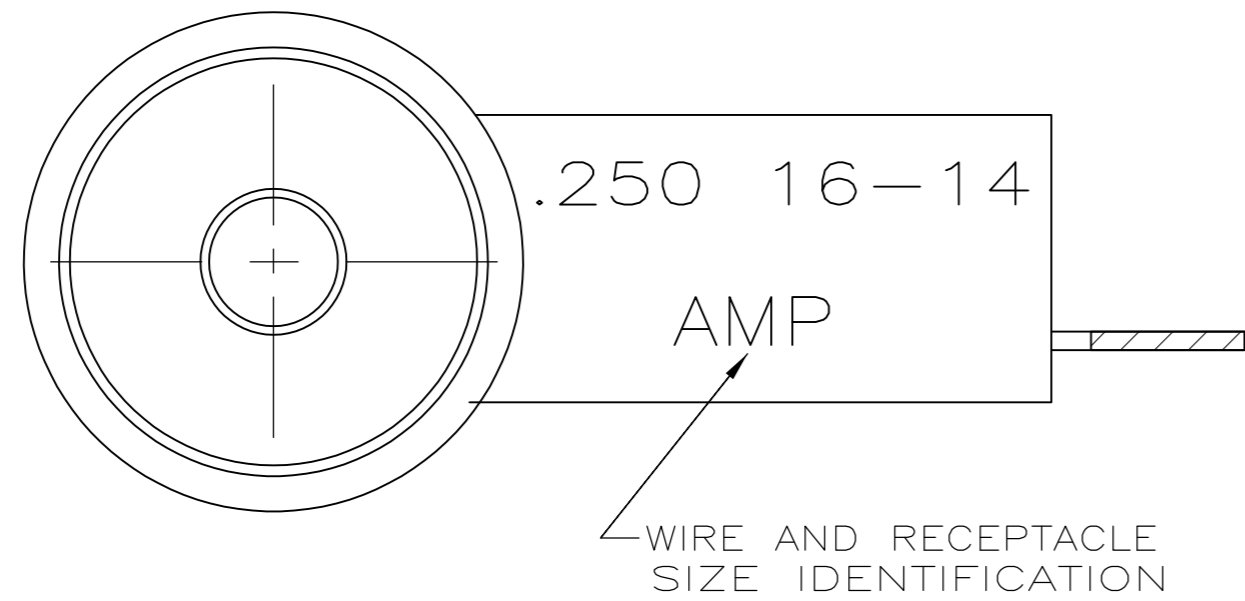

BULK	TYPE 6/6 NYLON	BLUE TRANSLUCENT	BRASS	TIN	5-521013-2
STANDARD					3-521013-2
PACKAGING	MATERIAL	COLOR	MATERIAL	FINISH	PART NUMBER
	HOUSING		TERMINAL		

THIS DRAWING IS A CONTROLLED DOCUMENT.		DWN	JR RUTH	12/22/92	 TE Connectivity RECEPTACLE ASSEMBLY, ULTRA-FAST FLAG, 6.35 [.250] SERIES
DIMENSIONS: mm [INCHES]		CHK	MS FEHER	12/22/92	
TOLERANCES UNLESS OTHERWISE SPECIFIED:		APVD	DJ BRATINA	12/22/92	
0 PLC ± - 1 PLC ± - 2 PLC ± - 3 PLC ± 0.38 [.015] 4 PLC ± - ANGLES ± -		PRODUCT SPEC	108-2043	NAME	
MATERIAL	SEE TABLE	FINISH	SEE TABLE	WEIGHT	SIZE
					CAGE CODE
					DRAWING NO
					RESTRICTED TO
					SCALE
					SHEET
					REV