

THIS DRAWING IS UNPUBLISHED. RELEASED FOR PUBLICATION
 © COPYRIGHT - By - ALL RIGHTS RESERVED.

REVISIONS					
P	LTR	DESCRIPTION	DATE	DWN	APVD
N2		REVISED PER ECO-16-004223	19JUL2016	NK	MZ

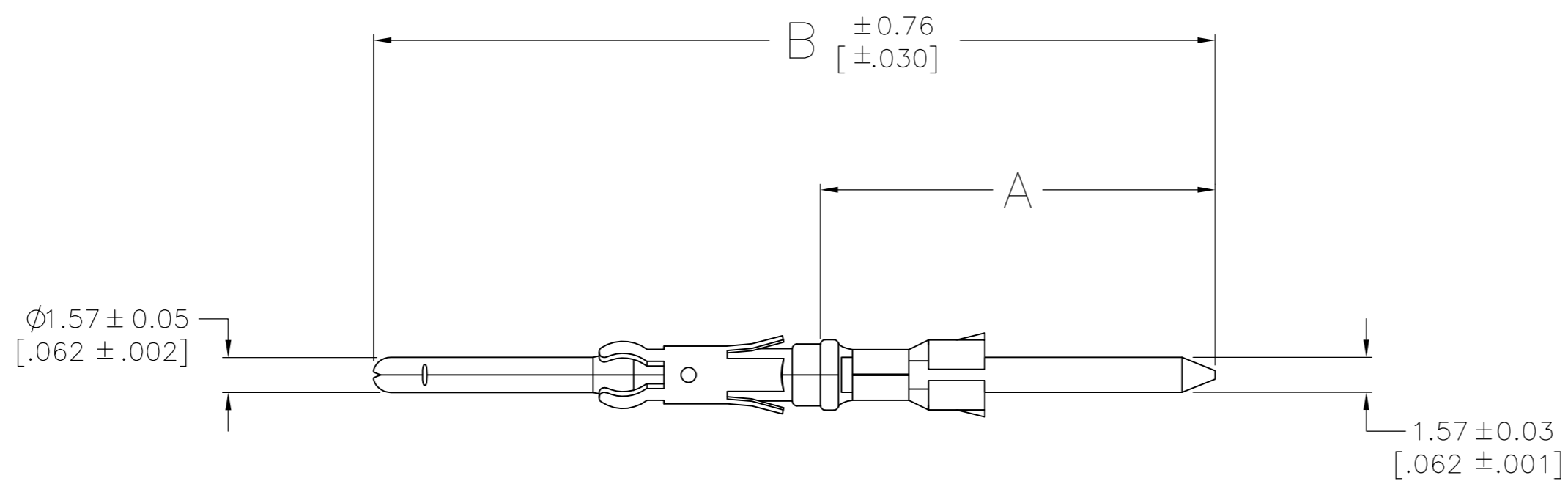

- ① BRASS PER ASTM B-36.
- ② 2.54um[.0000100] MIN TIN-LEAD OVER 1.27um[.000050] MIN NICKEL.
- ③ SELECTIVELY PLATED 0.76um[.000030] MIN GOLD, FOR A DISTANCE OF 5.08[.200] FROM MATING END, GOLD FLASH ON REMAINDER, ALL OVER 1.27um[.000050] MIN NICKEL.
- 4 GOLD PLATING NOT TO APPEAR ON INSULATION SUPPORT STABILIZER.
- ⑤ POST WILL ACCEPT (SEE TABLE) TERMINATIONS.
- ⑥ 2.54um[.0000100] MIN TIN OVER 1.27um[.000050] MIN NICKEL.
- ⑦ OBSOLETE PARTS: OBSOLETE CIS STREAMLINING PER D.RENAUD/D.SINISI.

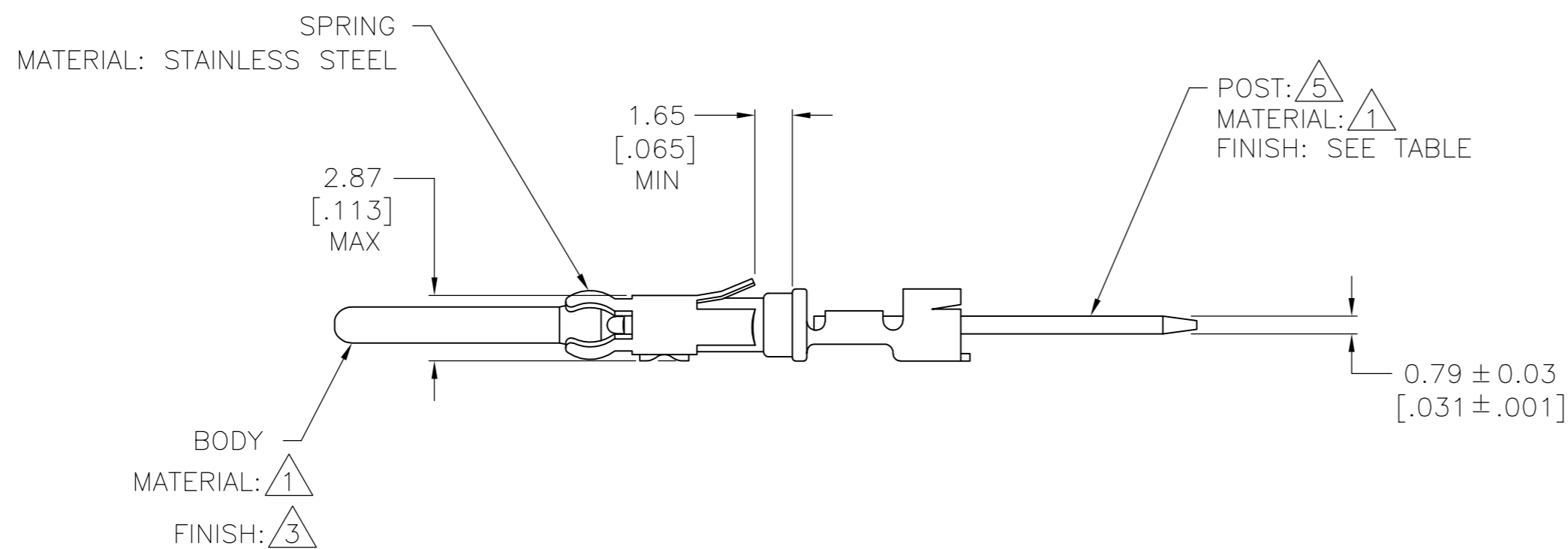

OBSOLETE	⑥	3	49.89 [1.964]	29.74 [1.171]	1-66470-1
OBSOLETE	⑥	1	37.97 [1.495]	17.81 [.701]	1-66470-0
	②	3	49.89 [1.964]	29.74 [1.171]	66470-9
⑦ SUPERSEDED	②	1	37.97 [1.495]	17.81 [.701]	66470-7
		POST PLATING	NO OF TERM	B	A
					PART NUMBER

THIS DRAWING IS A CONTROLLED DOCUMENT.		DWN C.REIFSNYDER 07 JUN 96			
DIMENSIONS: mm [INCHES]		CHK R.STONE 12 JUL 96			
TOLERANCES UNLESS OTHERWISE SPECIFIED:		APVD G.A.STEINHAUER 23 JUL 96	NAME		
0 PLC ± -		PRODUCT SPEC	PIN CONTACT, CRIMPED, .062 DIA, .031 x .062 POST, WRAP TYPE		
1 PLC ± -		APPLICATION SPEC	SIZE A2	CAGE CODE 00779	DRAWING NO C-66470
2 PLC ± 0.25[.010]		WEIGHT -	SCALE 4:1	SHEET 1 of 1	REV N2
3 PLC ± -		CUSTOMER DRAWING			
4 PLC ± -					
ANGLES ± -					
FINISH SEE CALLOUTS					

66470

B

A