

Features

- Guaranteed 2.7V and 5V performance
- Industrial temperature range (-40°C to +85°C)
- Low supply current: 60 µA per Channel
- Input Common Mode Voltage (V₋+0.2V to V₊-0.2V)
- Low output saturation voltage @ 200 mV
- Manufactured in standard CMOS process
- MSOP-8L, SOP-8L, and TSSOP-14L available in "Green" Molding Compound (No Br, Sb)
- Lead-free Finish / RoHS Compliant (Note 3)

General Description



The APX393/339 are low voltage (2.5V to 5.5V) dual and quad comparators. The APX393 is the dual version available in the 8-pin SOP and MSOP packages. The APX339 is the quad version available in 14-pin TSSOP package. The APX393/339 are designed to efficiently minimize cost, space, and power consumption for portable consumer products. They have open drain output to connect to the logic supply through a pull-up resistor and allow interfacing to a variety of logic families.

Applications

- Mobile communications
- Notebooks and PDA's
- Battery powered electronics
- General purpose portable device
- General purpose low voltage applications

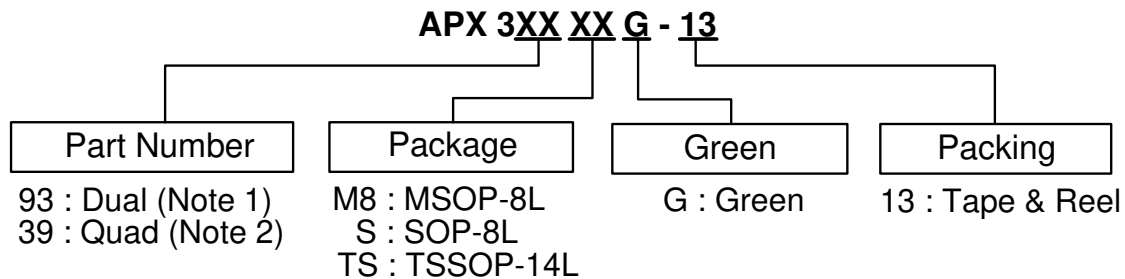
Ordering Information



Device	Package Code	Packaging (Note 4)	13" Tape and Reel	
			Quantity	Part Number Suffix
 APX393M8G-13	M8	MSOP-8L	2500/Tape & Reel	-13
 APX393SG-13	S	SOP-8L	2500/Tape & Reel	-13
 APX339TSG-13	TS	TSSOP-14L	2500/Tape & Reel	-13

- Notes:
1. APX393 is only available for MSOP-8L and SOP-8L.
 2. APX339 is only available for TSSOP-14L.
 3. EU Directive 2002/95/EC (RoHS). All applicable RoHS exemptions applied. Please visit our website at http://www.diodes.com/products/lead_free.html
 4. Pad layout as shown on Diodes Inc. suggested pad layout document AP02001, which can be found on our website at <http://www.diodes.com/datasheets/ap02001.pdf>.

Pin Assignments

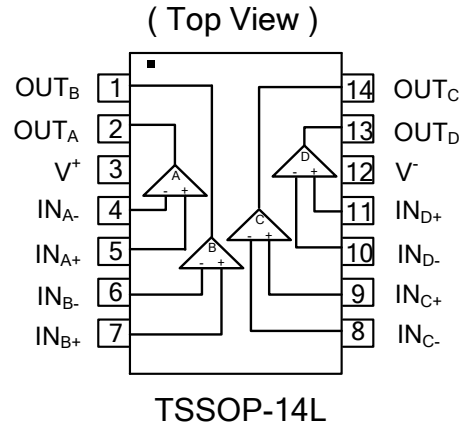
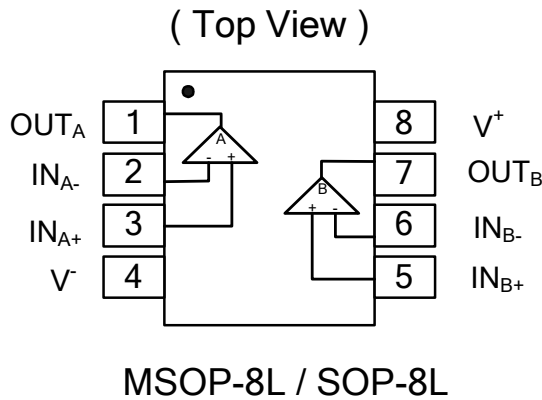

Absolute Maximum Ratings (Note 5)

Symbol	Description	Rating	Unit	
ESD HBM	Human Body Model	APX393	4000	V
		APX339	3500	
ESD MM	Machine Model	APX393	400	V
		APX339	400	
	Differential Input Voltage	±Supply Voltage	V	
	Voltage On Any Pin (Referred to V ⁻ Pin)	5.5	V	
T _{ST}	Storage Temperature	-65 to 150	°C	
T _J	Maximum Junction Temperature	150	°C	

Operating Ratings (Note 5)

Symbol	Description	Rating	Unit
V ⁺ -V ⁻	Supply Voltage	2.5 to 5.5	V
T _A	Operating Temperature Range	-40 to +85	°C

Notes: 5. Absolute Maximum Ratings indicate limits beyond which damage to the device may occur. Operating Ratings indicate conditions for which the device is intended to be functional, but specific performance is not guaranteed. For guaranteed specifications and the test conditions, see the Electrical Characteristics.

Electrical Characteristics

2.7V DC Electrical Characteristics

Unless otherwise specified, all limits guaranteed for $T_A = 25^\circ\text{C}$, $V^+ = 2.7\text{V}$, $V^- = 0\text{V}$. Boldface limits apply at the temperature extremes.

Symbol	Parameter	Test Conditions	Min (Note 7)	Typ. (Note 6)	Max (Note 7)	Unit
V_{OS}	Input Offset Voltage			1.7	7	mV
TCV_{OS}	Input Offset Voltage Average Drift			5		$\mu\text{V}/^\circ\text{C}$
I_B	Input Bias Current			10	250 400	nA
I_{OS}	Input Offset Current			5	50 150	nA
V_{CM}	Input Voltage Range			0.2		V
				2.5		V
V_{SAT}	Saturation Voltage	$I_{SINK} \leq 1\text{mA}$		200		mV
I_O	Output Sink Current	$V_O \leq 1.5\text{V}$	5	20		mA
I_S	Supply Current	APX393 Both Comparators		150	180	μA
		APX339 All four Comparators		240	300	μA
	Output Leakage Current			0.003	1	μA

2.7V AC Electrical Characteristics

$T_A = 25^\circ\text{C}$, $V^+ = 2.7\text{V}$, $R_L = 5.1\text{ k}\Omega$, $V^- = 0\text{V}$.

Symbol	Parameter	Test Conditions	Min (Note 7)	Typ. (Note 6)	Max (Note 7)	Unit
T_{PHL}	Propagation Delay (High to Low)	Input Overdrive = 10mV		700		ns
		Input Overdrive = 100mV		150		ns
T_{PLH}	Propagation Delay (Low to High)	Input Overdrive = 10mV		500		ns
		Input Overdrive = 100mV		200		ns

Electrical Characteristics (Continued)

5V DC Electrical Characteristics

Unless otherwise specified, all limits guaranteed for $T_A = 25^\circ\text{C}$, $V^+ = 5\text{V}$, $V^- = 0\text{V}$. **Boldface** limits apply at the temperature extremes.

Symbol	Parameter	Test Conditions	Min (Note 7)	Typ. (Note 6)	Max (Note 7)	Unit
V_{OS}	Input Offset Voltage			1.7	7 9	mV
TCV_{OS}	Input Offset Voltage Average Drift			5		$\mu\text{V}/^\circ\text{C}$
I_B	Input Bias Current			25	250 400	nA
I_{OS}	Input Offset Current			2	50 150	nA
V_{CM}	Input Voltage Range			0.2		V
				4.8		V
A_V	Voltage Gain	$R_L = 5.1\text{ k}\Omega$	20	50		V/mV
V_{SAT}	Saturation Voltage	$I_{SINK} \leq 4\text{mA}$		200	400 700	mV
I_O (Sink)	Output Sink Current	$V_O \leq 1.5\text{V}$	10	60		mA
I_S	Supply Current	APX393 Both Comparators		150	180 250	μA
		APX339 All four Comparators		240	300 350	μA
	Output Leakage Current			.003	1	μA
θ_{JA}	Thermal Resistance Junction-to -Ambient	MSOP-8L (Note 8)		203		$^\circ\text{C}/\text{W}$
		SOP-8L (Note 8)		150		$^\circ\text{C}/\text{W}$
		TSSOP-14L (Note 8)		100		$^\circ\text{C}/\text{W}$

5V AC Electrical Characteristics

$T_A = 25^\circ\text{C}$, $V^+ = 5\text{V}$, $R_L = 5.1\text{ k}\Omega$, $V^- = 0\text{V}$.

Symbol	Parameter	Test Conditions	Min (Note 7)	Typ. (Note 6)	Max (Note 7)	Unit
T_{PHL}	Propagation Delay (High to Low)	Input Overdrive = 10mV		600		ns
		Input Overdrive = 100mV		200		ns
T_{PLH}	Propagation Delay (Low to High)	Input Overdrive = 10mV		450		ns
		Input Overdrive = 100mV		300		ns

Notes: 6. Typical values represent the most likely parametric norm as determined at the time of characterization. Actual typical values may vary over time and will also depend on the application and configuration. The typical values are not tested and are not guaranteed on shipped production material.

7. All limits are guaranteed by testing or statistical analysis.

8. All numbers are typical, and apply for packages soldered directly onto a PC board in still air.

Typical Performance Characteristics

Unless otherwise specified, $V_s=+5V$, single supply, $T_A=25^\circ C$

Supply Current vs. Supply Voltage Output High

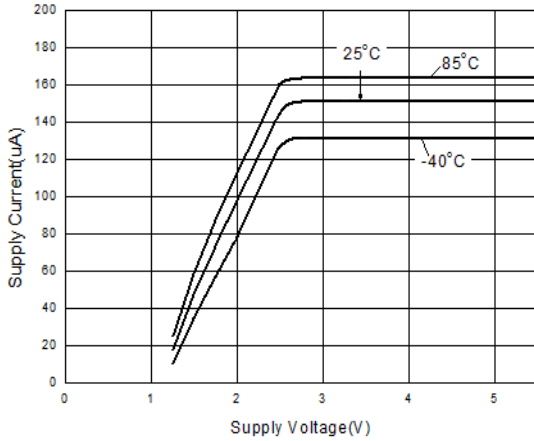

Supply Current vs. Supply Voltage Output Low

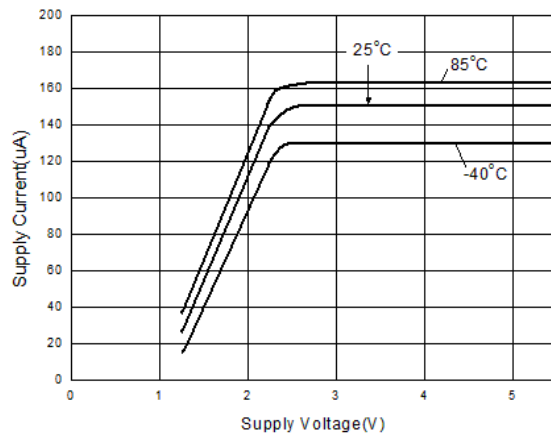

Output Voltage vs. Output Current (5V)

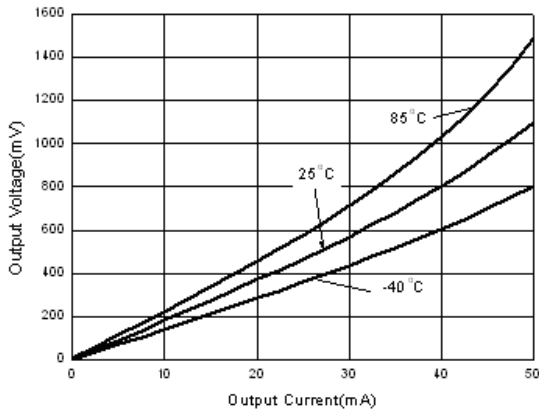

Output Voltage vs. Output Current (2.7V)

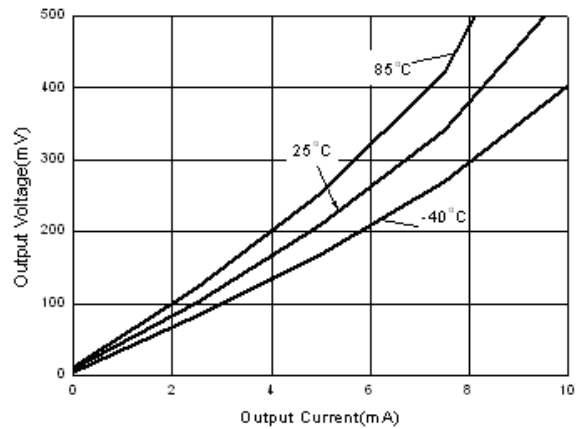

Marking Information

(1) MSOP-8L

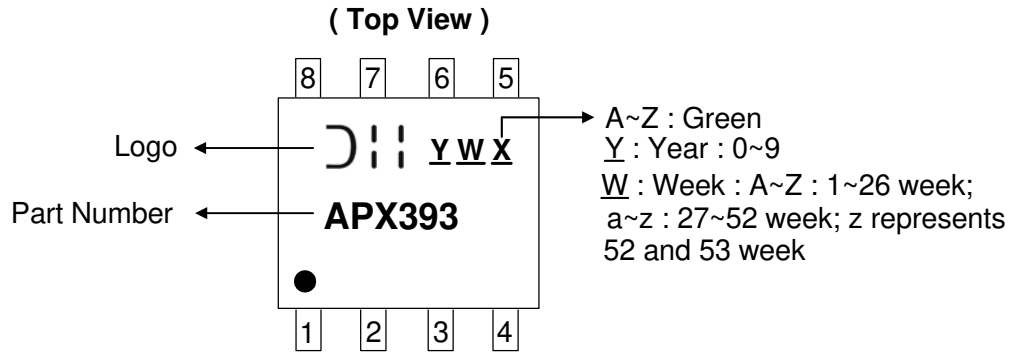

(2) SOP-8L

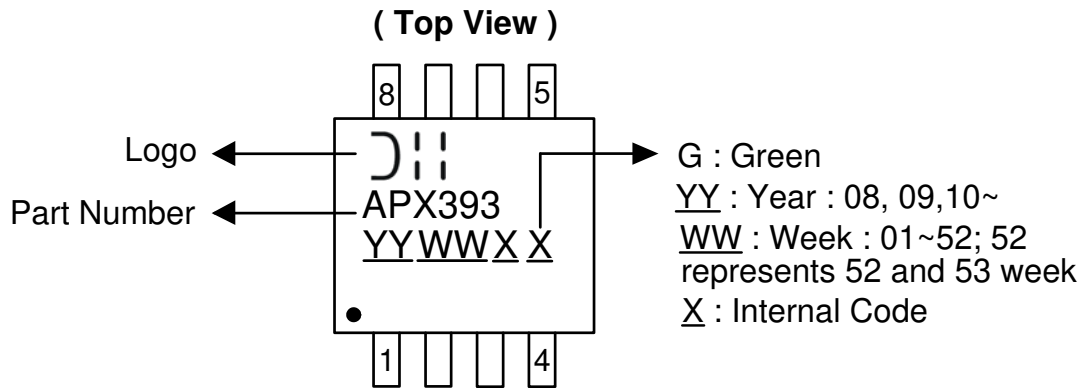

(3) TSSOP-14L

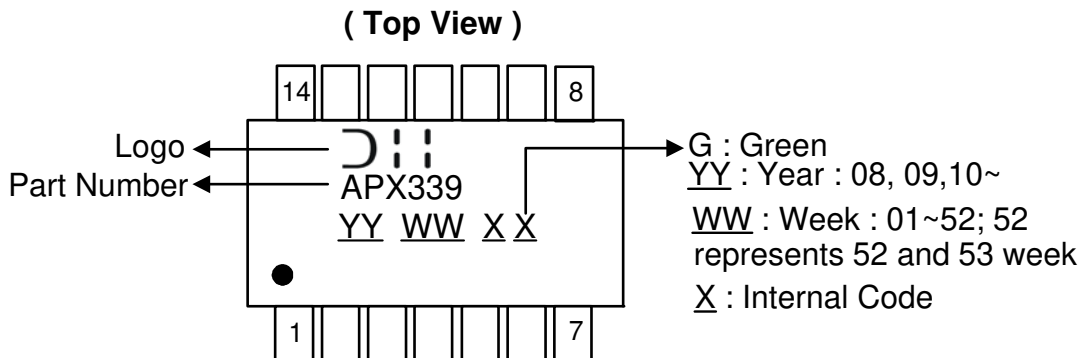

Package Information (All Dimensions in mm)

(1) Package type: MSOP-8L

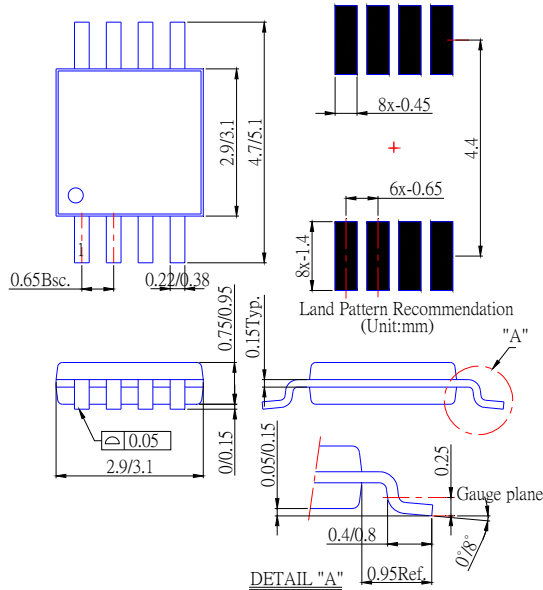

(2) Package type: SOP-8L

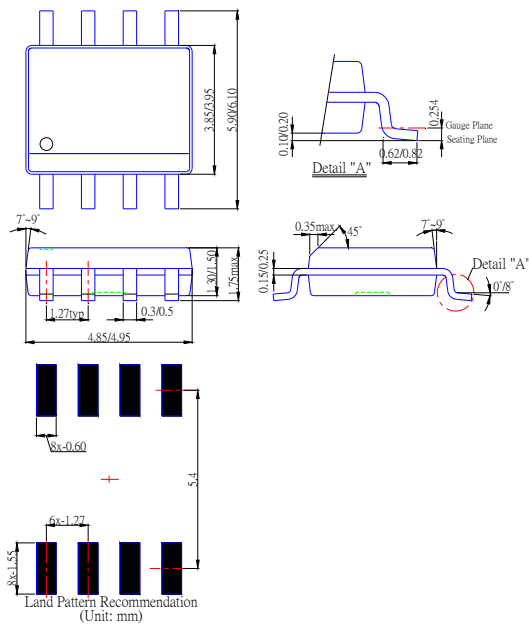

Package Information (Continued)

(3) Package type: TSSOP-14L

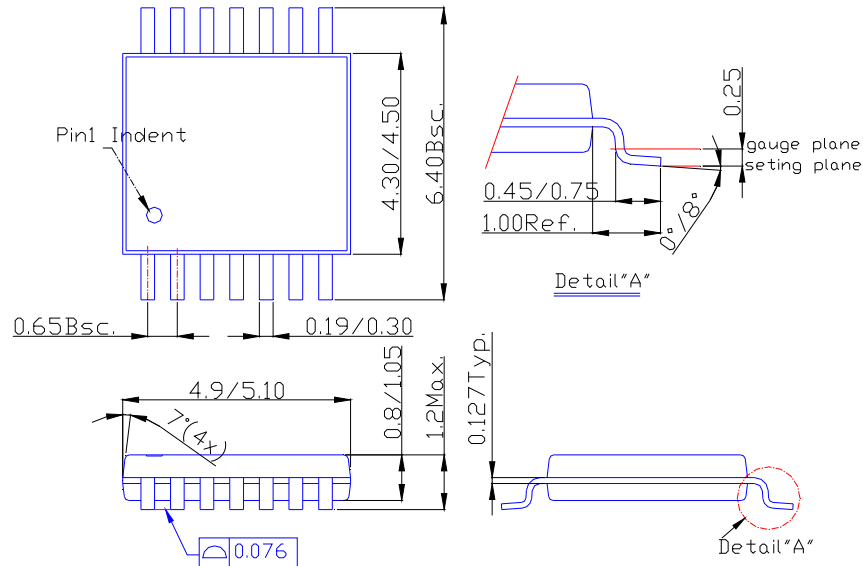

IMPORTANT NOTICE

Diodes Incorporated and its subsidiaries reserve the right to make modifications, enhancements, improvements, corrections or other changes without further notice to any product herein. Diodes Incorporated does not assume any liability arising out of the application or use of any product described herein; neither does it convey any license under its patent rights, nor the rights of others. The user of products in such applications shall assume all risks of such use and will agree to hold Diodes Incorporated and all the companies whose products are represented on our website, harmless against all damages.

LIFE SUPPORT

Diodes Incorporated products are not authorized for use as critical components in life support devices or systems without the expressed written approval of the President of Diodes Incorporated.