

NO.	DESCRIPTION	PART NO.	QTY	MATERIAL	DRW NO.	REMARKS
1	CONNECTOR	10 5738 009 210 859 +	250	—————		
2	EMBOSS TAPE	—————	1	POLYSTYRENE (CLEAR)		
3	TOP COVER TAPE	—————	1	POLYSTYRENE		
4	REEL	—————	1	CORRUGATED CARDBOARD or PLYSTYRENE		

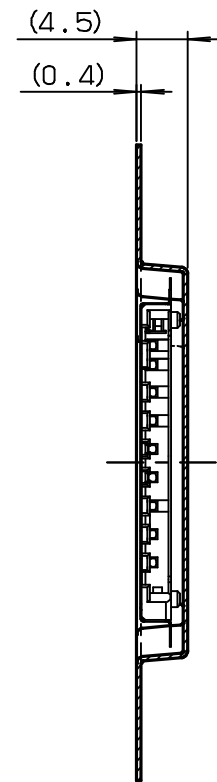
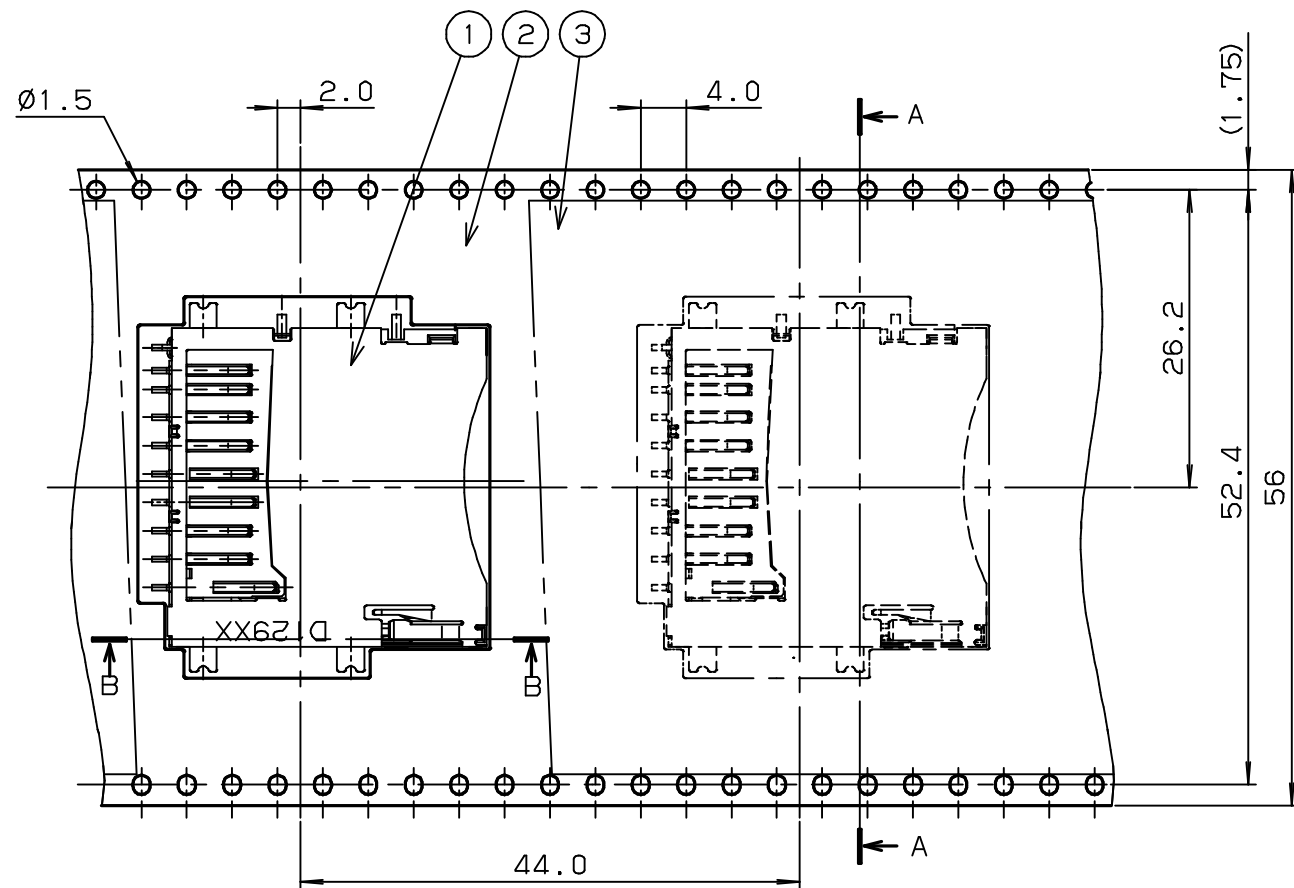

SECT. A-A

注記
NOTE

1. 梱包数量 : 250 個/リール
PACKING QUANTITY : 250 ea/reel

2. 納入時のリール巻方向
REELING DIRECTION IN DELIVERY

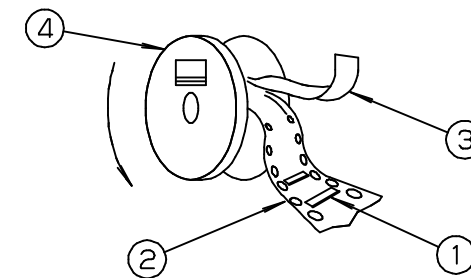

3. 引出し方向
USER DIRECTION OF FEED

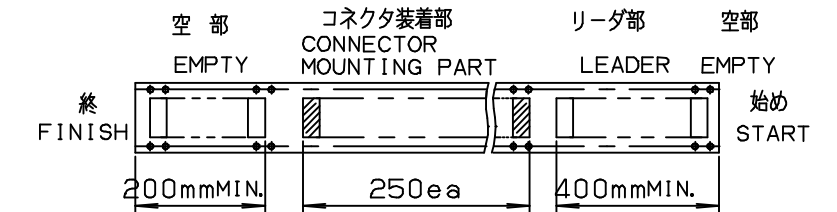

引出方向 →
USER DIRECTION OF FEED

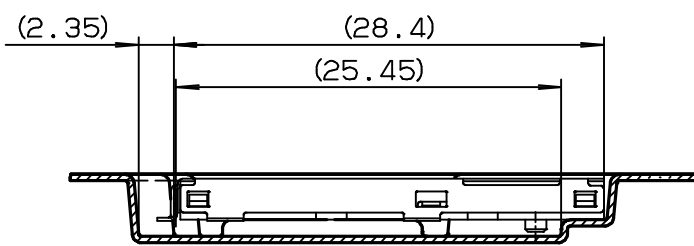

SECT. B-B

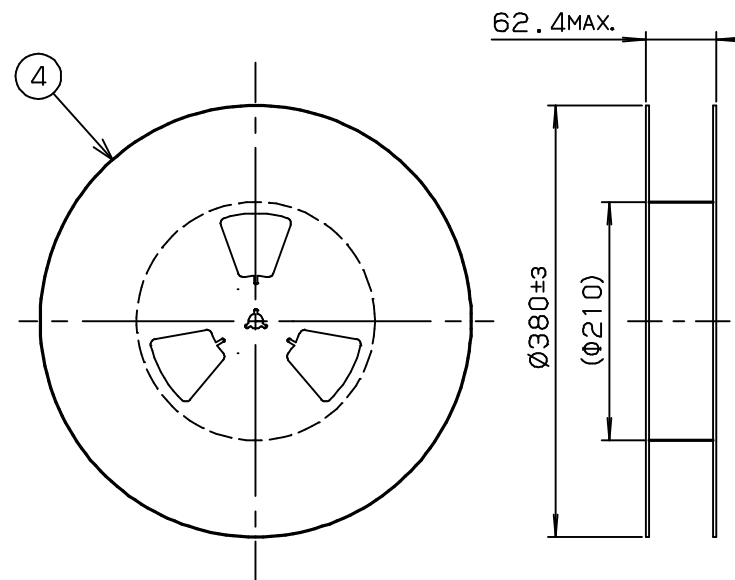

REEL DIMENSION

TOLERANCE / 一般公差 (S)		PRODUCT SPEC / 製品規格		A DCN-154 2-07-05					
X < 10	±0.2	UNIT	ANGLE	O EDN-651	6-16-04	A. SATOH	Y. SHIROYAMA	N. HAYASHI	
10 ≤ X < 30	±0.25	mm	3RD	NO.	EDN/DCN	DATE	ISSUE	CHECKED	APPROVED
30 ≤ X	±0.3	SCALE	DATE	PART NAME / 品名					
ANGLE / 角度	±3°	N/S	6-16-04	SERIES 5738 EMBOSS TAPE ASSY SD·I/O ASSY REVERSE TYPE H=2.7					
DRAWN	DESIGNED	CHECKED	APPROVED	PART NO. / 型番					
T. KOMATSU	A. SATO	Y. SHIROYAMA	N. HAYASHI	14 5738 009 210 859 +					
KYOCERA				DWG NO. / 図番		SHEET REV			
KYOCERA ELCO CORPORATION				BJS 5738037		1/1		A	