

REVISIONS			
REV.	DESCRIPTION	DATE	APPROVED
A	INITIAL RELEASE	03/02/17	D.N.

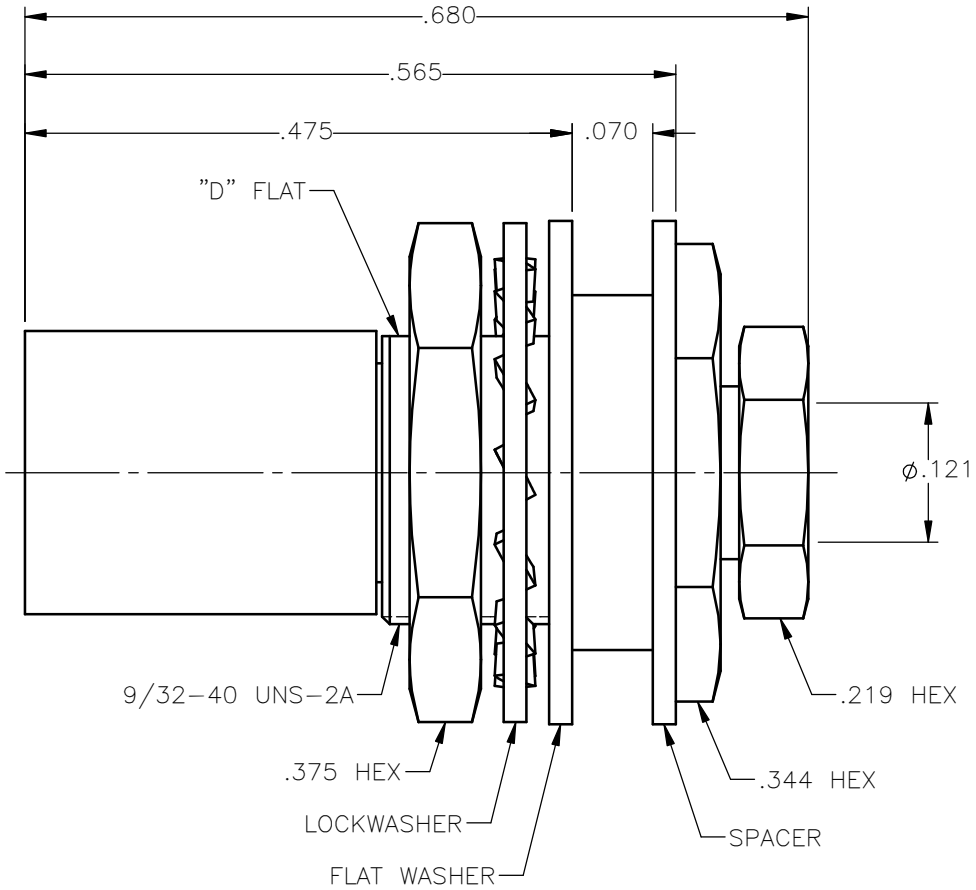

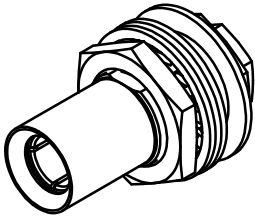

NOTES:

MATERIALS:

1. INSULATORS = VIRGIN WHITE TEFLON PER ASTM D1710, GRADE 1, TYPE I, CLASS "B".
2. CONTACT & SPRING = BERYLLIUM COPPER PER ASTM B196, ALLOY C17300, TEMPER TD04.
3. LOCKWASHER = PHOSPHOR BRONZE PER ASTM B139, COPPER ALLOY C53400, TEMPER H04.
4. ALL OTHER METAL PARTS = BRASS PER ASTM B16, ALLOY C36000, TEMPER H02.

FINISHES:

1. CONTACT = GOLD PLATE PER ASTM B488-11, TYPE II, 50 μ in MIN, GRADE C, OVER 100 TO 200 μ in STRESS FREE SULFAMATE NICKEL PER AMS-QQ-N-290.
2. SPRING = NICKEL PLATE PER AMS-QQ-N-290, CLASS 1, GRADE G, EXCEPT 100 TO 200 μ in THICK OVER 50 TO 100 μ in THICK COPPER PER AMS 2418.
3. ALL OTHER METAL PARTS = GOLD PLATE PER ASTM B488-11, TYPE II, 30 μ in MIN, GRADE C OVER 100 TO 200 μ in COPPER STRIKE PER AMS 2418.

UNLESS OTHERWISE SPECIFIED DIMENSIONS ARE IN INCHES TOLERANCES ON	DWN:	DATE		Property of Radiall			
	D.N.	03/02/17		This document cannot be reproduced or communicated to a third party without prior written permission of RADIALL.			
DECIMAL	ANGLE	CHKD:	DATE	SLB STRAIGHT FEMALE PLUG BULKHEAD FLOAT MOUNT CLAMP TYPE FOR .085 S/R & SIMILAR CABLES			
		N.D.	03/02/17				
		APVD:	DATE	SIZE	FSCM NO.	DWG NO.	REV
		J.M.	03/02/17	A	19505	3028-1541-610	A
REFERENCE:	MATERIALS & FINISHES:	SEE NOTES		SCALE	6:1		THIRD ANGLE PROJECTION
ORIGINATED: D.N. DATE: 03/02/17							SHEET 1 OF 1

3028-1541-610