



# MP2341

## High-Efficiency, 2A, 24V, 1MHz, Synchronous, Step-Down LED Driver in SOT583 Package

### DESCRIPTION

The MP2341 is a 24V, monolithic, synchronous, rectified, step-down, switch-mode white LED driver with built-in internal power MOSFETs and a synchronous rectifier switch. The MP2341 achieves up to 2A of continuous output current with excellent load and line regulation.

Peak current mode control operation provides fast transient response, easy loop design, and tight output regulation.

Fault condition protection includes cycle-by-cycle peak current limiting, output short circuit protection, open LED protection, and thermal shutdown.

The MP2341 requires a minimal number of readily available, standard external components, and is available in a space-saving SOT583 package.

### FEATURES

- Wide 4.2V to 24V Operating Input Range
- 125mΩ/75mΩ Low- $R_{DS(ON)}$  Internal Power MOSFETs
- High-Efficiency Synchronous Mode Operation
- Forced PWM Mode
- Fast Load Transient Response
- 1MHz Switching Frequency
- Internal Soft Start (SS)
- Analog Dimming by the DC Voltage through the EN/DIM Pin
- Analog Dimming by the PWM Signal through the PDIM Pin
- PWM Dimming by the PWM Signal through the EN/DIM Pin
- 50:1 Dimming Ratio via Analog Dimming
- 1000:1 Dimming Ratio via PWM Dimming
- Open LED Protection
- Over-Current Protection (OCP) and Hiccup Mode
- Over-Voltage Protection (OVP) with Auto-Recovery
- Thermal Shutdown
- 100mV Feedback (FB) Voltage
- Available in a SOT583 Package



Optimized Performance with  
MPS Inductor MPL-AL6060 Series

### APPLICATIONS

- Infrared LED Drivers
- General LED Drivers
- Flashlights
- Handheld Computer Backlighting

All MPS parts are lead-free, halogen-free, and adhere to the RoHS directive. For MPS green status, please visit the MPS website under Quality Assurance. "MPS", the MPS logo, and "Simple, Easy Solutions" are trademarks of Monolithic Power Systems, Inc. or its subsidiaries.

**TYPICAL APPLICATION**

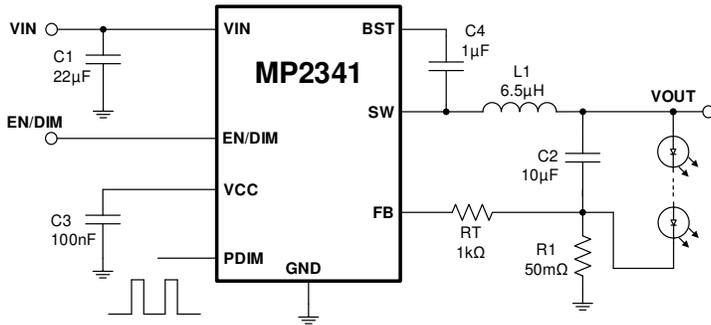

**Efficiency vs.  $V_{IN}$**

2 WLEDs in series,  $V_{OUT} = 5.9V$ ,  
 $L = 6.5\mu H$ ,  $I_{LED} = 2A$

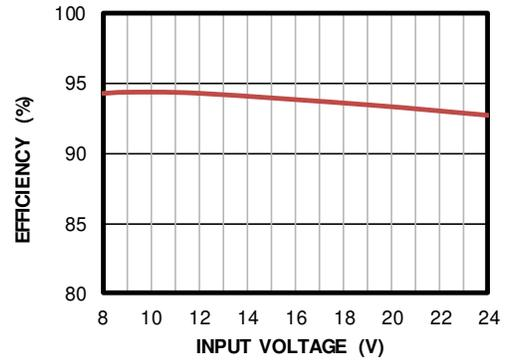

### ORDERING INFORMATION

Part Number*	Package	Top Marking	MSL Rating
MP2341GTL	SOT583	See Below	1

\*For Tape & Reel, add suffix -Z (e.g. MP2341GTL-Z).

### TOP MARKING

**BCEY**

**LLL**

BCE: Product code of MP2341GTL  
 Y: Year code  
 LLL: Lot number

### PACKAGE REFERENCE

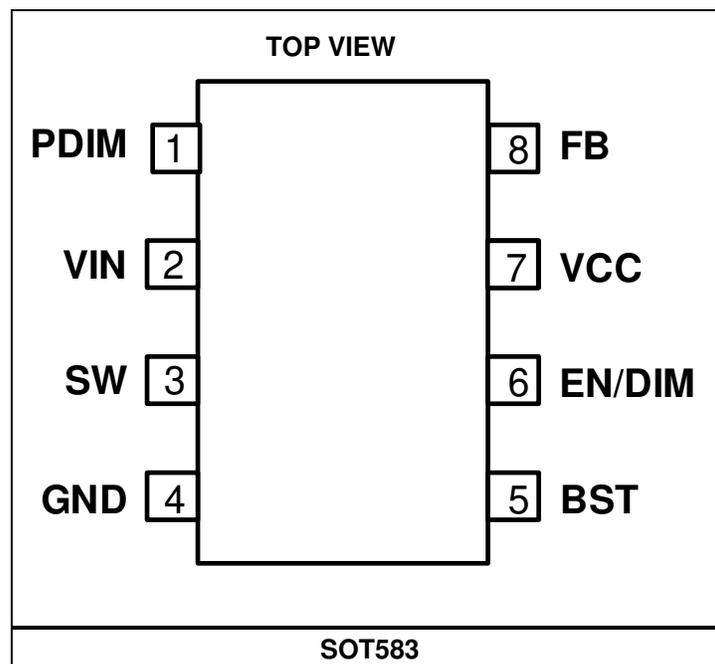

## PIN FUNCTIONS

Pin #	Name	Description
1	PDIM	<b>PWM signal input.</b> Apply a PWM signal on this pin for brightness control. It is recommended for the dimming frequency to be no lower than 10kHz.
2	VIN	<b>Supply voltage.</b> The MP2341 operates on a 4.2V to 24V input rail. A capacitor (C1) is required to decouple the input rail. Connect VIN to the input power supply positive terminal using a wide PCB trace.
3	SW	<b>Switch output.</b> Connect SW to the inductor using a wide PCB trace.
4	GND	<b>System ground.</b> This is the reference ground of the regulated output voltage. It requires extra care during PCB layout. Use copper traces and vias to connect to GND.
5	BST	<b>Bootstrap.</b> Connect a capacitor and a resistor between SW and BST to form a floating supply across the high-side (HS) switch driver. Use a 1µF BST capacitor.
6	EN/DIM	<b>On/off control input and dimming command input.</b> Leaving EN/DIM floating or applying a voltage higher than V <sub>EN_ON</sub> on this pin turns on the chip. For analog dimming, the EN/DIM voltage rises from V <sub>ADIM_MIN</sub> to V <sub>ADIM_MAX</sub> , and the output current changes from the minimum value to the full-scale LED current. To apply PWM dimming, apply 100Hz to 2kHz PWM signal with an amplitude above 1.6V to this pin.
7	VCC	<b>Internal bias supply.</b> Decouple with a 0.1µF to 0.22µF capacitor. Select a capacitor that does not exceed 0.22µF. The VCC capacitor should be placed as close as possible to the VCC and GND pins.
8	FB	<b>Current-sense feedback voltage.</b> FB's internal reference voltage is 0.1V.

### ABSOLUTE MAX RATINGS <sup>(1)</sup>

V <sub>IN</sub> .....	-0.3V to +26V
V <sub>SW</sub> .....	-0.3V (-6.5V for < +10ns) to +26V (28V for <10ns)
V <sub>BST</sub> .....	V <sub>SW</sub> + 5V
V <sub>EN</sub> .....	-0.3V to +5V
All other pins .....	-0.3V to +4V
Continuous power dissipation (T <sub>A</sub> = 25°C) <sup>(2)(4)</sup>	2.2W
Junction temperature .....	150°C
Lead temperature .....	260°C
Storage temperature .....	-65°C to +150°C

### ESD Ratings

Human body model (HBM) .....	±2000V
Charged device model (CDM) .....	±1250V

### Recommended Operating Conditions <sup>(3)</sup>

Supply voltage (V <sub>IN</sub> ) .....	4.2V to 24V
Output voltage (V <sub>OUT</sub> ) .....	0.8V to 0.9V <sub>IN</sub> or 20V max
Operating junction temp (T <sub>J</sub> ) .....	-40°C to +125°C

### Thermal Resistance

$\theta_{JA}$   $\theta_{JC}$

#### SOT583

EV2341-TL-00A <sup>(4)</sup> .....	55.....	21...°C/W
JESD51-7 <sup>(5)</sup> .....	130....	60...°C/W

#### Notes:

- Exceeding these ratings may damage the device.
- The max allowable power dissipation is a function of the max junction temperature T<sub>J</sub> (MAX), the junction-to-ambient thermal resistance  $\theta_{JA}$ , and the ambient temperature T<sub>A</sub>. The max allowable continuous power dissipation at any ambient temperature is calculated by P<sub>D</sub> (MAX) = (T<sub>J</sub> (MAX) - T<sub>A</sub>) /  $\theta_{JA}$ . Exceeding the max allowable power dissipation can cause excessive die temperature, and the regulator may go into thermal shutdown. Internal thermal shutdown circuitry protects the device from permanent damage.
- The device is not guaranteed to function outside of its operating conditions.
- Measured on EV2341-TL-00A, 2-layer PCB, 46mmx46mm.
- The value of  $\theta_{JA}$  given in this table is only valid for comparison with other packages and cannot be used for design purposes. These values were calculated in accordance with JESD51-7, and simulated on a specified JEDEC board. They do not represent the performance obtained in an actual application.

## ELECTRICAL CHARACTERISTICS

$V_{IN} = 12V$ ,  $T_J = -40^{\circ}C$  to  $+125^{\circ}C$  <sup>(6)</sup>, typical value is tested at  $T_J = 25^{\circ}C$ , unless otherwise noted.

Parameter	Symbol	Condition	Min	Typ	Max	Units
Shutdown supply current	$I_{IN}$	$V_{EN} = 0V$			25	$\mu A$
Quiescent supply current	$I_Q$	$V_{EN} = 2V$ , $V_{FB} = 1V$		500	650	$\mu A$
High-side (HS) switch on resistance	$HS_{RDS-ON}$	$V_{BST-SW} = 3.6V$		125		$m\Omega$
Low-side (LS) switch on resistance	$LS_{RDS-ON}$	$V_{CC} = 3.6V$		75		$m\Omega$
Switch leakage	$SW_{LKG}$	$V_{EN} = 0V$ , $V_{SW} = 12V$			1	$\mu A$
HS switch over-current protection (OCP) current limit	$I_{LIMIT\_HS\_OC}$		3.4	4		A
LS switch OCP current limit	$I_{LIMIT\_LS\_OC}$			3		A
LS current in continuous conduction mode (CCM)				-1.5		A
Oscillator frequency	$f_{SW}$	$V_{FB} = 80mV$	0.8	1	1.2	1MHz
Minimum on time <sup>(7)</sup>	$t_{ON\_MIN}$			60		ns
Minimum off time	$t_{OFF\_MIN}$			160		ns
FB voltage	$V_{REF}$	$EN = 2V$ , PDIM = high, $T_J = 25^{\circ}C$	97.5	100	102.5	mV
FB current	$I_{FB}$	$V_{FB} = 150mV$		10	100	nA
Burst mode allowable threshold	$V_{FB\_BURST\_TH}$			120	145	mV
Burst mode recovery hysteresis	$V_{FB\_BURST\_HYS}$			20		mV
Hiccup off time				2.4		ms
<b>Enable and Dimming</b>						
EN/DIM off threshold	$V_{EN\_OFF}$	$V_{EN/DIM}$ falling edge	0.27	0.33	0.37	V
EN/DIM on threshold	$V_{EN\_ON}$	$V_{EN/DIM}$ rising edge		0.76		V
Turn-on delay time <sup>(7)</sup>	$t_{ON\_DELAY}$	From EN high to when $I_{LED}$ starts ramp up		750		$\mu s$
Turn-off delay time	$t_{OFF\_DELAY}$			16		ms
EN/DIM pull-up current	$I_{EN/DIM}$	$V_{EN} = 0V$	4	9	14	$\mu A$
Maximum analog dimming threshold	$V_{ADIM\_MAX}$	Theoretically, $V_{FB} = 100mV$	1.31	1.44	1.57	V
Minimum analog dimming threshold	$V_{ADIM\_MIN}$	$V_{FB} = 5mV$ , $T_J = 25^{\circ}C$	0.66	0.74	0.82	V
<b>PDIM</b>						
PDIM input low threshold	$V_{PDIM\_LO}$	$V_{PWM}$ falling			0.4	V
PDIM input high threshold	$V_{PDIM\_HI}$	$V_{PWM}$ rising	1.5			V

**ELECTRICAL CHARACTERISTICS (continued)**

$V_{IN} = 12V$ ,  $T_J = -40^{\circ}C$  to  $+125^{\circ}C$  <sup>(6)</sup>, typical value is tested at  $T_J = 25^{\circ}C$ , unless otherwise noted.

Parameter	Symbol	Condition	Min	Typ	Max	Units
PDIM pull-up current	$I_{PDIM\_UP}$			1.7		$\mu A$
$V_{IN}$ under-voltage lockout (UVLO) rising threshold	$INUV_{VTH}$		3.7	4	4.2	V
$V_{IN}$ UVLO threshold hysteresis	$INUV_{HYS}$			350		mV
Soft-start (SS) time	$t_{SS}$	LED load = 5.9V/2A, $t_{SS}$ from 0V to 5.9V	0.4	0.56	0.72	ms
VCC voltage	$V_{CC}$			3.6		V
VCC load regulation		$I_{CC} = 5mA$		3		%
Thermal shutdown <sup>(7)</sup>				150		$^{\circ}C$
Thermal hysteresis <sup>(7)</sup>				20		$^{\circ}C$

**Notes:**

- 6) Not tested in production. Guaranteed by over-temperature correlation.
- 7) Guaranteed by design and engineering sample characterization.

## TYPICAL PERFORMANCE CHARACTERISTICS

$V_{IN} = 12V$ , 2 WLEDs in series,  $V_{OUT} = 5.9V$ ,  $L = 6.5\mu H$ ,  $T_A = 25^\circ C$ , unless otherwise noted.

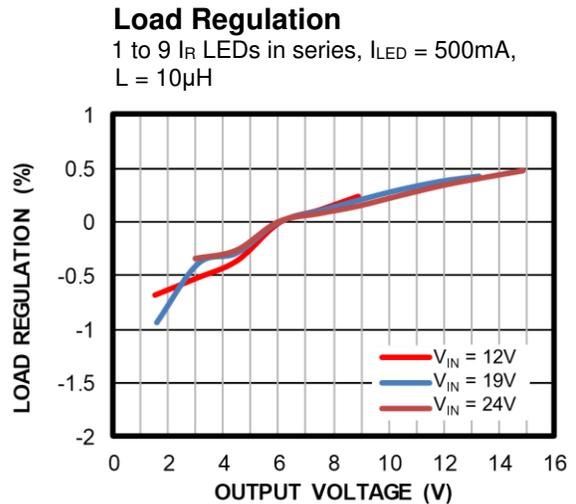
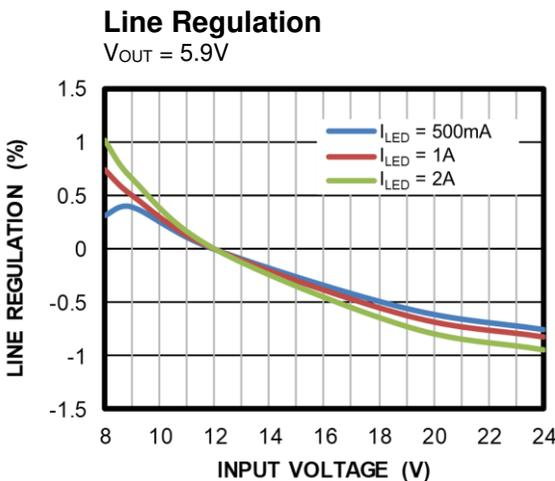
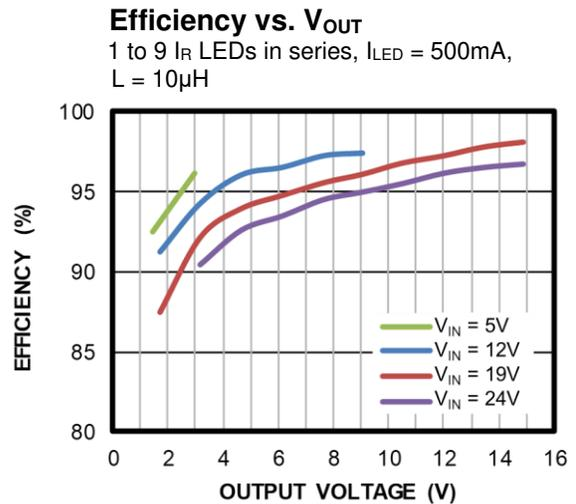
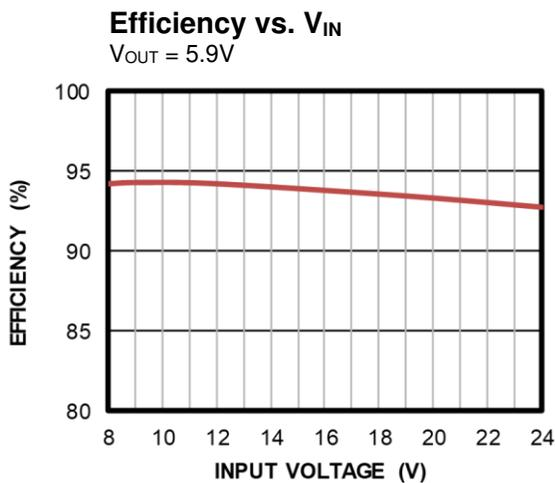
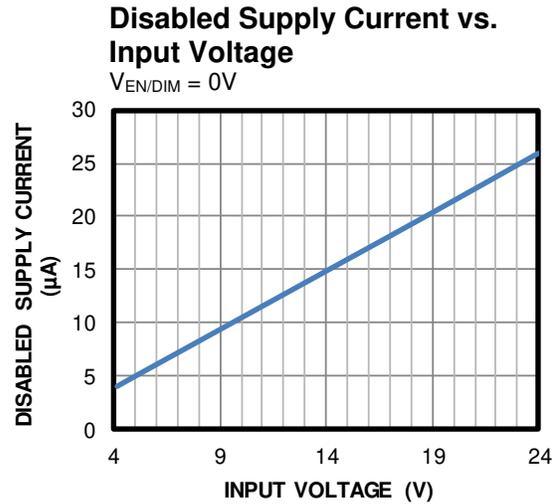
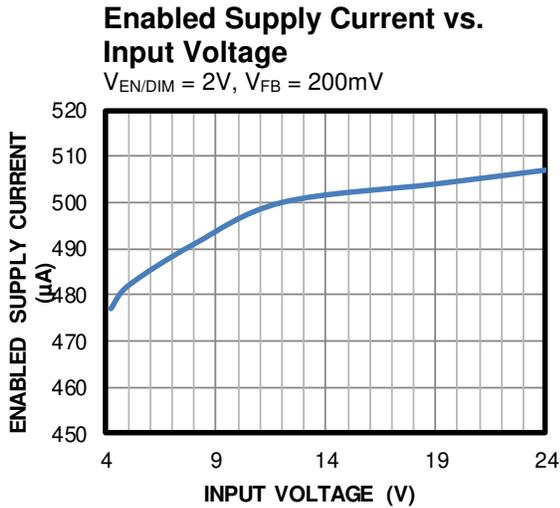

**TYPICAL PERFORMANCE CHARACTERISTICS (continued)**

$V_{IN} = 12V$ , 2 WLEDs in series,  $V_{OUT} = 5.9V$ ,  $L = 6.5\mu H$ ,  $T_A = 25^\circ C$ , unless otherwise noted.

**Analog Dimming Curve**  
Ramp up/down EN/DIM voltage

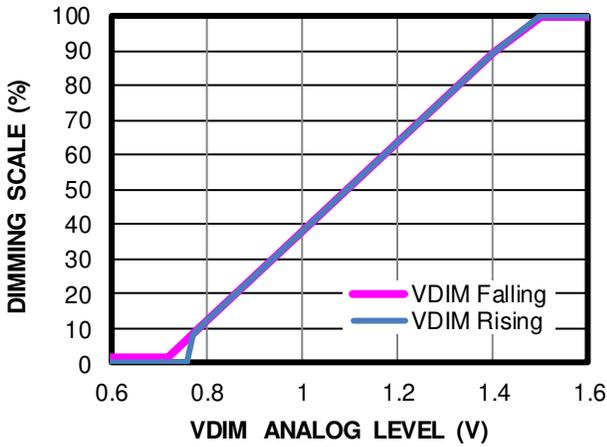

**Analog Dimming Curve**  
PDIM frequency = 20kHz

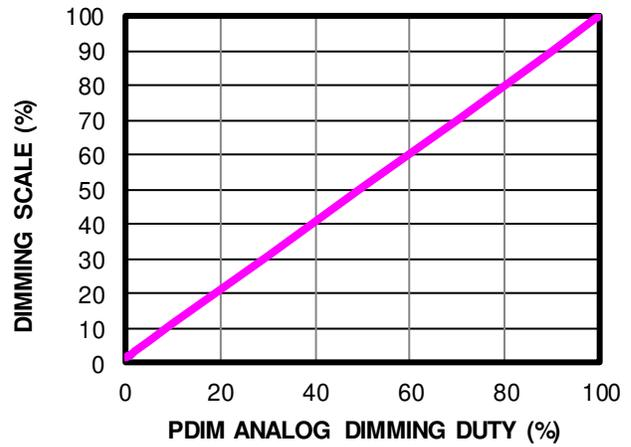

**PWM Dimming Curve**  
EN/DIM frequency = 200Hz



**Thermal Test**  
 $V_{OUT} = 5.9V$

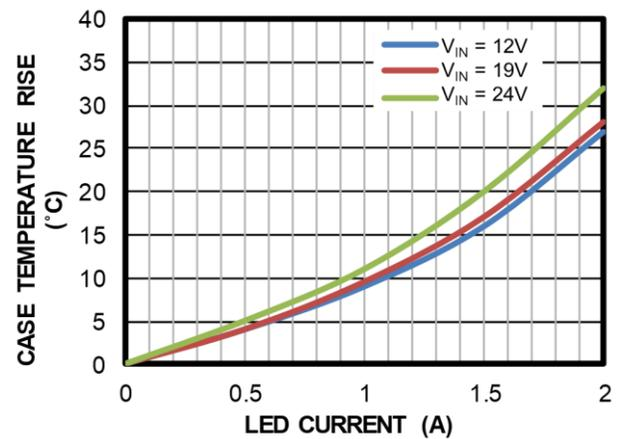

**TYPICAL PERFORMANCE CHARACTERISTICS (continued)**

$V_{IN} = 12V$ , 2 WLEDs in series,  $V_{OUT} = 5.9V$ ,  $L = 6.5\mu H$ ,  $T_A = 25^\circ C$ , unless otherwise noted.

**Steady State**

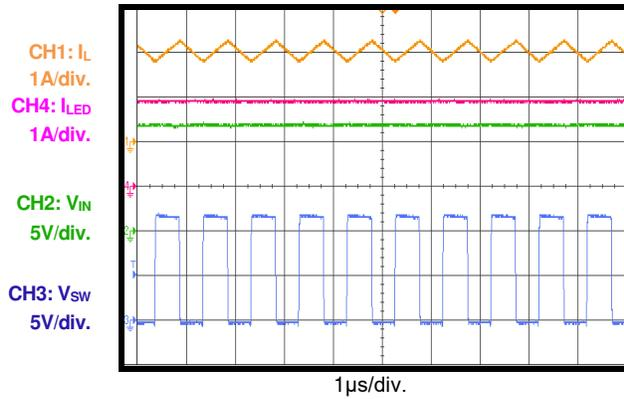

**VIN Start-Up**

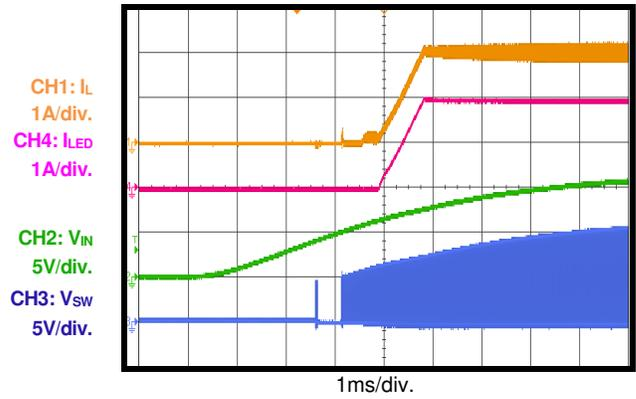

**VIN Shutdown**

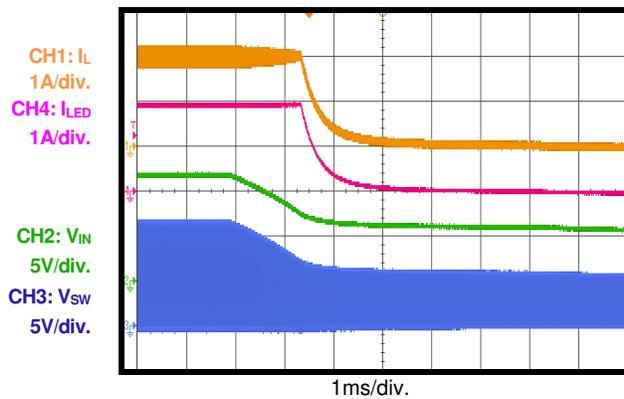

**EN Start-Up**

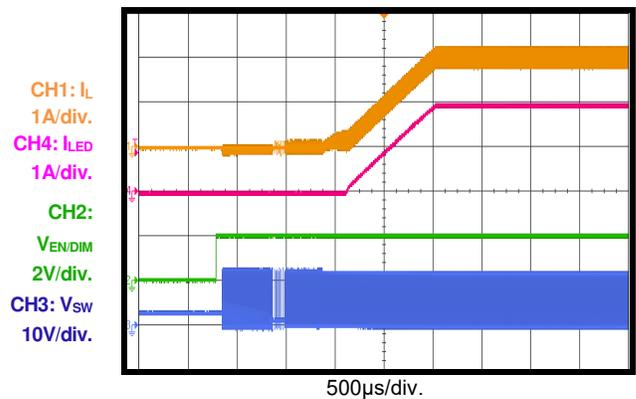

**EN Shutdown**

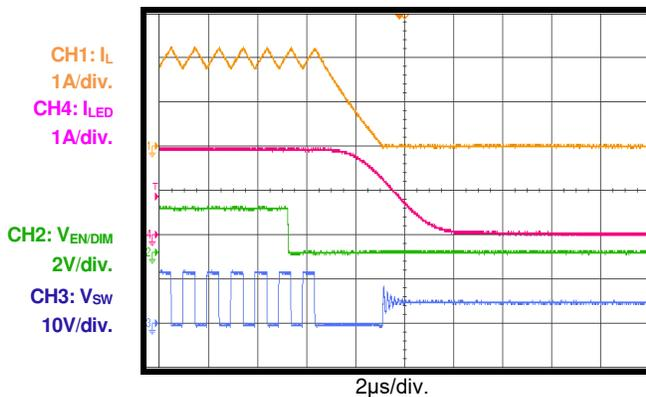

**Minimum Analog Dimming**

$V_{PDIM} = 2V$ , frequency = 20kHz,  
duty = 0.63%,  $V_{FB} = 1mV$

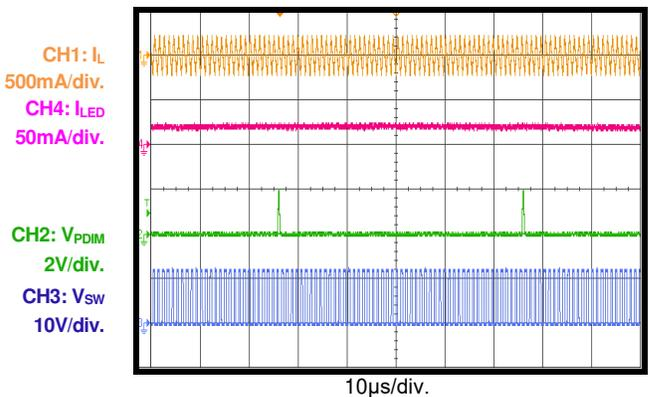

**TYPICAL PERFORMANCE CHARACTERISTICS (continued)**

$V_{IN} = 12V$ , 2 WLEDs in series,  $V_{OUT} = 5.9V$ ,  $L = 6.5\mu H$ ,  $T_A = 25^\circ C$ , unless otherwise noted.

**PWM Dimming**

$V_{EN}/DIM = 2V$ , frequency = 1kHz, duty = 50%

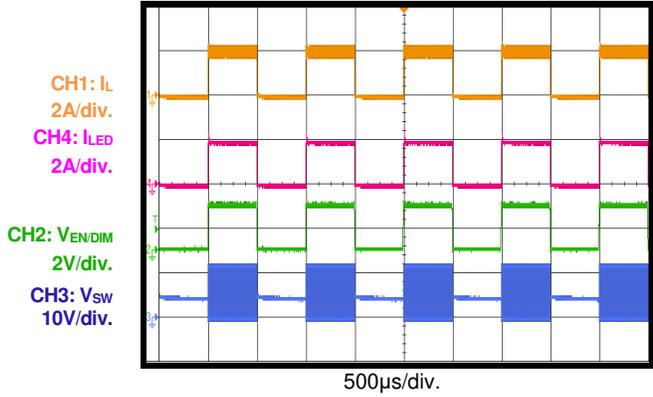

**Open LED Protection**

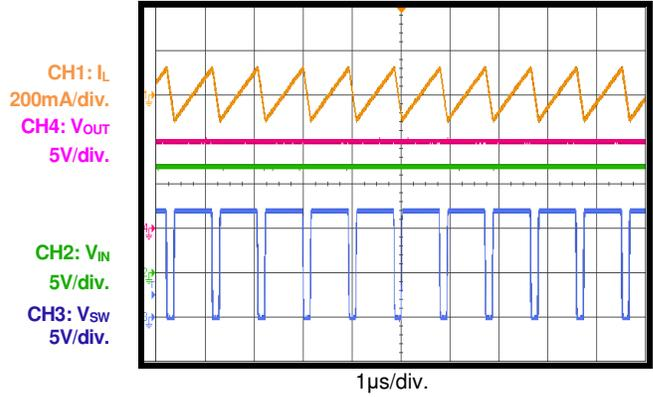

**LED+ to LED- Short Protection**

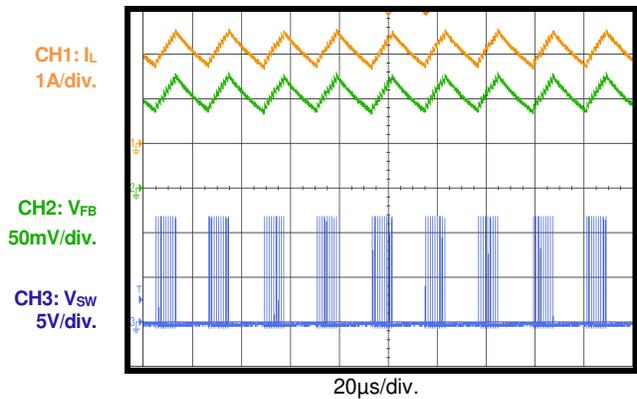

**LED+ to GND Short Protection**

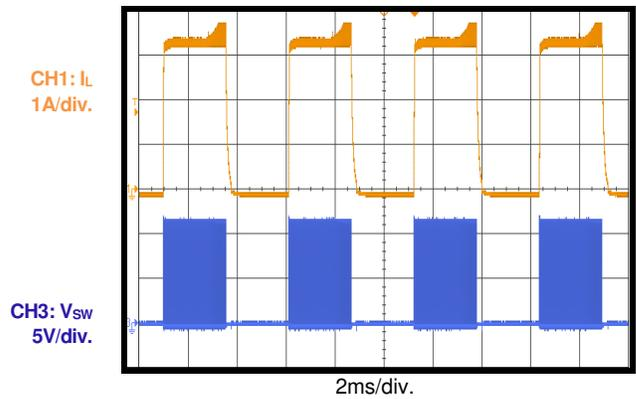

## FUNCTIONAL BLOCK DIAGRAM

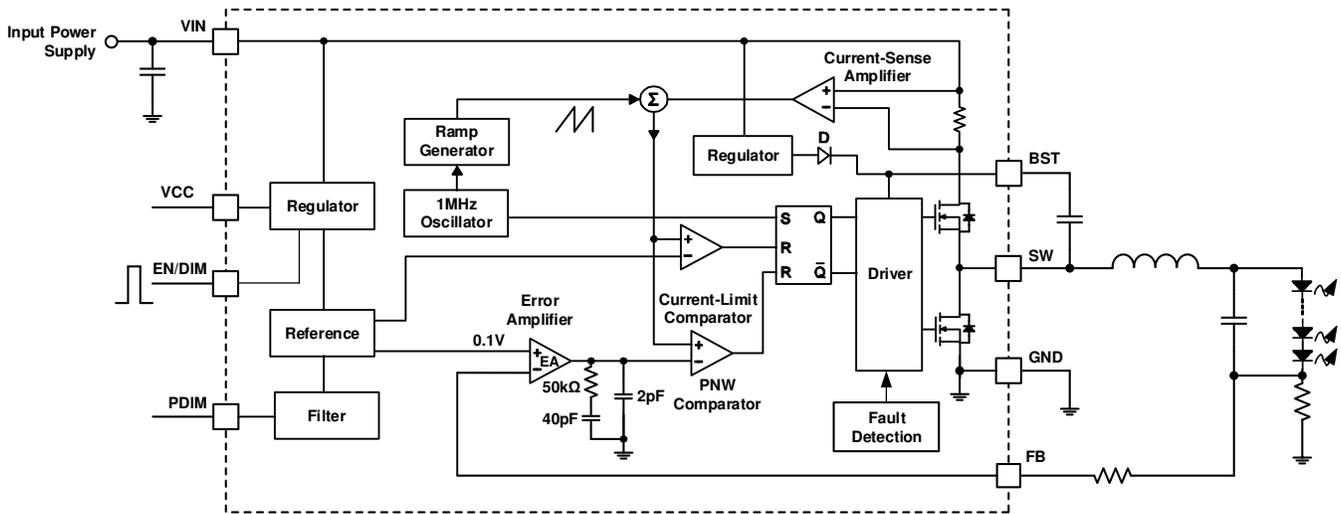

Figure 1: Functional Block Diagram

## OPERATION

The MP2341 is a high-frequency, synchronous, rectified, step-down, switch-mode LED driver with built-in internal power MOSFETs and a synchronous rectifier switch. The MP2341 offers a high-performance solution by achieving up to 2A of continuous output LED current, with excellent load and line regulation over a wide input voltage range.

The MP2341 operates in peak current control mode at a fixed 1MHz frequency to regulate the output current. An internal clock initiates the beginning of every new switching cycle. The integrated high-side power MOSFET (HS-FET) turns on, and the inductor current rises linearly to provide energy to the load. The HS-FET remains on until its current reaches the COMP level value — the output of the internal error amplifier (EA). The error amplifier’s output voltage depends on the difference between the output feedback (FB) and the internal high-precision reference. The result of these values determines the amount of energy transferred to the load.

The HS-FET remains off until the next clock cycle begins. When the HS-FET turns off, the low-side MOSFET (LS-FET) turns on and the inductor current flows through the LS-FET. A dead time is inserted to prevent shoot-through by prohibiting the HS-FET and the LS-FET from turning on at the same time.

When the duty cycle of one switching period reaches 84% of the max duty cycle, the current in the HS-FET does not reach the COMP-set current value, and the HS-FET is forced to turn off.

### Under-Voltage Lockout (UVLO) and IC Start-Up and Shutdown Procedure

Under-voltage lockout (UVLO) prevents the MP2341 from operating at an insufficient supply voltage. The MP2341’s UVLO comparator monitors the output voltage of the internal regulator, which is supplied from  $V_{IN}$ .

The MP2341 starts up if both  $V_{IN}$  and EN/DIM exceed their respective thresholds. First the reference block starts generating stable reference voltages and currents, and then the internal regulator is enabled. The internal regulator provides a stable supply for the remaining circuitries. Three events can shut

down the IC: EN/DIM remaining low for longer than  $t_{OFF\_DELAY}$ ,  $V_{IN}$  going below UVLO, and thermal shutdown. In the shutdown procedure, the signaling path is blocked first to avoid any fault triggering. Then the COMP voltage ( $V_{COMP}$ ) and the internal supply rail are pulled down.

### Error Amplifier (EA)

The internal low offset error amplifier (EA) compares the FB voltage ( $V_{FB}$ ) with the internal 100mV reference and outputs a COMP voltage ( $V_{COMP}$ ), which is inside the IC.  $V_{COMP}$  is used to control the HS-FET peak current and regulate the output current.

### Internal Soft Start (SS)

Soft start (SS) prevents the converter output current from overshooting during start-up. When the MP2341 starts up, the internal circuitry generates an SS voltage ( $V_{SS}$ ) that ramps up from 0V. The SS period ( $t_{ss}$ ) lasts until the voltage on the SS capacitor exceeds the 0.1V reference voltage. At this point, the reference voltage ( $V_{REF}$ ) takes over.

### Floating Driver and Bootstrap (BST) Charging

An external bootstrap (BST) capacitor powers the HS floating power MOSFET. This floating driver has its own UVLO protection. The UVLO rising threshold is 2.5V, with a hysteresis of 160mV. The BST capacitor voltage is regulated internally. During normal operation, a 3.3V BST voltage is maintained between BST and SW.

### Enable Control (EN/DIM)

The EN/DIM control pin turns the regulator on and off, and dims the output LED current. To turn on the MP2341, leave EN/DIM floating or drive EN/DIM high. The MP2341 turns off after the IC is pulled low for  $t_{OFF\_DELAY}$  (typically 16ms). Figure 2 shows the control logic for EN/DIM.

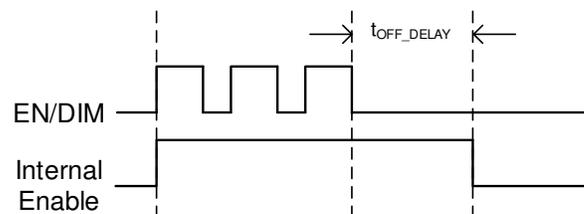

Figure 2: EN/DIM Timing Sequence

### Analog Dimming

The MP2341 provides two analog dimming methods: Apply a DC signal on the EN/DIM pin or send a PWM signal on the PDIM pin.

When the voltage on EN/DIM is below  $V_{ADIM\_MIN}$ , the LED current is regulated to its minimum scale. When the voltage on EN/DIM is between  $V_{ADIM\_MIN}$  and  $V_{ADIM\_MAX}$ , the LED current changes from its minimum scale to its full scale. If the voltage on EN/DIM exceeds  $V_{ADIM\_MAX}$ , the max LED current is regulated.

Figure 3 shows the analog dimming curve. Due to the EN/DIM on/off threshold hysteresis, at the  $V_{EN\_DIM}$  falling edge, the chip remains at the minimum LED current until  $V_{EN\_DIM}$  falls below  $V_{EN\_OFF}$ . The dimming curve is the same in the linear dimming range.

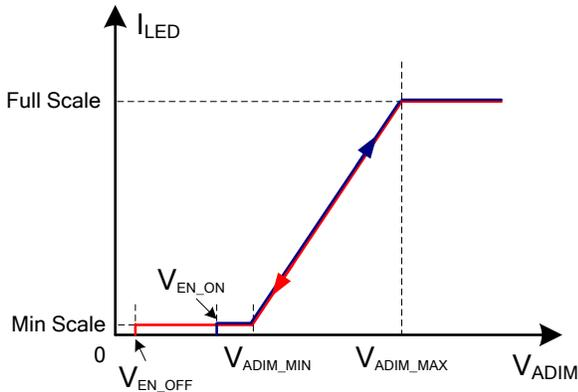

**Figure 3: Analog Dimming Curve by EN/DIM**

When a PWM signal is applied to the PDIM pin and the EN/DIM voltage exceeds  $V_{ADIM\_MAX}$ , the IC dims the LED current with analog mode and the LED current amplitude is equal to  $I_{SET} \times DUTY_{PDIM}$ . ( $I_{SET}$  is the LED current set by the resistor connected to the FB pin, and  $DUTY_{PDIM}$  is the duty cycle of the PWM signal on the PDIM pin.) Analog dimming helps reduce the LED power loss and avoid audible noise. It is recommended to set the dimming frequency above 10kHz.

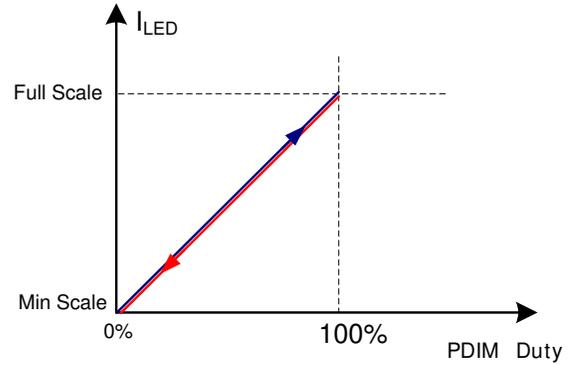

**Figure 4: Analog Dimming Curve by PDIM**

If the EN/DIM voltage is between  $V_{ADIM\_MIN}$  and  $V_{ADIM\_MAX}$ , the PWM signal is also applied to the PDIM pin, then the LED current is determined by both effect. In this case, the LED current amplitude is equal to  $I_{SET1} \times DUTY_{PDIM}$ .  $I_{SET1}$  is the LED current set by both the resistor connected to the FB pin and the EN/DIM voltage.

### PWM Dimming

Apply a PWM signal on EN/DIM to implement PWM dimming mode. To achieve good dimming linearity, the dimming frequency's recommended range is 100Hz to 2kHz. The digital signal's amplitude must be above 1.57V.

### Open LED

If the LED is open without an FB signal, the MP2341 works at the max duty cycle and the output voltage rises close to the input voltage.

### LED Short-Circuit Protection (SCP)

The MP2341 integrates LED short-circuit protection (SCP) circuitry. Several features protect the MP2341 from damage when an LED short circuit occurs.

The MP2341 features a cycle-by-cycle current limit to restrict the max inductor current. A protection mechanism monitors the FB level through an internal R-C filter. Once it reaches  $V_{FB\_BURST\_TH}$ , the IC stops switching until the FB level drops to a lower value; then the system works in burst mode.

In the worst-case scenario, the LED is shorted to ground. If the cycle-by-cycle current limit function cannot clamp the current overshoot sufficiently, the HS-FET and LS-FET currents are also monitored by the over-current detector inside the IC. If the HS current exceeds the

OCP current threshold (typically 4A) in every cycle with a 140 $\mu$ s counter, the IC turns off the HS-FET and LS-FET for 2.4ms, then restarts. During this period,  $V_{COMP}$  is pulled down to GND for a SS fault condition restart.

### **Thermal Shutdown**

Thermal shutdown is implemented to prevent the MP2341 from operating at exceedingly high temperatures. If the silicon die temperature exceeds 150°C, OTP shuts down the entire IC. When the temperature returns below its lower threshold (typically 130°C), the MP2341 restarts and resumes normal operation.

## APPLICATION INFORMATION

### Setting the LED Current

The current-sense resistor is inserted between the anode of LED and GND. The current-sense resistor value can be calculated with Equation (1):

$$R_s = \frac{0.1V}{I_{LED}} \quad (1)$$

For a 2A LED current output, choose  $R_s = 50m\Omega$ .

### Selecting the Inductor

 **Optimized Performance with MPS Inductor**

For most applications, an inductance value below  $22\mu H$ , with a nominal DC current rating at least 25% higher than the max load current, is recommended. For the highest efficiency, the inductor's DC resistance should be less than  $100m\Omega$ . The required inductance value for most designs can be calculated with Equation (2):

$$L = \frac{V_{OUT} \times (V_{IN} - V_{OUT})}{V_{IN} \times \Delta I_L \times f_{SW}} \quad (2)$$

Where  $\Delta I_L$  is the inductor ripple current.

Choose the inductor ripple current to be 30% of the max load current. The max inductor peak current can be calculated with Equation (3):

$$I_{L(MAX)} = I_{LED} + \frac{\Delta I_L}{2} \quad (3)$$

MPS inductors are optimized and tested for use with our complete line of integrated circuits.

Table 1 lists our power inductor recommendations. Select a part number based on your design requirements.

**Table 1: Power Inductor Selection**

Part Number	Inductance Value	Manufacturer
MPL-AL family	4.7 $\mu H$ to 15 $\mu H$	MPS
MPL-AL6060-5R6	5.6 $\mu H$	MPS
MPL-AL6060-6R8	6.8 $\mu H$	MPS
MPL-AL6060-100	10 $\mu H$	MPS
MPL-AL6060-150	15 $\mu H$	MPS

Visit [MonolithicPower.com](http://MonolithicPower.com) under Products > Inductors for more information.

### Selecting the Input Capacitor

The input capacitor reduces surge current drawn from the input supply and switching noise from the device. The input capacitor impedance at the switching frequency should be less than the source impedance, to prevent the high-frequency switching current from passing through the input. Ceramic capacitors with X5R or X7R dielectrics are highly recommended due to their low ESR and small temperature coefficients. For most applications, a  $22\mu F$  capacitor is sufficient.

### Selecting the Output Capacitor

The output capacitor keeps the output current ripple small and ensures FB loop stability. The output capacitor impedance should be low at the switching frequency. Ceramic capacitors with X5R or X7R dielectrics are recommended for their low ESR characteristics. For most applications, a  $10\mu F$  ceramic capacitor is sufficient.

### Design Example

Table 2 shows a design example following the application guidelines for the specifications.

**Table 2: Design Example**

$V_{IN}$	8V to 24V
$V_{OUT}$	Two WLEDs in series
$I_{LED}$	2A

Figure 6 shows the detailed application schematic. For the typical performance and circuit waveforms, see the Typical Performance Characteristics section on page 7. For more device applications, refer to the related evaluation board datasheet.

## PCB Layout Guidelines <sup>(8)</sup>

Efficient PCB layout is critical for stable operation and good EMI performance. For the best results, refer to Figure 5 and follow the guidelines below:

1. Place the input capacitor as close to VIN and GND as possible.
2. Keep the FB trace as short as possible. If the FB length is too long due to component size, an RT resistor is required.
3. Keep the switching noise trace as short as possible.
4. Keep the switch node traces, such as the SW node and BST nodes, short and away from the FB network.

### Note:

- 8) The recommended PCB layout is based on Figure 6.

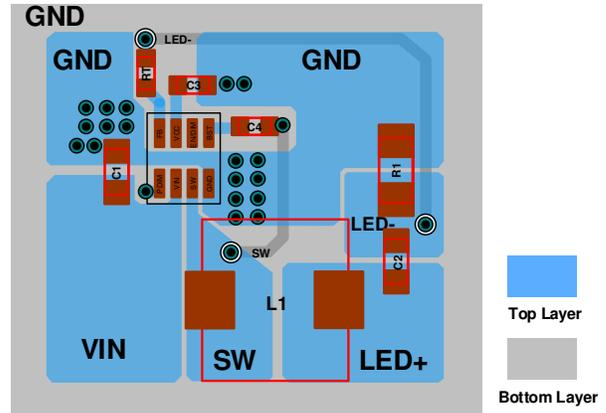
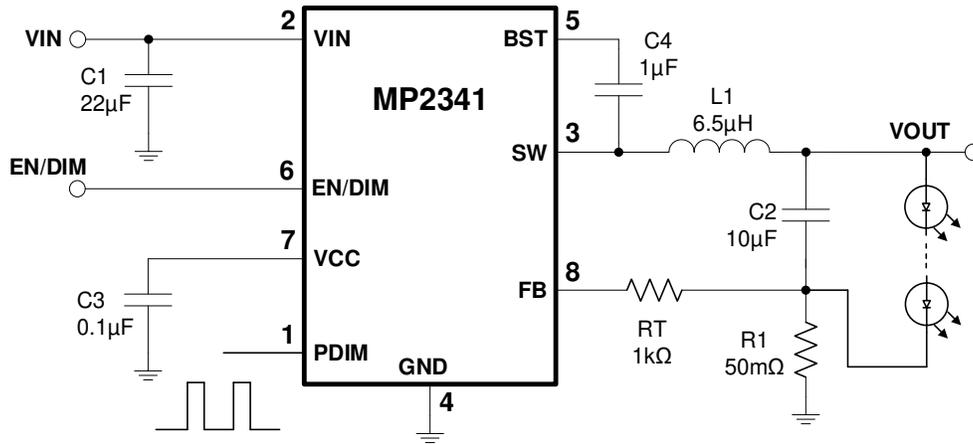

Figure 5: Recommended PCB Layout

**TYPICAL APPLICATION CIRCUIT**



**Figure 6: Typical Buck Converter Application,  $V_{IN} = 8V$  to  $24V$ , 2 WLEDs in Series,  $V_{OUT} = 5.9V$ ,  $I_{LED} = 2A$**

**PACKAGE INFORMATION**

**SOT583**

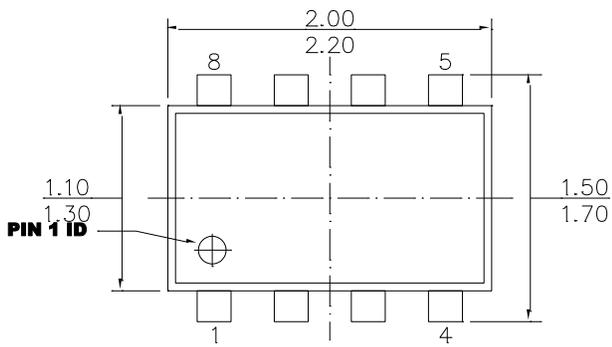

**TOP VIEW**

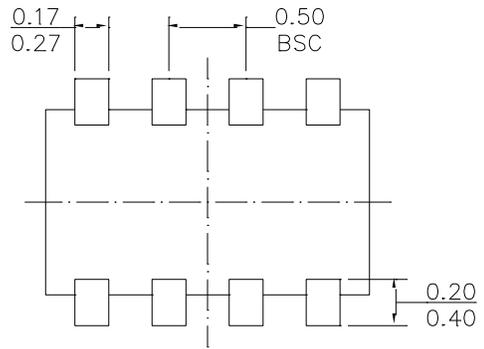

**BOTTOM VIEW**

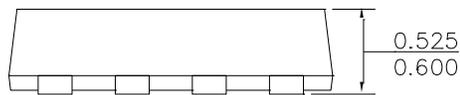

**FRONT VIEW**

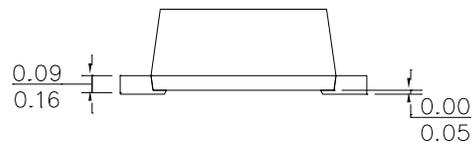

**SIDE VIEW**

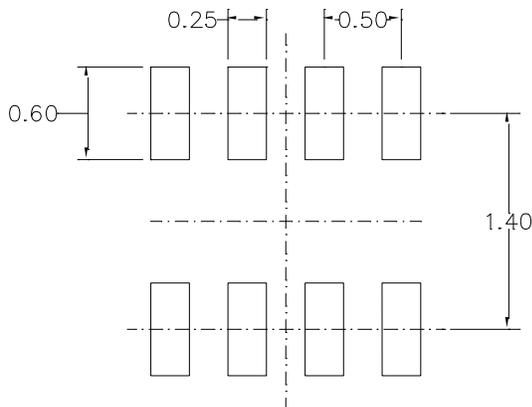

**RECOMMENDED LAND PATTERN**

**NOTE:**

- 1) ALL DIMENSIONS ARE IN MILLIMETERS.
- 2) PACKAGE WIDTH DOES NOT INCLUDE INTERLEAD FLASH OR PROTRUSION.
- 3) LEAD COPLANARITY (BOTTOM OF LEADS AFTER FORMING) SHALL BE 0.10 MILLIMETERS MAX.
- 4) DRAWING IS NOT TO SCALE.

**CARRIER INFORMATION**

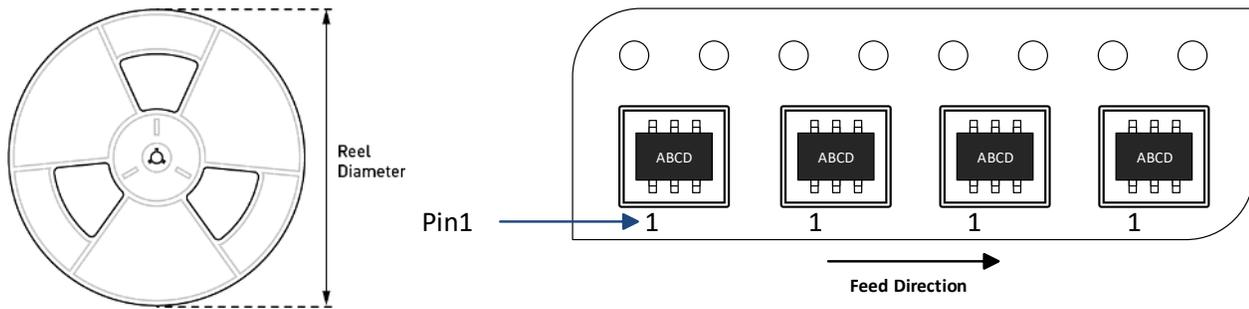

Part Number	Package Description	Quantity/Reel	Quantity/Tube	Quantity/Tray	Reel Diameter	Carrier Tape Width	Carrier Tape Pitch
MP2341GTL-Z	SOT583	5000	N/A	N/A	7in	8mm	4mm

## Revision History

Revision #	Revision Date	Description	Pages Updated
1.0	10/29/2020	Initial Release	-

**NOTICE:** The information in this document is subject to change without notice. Users should warrant and guarantee that third-party Intellectual Property rights are not infringed upon when integrating MPS products into any application. MPS will not assume any legal responsibility for any said applications.