

NOTES:

1. RECOMMENDED P.C.B. THICKNESS 1.60 MM
2. HOUSING MAT'L: NYLON 66, 25% GLASS REINFORCED, COLOR: SEE TABLE
3. CONTACTS: PHOS BRONZE ALLOY UNS-C51000, Ø 0.460 ROUND WIRE, PLATING SEE TABLE.
- ④ METAL SHELL MATERIAL: COPPER ALLOY, 0.20MM THICK. FINISH: FOR 74543-XXXX TIN-LEAD 100u" THICK FOR 74543-XXXXLF PURE TIN 80u" THICK FOR 74543-XXXXNLF 1.27µm/50µ" MINIMUM NICKEL PLATING WITH TIN DIPPED BY MANUAL ON THE SOLDER TAIL . SEE THE DETAIL A
5. PACKAGING PER GES-14-361, USING TUBE
6. IF LF P/N THE PRODUCT MEETS EUROPEAN UNION DIRECTIVES AND OTHER COUNTRY REGULATIONS AS DESCRIBED IN GS-22-008
7. IF LF P/N THE HOUSING WILL WITHSTAND EXPOSURE TO 260°C PEAK TEMPERATURE FOR 10 SECONDS IN A WAVE SOLDER APPLICATION WITH A 1.60mm MINIMUM THICK CIRCUIT BOARD
8. IF LF P/N PACKAGING MEETS GS-14-920 SPECIFICATION
- ⑨ EQUIVALENT THICKNESS Au AND GXT PLATING HAVE SAME FUNCTION AND THEY ARE ALTERNATIVE BY THE CUSTOEMR.

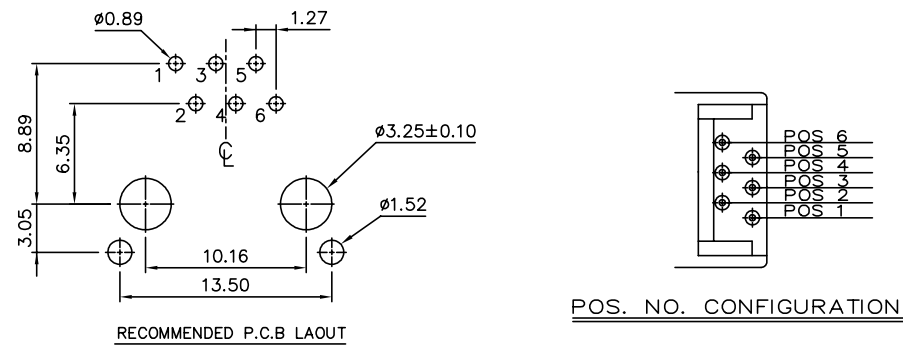
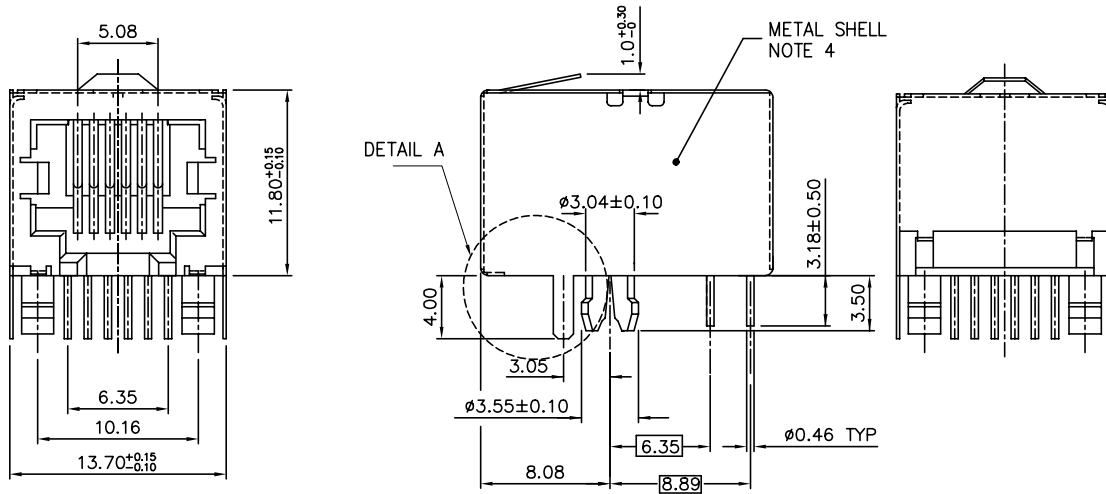

PRODUCT NO	NUMBER OF POS.	LOADED POSITION	HSG COLOR	PLATING
74543-3661	6	ALL POS.	BLACK	5u" Au + high performance lubricant
74543-5661		ALL POS.		50 u" GXT
74543-0641		2,3,4,5		5u" Au + high performance lubricant
74543-0661		ALL POS.		5u" Au + high performance lubricant
74543-0661LF		ALL POS.		5u" Au + high performance lubricant
74543-3661LF		ALL POS.		5u" Au + high performance lubricant
74543-5661LF		ALL POS.		50 u" GXT
74543-0641LF		2,3,4,5		5u" Au + high performance lubricant
74543-3661NLF		ALL POS.		5u" Au + high performance lubricant
74543-5661NLF		ALL POS.		50 u" GXT
74543-0641NLF		2,3,4,5		5u" Au + high performance lubricant

mat'l. code	surface ISO1302 ✓	tolerance ISO1101 ISO406	projection	product family MOD JACK
l trechn nodr	date	tolerances unless otherwise specified	mm	title
D N04-0125	YS 12/15/04	0.X±0.3	mm	LOW PROFILE PCB III 6 POS
E N06-0305	WG 12/12/06	0.XX±0.15	scale 2.0	MOD JACK, FULLY SHIELDED
F N07-0215	WG 09/07/07	0.XXX±0.05		
G N08-0052	SH MM 03/25/08	dr CATHY LIN 01/16/98		dwg no
H ELX-N-010705	SH MM 3/14/12	engr TONY CHIEN 01/16/98		sheet 1 of 1
		chr TONY CHIEN 01/16/98		size A4
		appd JENN TSAO 01/16/98		type Product Customer Drawing
sheet index	revision sheet 1			