

DC/DC Converter Control Circuits

General Description

The RT34063A Series is a monolithic control circuit containing the primary functions required for DC/DC converters.

These devices consist of an internal temperature compensated reference, comparator, controlled duty cycle oscillator with an active current limit circuit, driver and high current output switch.

This series was specially designed to be incorporated in step-down and step-up and Voltage-inverting applications with a minimum number of external components.

Ordering Information

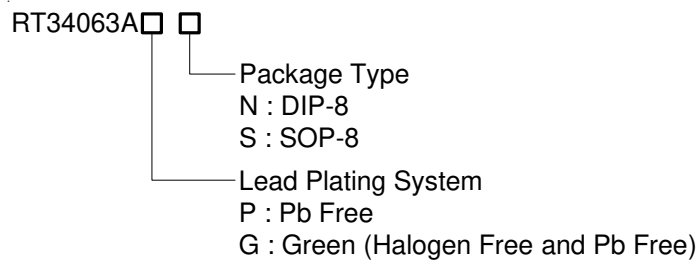

Note :

Richtek products are :

- ▶ RoHS compliant and compatible with the current requirements of IPC/JEDEC J-STD-020.
- ▶ Suitable for use in SnPb or Pb-free soldering processes.

Features

- Operation from 3.0V to 30V Input
- Low Standby Current
- Current Limiting
- Internal Switch Current to 1.5A
- Output Voltage Adjustable
- Frequency Operation to 100kHz
- Precision 2% Reference
- RoHS Compliant and 100% Lead (Pb)-Free

Applications

- Saver for Cellular Phones
- DC/DC Converter Module

Pin Configurations

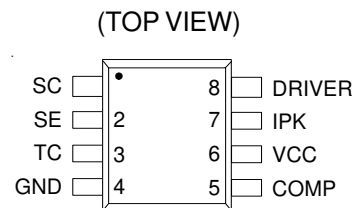

DIP-8 / SOP-8

Functional Pin Description

Pin Name	Pin Function
SC	1.5A Switch Collector.
SE	Darlington Switch Emitter.
TC	Oscillator Timing Capacitor.
GND	Power GND.
COMP	Feedback Comparator Inverting Input.
VCC	Power Supply Input.
IPK	High side Current Sense Input $V_{CC} - V_{IPK} = 330mV$.
DRIVER	Driver Collector.

Function Block Diagram

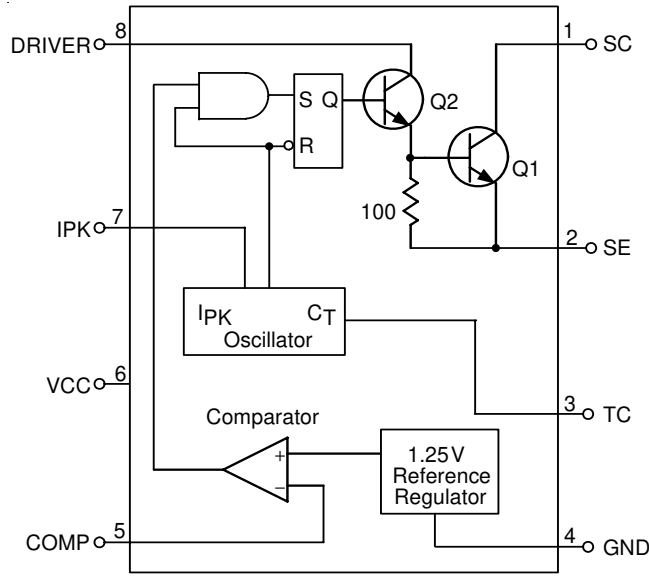

Typical Application Circuit

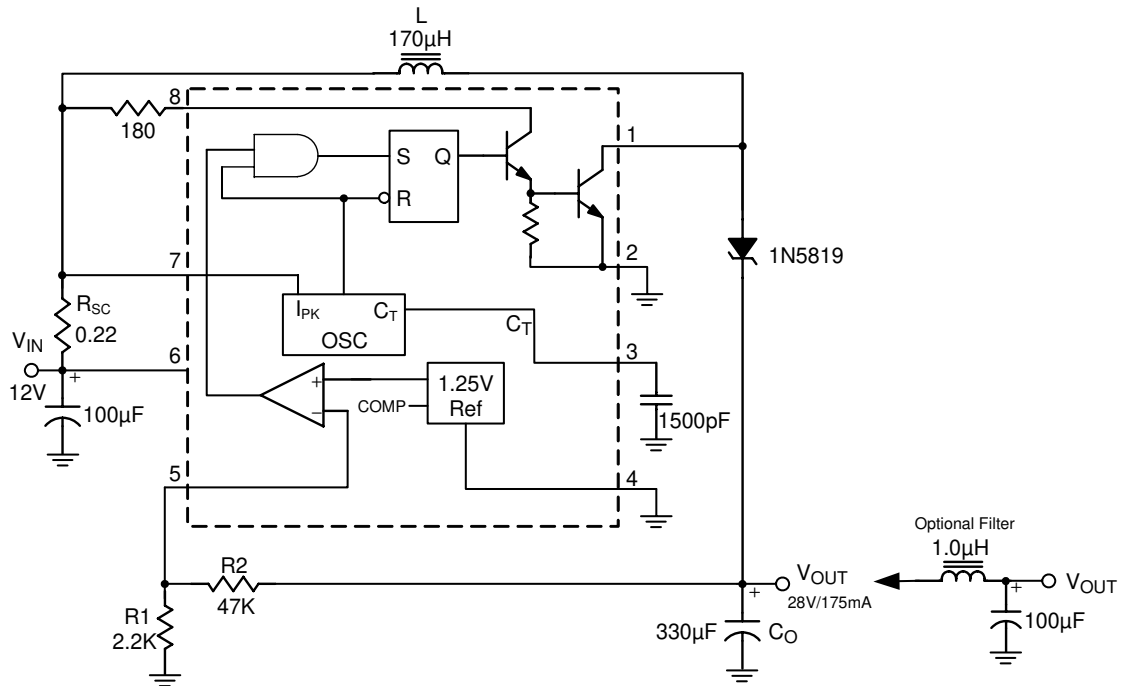
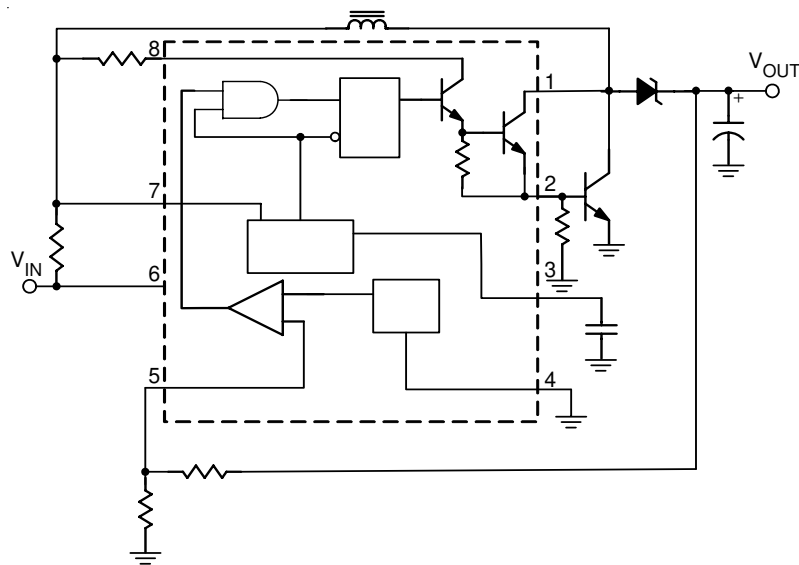
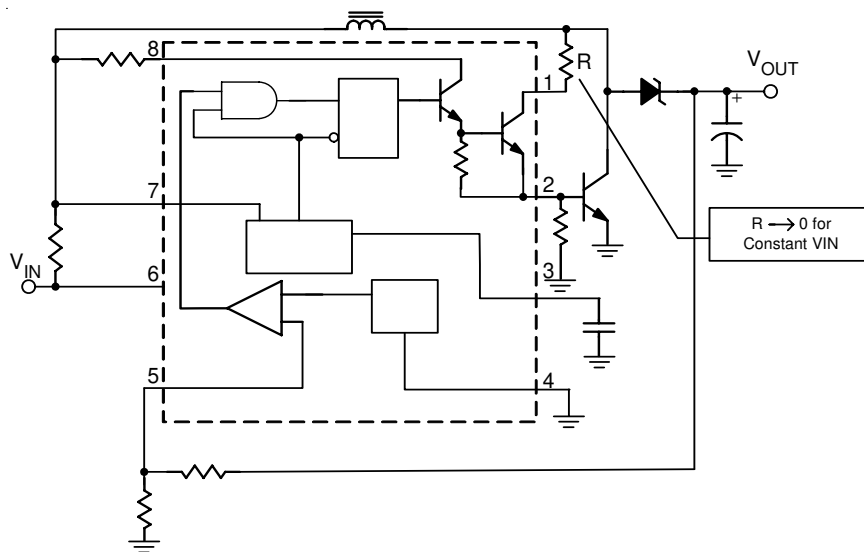

Figure 1. Step-up Converter



(a) External NPN Switch



(b) External NPN Saturated Switch (See Note)

Figure 2. External Current Boost Connections for I_C Peak Greater than 1.5A

Note: If the output switch is driven into hard saturation (non-Darlington configuration) at low switch currents ($\leq 300\text{mA}$) and high driver currents ($\geq 30\text{mA}$), it may take up to $2.0\mu\text{s}$ to come out of saturation. This condition will shorten the off time at frequencies $\geq 30\text{kHz}$, and is magnified at high temperature. This condition does not occur with a Darlington configuration, since the output switch cannot saturate. If a non-Darlington configuration is used, the following output drive condition is recommended.

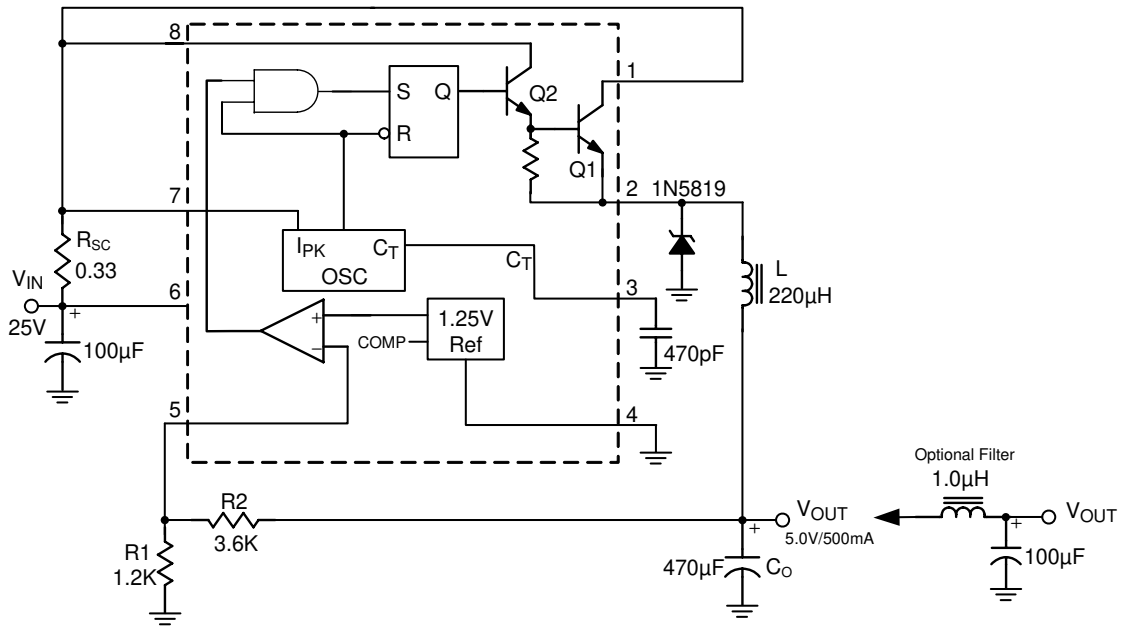
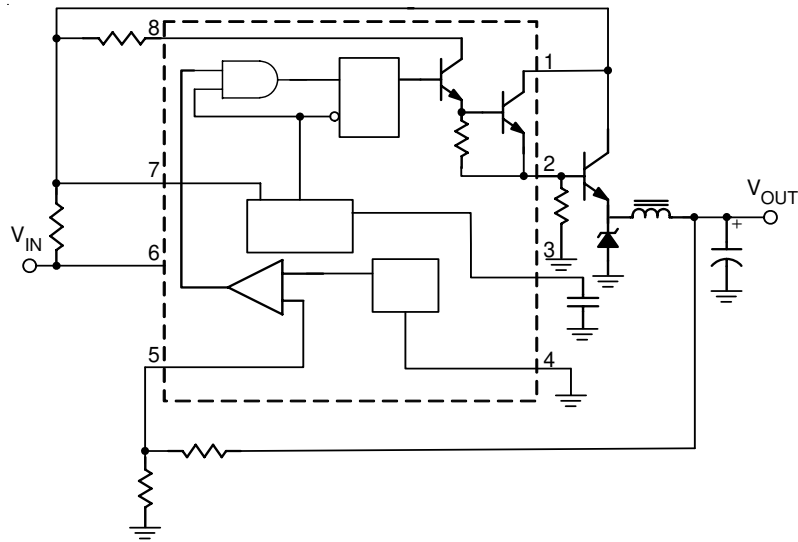
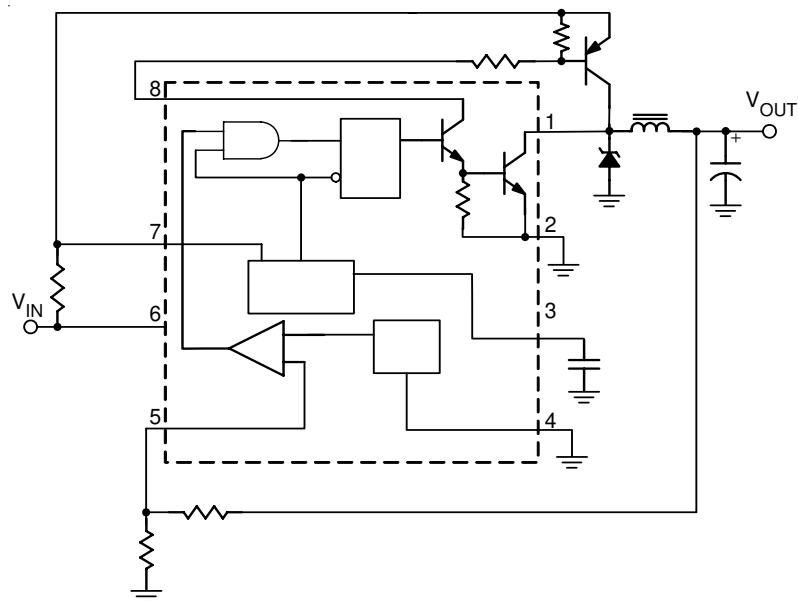

Figure 3. Step-down Converter



(a) External NPN Switch



(b) External PNP Saturated Switch

Figure 4. External Current Boost Connections for I_C Peak Greater than 1.5A

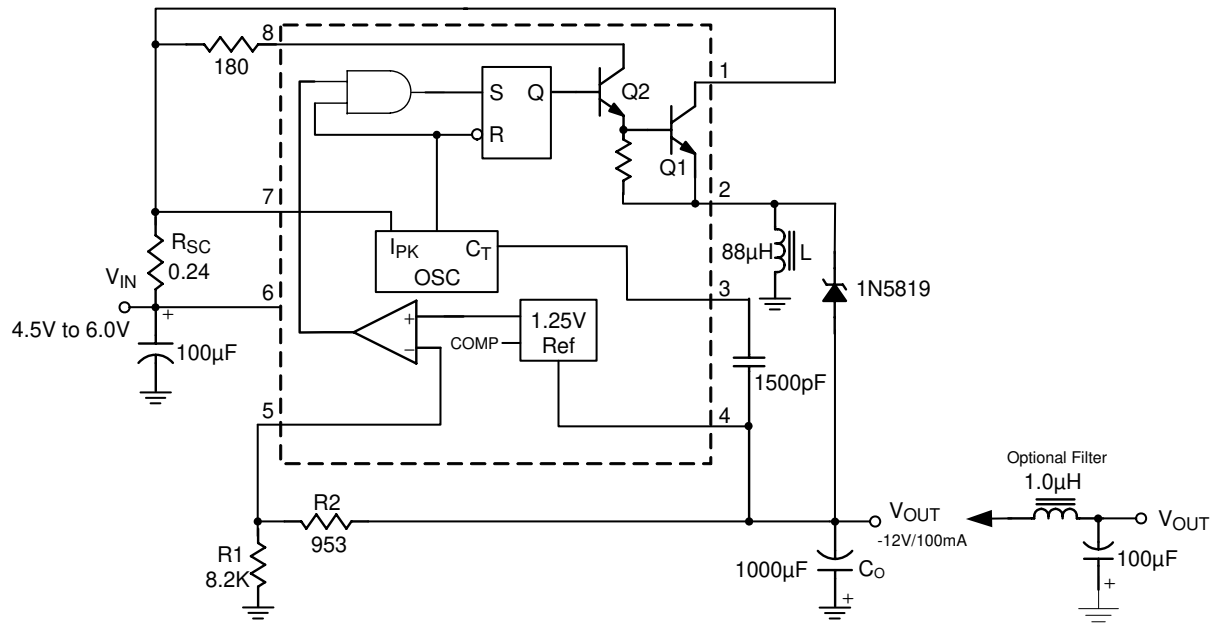
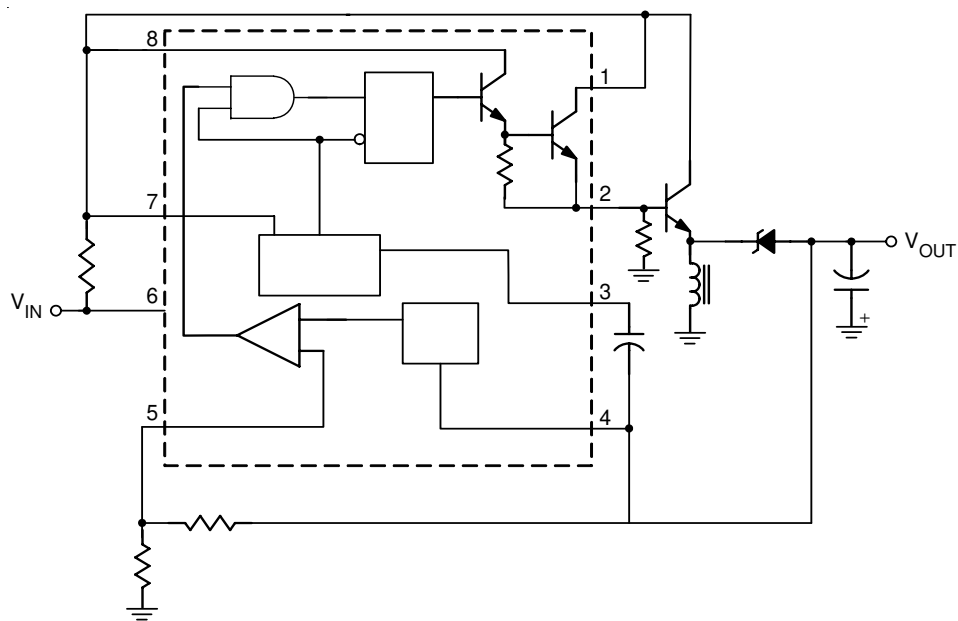
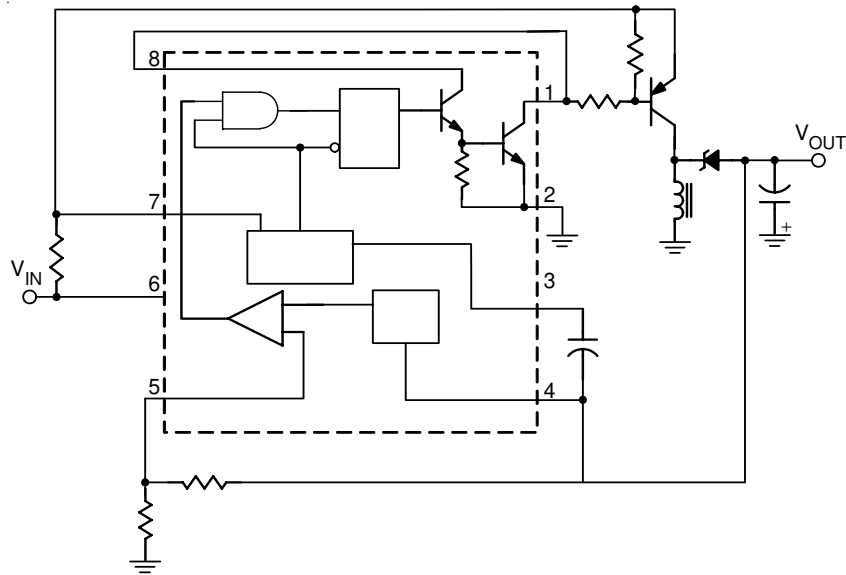

Figure 5. Voltage Inverting Converter



(a) External NPN Switch



(b) External PNP Saturated Switch

Figure 6. External Current Boost Connections for Peak Greater than 1.5A

Design Formula Table

Calculation	Step-up	Step-down	Voltage-Inverting
t_{on}/t_{off}	$\frac{V_{OUT} + V_F - V_{IN(MIN)}}{V_{IN(MIN)} - V_{SAT}}$	$\frac{V_{OUT} + V_F}{V_{IN(MIN)} - V_{SAT} - V_{OUT}}$	$\frac{ V_{OUT} + V_F}{V_{IN} - V_{SAT}}$
$(t_{on} + t_{off})$	$\frac{1}{f}$	$\frac{1}{f}$	$\frac{1}{f}$
t_{off}	$\frac{t_{on} + t_{off}}{\frac{t_{on}}{t_{off}} + 1}$	$\frac{t_{on} + t_{off}}{\frac{t_{on}}{t_{off}} + 1}$	$\frac{t_{on} + t_{off}}{\frac{t_{on}}{t_{off}} + 1}$
t_{on}	$(t_{on} + t_{off}) - t_{off}$	$(t_{on} + t_{off}) - t_{off}$	$(t_{on} + t_{off}) - t_{off}$
C_T	$4.0 \times 10^{-5} t_{on}$	$4.0 \times 10^{-5} t_{on}$	$4.0 \times 10^{-5} t_{on}$
$I_{pk(SWITCH)}$	$2 I_{OUT(MAX)} \left(\frac{t_{on}}{t_{off}} + 1 \right)$	$2 I_{OUT(MAX)}$	$2 I_{OUT(MAX)} \left(\frac{t_{on}}{t_{off}} + 1 \right)$
R_{SC}	$0.3/I_{pk(SWITCH)}$	$0.3/I_{pk(SWITCH)}$	$0.3/I_{pk(SWITCH)}$
$L(\text{min})$	$\left(\frac{(V_{IN(MIN)} - V_{SAT})}{I_{pk(SWITCH)}} \right) t_{on(MAX)}$	$\left(\frac{(V_{IN(MIN)} - V_{SAT})}{I_{pk(SWITCH)}} \right) t_{on(MAX)}$	$\left(\frac{(V_{IN(MIN)} - V_{SAT})}{I_{pk(SWITCH)}} \right) t_{on(MAX)}$
C_O	$9 \frac{I_{OUT} t_{on}}{V_{ripple(pp)}}$	$\frac{I_{pk(SWITCH)}(t_{on} + t_{off})}{8V_{ripple(pp)}}$	$9 \frac{I_{OUT} t_{on}}{V_{ripple(pp)}}$

V_{SAT} : Saturation voltage of the output switch.

V_F : Forward voltage drop of the output rectifier.

The following power supply characteristics must be chosen:

V_{IN} : Nominal input voltage.

V_{OUT} : Desired output voltage $|V_{OUT}| = 1.25 \left(1 + \frac{R_2}{R_1} \right)$

I_{OUT} : Desired output current.

f : Minimum desired output switching frequency at the selected values of V_{in} and I_o .

$V_{ripple(pp)}$: Desired peak-to-peak output ripple voltage. In practice, the calculated capacitor value needs to be increased due to its equivalent series resistance and board layout. The ripple voltage should be kept to a low value since it directly affects the line and load regulation.

Absolute Maximum Ratings (Note 1)

- Power Supply Voltage ----- 30V
- Feedback Input Voltage Range ----- -0.3 to +30V
- Switch Collector Voltage ----- 30V
- Switch Emitter Voltage ----- 30V
- Switch Collector to Emitter Voltage ----- 30V
- Driver Collector Voltage ----- 30V
- Driver Collector Current (see Note) ----- 100mA
- Switch Current ----- 1.5A
- Power Dissipation, P_D @ $T_A = 25^\circ\text{C}$
 - DIP-8 ----- 1.25W
 - SOP-8 ----- 0.625W
- Package Thermal Resistance (Note 2)
 - DIP-8, θ_{JA} ----- 100°C/W
 - SOP-8, θ_{JA} ----- 160°C/W
- Junction Temperature ----- 150°C
- Storage Temperature Range ----- -65 to 150°C

Recommended Operating Conditions (Note 3)

- Power Supply Input Voltage Range ----- 3V to 30V
- Junction Temperature Range ----- -40°C to 125°C
- Ambient Temperature Range ----- -40°C to 85°C

Electrical Characteristics

($V_{CC} = 5\text{V}$, $T_A = 25^\circ\text{C}$, unless otherwise specified)

Parameter	Symbol	Test Conditions	Min	Typ	Max	Unit
Oscillator						
Frequency		$V_{PIN5} = 0\text{V}$, $C_T = 1.0\text{nF}$	26	38	48	kHz
Charge Current	I_{CHG}	$5.0\text{V} \leq V_{CC} \leq 30\text{V}$	25	36	43	μA
Discharge Current	I_{DISCHG}	$5.0\text{V} \leq V_{CC} \leq 30\text{V}$	160	250	290	μA
Discharge to Charge Current Ratio		Pin 7 to VCC	5.5	6.9	7.9	--
Current Limit Sense Voltage	V_{LIM}	$I_{CHG} = I_{DISCHG}$	280	330	380	mV
Output Switch						
Saturation Voltage, Darlington Connection		$I_{SW} = 1.0\text{A}$, Pins1, 8 connected	--	1.0	1.3	V
Saturation Voltage, Darlington Connection		$I_{SW} = 1.0\text{A}$, $R_{PIN8} = 82\Omega$ to VCC, Forced $\beta \cong 20$	--	0.45	0.7	V
DC Current Gain		$I_{SW} = 1.0\text{A}$, $V_{CE} = 5.0\text{V}$	50	75	--	--
Collector Off-state Current		$V_{CE} = 30\text{V}$	--	0.01	100	μA

To be continued

Parameter	Symbol	Test Conditions	Min	Typ	Max	Unit
Comparator						
Threshold Voltage			1.225	1.25	1.275	V
Threshold Voltage Line Regulation		$3.0V \leq VCC \leq 30V$	--	1.4	5.0	mV
Input Bias Current	I _{BIAS}	V _{IN} = 0V	--	-20	-400	nA
Total Device						
Supply Current	I _{CC}	VCC = 5.0V to 30V, C _T = 1.0nF, Pin7 = VCC, V _{PIN5} > V _{TH} , Pin2 = GND, Remaining pins open	--	3.0	4.5	mA

Note 1. Stresses listed as the above “Absolute Maximum Ratings” may cause permanent damage to the device. These are for stress ratings. Functional operation of the device at these or any other conditions beyond those indicated in the operational sections of the specifications is not implied. Exposure to absolute maximum rating conditions for extended periods may remain possibility to affect device reliability.

Note 2. θ_{JA} is measured in the natural convection at $T_A = 25^\circ\text{C}$ on a low effective thermal conductivity test board of JEDEC 51-3 thermal measurement standard.

Note 3. The device is not guaranteed to function outside its operating conditions.

Typical Operating Characteristics

Output Switch On-Off Time vs. Oscillator Timing Capacitor

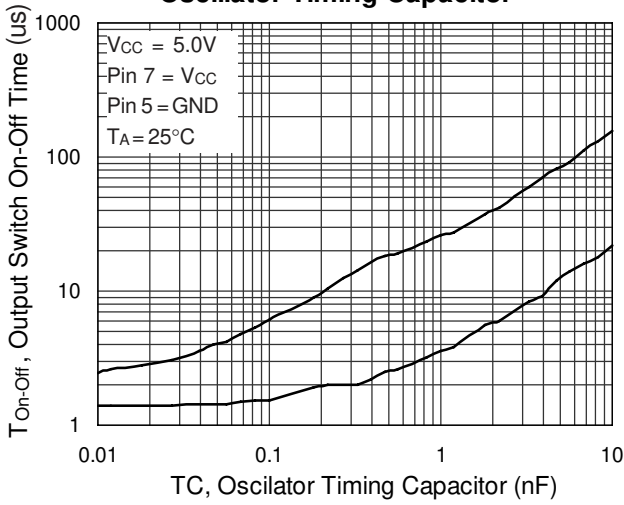

Timing Capacitor Waveform

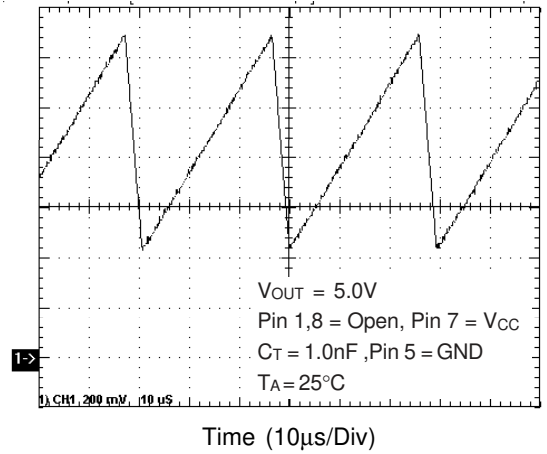

Emitter Follower Configuration Output Saturation Voltage vs. Emitter Current

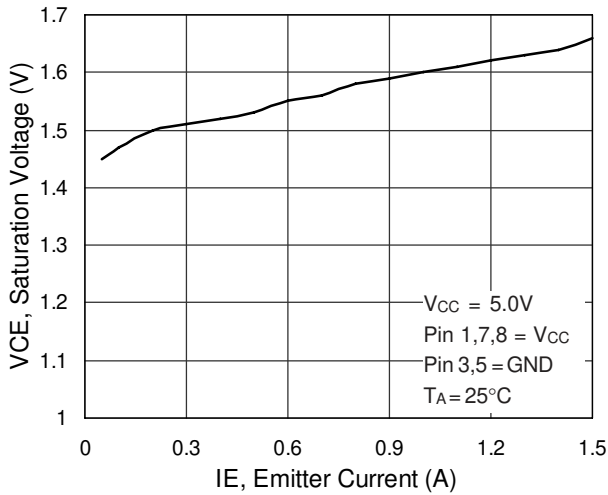

Common Emitter Configuration Output Switch Saturation Voltage vs. Collector Current

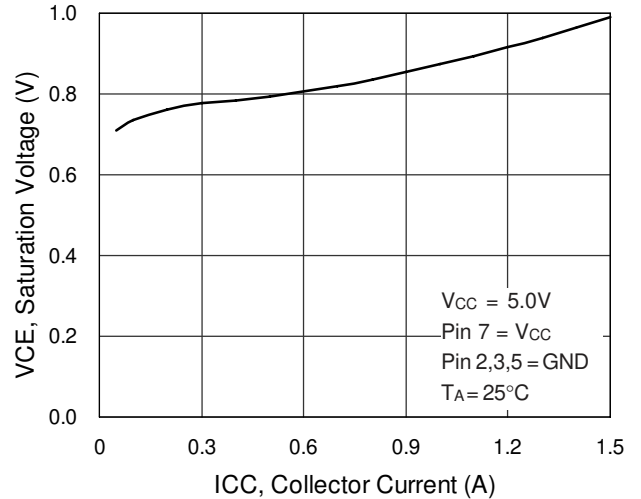

Standby Supply Current vs. Supply Voltage

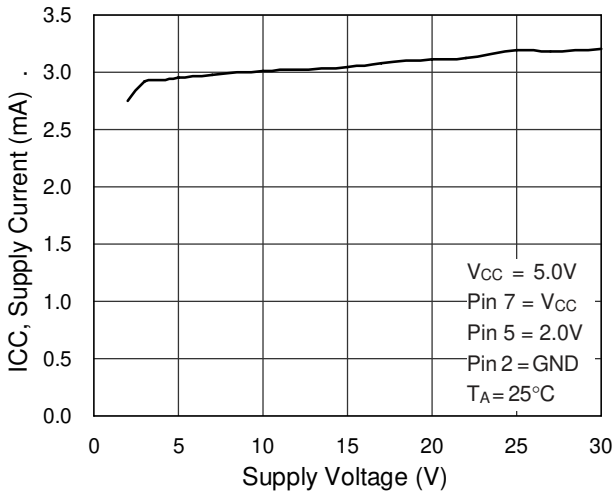

Current Limit Sense Voltage vs. Temperature

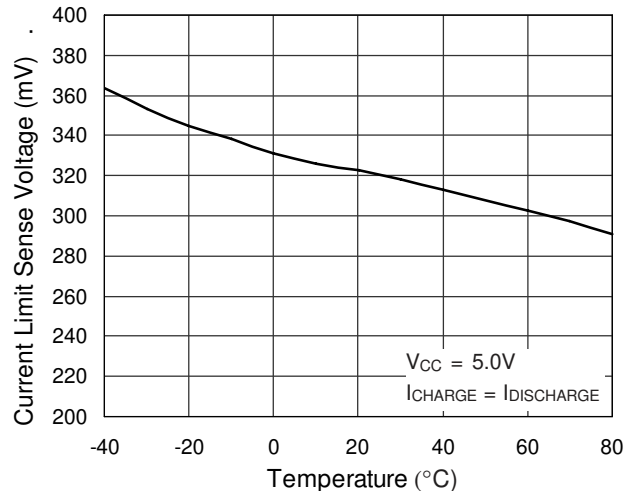

I_C vs. V_{CE(Q1)} Curve

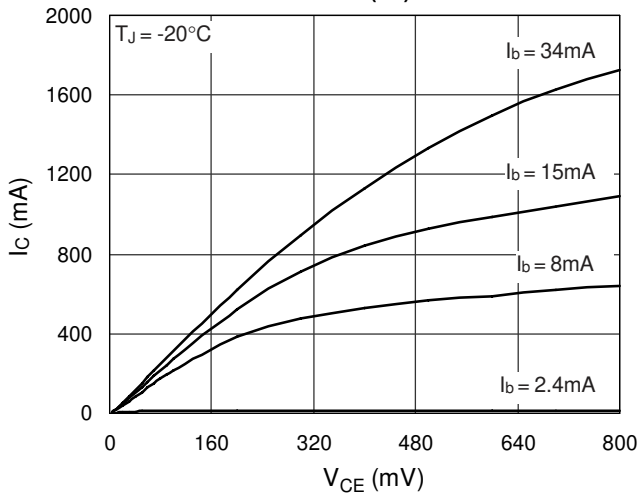

I_C vs. V_{CE(Q1)} Curve

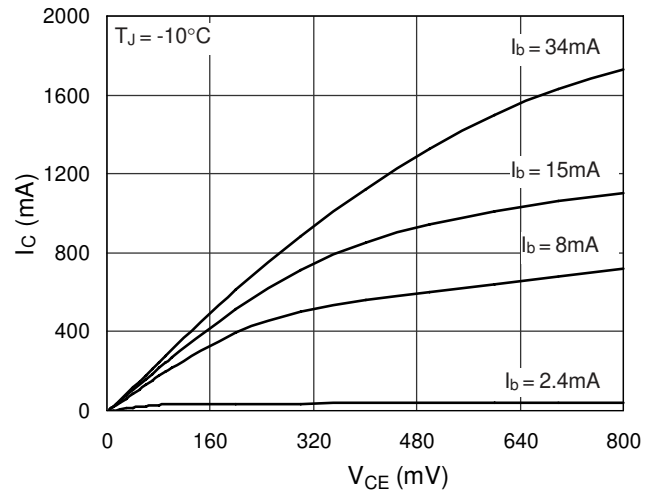

I_C vs. V_{CE(Q1)} Curve

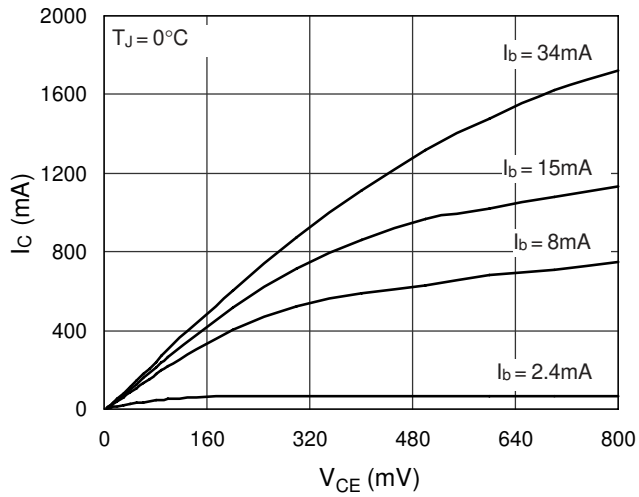

I_C vs. V_{CE(Q1)} Curve

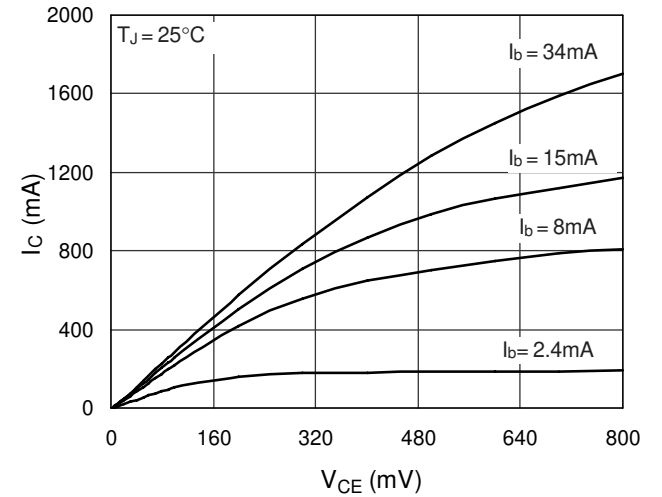

I_C vs. V_{CE(Q1)} Curve

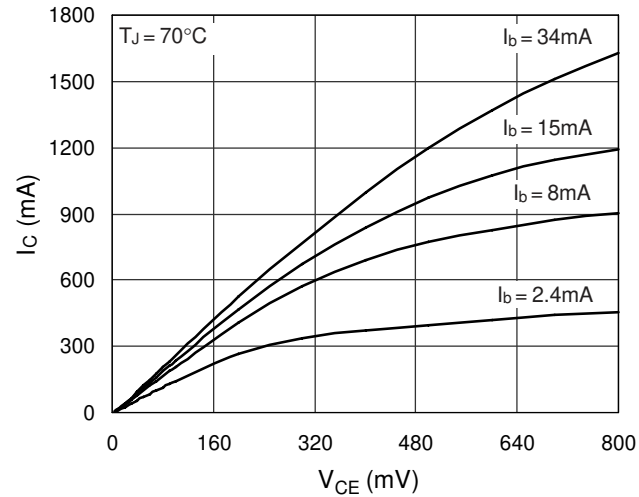

Outline Dimension

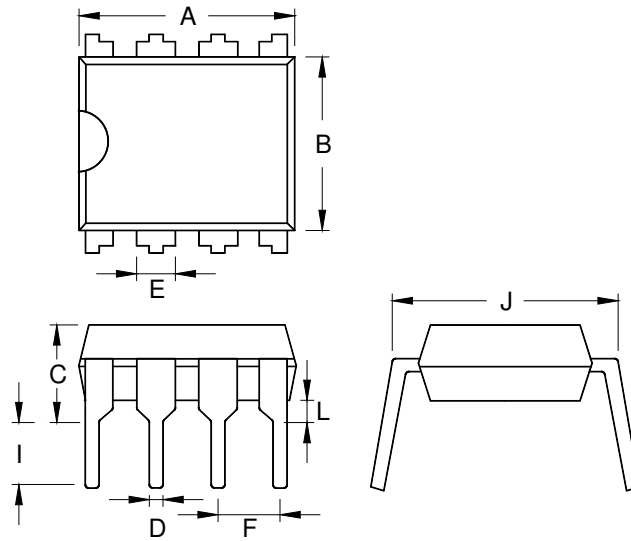

Symbol	Dimensions In Millimeters		Dimensions In Inches	
	Min	Max	Min	Max
A	9.068	9.627	0.357	0.379
B	6.198	6.604	0.244	0.260
C	3.556	4.318	0.140	0.170
D	0.356	0.559	0.014	0.022
E	1.397	1.651	0.055	0.065
F	2.337	2.743	0.092	0.108
I	3.048	3.556	0.120	0.140
J	7.366	8.255	0.290	0.325
L	0.381		0.015	

8-Lead DIP Plastic Package

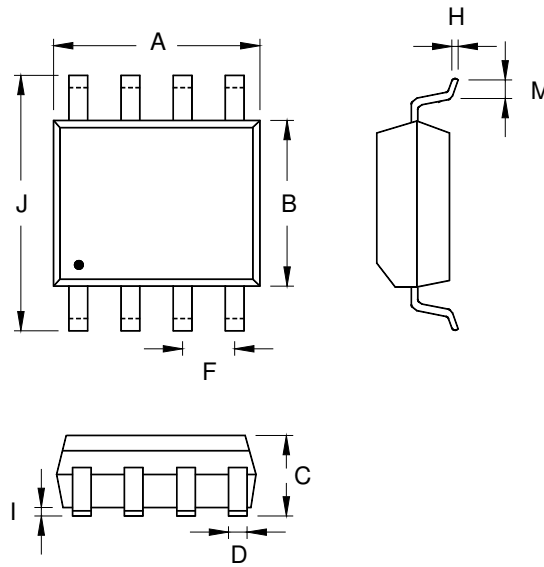

Symbol	Dimensions In Millimeters		Dimensions In Inches	
	Min	Max	Min	Max
A	4.801	5.004	0.189	0.197
B	3.810	3.988	0.150	0.157
C	1.346	1.753	0.053	0.069
D	0.330	0.508	0.013	0.020
F	1.194	1.346	0.047	0.053
H	0.170	0.254	0.007	0.010
I	0.050	0.254	0.002	0.010
J	5.791	6.200	0.228	0.244
M	0.400	1.270	0.016	0.050

8-Lead SOP Plastic Package

Richtek Technology Corporation

Headquarter
 5F, No. 20, Taiyuen Street, Chupei City
 Hsinchu, Taiwan, R.O.C.
 Tel: (8863)5526789 Fax: (8863)5526611

Richtek Technology Corporation

Taipei Office (Marketing)
 5F, No. 95, Minchiuan Road, Hsintien City
 Taipei County, Taiwan, R.O.C.
 Tel: (8862)86672399 Fax: (8862)86672377
 Email: marketing@richtek.com

Information that is provided by Richtek Technology Corporation is believed to be accurate and reliable. Richtek reserves the right to make any change in circuit design, specification or other related things if necessary without notice at any time. No third party intellectual property infringement of the applications should be guaranteed by users when integrating Richtek products into any application. No legal responsibility for any said applications is assumed by Richtek.