

THIS DRAWING IS UNPUBLISHED. RELEASED FOR PUBLICATION 20
 © COPYRIGHT 20 BY - ALL RIGHTS RESERVED.

REVISIONS					
P	LTR	DESCRIPTION	DATE	DWN	APVD
A1	ECR-17-008664		17JUN2017	CH	CW
A2	ECR-18-011767		01AUG2018	JZ	CW
B	ECR-20-008190		10AUG2020	WQR	CW
B1	ECR-21-105138		29JUN2021	WQR	CW

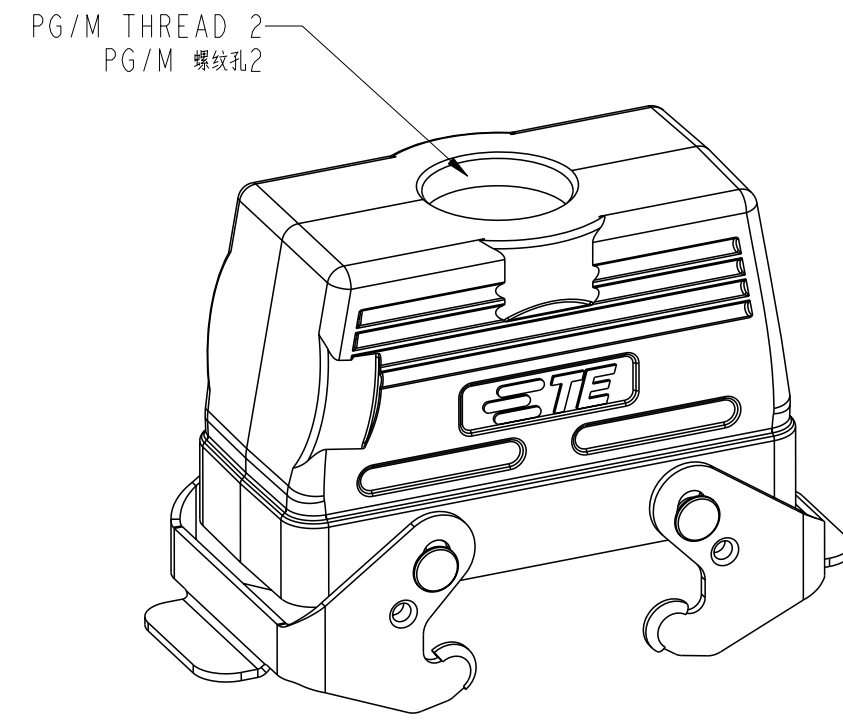
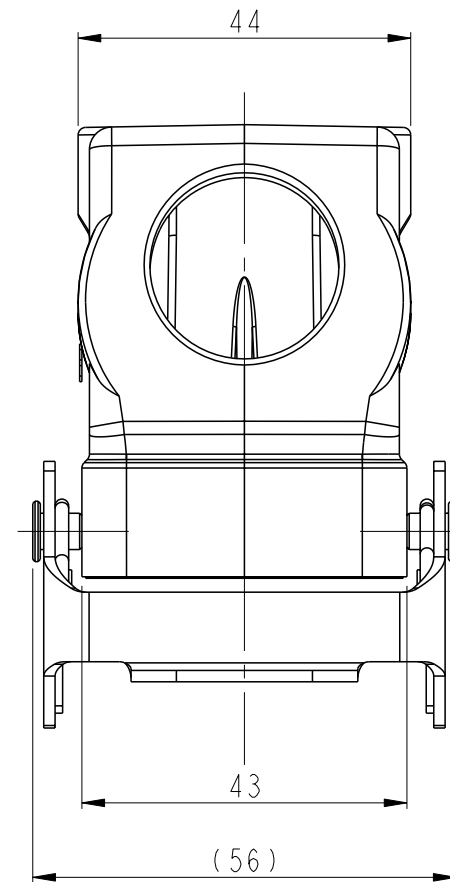
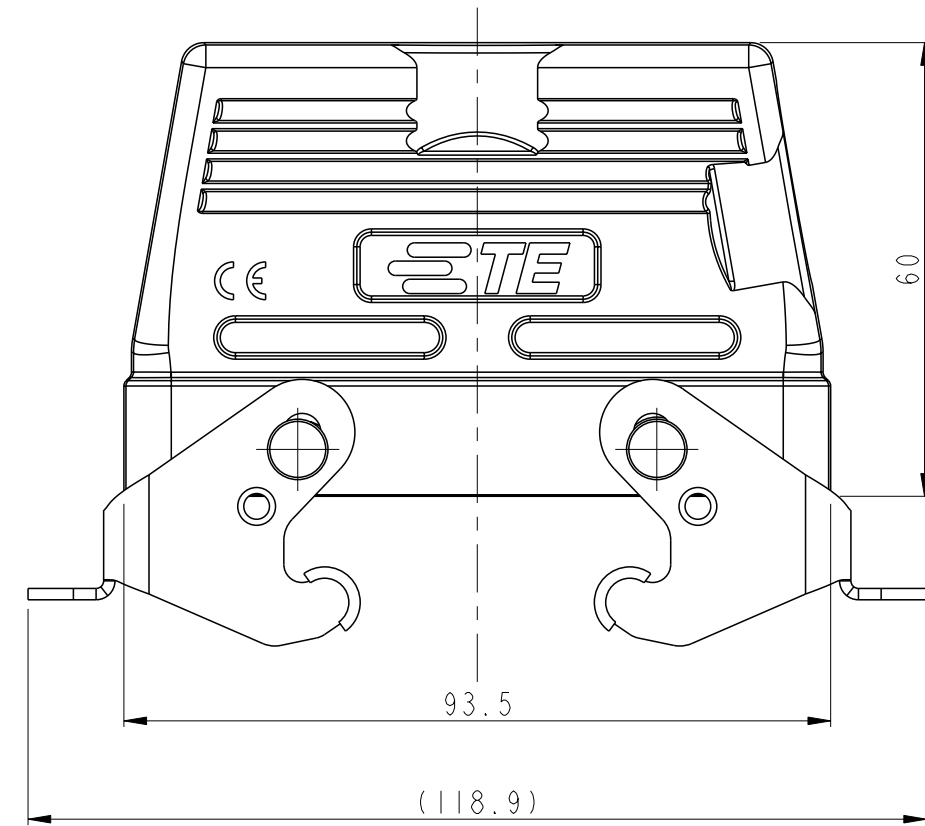

SCALE 4:5

TYPE 2: LOW CONSTRUCTION, TOP ENTRY WITH STEEL DOUBLE LOCKING
 OTHER SPEC REFER TO TYPE 1
 类型2: 低结构, 顶出, 带彩锌双扣, 其它规格参照类型1

NOTES:

- 1. TECHNICAL CHARACTERISTICS:
 HOOD MATERIAL: DIE CAST ALUMINIUM ALLOY
 SURFACE: POWDER COATED, GREY
 DEGREE OF PROTECTION: IP65 (MATED)

注释:

- 1. 技术参数:
 上壳材料: 铝合金
 表面处理: 灰色粉末喷涂
 防护等级: IP65(配合)

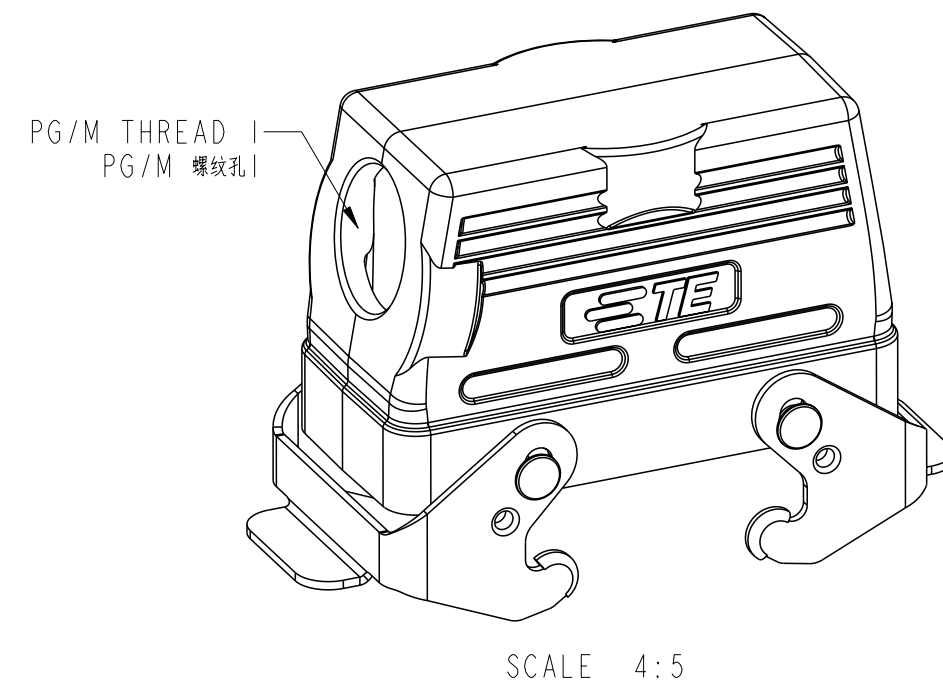
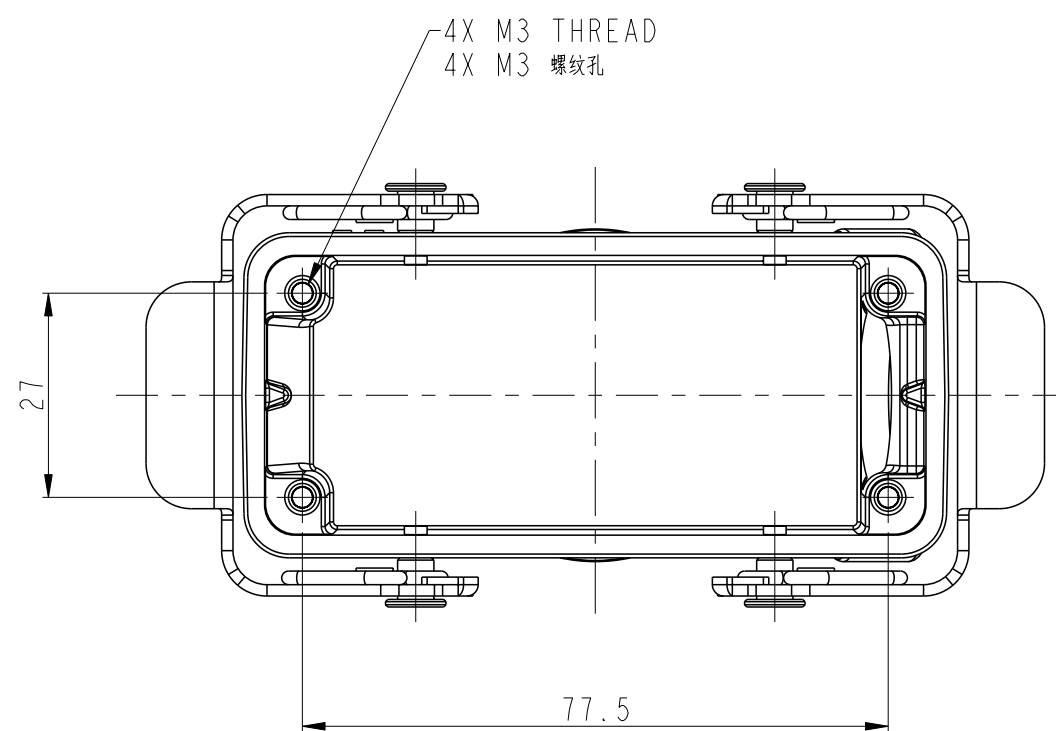

SCALE 4:5

TYPE 1: LOW CONSTRUCTION, SIDE ENTRY WITH STEEL DOUBLE LOCKING
 类型1: 低结构, 侧出, 带彩锌双扣

PART NUMBER 料号	PART DESCRIPTION 描述	PG/M THREAD 1 PG/M 螺纹孔1	PG/M THREAD 2 PG/M 螺纹孔2	TYPE 类型
T1260162132-000	H16B-TGB-M32 H16B HOOD, TOP ENTRY M32, METAL DOUBLE LOCKING, POWDER COATED, GREY H16B上壳, 顶出M32, 彩锌双扣, 灰色粉末喷涂	-	M32	TYPE 2 类型2
T1260162125-000	H16B-TGB-M25 H16B HOOD, TOP ENTRY M25, METAL DOUBLE LOCKING, POWDER COATED, GREY H16B上壳, 顶出M25, 彩锌双扣, 灰色粉末喷涂	-	M25	
T1260162121-000	H16B-TGB-PG21 H16B HOOD, TOP ENTRY PG21, METAL DOUBLE LOCKING, POWDER COATED, GREY H16B上壳, 顶出PG21, 彩锌双扣, 灰色粉末喷涂	-	PG21	
T1250162132-000	H16B-TSB-M32 H16B HOOD, SIDE ENTRY M32, METAL DOUBLE LOCKING, POWDER COATED, GREY H16B上壳, 侧出M32, 彩锌双扣, 灰色粉末喷涂	M32	-	TYPE 1 类型1
T1250162125-000	H16B-TSB-M25 H16B HOOD, SIDE ENTRY M25, METAL DOUBLE LOCKING, POWDER COATED, GREY H16B上壳, 侧出M25, 彩锌双扣, 灰色粉末喷涂	M25	-	
T1250162121-000	H16B-TSB-PG21 H16B HOOD, SIDE ENTRY PG21, METAL DOUBLE LOCKING, POWDER COATED, GREY H16B上壳, 侧出PG21, 彩锌双扣, 灰色粉末喷涂	PG21	-	
T1250162120-000	H16B-TSB-M20 H16B HOOD, SIDE ENTRY M20, METAL DOUBLE LOCKING, POWDER COATED, GREY H16B上壳, 侧出M20, 彩锌双扣, 灰色粉末喷涂	M20	-	

THIS DRAWING IS A CONTROLLED DOCUMENT.

DWN JEREMY.ZHANG 01AUG2018	
CHK GINO.YAO 01AUG2018	
APVD CHRIS.WANG 01AUG2018	
PRODUCT SPEC 108-137013	
MATERIAL -	TOLERANCES UNLESS OTHERWISE SPECIFIED: 0 PLC ± 1 PLC ± 2 PLC ± 3 PLC ± 4 PLC ± ANGLES ± FINISH -
Customer Drawing	

TE Connectivity	
NAME H16B-TSB/TGB/TGBH/TSBH/TFBH-M/PG	
SIZE A2	CAGE CODE 00779
DRAWING NO G-T12X01621XX000	RESTRICTED TO -
SCALE 1:1	SHEET 1 OF 3
REV B1	

Printed on 2 Jul 2021 11:06 (China Standard Time) from TE343646

THIS DRAWING IS UNPUBLISHED. RELEASED FOR PUBLICATION 20
 © COPYRIGHT 20 BY - ALL RIGHTS RESERVED.

REVISIONS				
P	LTR	DESCRIPTION	DATE	APVD
-	-	SEE SHEET 1	-	-

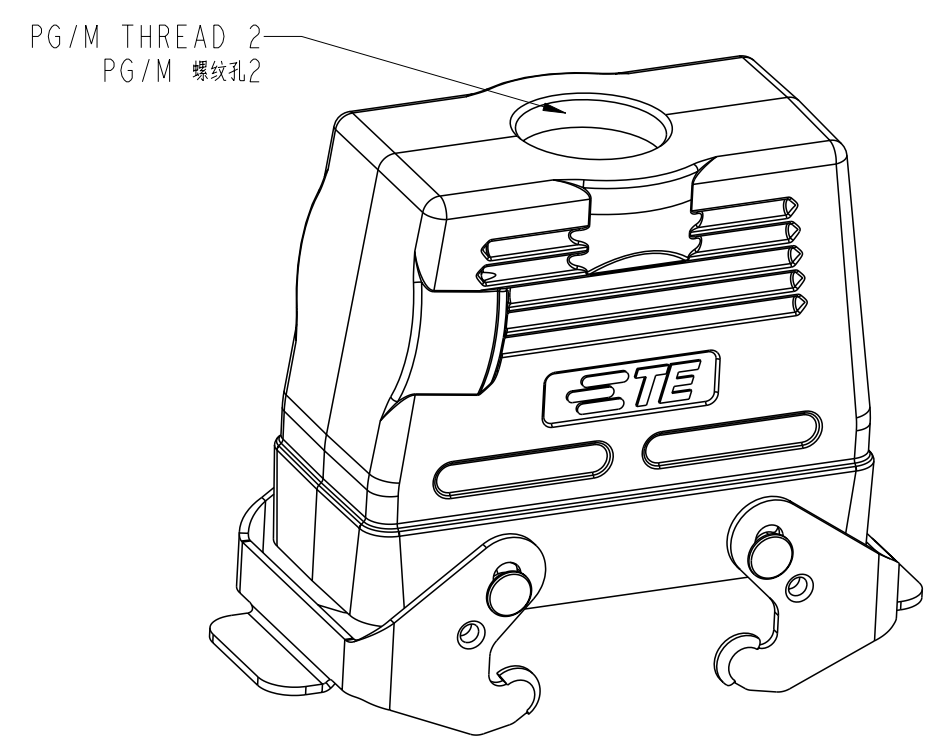
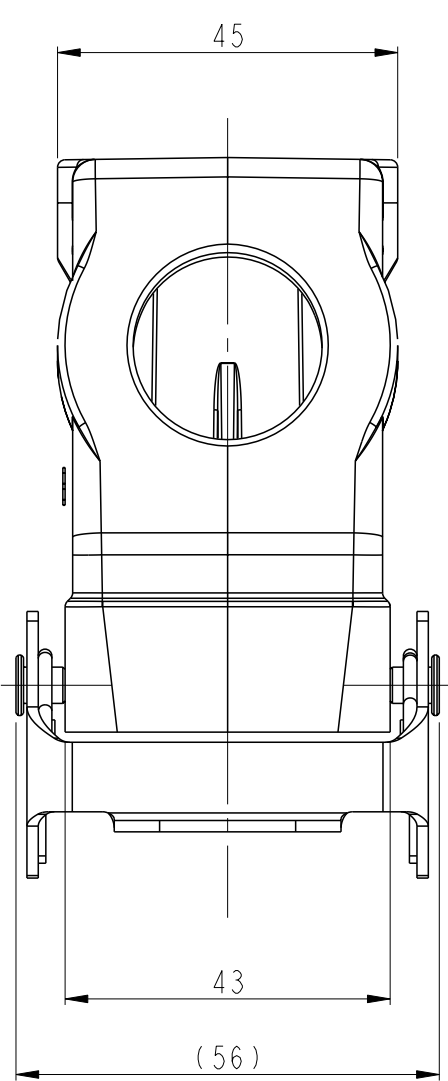
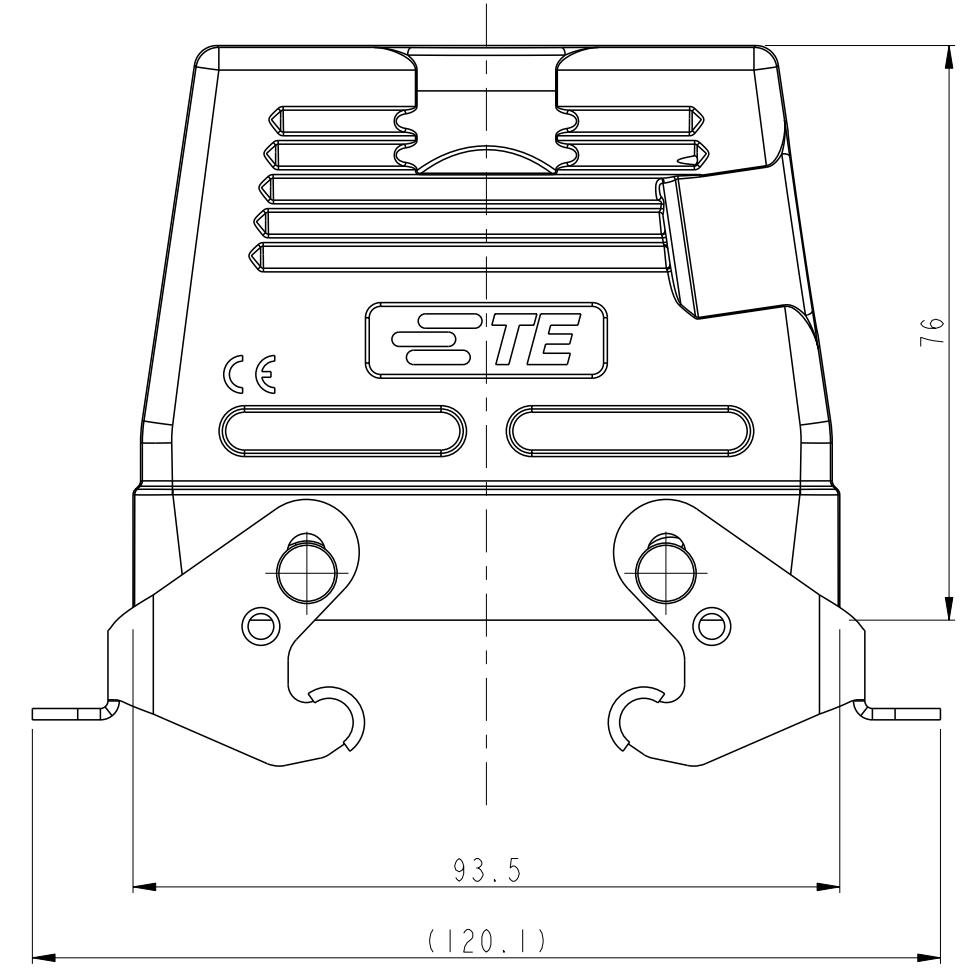

SCALE 4:5

TYPE 4: HIGH CONSTRUCTION, TOP ENTRY WITH STEEL DOUBLE LOCKING OTHER SPEC REFER TO TYPE 3
 类型4: 高结构, 顶出, 带彩锌双扣, 其它规格参照类型3

NOTES:
SEE SHEET 1

PART NUMBER	PART DESCRIPTION	PG/M THREAD 1	PG/M THREAD 2	TYPE
料号	描述	PG/M 螺纹孔1	PG/M 螺纹孔2	类型
T1280162140-000	H16B-TGBH-M40 H16B HOOD, TOP ENTRY M40, METAL DOUBLE LOCKING, HIGH CONSTRUCTION, POWDER COATED, GREY H16B上壳, 顶出M40, 彩锌双扣, 高结构, 灰色粉末喷涂	-	M40	TYPE 4 类型4
T1280162132-000	H16B-TGBH-M32 H16B HOOD, TOP ENTRY M32, METAL DOUBLE LOCKING, HIGH CONSTRUCTION, POWDER COATED, GREY H16B上壳, 顶出M32, 彩锌双扣, 高结构, 灰色粉末喷涂	-	M32	
T1280162129-000	H16B-TGBH-PG29 H16B HOOD, TOP ENTRY PG29, METAL DOUBLE LOCKING, HIGH CONSTRUCTION, POWDER COATED, GREY H16B上壳, 顶出PG29, 彩锌双扣, 高结构, 灰色粉末喷涂	-	PG29	
T1280162125-000	H16B-TGBH-M25 H16B HOOD, TOP ENTRY M25, METAL DOUBLE LOCKING, HIGH CONSTRUCTION, POWDER COATED, GREY H16B上壳, 顶出M25, 彩锌双扣, 高结构, 灰色粉末喷涂	-	M25	
T1280162121-000	H16B-TGBH-PG21 H16B HOOD, TOP ENTRY PG21, METAL DOUBLE LOCKING, HIGH CONSTRUCTION, POWDER COATED, GREY H16B上壳, 顶出PG21, 彩锌双扣, 高结构, 灰色粉末喷涂	-	PG21	
T1270162140-000	H16B-TSBH-M40 H16B HOOD, SIDE ENTRY M40, METAL DOUBLE LOCKING, HIGH CONSTRUCTION, POWDER COATED, GREY H16B上壳, 侧出M40, 彩锌双扣, 高结构, 灰色粉末喷涂	M40	-	TYPE 3 类型3
T1270162132-000	H16B-TSBH-M32 H16B HOOD, SIDE ENTRY M32, METAL DOUBLE LOCKING, HIGH CONSTRUCTION, POWDER COATED, GREY H16B上壳, 侧出M32, 彩锌双扣, 高结构, 灰色粉末喷涂	M32	-	
T1270162129-000	H16B-TSBH-PG29 H16B HOOD, SIDE ENTRY PG29, METAL DOUBLE LOCKING, HIGH CONSTRUCTION, POWDER COATED, GREY H16B上壳, 侧出PG29, 彩锌双扣, 高结构, 灰色粉末喷涂	PG29	-	
T1270162125-000	H16B-TSBH-M25 H16B HOOD, SIDE ENTRY M25, METAL DOUBLE LOCKING, HIGH CONSTRUCTION, POWDER COATED, GREY H16B上壳, 侧出M25, 彩锌双扣, 高结构, 灰色粉末喷涂	M25	-	
T1270162121-000	H16B-TSBH-PG21 H16B HOOD, SIDE ENTRY PG21, METAL DOUBLE LOCKING, HIGH CONSTRUCTION, POWDER COATED, GREY H16B上壳, 侧出PG21, 彩锌双扣, 高结构, 灰色粉末喷涂	PG21	-	

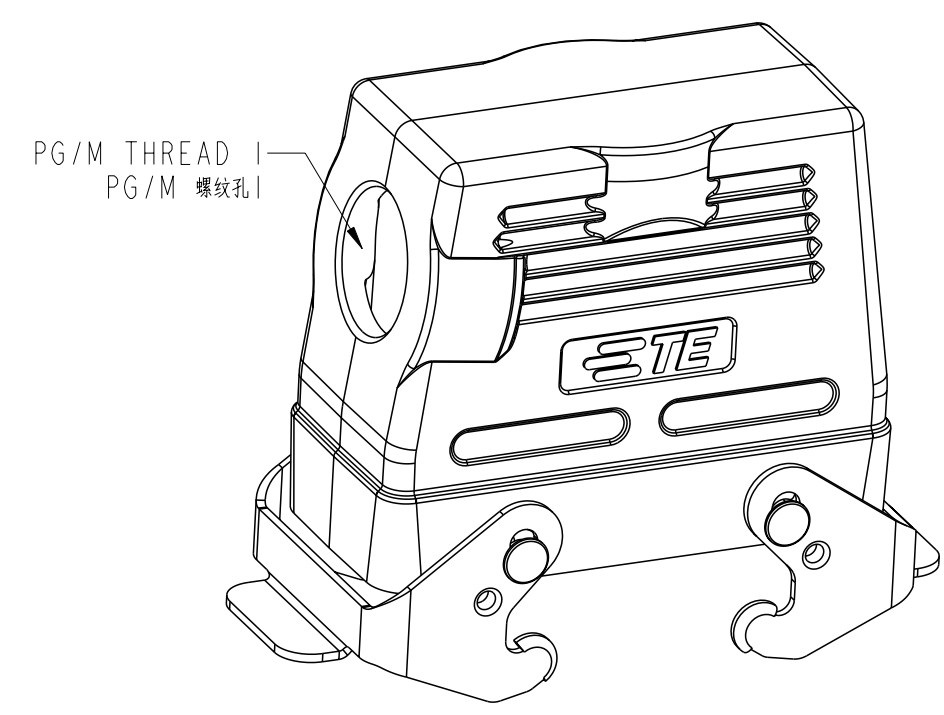
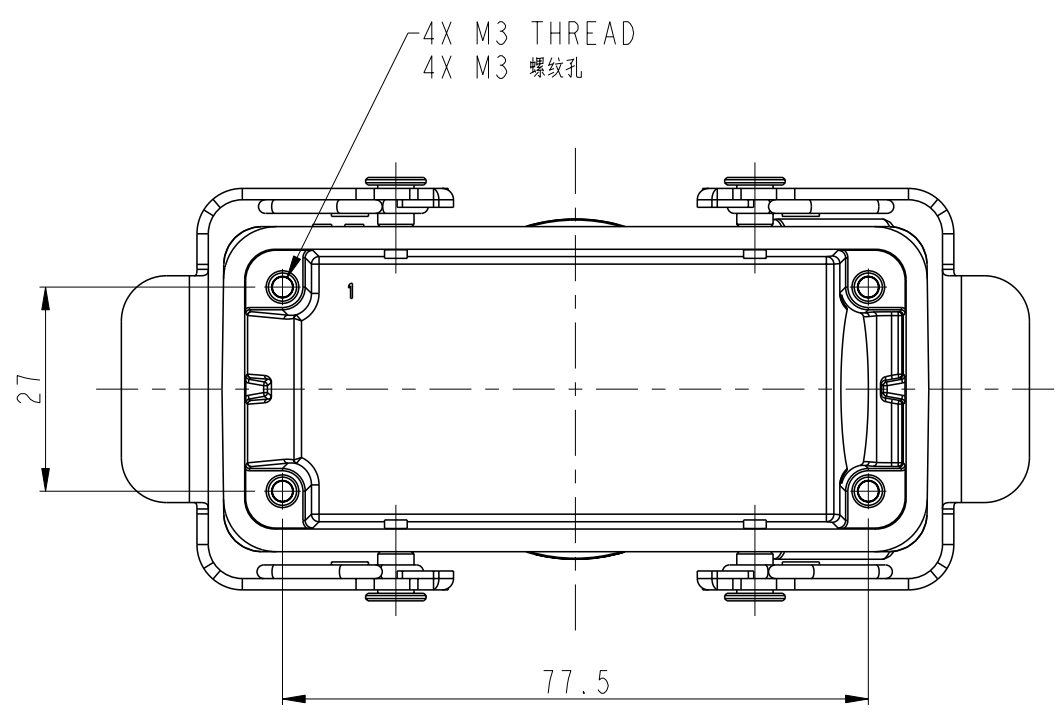

SCALE 4:5

TYPE 3: HIGH CONSTRUCTION, SIDE ENTRY WITH STEEL DOUBLE LOCKING
 类型3: 高结构, 侧出, 带彩锌双扣

THIS DRAWING IS A CONTROLLED DOCUMENT.

DWN: 01AUG2018 JEREMY.ZHANG
 CHK: 01AUG2018 GINO.YAO
 APVD: 01AUG2018 CHRIS.WANG

TE Connectivity

NAME: H16B-TSB/TGB/TGBH/TSBH/TFBH-M/PG

PRODUCT SPEC: 108-137013
 APPLICATION SPEC: 114-137013

SIZE: A2 CAGE CODE: 00779 DRAWING NO: C-T12X01621XX000 RESTRICTED TO: -

Customer Drawing SCALE: 1:1 SHEET: 2 OF 3 REV: B1

Printed on: 2 Jul 2021 11:06 (China Standard Time) from: TE343666

THIS DRAWING IS UNPUBLISHED. RELEASED FOR PUBLICATION 20
 © COPYRIGHT 20 BY - ALL RIGHTS RESERVED.

REVISIONS				
P	LTR	DESCRIPTION	DATE	APVD
-		SEE SHEET 1	-	-

NOTES:
SEE SHEET 1

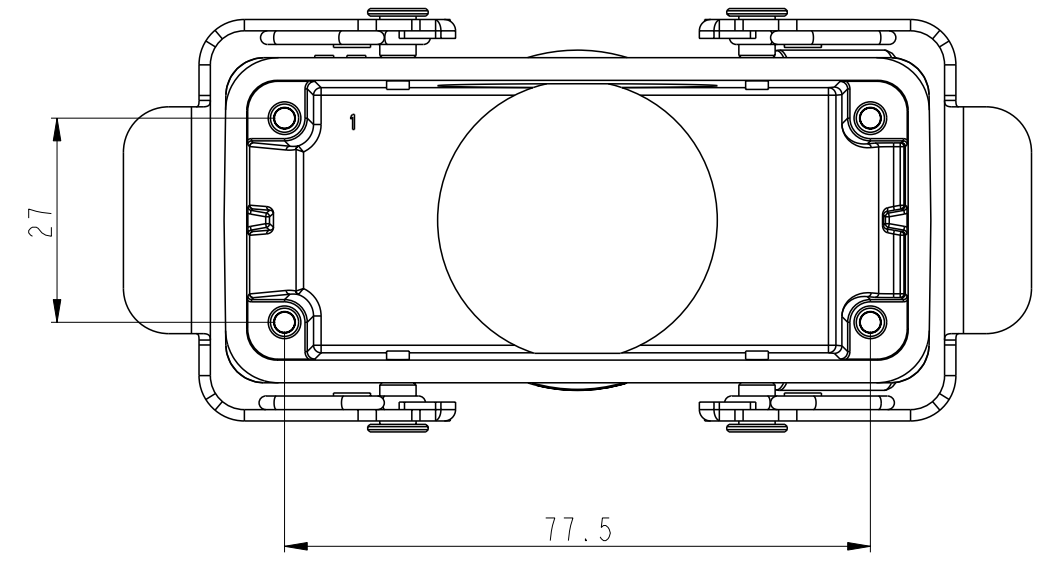
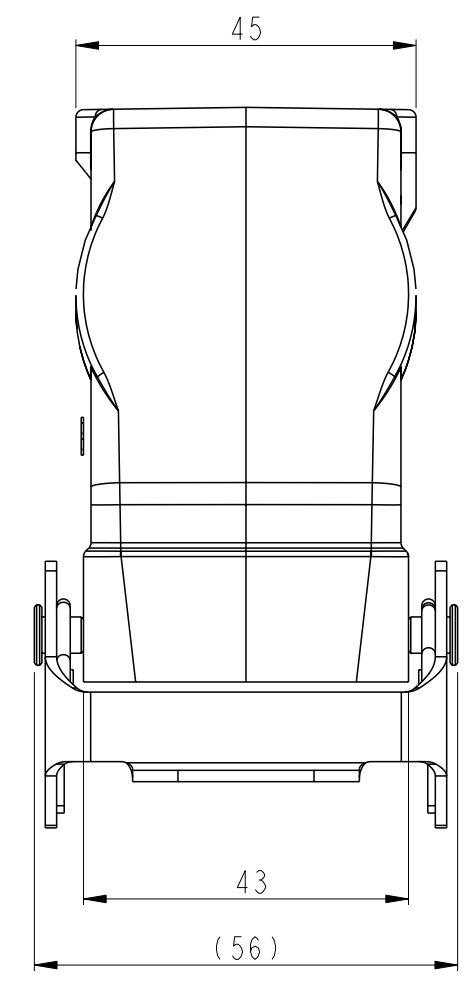
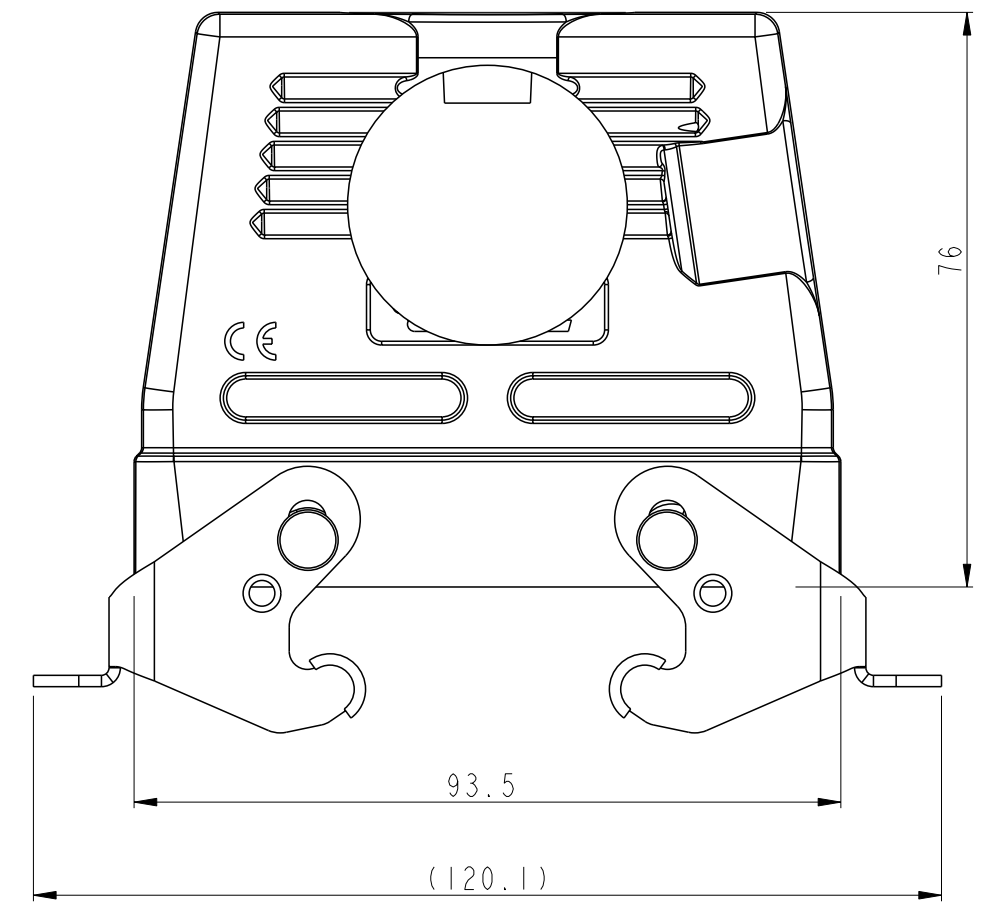

PG/M THREAD 2
PG/M 螺纹孔2

PG/M THREAD 1
PG/M 螺纹孔1

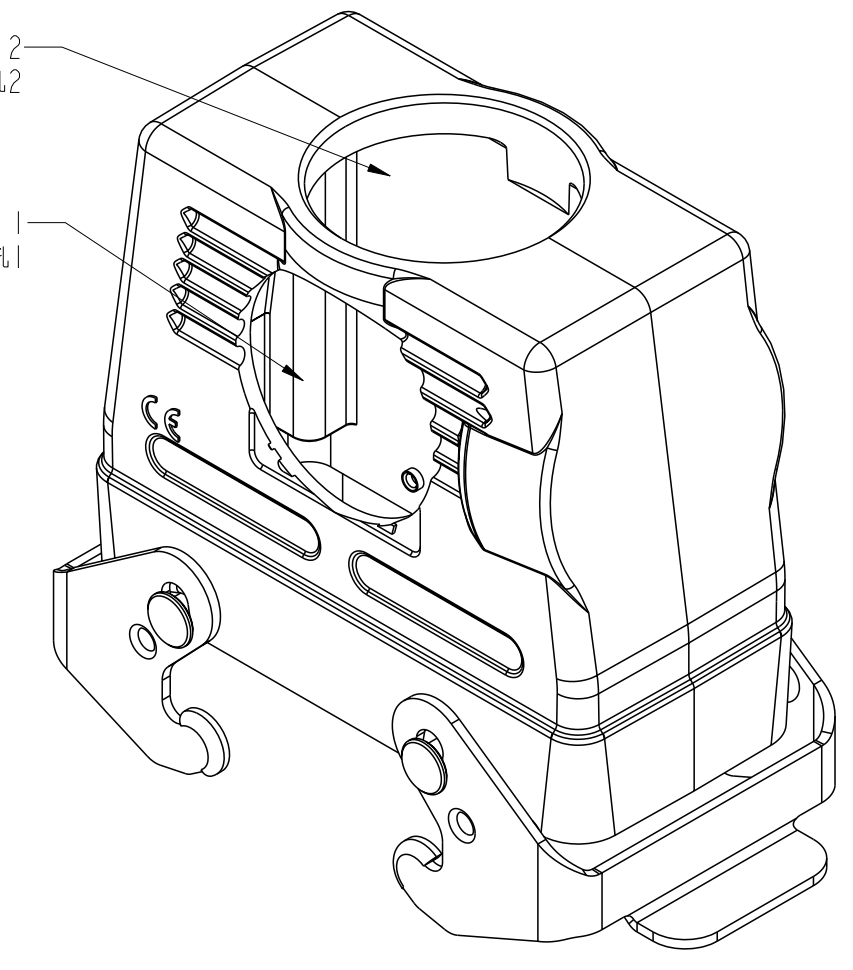

TYPE 5: HIGH CONSTRUCTION, TOP & FRONT ENTRY WITH STEEL DOUBLE LOCKING
 OTHER SPEC REFER TO TYPE 4
 类型5: 高结构, 顶出和前出, 带彩锌双扣, 其它规格参照类型4

T1290162929-000	HI6B-TGBH/TFBH-PG29/PG29	HI6B HOOD, TOP AND FRONT ENTRY PG29, METAL DOUBLE LOCKING, HIGH CONSTRUCTION, POWDER COATED, GREY HI6B上壳, 顶出和前出PG29, 彩锌双扣, 高结构, 灰色粉末喷涂	PG29	PG29	TYPE5 类型5
PART NUMBER 料号	PART DESCRIPTION 描述		PG/M THREAD 1 PG/M 螺纹孔1	PG/M THREAD 2 PG/M 螺纹孔2	TYPE 类型

THIS DRAWING IS A CONTROLLED DOCUMENT.

DWN	01AUG2018	JEREMY.ZHANG
CHK	01AUG2018	GINO.WANG
APVD	01AUG2018	CHRIS.WANG
PRODUCT SPEC	108-137013	
APPLICATION SPEC	114-137013	
WEIGHT	-	
Customer Drawing		

TE Connectivity

NAME HI6B-TSB/TGB/TGBH/TSBH/TFBH-M/PG

SIZE	CAGE CODE	DRAWING NO	RESTRICTED TO
A2	00779	G-T12X01621XX000	-
SCALE	1:1	SHEET	3 OF 3
REV	B1		

printed on 2 Jul 2021 11:06 (China Standard Time) from TE343646