

PRODUCT NUMBER	PLATING OPT.
10120666-XXX	OPTION 1
10120666-XXXLF	OPTION 2

PART NUMBER DESCRIPTION

10120666 - X 0 1 LF

BASE NUMBER HOUSING COLOR:
1: BLACK
3: NATURAL

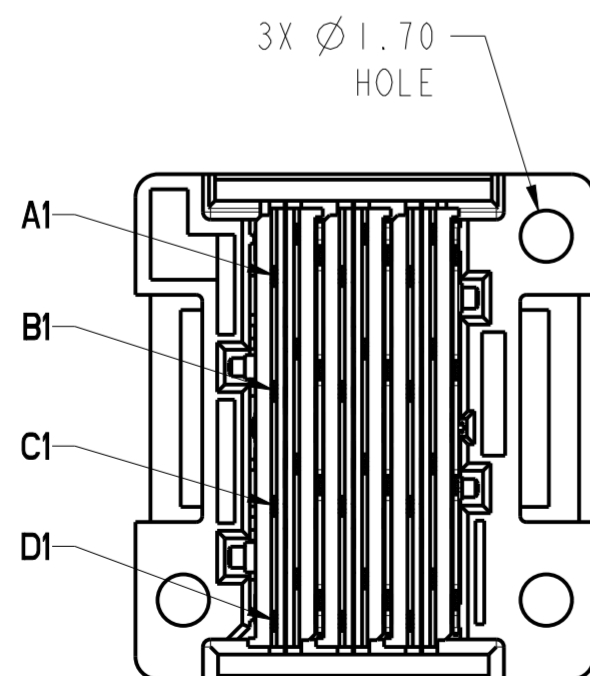
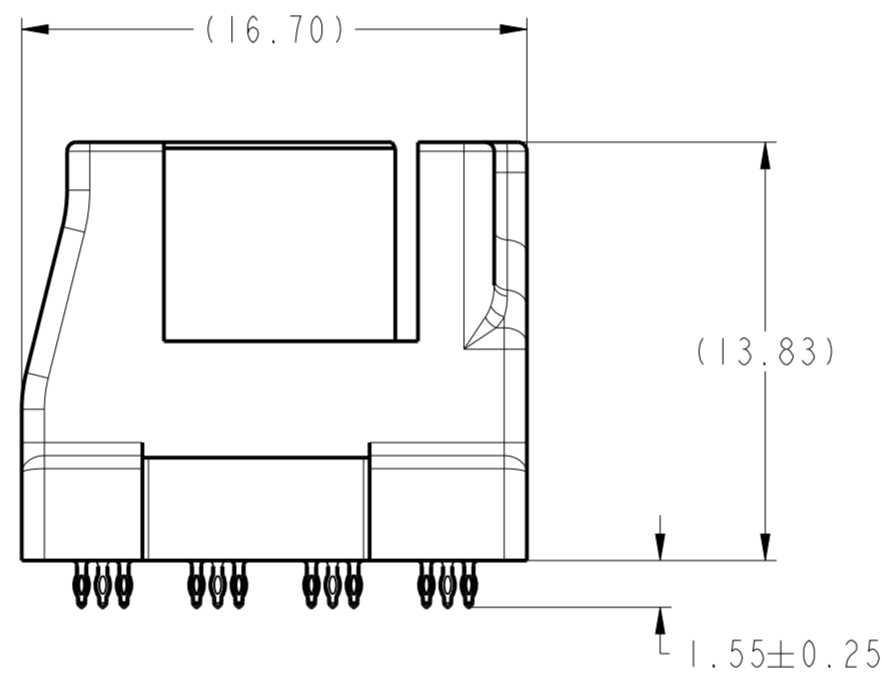
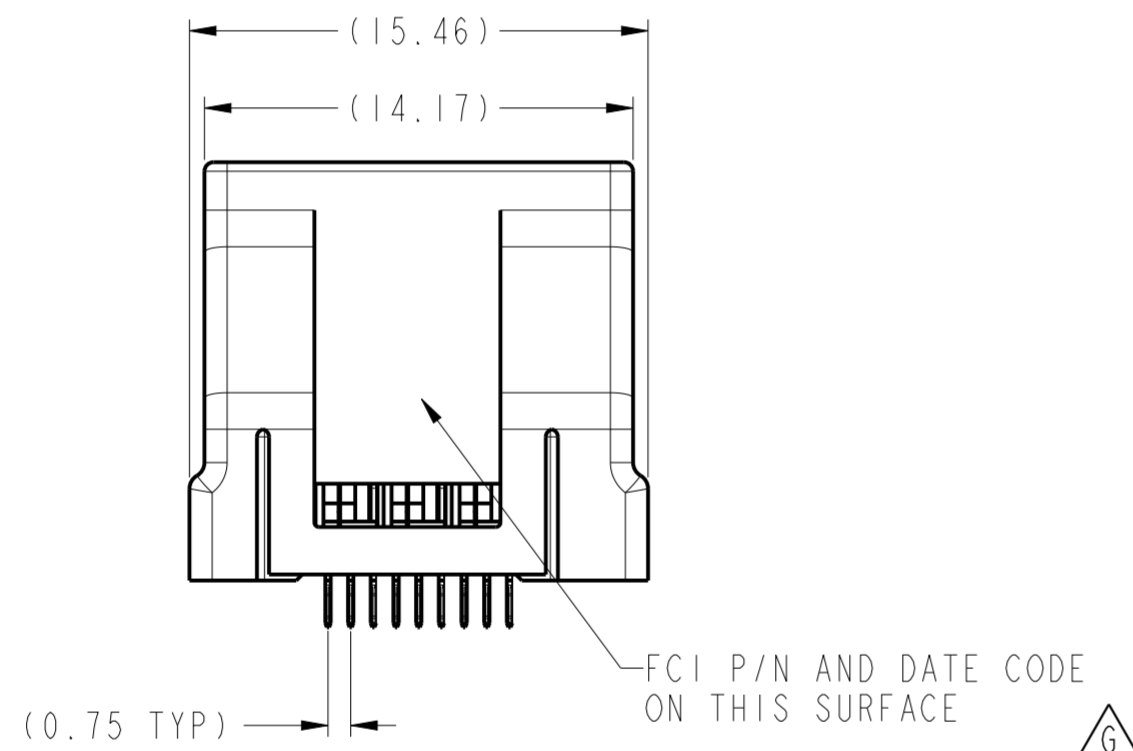
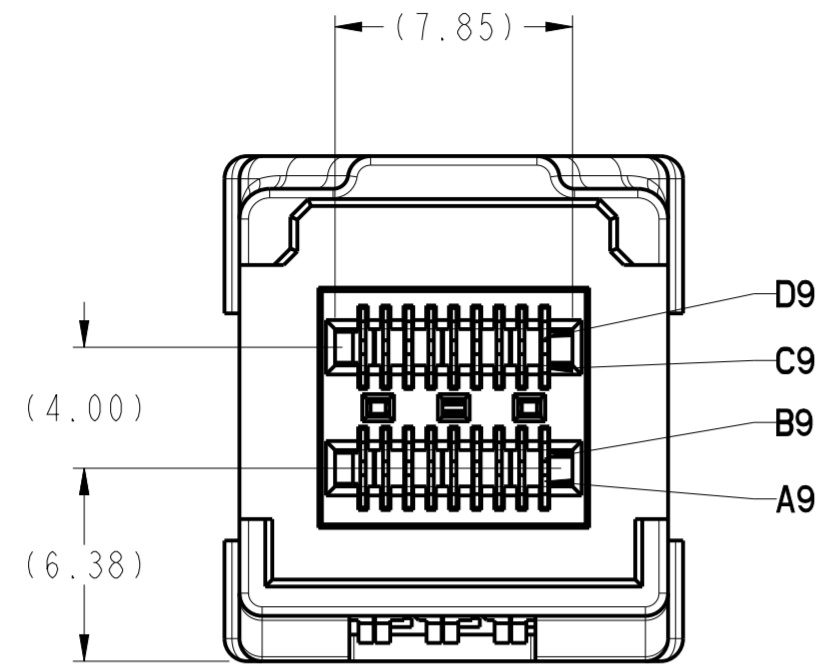
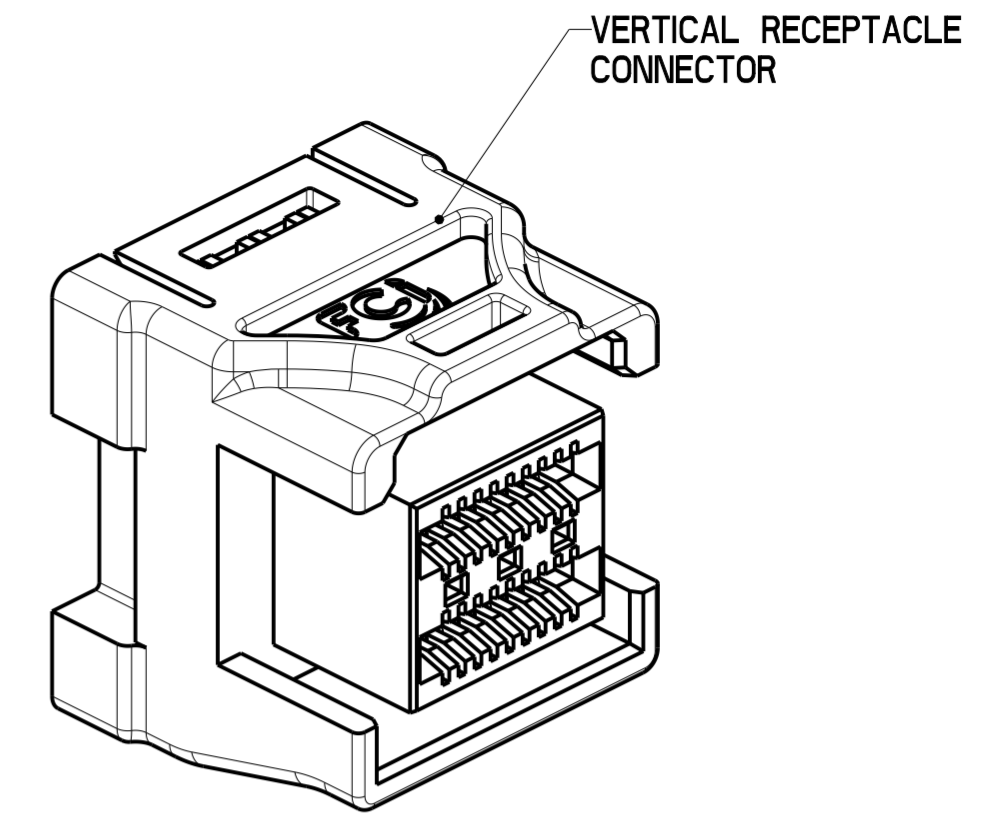

NOTES:

- CONNECTOR HOUSING: HIGH TEMPERATURE THERMOPLASTIC GLASS FILLED, UL 94V-0
TERMINALS: COPPER ALLOY
- FINISHES:
CONTACT AREA: 0.76um GOLD OVER 2.54 um MIN NICKEL WITH PAO LUBE.
TAIL AREA:
OPTION 1: 0.76um - 1.52um TIN/LEAD (90/10) OVER 2.54um MIN NICKEL.
OPTION 2: 0.76um - 1.52um TIN (LEAD FREE) OVER 2.54um MIN NICKEL.
- PRODUCT SPECIFICATION: GS-12-650
APPLICATION SPECIFICATION: GS-20-0356
PACKING SPECIFICATION: GS-14-1490
- MOUNTING HARDWARE:
OPTION 1: M2 X 0.91 SELF-THREADING SCREW
OPTION 2: M2 X 0.80 SELF-THREADING SCREW
MOUNTING SCREW LENGTH: PCB THICKNESS + (2.5±0.35)mm. G
- THIS CONNECTOR IS DESIGNED TO MEET THE REQUIREMENT OF INDUSTRY SPECIFICATION SFF-8643.

spec ref	-	dr	Deborah Ingram	2012/04/10	projection	MM	size	A2	scale	4:1
tolerance std	ASME Y14.5	eng	Jacklin Zou	2015/12/09			ecn no	ELX-DG-22744-1		
	TOLERANCES UNLESS OTHERWISE SPECIFIED	chr	Zhen Luo	2015/12/22			rel level	Released		
surface	✓	appr	Pei-Ming Zheng	2015/12/23	product family			title	IXI INTERNAL VERTICAL ASSEMBLY	
ASME Y14.5	linear			cat. no.	www.fci.com		dwg no	10120666		
	0.X ±0.25			Product - Customer Drw		sheet 1 of 4	rev	G		
	0.XX ±0.13			STATUS: Released		Printed: 30 Jan 04, 2016				
	0.XXX ±-			PDS: Rev : G						
	angular	0°	±1/2°							

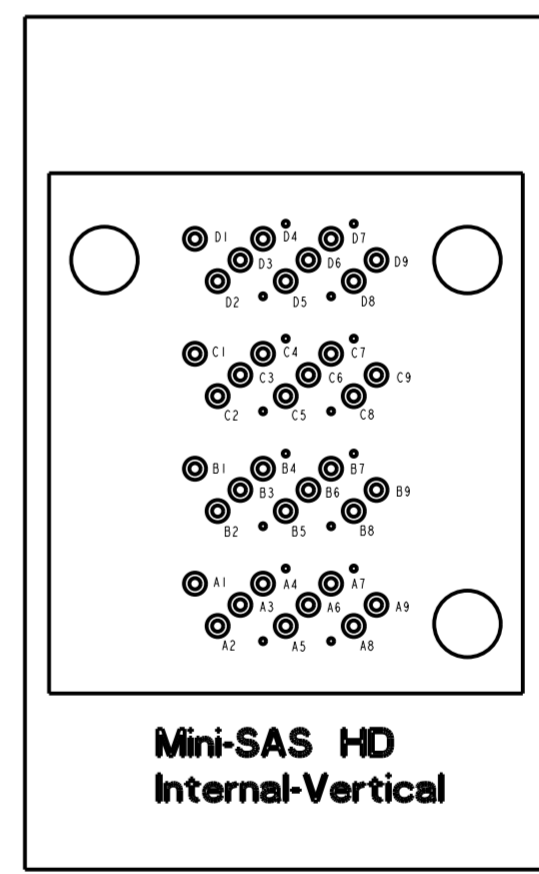
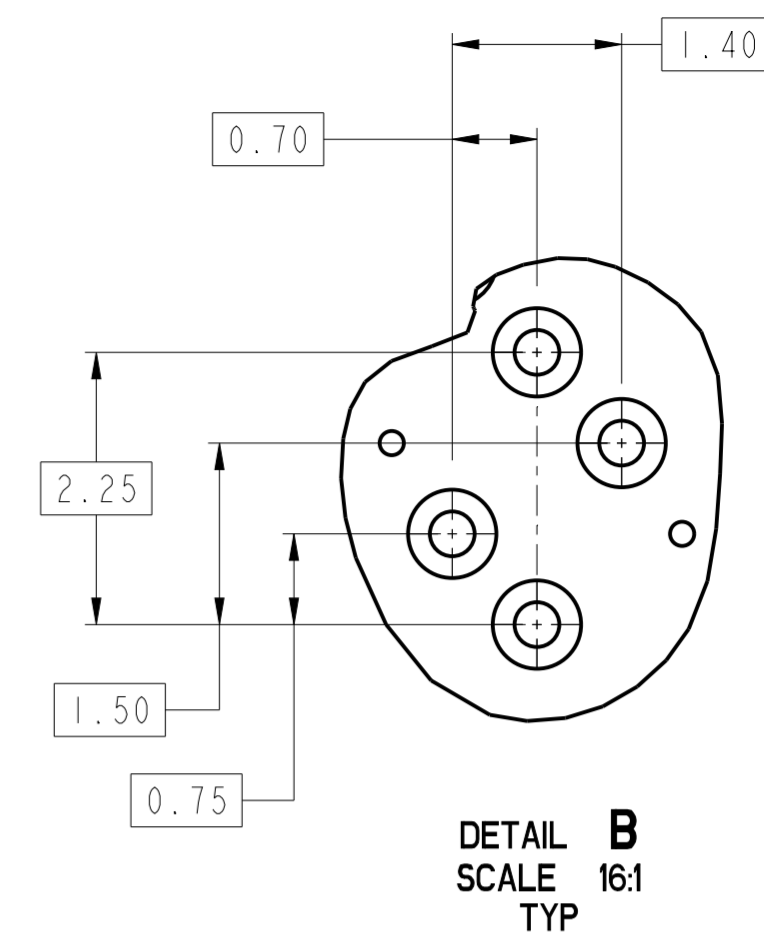
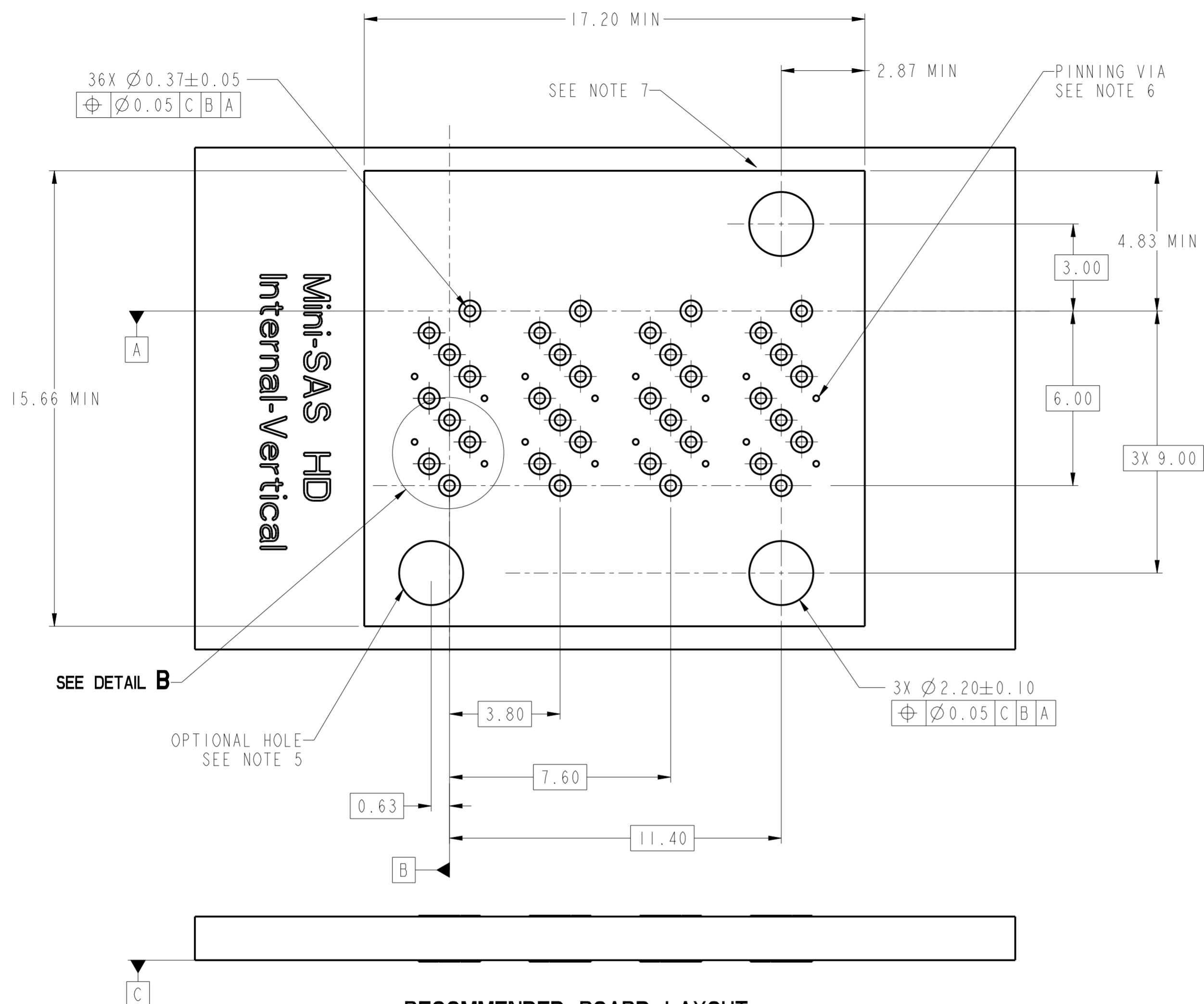

RECOMMENDED BOARD LAYOUT
SCALE 8:1

NOTES:

1. RECOMMENDED DRILL SIZE FOR A $\varnothing 0.37$ FINISHED PTH IS $\varnothing 0.457$ (#77 DRILL).
2. RECOMMENDED ANNULAR RING AROUND $\varnothing 0.37$ FINISHED PTH IS $\varnothing 0.73$.
3. MINIMUM RECOMMENDED SPACING : 14.00mm.
4. MINIMUM PCB THICKNESS : 1.57mm.
5. USE OF HOLE IS OPTIONAL AND CAN BE ADDED WHEN ADDITIONAL MECHANICAL MOUNTING AND STRAIN RELIEF IS DEEMED NECESSARY.
6. DETAILED INFORMATION OF "PINNING VIA" REFER TO APPLICATION SPECIFICATION GS-20-0356 SECTION 5
7. CONNECTOR KEEP OUT AREA

spec ref	-	dr	Deborah Ingram	2012/04/10	projection	MM	size	A2	scale	4:1
tolerance std	ASME Y14.5	eng	Jacklin Zou	2015/12/09	product family		ecn no	ELX-DG-22744-1	rel level	Released
surface	✓	chr	Zhen Luo	2015/12/22	cat. no.		dwg no	10120666	rev	G
ASME Y14.5	linear	0.X	±0.25	www.fci.com	Product - Customer Drw		sheet 2 of 4			
	angular	0°	±1/2°							

Copyright FCI. FCI

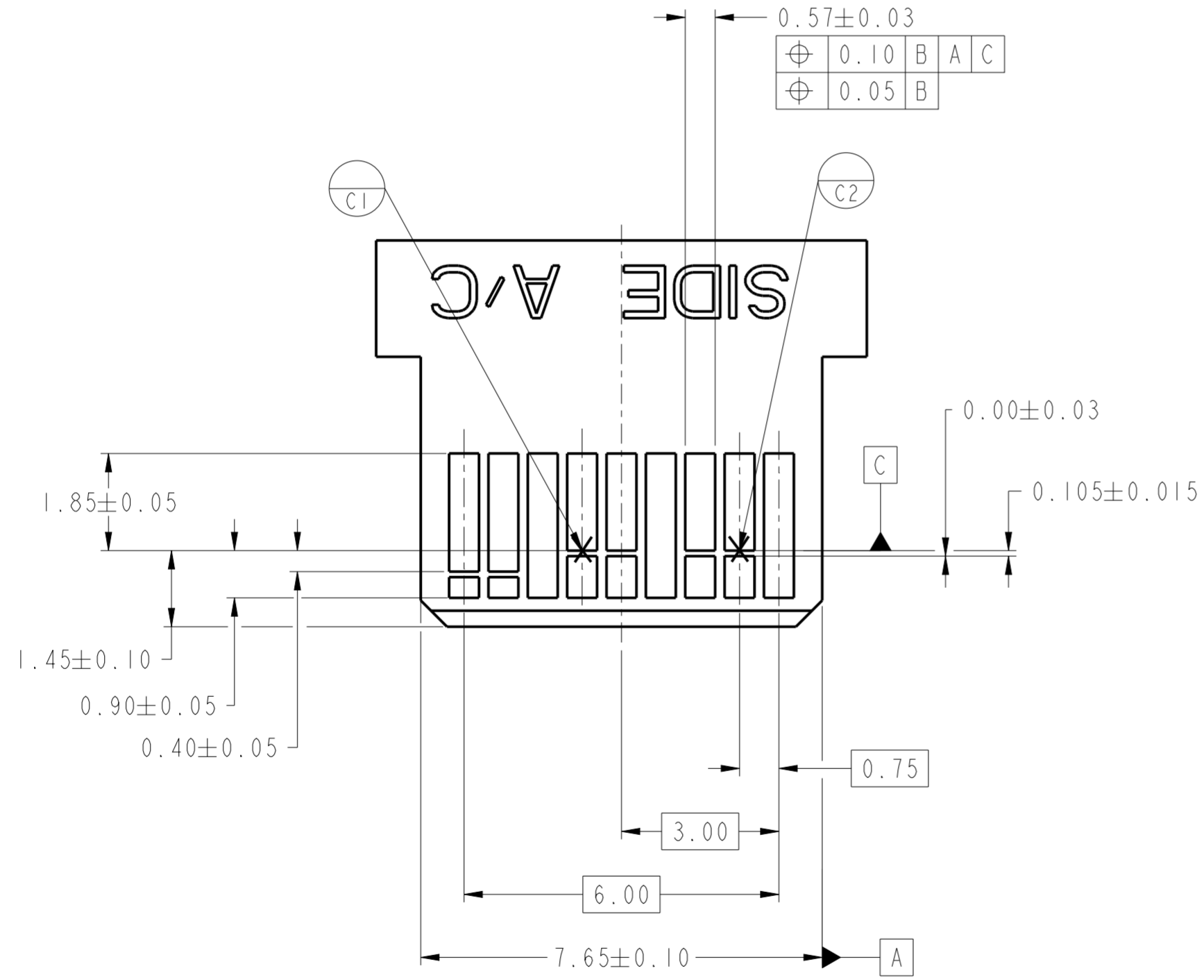
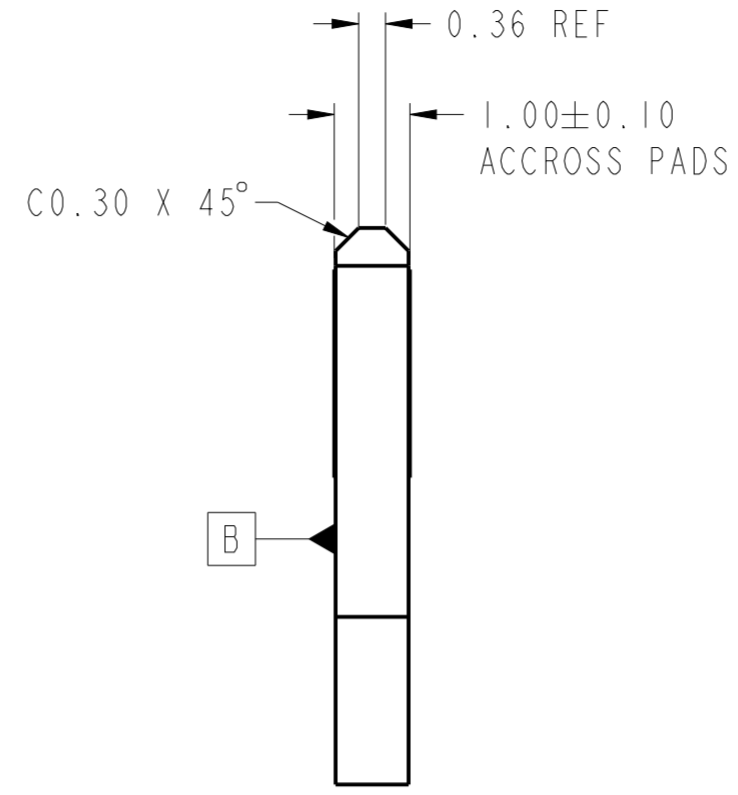
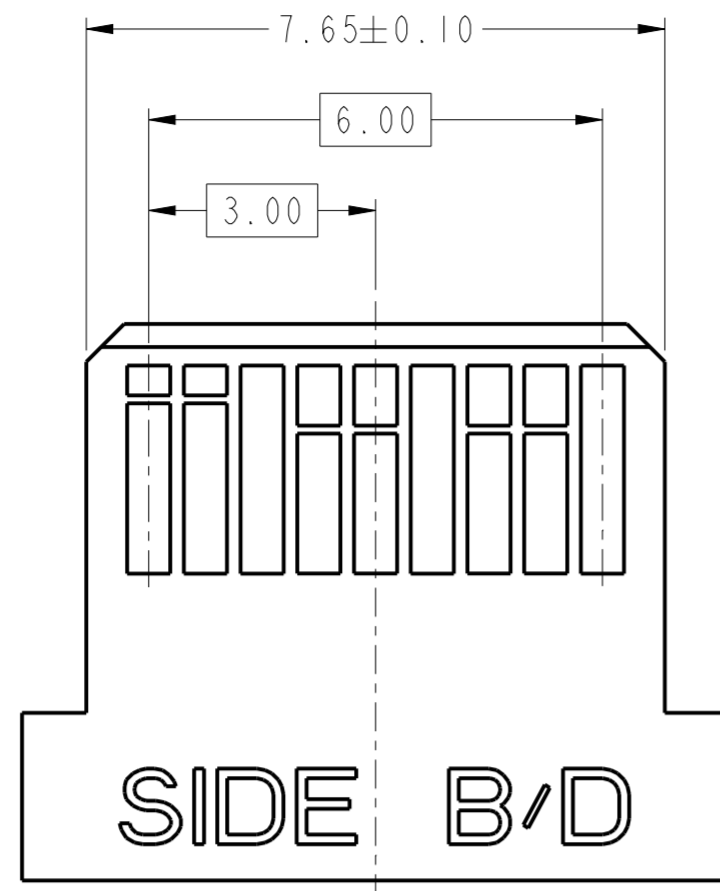

- NOTES:
- 0.05 MINIMUM KEEP OUT SOLDER MASK AROUND ALL PADS.
 - DATUM C TARGETS ARE DEFINED BY THE RESPECTIVE PAD CENTER LINES AND THE LEADING EDGE OF THE TARGET PADS.

spec ref	-	dr	Deborah Ingram	2012/04/10	projection	MM	size	A2	scale	4:1		
tolerance std	ASME Y14.5	eng	Jacklin Zou	2015/12/09			ecn no	ELX-DG-22744-1				
		chr	Zhen Luo	2015/12/22			rel level	Released				
		appr	Pei-Ming Zheng	2015/12/23	product family							
surface	✓	linear	0.X	±0.25		IXI INTERNAL VERTICAL ASSEMBLY MINI-SAS HD CONCEPT	dwg no 10120666	rev G	ASME Y14.5 angular 0° ±1/2°			
			0.XX	±0.13					www.fci.com	cat. no.	Product - Customer Drw	sheet 3 of 4
			0.XXX	±								

Copyright FCI. FCI

1 2 3 4 5 6 7 8

A B C D E F

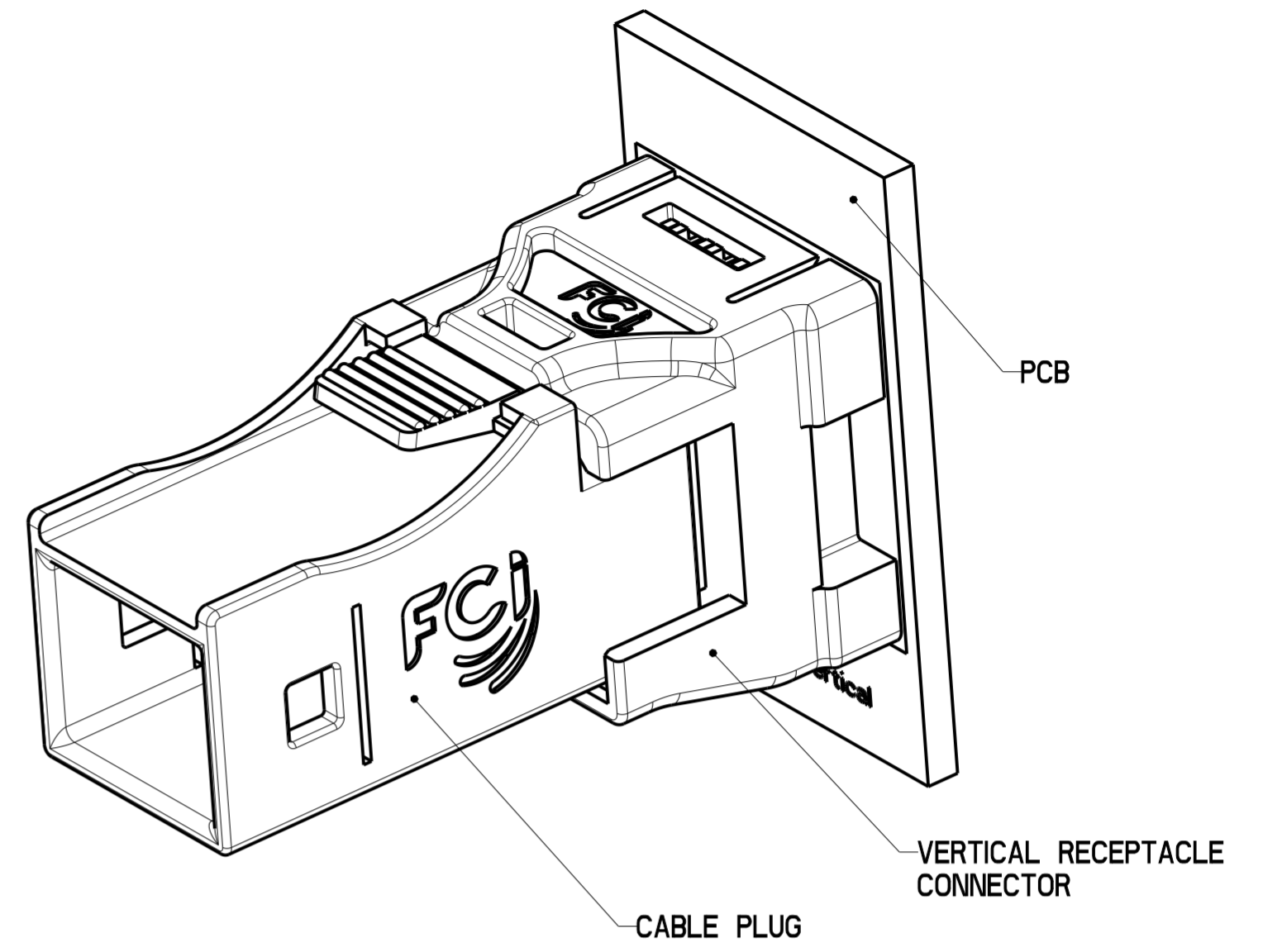
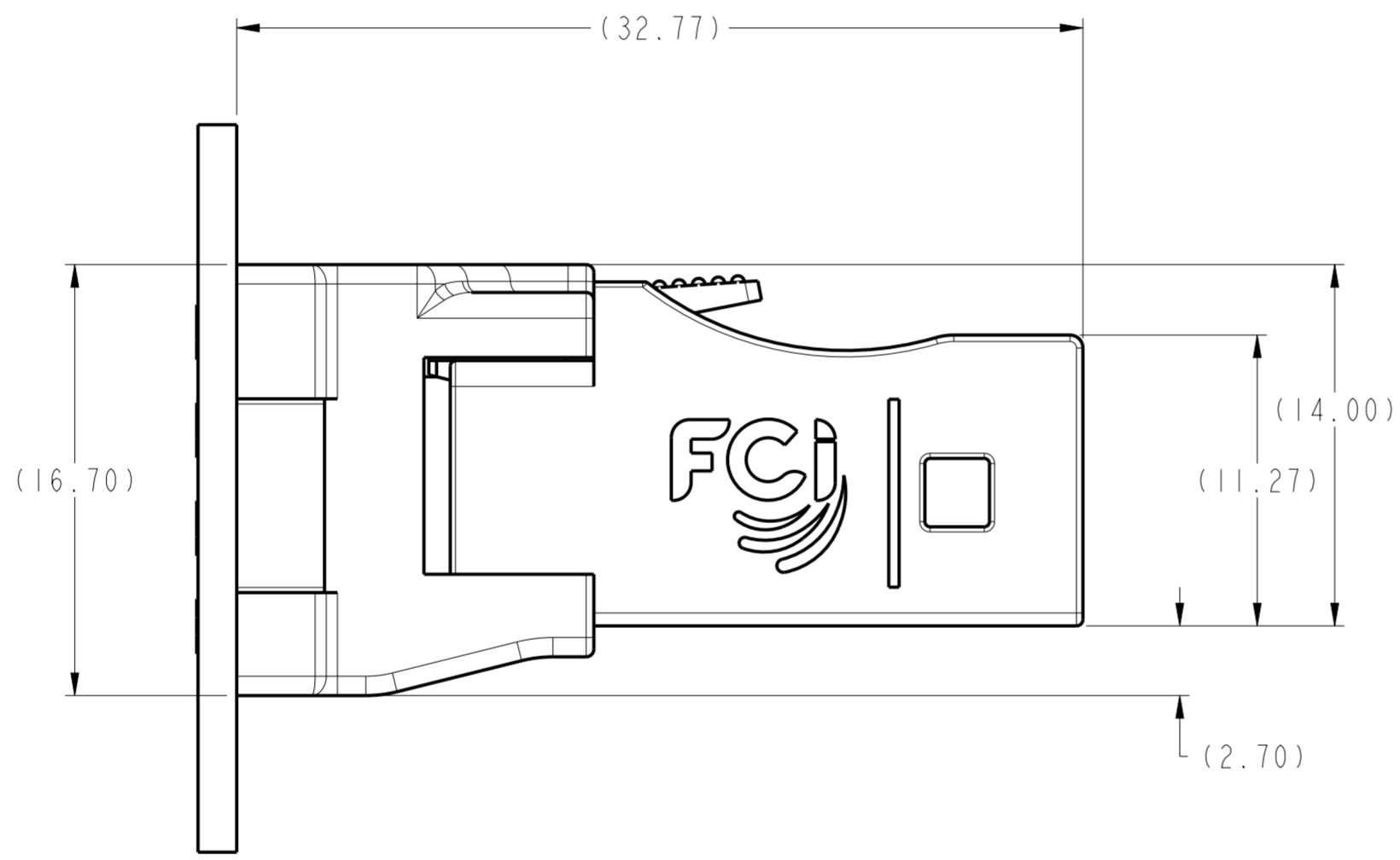

Copyright FCI. FCI

spec ref	-	dr	Deborah Ingram	2012/04/10	projection	MM	size	A2	scale	4:1	
tolerance std	ASME Y14.5	eng	Jacklin Zou	2015/12/09			ecn no	ELX-DG-22744-1			
		chr	Zhen Luo	2015/12/22			rel level	Released			
		appr	Pei-Ming Zheng	2015/12/23	product family						
surface	✓	linear	0.X	±0.25		TITLE IXI INTERNAL VERTICAL ASSEMBLY MINI-SAS HD CONCEPT www.fci.com	dwg no	10120666		rev	G
			0.XX	±0.13			cat. no.	Product - Customer Drw		sheet 4 of 4	
		angular	0°	±1/2°							