

**Features:**

- Universal AC input/ Full range
- Built-in active PFC function, PF>0.95
- Miniature Size, High Efficiency, and High Reliability
- Output Protections: OLP/OVP/OPP/OTP/SCP
- Withstand 300VAC Surge Input for 5 Sec
- Suitable for critical applications
- Wide operating ambient temperature (-20°C~70°C)
- PCB soldering side with conformal coating
- All using 105°C long life electrolytic capacitors.
- 100% full load burn-in test



Model	QGKF-150-12	QGKF-150-15	QGKF-150-24	QGKF-150-48
Output Characteristics				
DC Output	12V	15V	24V	48V
Rated Current	12.5A	10.0A	6.3A	3.2A
Current Range (Note 1)	0~12.5A	0~10.0A	0~6.3A	0~3.2A
Ripple and Noise (Note 2)	0~70°C	≤100mV	≤100mV	≤100mV
	-20~0°C	≤200mV	≤200mV	≤200mV
Voltage ADJ. Range	10.8V~13.2V	13.5V~16.5V	21.6V~26.4V	43.2V~52.8V
Voltage Accuracy	±2.0%	±2.0%	±2.0%	±2.0%
Line Regulation	±0.5%	±0.5%	±0.5%	±0.5%
Load Regulation	±2.0%	±2.0%	±1.0%	±1.0%
Set-up Time	≤3.0s (115VAC input, full load) ≤2.0s (230VAC input, full load)			
Hold-up Time	≥10ms (230VAC input, full load)			
Temperature Coefficient	±0.03%/°C			
Overshoot and Undershoot	<5.0%			
Input Characteristics				
Voltage Range	90VAC~264VAC			
Frequency Range	47Hz~63Hz			
Power Factor (Typical)	PF>0.98/115VAC PF>0.95/230VAC			
Efficiency (Typical) 230VAC Input	86%	87%	87%	88%
AC Current (max)	<2.0A			
Inrush Current (Typical)	<30A@115VAC Cold start <45A@230VAC Cold start			
Leakage Current	Input-Output: <0.25mA Input-PG: <3.5mA			
Protection				
Over Load (OLP)	105%~150% of rated output current, hiccup mode, auto recovery			
Over Power (OPP)	105%~150% of rated output power, hiccup mode, auto recovery			
Over Voltage (OVP)	115%~150% of rated output voltage, hiccup mode, auto recovery			
Over Temperature (OTP)	105°C ± 5°C(detect from Mosfet temp); shutdown, auto recovery after the temperature decreases to 60°C			
Short Circuit (SCP)	Long-term mode, auto recovery			
Environmental Characteristics				
Operating Amb. Temp. & Hum	-20°C~70°C; 20%~90% RH Non-Condensing			
Storage Temp. & Hum	-30°C~85°C: 10%-95% RH Non-Condensing			
Safety Standards	UL60950-1 2nd Ed; IEC 60950-1:2005(2nd Ed); EN60950-1: 2006			
Withstand Voltage	Primary-Secondary: 3.0KVAC;≤10mA. Primary-PG: 1.5KVAC;≤10mA. Secondary-PG: 0.5KVDC;≤10mA			
Isolation Resistance	100M ohms			
EMI Conduction & Radiation	Compliance to EN55022 Class B			
Harmonic Current	Compliance to EN61000-3-2, Class A			
EMS Immunity	Compliance to EN61000-4-2, 3, 4, 5, 6, 8, 11; heavy industry level			
General Characteristics				
MTBF (MIL-HDBK-217F)	More than 200,000Hrs (25°C, Full load)			
Dimension (LxWxH)	160x98.3x38mm			
Packing	20PCS/CTN. G.W: 14kgs			
Cooling Method	Cooling by free air convection			
Note	1. All parameters NOT specially mentioned are measured at rated input, rated load, and 25°C of ambient temperature 2. Measured at 20MHz of bandwidth by using a 12" Twisted pair wire terminated with a 0.1uF & 47uF parallel capacitor 3. The SPS is considered a component which will be installed into final equipment. The equipment must be re-confirmed that it still meets EMC directives.			

MECHANICAL SPECIFICATIONS

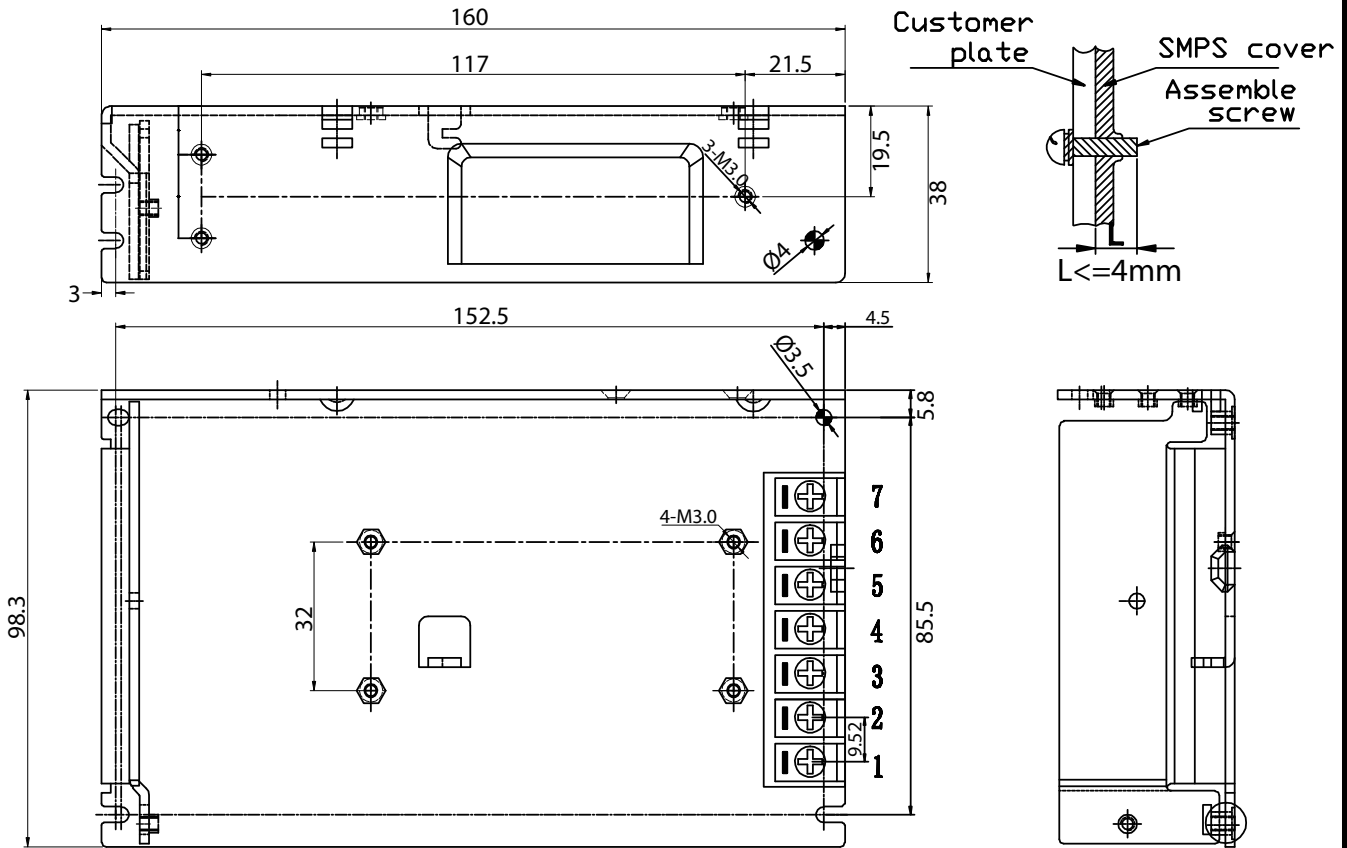

Pin No.	Assignment
1	AC-L
2	AC-N
3	F.G
4,5	DC output -V
6,7	DC output +V

DERATING CURVE

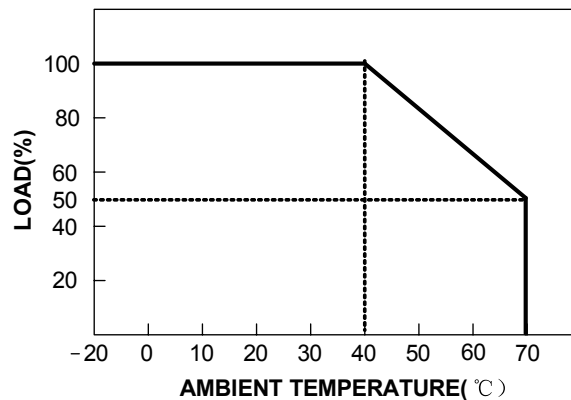

UNIT: mm