

Model

LS700-RH

RoHS COMPLIANT

12 Volt Input

Dual Tube CCFT Inverter (8W)

Brightness Control (PWM Dimming 20-100%)

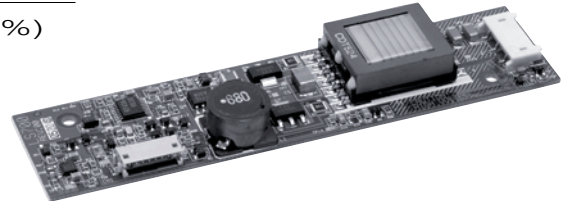

Physical Specifications

Dimensions:	25mm x 105mm x 10mm (0.98" x 4.13" x 0.39")
Operating Temp:	0 to 60°C, convection cooling
Relative Humidity:	20% to 90%, non-condensing
Storage:	-20 to 80°C/5-95% RH
Impact Resistance:	50G half wave per 2 msec
Vibration Resistance:	10-55-10 Hz/min @ 1.5mm

Input Specifications*

Item	Condition	Standard		
		MIN	TYP	MAX
Input Voltage Rated Tolerance	—	12 Vdc		
	Continuous Operation Starting Condition (Discharge Starting Voltage)	10.8 Vdc - 13.2 Vdc		
Max. Input Current	V _{IN} = 10.8 Vdc Luminance @ Max.	1.0 A		
Max. Input Power	V _{IN} = 12 Vdc Luminance @ Max.	12 W		
On/Off Input Current	On V _{CONT} = 2.0-Vcc Vdc	I _{MAX} = 4.0 mA		
	Off V _{CONT} = 0.3-0.8 Vdc	I _{MAX} = 50 µA		
DC-Bright	I _{OUT} = Max	3.8 V		
	I _{OUT} = Min	2.0 V		
PWM Bright Duty Ratio	t _{ON} / t _{BC} Max	1.00		
	t _{ON} / t _{BC} Min	0.30		
PWM Bright Pulse Frequency	1 / t _{BC}	400 Hz		
		380 ~ 420 Hz		

*Above Specifications Occur @ 25 ± 5°C

Output Specifications*

Item	Condition	Standard		
		MIN	TYP	MAX
Output Voltage (Vrms)	V _{IN} = 10.8 Vdc	1500	1650	—
Tube Current for 2 Lamps (mA _{rms})	Luminance @ Max. (V _{IN} = 12.0 Vdc)	10.4	12.0	13.6
	Luminance @ Min. (V _{IN} = 12.0 Vdc)	—	7.0	—
Max. Power Output for 2 Lamps (W)	V _{IN} = 12 Vdc/Luminance @ Max.	—	—	8.0
Ignition Frequency (kHz)	Luminance @ Max. (V _{IN} = 12.0 Vdc)	50	60	70

*Above specifications occur @ 25 ± 5°C & V_{IN} = 10.8 - 13.2 Vdc.

Model

LS700-RH

Luminance Variance* (DC Bias Control)

Item	Condition	Applied Voltage	Output Current
Luminance @ Max.	Btwn. pin 4 & 6	Vcont = 3.8 V	12.0 mA (2 lamps)
Luminance @ Min.	Btwn. pin 4 & 6	Vcont = 2.0 V	6.5 mA (2 lamps)

* Luminance can also be controlled by applying PWM signal to pin 5 (pin 4 must be connected to GND).

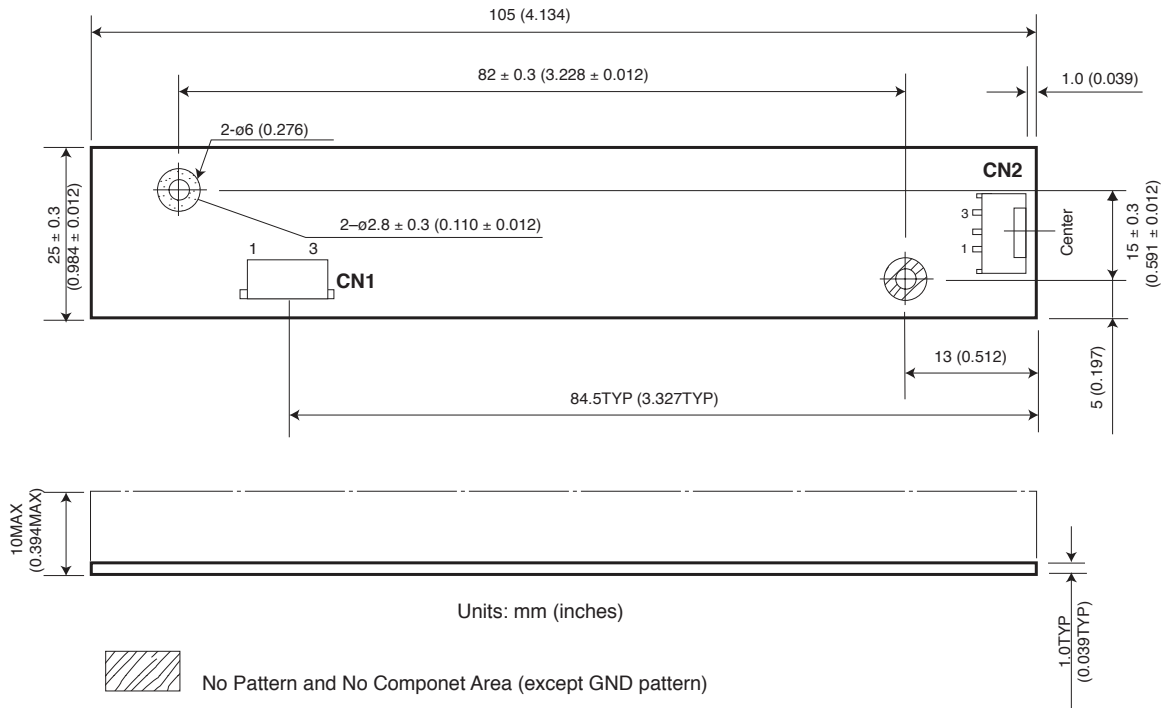

Units: mm (inches)

 No Pattern and No Component Area (except GND pattern)

 GND Pattern Area

CN1 Input Connector

Hirose DF13-8P-1.25H
(pin number 1 is marked on PCB)

V(in)	1
V(in)	2
On/Off	3
Bright DC	4
Bright PWM	5
S-GNG	6
GND	7
GND	8

CN1 Corresponding Housing

Hirose DF13-8S-1.25C
(Hirose Connector Pin Numbers)

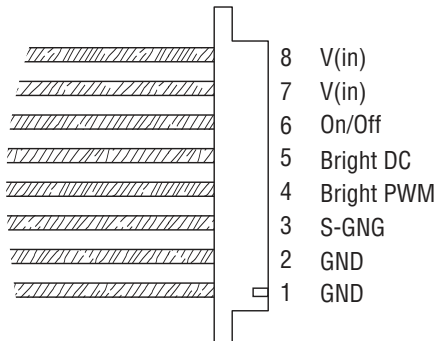

CN2 Output Connector

JST SMO3 (4.0) B-BHS-1-TB

CCFT LOW	1
CCFT HIGH	2
CCFT HIGH	3

CN2 Corresponding Housing

JST BHR-03VS-1

TAIYO YUDEN

TAIYO YUDEN (U.S.A.), INC.
440 Stevens Avenue, Suite 300 Solana Beach, CA 92075
(858) 350-6800 / Fax: (858) 350-6854
(800) 263-4532 www.t-yuden.com inverters@t-yuden.com



Model

LS700-RH

Tech Notes

Connection Diagram

LS700A-RH

DC Bright Control Connection

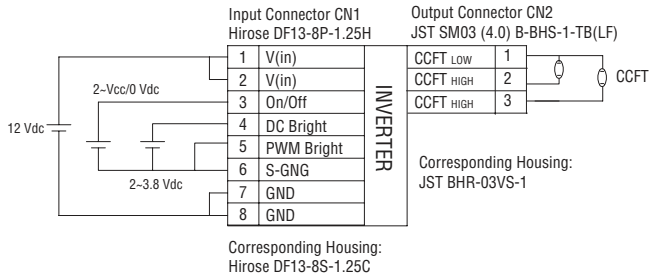

PWM Bright Control Connection

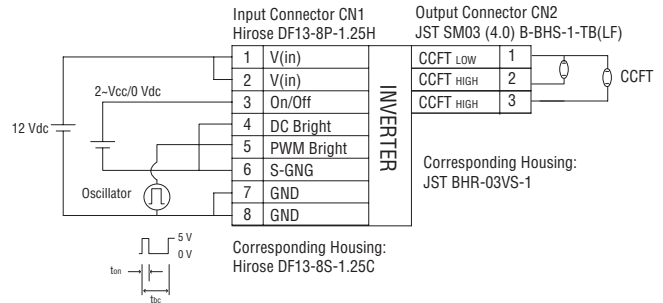

DC Bright Control Method*

Maximum output current can be adjusted by applying bias voltage between brightness control pins as shown below.

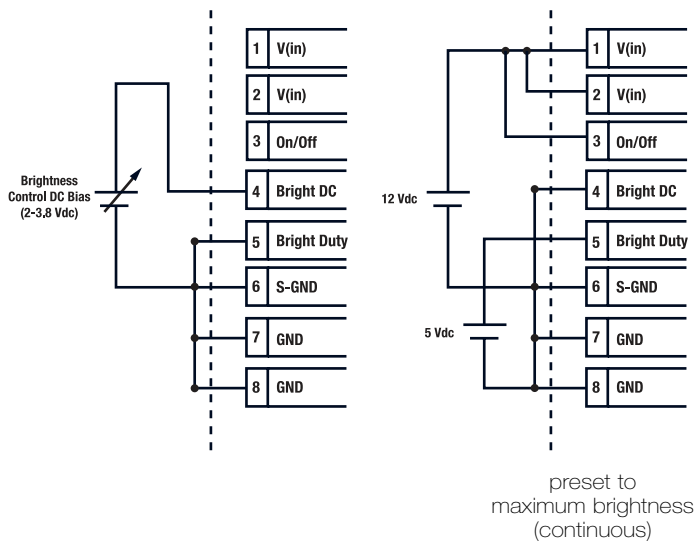

DC Bias	Lamp Current (2 lamps)
2.0 V	6.98 mA
2.2 V	7.89 mA
2.4 V	8.60 mA
2.6 V	9.22 mA
2.8 V	9.80 mA
3.0 V	10.40 mA
3.2 V	11.00 mA
3.4 V	11.72 mA
3.6 V	12.00 mA
3.8 V	12.00 mA
4.0 V	12.00 mA

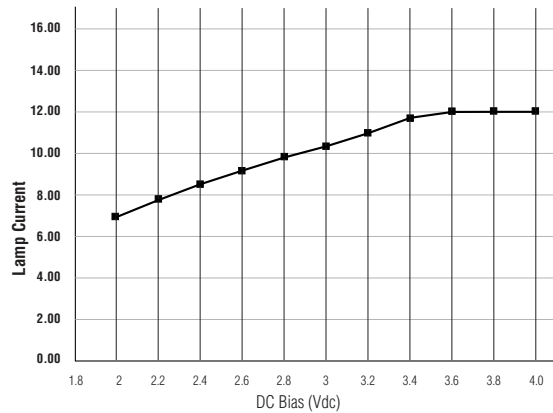

* Above specifications occur @ 25 ± 5°C, pin 5 connected to GND, and V_{IN} = 12 Vdc using Mitsubishi AA121SK panel.

On/Off Control

The inverter is ON if one of the following conditions are met:

- Pin 3 (On/Off) is connected to pin 1/2 (V_{IN})
- Pin 3 (On/Off) = 2 Vdc — 13.2 Vdc

The inverter is OFF if one of the following conditions are met:

- Pin 3 (On/Off) is connected to pin 7/8 (GND)
- Pin 3 (On/Off) ≤ 0.8 Vdc

© Copyright 2007 TAIYO YUDEN (U.S.A.), INC. Specifications subject to change without notice.



TAIYO YUDEN (U.S.A.), INC.
 440 Stevens Avenue, Suite 300 Solana Beach, CA 92075
 (858) 350-6800 / Fax: (858) 350-6854
(800) 263-4532 www.t-yuden.com inverters@t-yuden.com

