

Product Specification for Approval

WE ARE PLEASED IN SUBMITTING OUR SAMPLES WITH SPECIFICATION TO YOU FOR APPROVAL.

CUSTOMER	:		
DESCRIPTION	:	10/100 BASE-T TRANSFORMER	
MNC P/N	:	H1631CG	
VERSION	:	A0	
CUSTOMER P/N	:		
ISSUED DATE	:	2020/04/27	
PHOTO OF PRODUCT	:		
WEIGHT	:		0.28g
MADE IN	:		CHINA

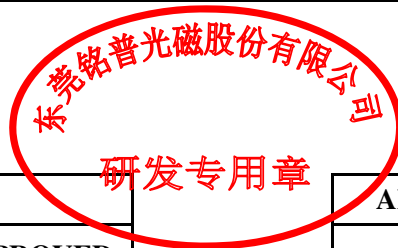

APPROVED BY MNC			APPROVED BY CUSTOMER
PREPARED BY	CHECKED BY	APPROVED BY	SIGNATURE OR STAMP
研发部 2020-04-27 符晶晶	研发部 2020-04-27 肖明华	研发部 2020-04-27 何校民	

1. PLEASE SEND BACK US A COPY OF THE SPECIFICATION WITH YOUR STAMP OR SIGNATURE ONCE THE SAMPLES APPROVED.
2. IT WILL BE DEEMED THE SAMPLES TO BE APPROVED IF NO FEEDBACK.

东莞铭普光磁股份有限公司
 Add: Shipai Town, Dongguan City, Guangdong Province, China

TEL: +86-769-86921000
 FAX: +86-769-81701563

HISTORY FOR REVISED SPECIFICATION**Part No. H1631CG****INDEX**

1. INDEX-----	1
2. CHANGE RECORD-----	1
3. MECHANICAL-----	2
4. SCHEMATIC-----	3
5. PACKING-----	4
6. MATERIAL LIST-----	5
7. RECOMMENDED SOLDERING PROFILE-----	6

CHANGE RECORD

REV.	DESCRIPTION (Content or Reason For Change)	DATE	REVISOR
A0	INITIAL RELEASE	2020-04-27	Jingjing Fu

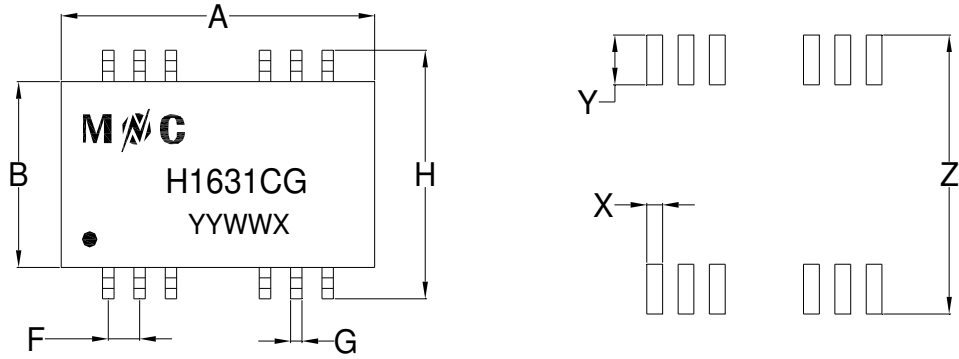
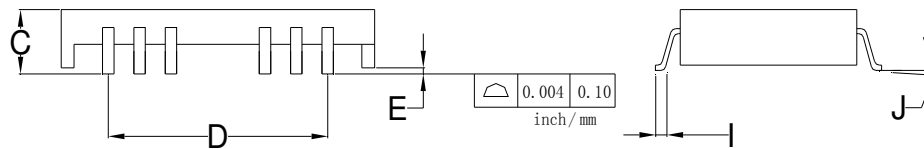
SPECIFICATION
Part No. H1631CG
A. MECHANICAL :

SUGGESTED PAD LAYOUT

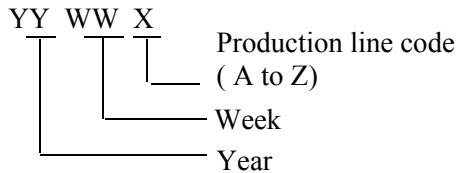
Note: Laser printing marking

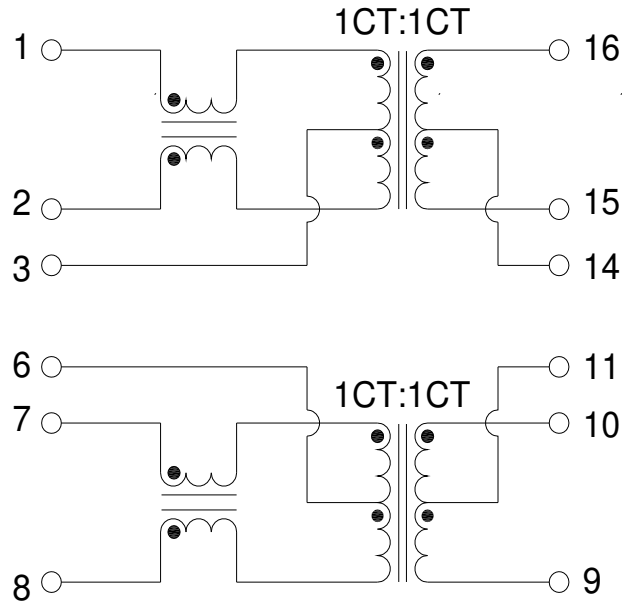

1. UNITS: mm/inch.
2. UNLESS OTHERWISE SPECIFIED ALL TOLERANCES ARE: TYPICAL
3. PIN LENGTH DON'T INCLUDE SOLDER POINT
4. CUT OFF PIN4,5,12,13

DIM	MILLIMETERS			INCHES		
	MIN	NOM	MAX	MIN	NOM	MAX
A	12.20	12.70	13.20	0.480	0.500	0.520
B	6.60	7.10	7.60	0.260	0.280	0.299
C	/	/	2.50	/	/	0.098
D	/	8.89	/	/	0.350	/
E	0.15	0.30	0.45	0.006	0.012	0.018
F	/	1.27	/	/	0.050	/
G	/	0.46	/	/	0.018	/
H	8.95	9.45	9.95	0.352	0.372	0.392
I	/	0.76	/	/	0.030	/
J	0°	/	8°	0°	/	8°
X	/	0.76	/	/	0.030	/
Y	/	1.91	/	/	0.075	/
Z	/	10.65	/	/	0.419	/

SPECIFICATION
Part No. H1631CG
B. SCHEMATIC :

C. ELECTRICAL SPECIFICATION @25°C

ITEM	SPECIFICATION	TEST CONDITION	TEST EQUIPMENT
INDUCTANCE :	350uH MIN.	100KHz 0.2V	TH2819XB OR EQU.
LEAKAGE INDUCTANCE :	0.50uH MAX.	100KHz 0.2V	TH2819XB OR EQU.
INTERWINDING CAPACITANCE :	25pF TYP.	100KHz 0.2V	TH2819XB OR EQU.
DC RESISTANCE :	1.2Ω MAX.	AT 25 °C	TOS 8020 OR EQU.
TURNS RATIO :	1CT:1CT±2%		TH2819XB OR EQU.
POLARITY :	1-16,7-10 IN-PHASE		
INSERTION LOSS :	-1.1dB MAX.	0.5-100 MHz	E5061A OR EQU.
RETURN LOSS :	-18dB MIN.	0.5-30 MHz	E5061A OR EQU.
	-18+20*log(f/30)dB MIN.	30.1-60MHz	
	-12dB MIN.	60.1-80MHz	
CROSS TALK :	-35dB MIN.	0.5-40 MHz	E5061A OR EQU.
	-33+20*log(f/50)dB MIN.	40.1-100 MHz	
CMRR :	-30dB MIN.	0.5-100 MHz	E5061A OR EQU.
ISOLATION HI-POT :PRI TO SEC	1500VAC	1mA,60S	7152AB OR EQU.
	1650VAC	1mA,6S	
OPERATING TEMPERATURE	0°C TO 70°C		

PACKAGE

Part No. H1631CG

D. PACKING:

a. PACKAGING AS BELOW (ONLY FOR A REFERENCE):

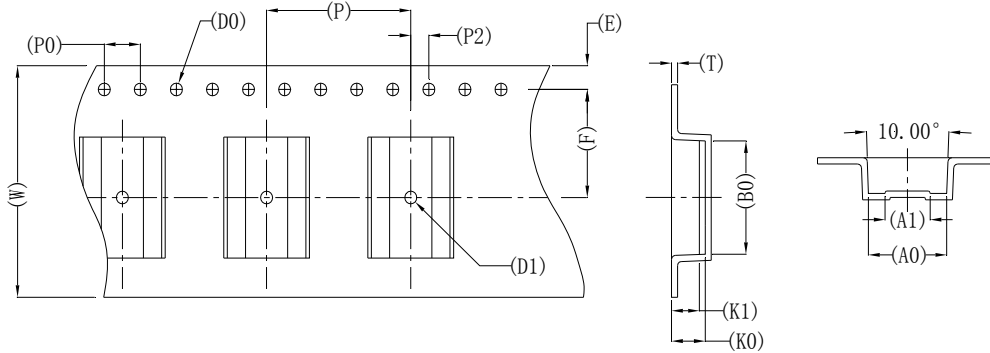

ITEM	W	A ₀	A ₁	B ₀	K ₀	K ₁	P	F	E	D ₀	D ₁	P ₀	P ₂	T
DIM	24.00 ^{+0.3} _{-0.3}	10.15±0.15	5.50±0.15	13.20±0.15	3.00±0.10	2.60±0.10	16.00±0.10	11.50±0.10	1.75±0.10	Φ1.50 ^{+0.10} _{-0.2}	Φ1.50MIN	4.00±0.10	2.00±0.05	0.30±0.05
ALTERNATE														

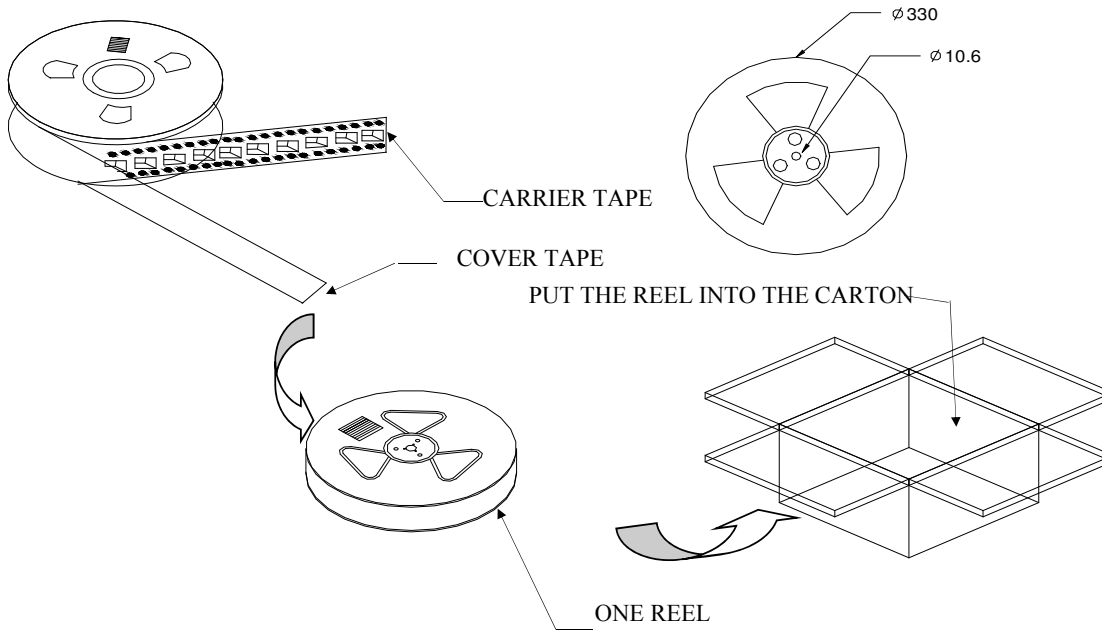

b. Q'TY:

1400 PCS PER REEL
7 REEL PER CARTON
9800 PCS PER CARTON

c. LABEL:



REMARK:

ABOVE PACKING IS FOR YOUR REFERENCE ONLY, WHICH MIGHT BE CHANGED WITHOUT NOTICE.

MATERIAL LIST
Part No. H1631CG
E.BOM

MATERIAL LIST					
NO.	ITEM	MATERIAL	RATING	SUPPLIER OF MATERIAL	UL
1	CORE	Mn-Zn	-----	YEAN SHING	N/A
			-----	ZHONGSHAN CRC ELECTRONICS FACTORY	N/A
		Ni-Zn	-----	YEAN SHING	N/A
			-----	ZHONGSHAN CRC ELECTRONICS FACTORY	N/A
2	COPPER WIRE	QPN180	180℃	ZHUHAI SUNTEK WIRE CO.,LTD	E234867
		Polysol 180	180℃	ELEKTRISOLA(MALAYSIA) SDN.BHD.	E258243
3	CASE	WH-9100	V-0	WAH HONG INDUSTRIAL CORP	E150608
4	PIN	C5191	-----	SHENZHEN MINGSCHIN INDUSTRIAL MATERIAL CO.,LTD	N/A

RECOMMENDED REFLOW SOLDERING PROFILE

Part No. H1631CG

a. RECOMMENDED REFLOW SOLDERING PROFILE:

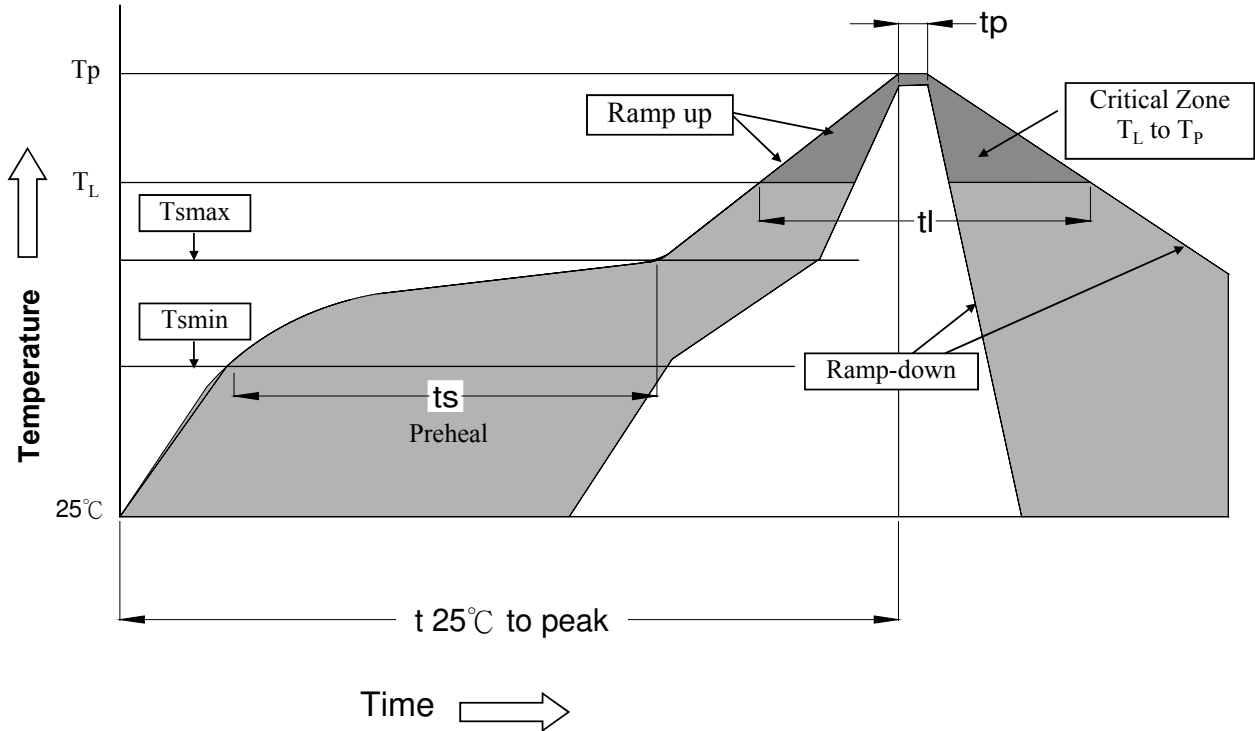

- $T_L = 217^\circ\text{C}$
- $T_p = 245^\circ\text{C}$
- $t_s = 60-180\text{s}$ $T_s \text{ max} = 200^\circ\text{C}$ $T_s \text{ min} = 150^\circ\text{C}$
- $t_L = 60-150\text{s}$ $t_p = 20-40\text{s}$ $T_{25^\circ\text{C to peak}} = 8\text{min max}$
- Ramp up rate = 3°C/s max
- Ramp down rate = 6°C/s max
- *RoHS Compliant
- *Solder Paste SAC 305 Sn 96.5/Ag 3.0/Cu 0.5
- *Silkscreen thickness: 0.15mm Min

b. MOISTURE SENSITIVE LEVEL:

- b.1. LEVEL: 1
- b.2. SHELF LIFE: UNLIMITED
- b.3. STORAGE CONDITION: $\cong 30^\circ\text{C}/85\% \text{ RH}$