

SPECIFICATIONS

PARAMETERS	VALUES	UNIT
RATED VOLTAGE (SQUARE WAVE)	6	Vpk
OPERATING VOLTAGE RANGE	3 ~ 12	Vpk
RATED CURRENT (MAX)	50	mA
COIL RESISTANCE	50± 5	OHM
MINIMUM SPL @ 10 CM	85	dBA
RESONANT FREQUENCY	2,048 ± 500	Hz
OPERATING TEMPERATURE	-20 ~ +70	°C
STORAGE TEMPERATURE	-30 ~ +80	°C
HOUSING MATERIAL	PPO	-
TERMINAL MATERIAL	Au PLATED BRASS	-
WEIGHT	7	grams

THIS DOCUMENT CONTAINS DATA PROPRIETARY TO PROJECTS UNLIMITED, INC. ANY USE OR REPRODUCTION, IN ANY FORM, WITHOUT PRIOR WRITTEN PERMISSION OF PROJECTS UNLIMITED, INC. IS PROHIBITED.
©2003, Projects Unlimited Inc.

REVISION HISTORY

LTR	DESCRIPTION	DATE	APPROVED
A	RELEASED FROM ENGINEERING	2014/07/28	B.R.

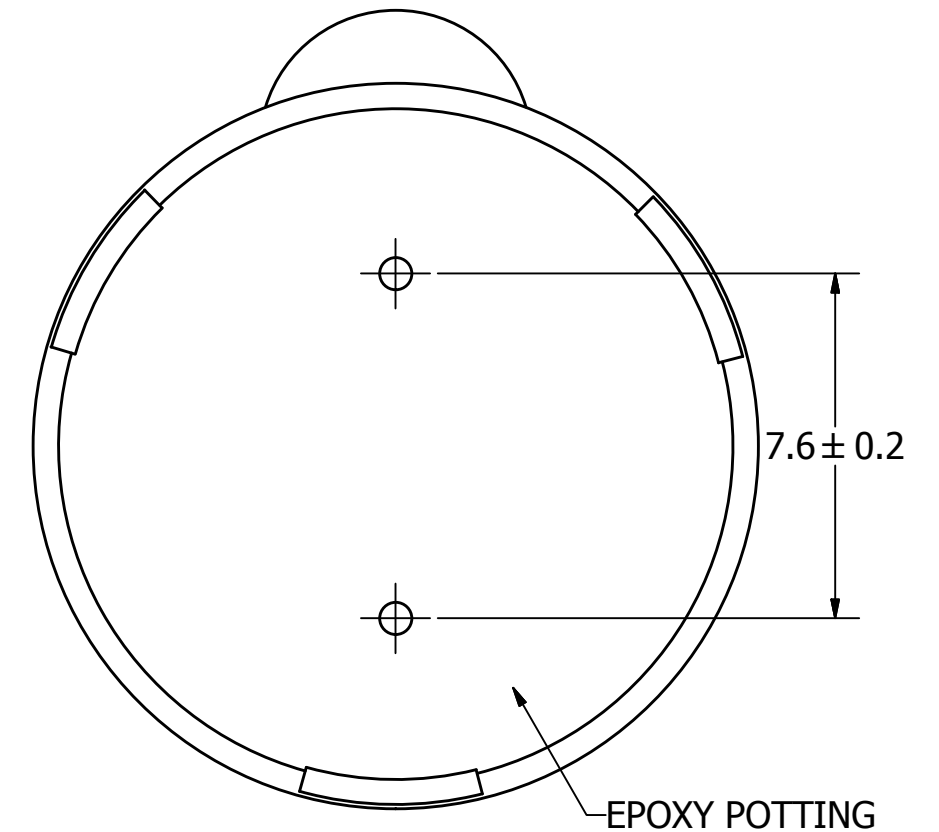
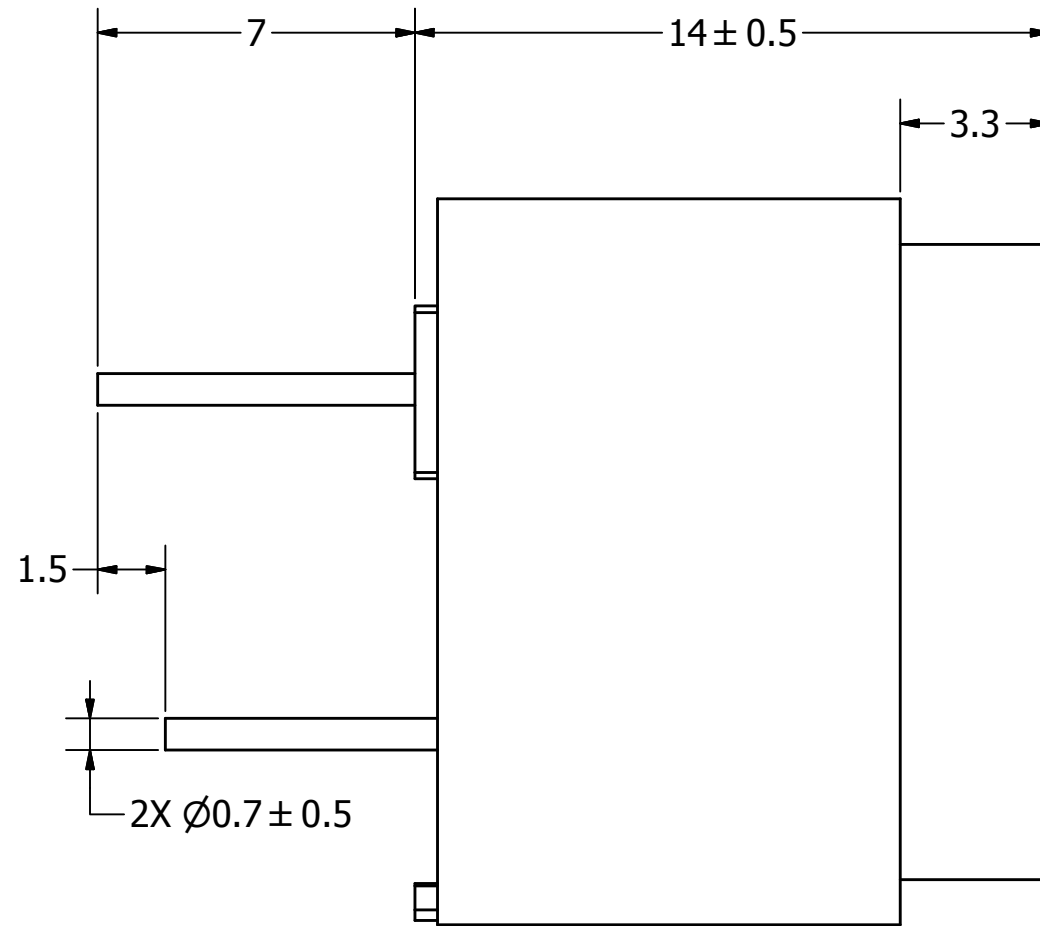
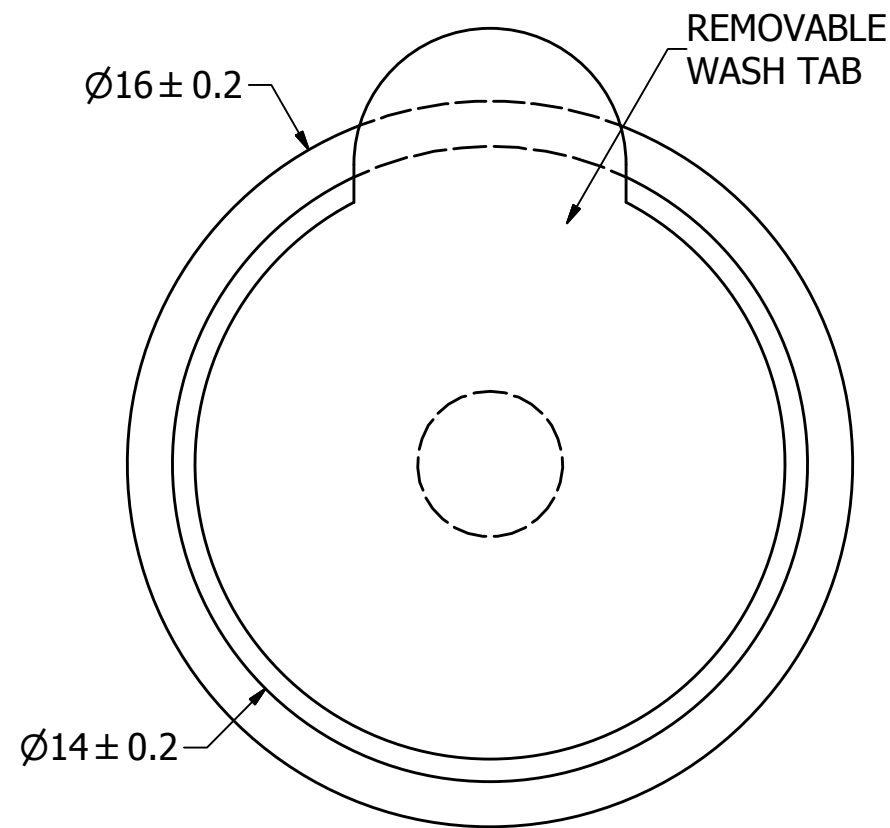

NOTES:

1. ALL DIMENSIONS ARE IN MILLIMETERS.
2. SPECIFICATIONS SUBJECT TO CHANGE OR WITHDRAWL WITHOUT NOTICE.
3. THIS PART IS RoHS 2011/65/EU COMPLIANT.

UNLESS OTHERWISE SPECIFIED:
ALL PURCHASES ARE SUBJECT TO AND INCORPORATE THE PUI AUDIO TERMS AND CONDITIONS SALE FOUND AT http://www.puiaudio.com/pdf/terms_conditions.pdf (paper copy available upon request).
DIMENSIONS ARE IN MILLIMETERS, TOLERANCES ARE ±0.5 AND ANGLES ARE ±3°.

SIZE
A3

Designed by	Date	Checked by	Date	Approved by	Date	Drawn Date
J.D.	7/28/2014	C.W.	7/28/2014	B.R.	7/28/2014	7/28/2014



AT-1620-TWT-5-R

Transducer (Electro-Mech)

Edition: -
Sheet: 1 / 1

AT-1620-TWT-5-R (2).idw