

REVISIONS				
P	LTR	DESCRIPTION	DATE	APP'D
C2	REVISED PER	ECR-15-014064	05MAR2016	NK NL

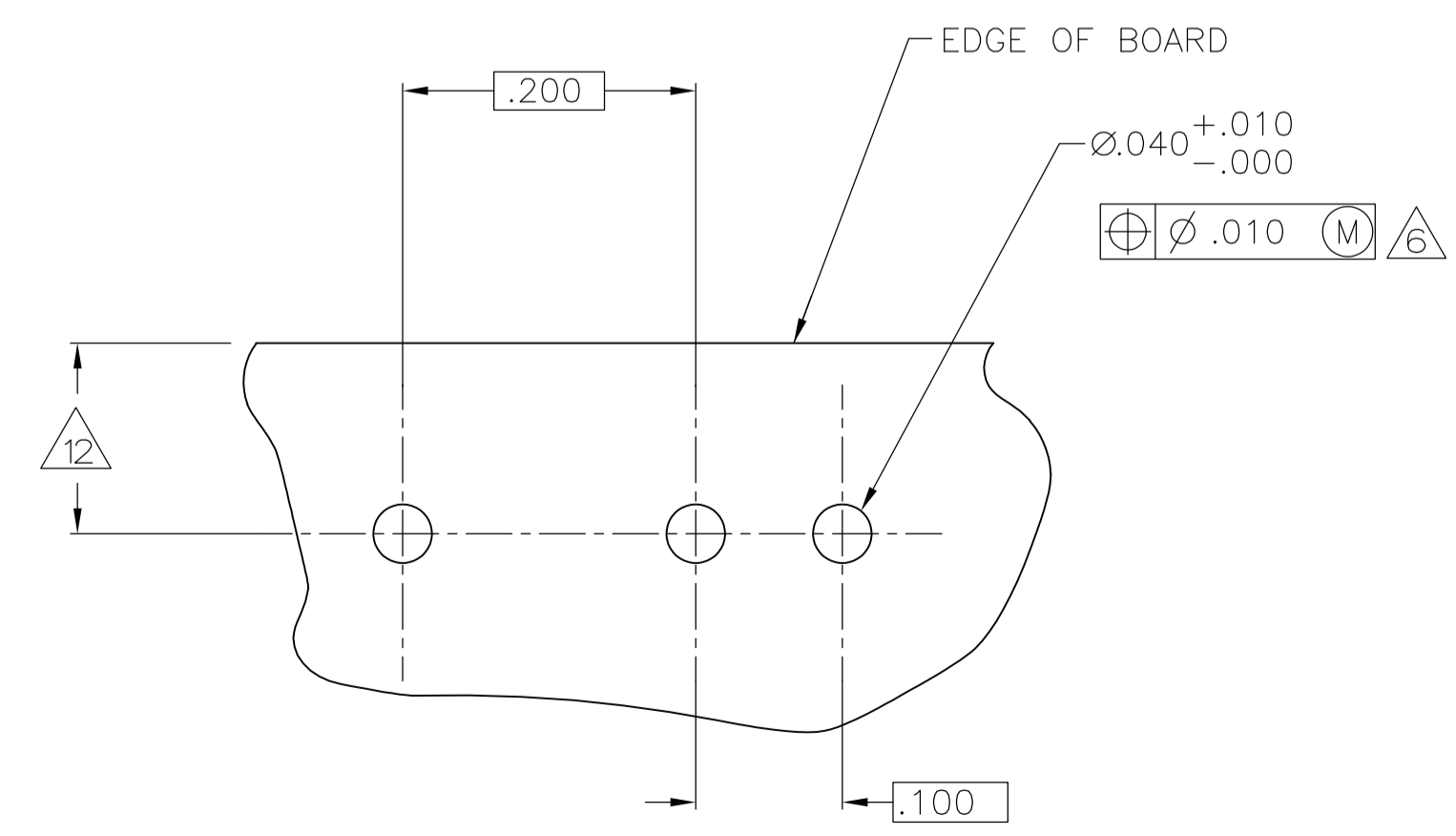
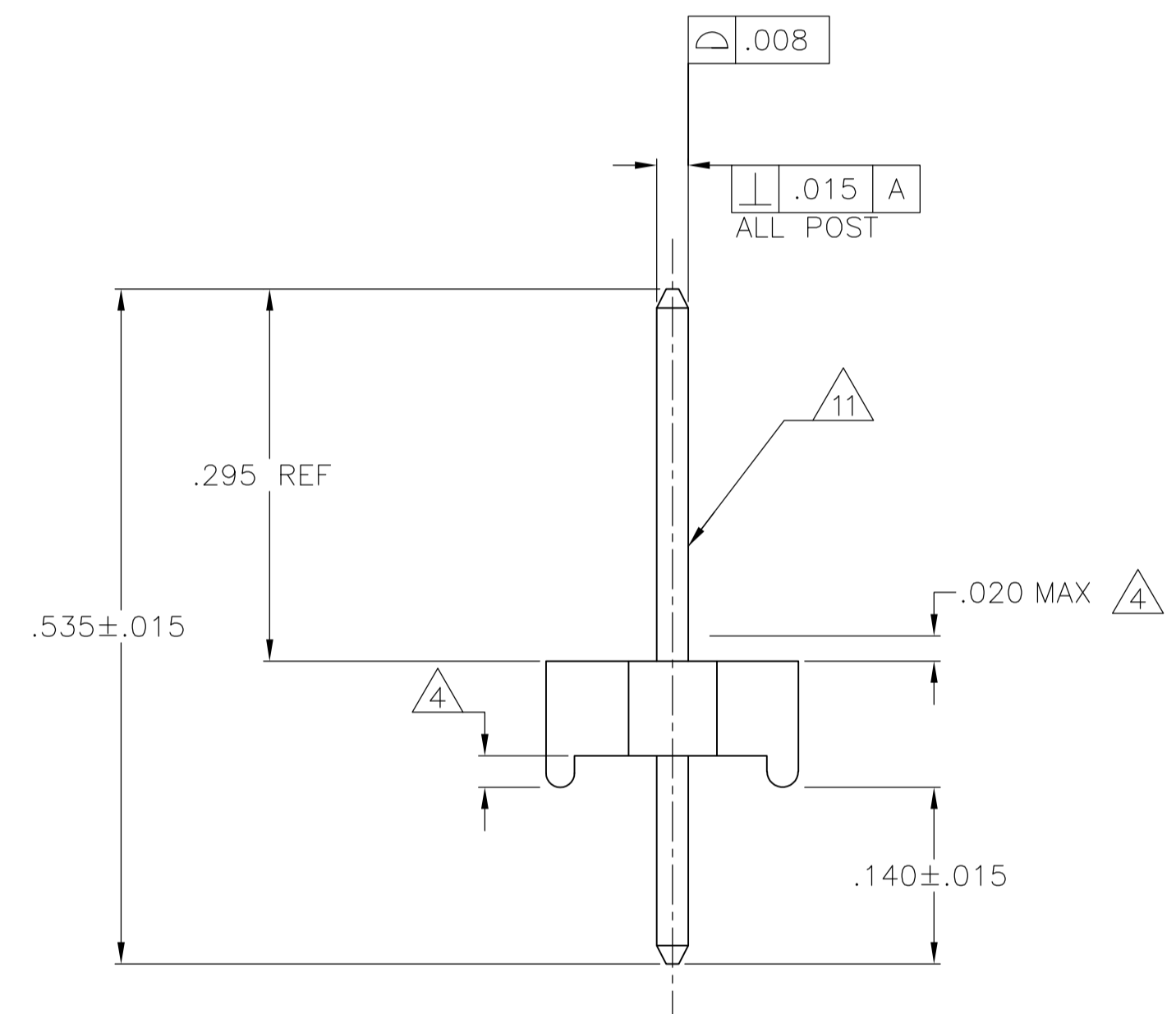
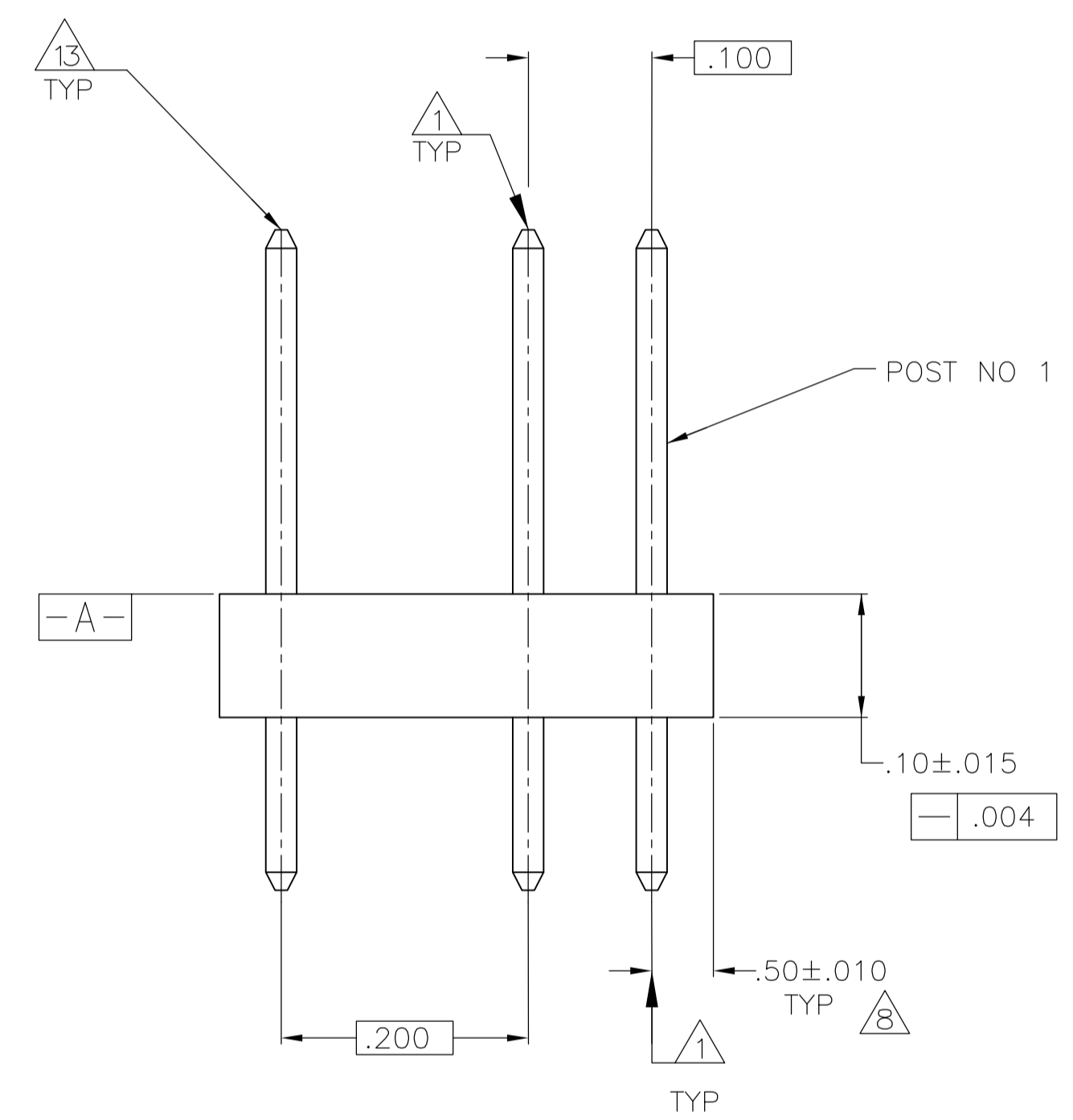
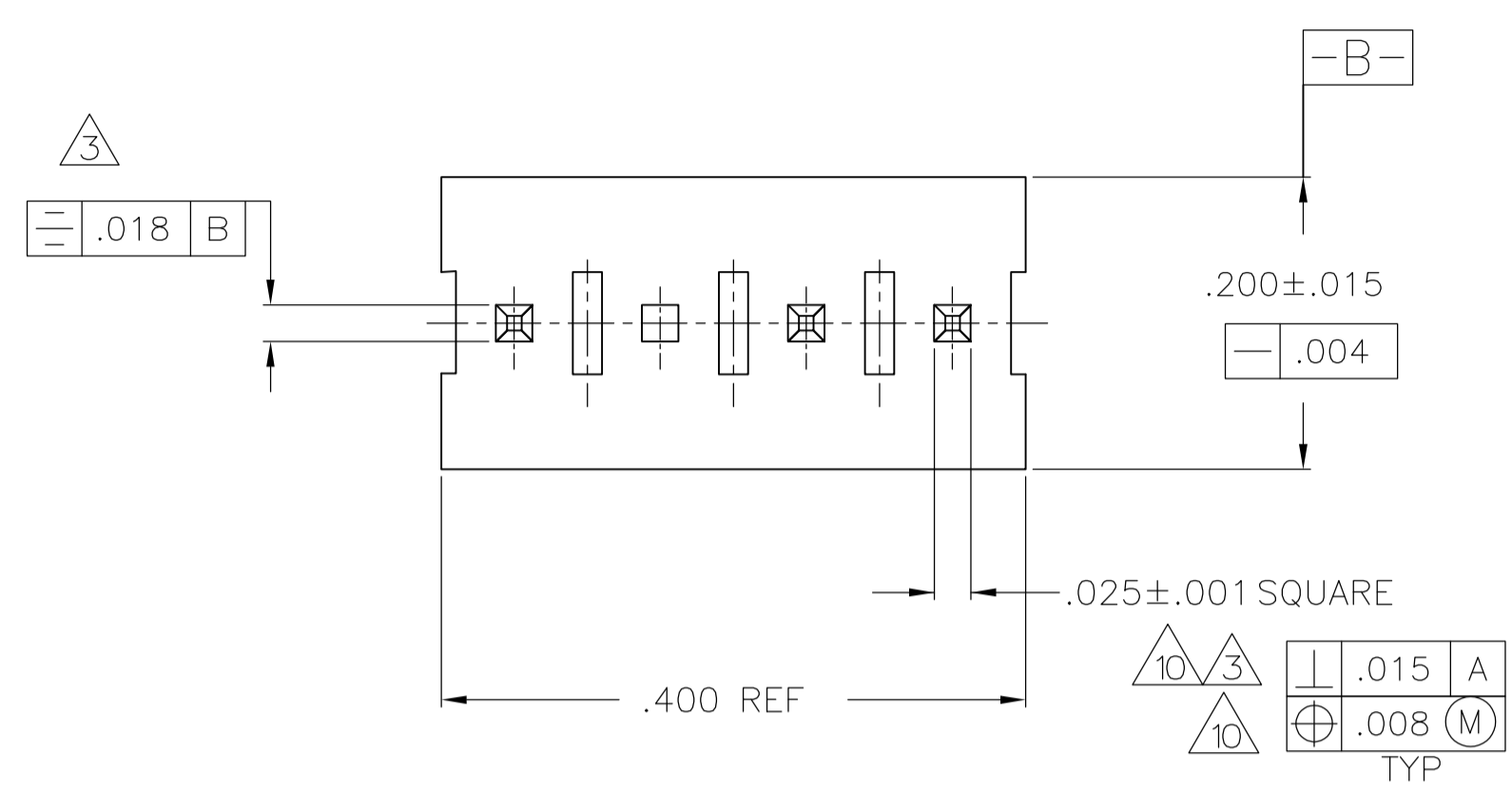

- 1 POST TO WITHSTAND 13 NEWTONS (3LBS.) MIN. AXIAL FORCE IN BOTH DIRECTIONS SHOWN WITHOUT DISLODGING.
- 2 TOLERANCES APPLY TO SOLDER SIDE OF BOARD.
- 3 MEASURED AT SURFACE. -A-
- 4 PLASTIC FLASH PERMITTED IN THIS AREA.
- 5 PARTS COMPLY WITH AMP SOLDERABILITY SPEC. NO. 109-11-2.
- 6 ONE HOLE MAY BE UNDERSIZED ($\varnothing .035 / .032$.) FOR ASSEMBLY RETENTION DURING WAVE SOLDERING.
- 7 MATERIAL: HEADER-THERMOPLASTIC POLYESTER
94V-0(NATURAL)
POST-COPPER ALLOY (TIN)
- 8 COORDINATE DIMENSION APPLIES FROM CENTER OF ACTUAL FEATURE.
- 9 PLASTIC BURRS CAUSED BY CUT-OFF TOOLING ARE PERMITTED WITHIN THE MAXIMUM TOLERANCE ENVELOPE.
- 10 POST TO BE MEASURED WHEN STRIP IS HELD FLAT.
- 11 POST MUST WITHSTAND TWO 90° BENDS AGAINST EXTRUSION WITHOUT BREAKING.
- 12 DIMENSION SHOULD BE .120 MIN. WHEN MATING WITH A MTA-100 CONNECTOR ASSEMBLY OR A CST-100 CONNECTOR.
- 13 PIN BURR OF .005 MAX. VERTICAL AND .003 MAX. HORIZONTAL PERMITTED AT POST TIPS ON BOTH ENDS.

IN	MM	IN	MM
.032	0.81	-	-
.025	0.64	.535	13.59
.020	0.51	.400	10.16
.018	0.46	.295	7.49
.015	0.38	.200	5.08
.010	0.25	.140	3.56
.008	0.20	.120	3.05
.005	0.13	.100	2.54
.004	0.10	.063	1.60
.003	0.08	.050	1.27
.001	0.03	.040	1.02
.000	0.00	.035	0.89
IN	MM	IN	MM

CONVERSION TABLE

3	643565-1
POST NUMBER OMITTED	PART NUMBER

THIS DRAWING IS A CONTROLLED DOCUMENT.

DIMENSIONS: INCHES	TOLERANCES UNLESS OTHERWISE SPECIFIED:	DIN B LEWIS 5-15-98	APPROVED BY: R SWING 5-15-98	NAME: MTA-100 HDR ASSY, PLAIN, .025 SQUARE STRAIGHT POST, TIN PLATED 4 POSITION, OMITTED POST
0 PLC ± -	1 PLC ± -	2 PLC ± -	3 PLC ± .005	4 PLC ANGLES ± -
MATERIAL: 7	FINISH: 7	WEIGHT: -	SIZE: A1	SCALE: 8:1
CUSTOMER DRAWING		DATE: 00779	DRAWING NO: 643565	SHEET 1 OF 1